

# DUBLIN FALLON 580 PROJECT

LOCAL TRANSPORTATION  
ANALYSIS  
Dublin, CA

April 3, 2024



Inside front cover

Page Intentionally blank



# Dublin Fallon 580 Project Local Transportation Analysis (LTA) Dublin, CA

Prepared for:

Prepared by:

**Kittelson & Associates, Inc.**  
155 Grand Avenue, Suite 505  
Oakland, CA 94612  
510.839.1742

Project Manager:  
Aaron Elias  
Associate Engineer

Project Principal:  
Damian Stefanakis  
Senior Principal Planner

Project Number 29998

April 3, 2024



Page Intentionally blank

# CONTENTS

1. Introduction .....	1
Project Description .....	1
2. System Overview.....	3
Roadway Network.....	3
Transit Facilities.....	4
Bicycle & Pedestrian Facilities.....	5
3. Traffic Operations Analysis .....	8
Study Location & Data Collection .....	8
Analysis Methodologies & Level of Service Standards.....	9
Intersection Operations .....	9
Existing Conditions.....	11
Near-Term Conditions .....	12
Near-Term Plus Project Conditions .....	13
Cumulative Conditions.....	16
Cumulative Plus Project Conditions.....	20
95 <sup>th</sup> Percentile Queue .....	24
CMP Assessment .....	38
Parking Assessment.....	43
4. Discussion of Effects & Recommended Improvements.....	45
Fallon Road & Dublin Boulevard .....	45
Fallon Road & Fallon Gateway.....	46
Dublin Boulevard & Commercial Access .....	46
Dublin Boulevard & Croak Road.....	47
Fallon Road & I-580 WB Ramps.....	48
95 <sup>th</sup> Percentile Queue Reduction Recommendations.....	48

## LIST OF TABLES

Table 1: ITE Trip Generation Estimate for the Project .....	1
Table 2. Existing Transit Facilities .....	5
Table 3. General Level of Service Definitions .....	9
Table 4 Existing Operations - Weekday AM and Weekday PM Peak Hours.....	11
Table 5 Near-Term Operations - Weekday AM and Weekday PM Peak Hours .....	12
Table 6: Near-Term Operations AM Peak Hour with and without the Project .....	14
Table 7: Near-Term Operations PM Peak Hour with and without the Project.....	15
Table 8 Cumulative Operations - Weekday AM and Weekday PM Peak Hours .....	19
Table 9: Cumulative Operations AM Peak Hour with and without the Project .....	22
Table 10: Cumulative Operations PM Peak Hour with and without the Project .....	23
Table 11: AM Peak Hour 95th Percentile Queue in Feet .....	26
Table 12: PM Peak Hour 95th Percentile Queue in Feet.....	32
Table 13: Analysis of CMP Segments for Existing Conditions .....	39
Table 14: Analysis of CMP Segments for 2040 Conditions.....	40
Table 15: Municipal Code Required Vs. Site Plan Provided Residential Parking.....	43
Table 16: ITE Parking Generation Vs. Provides and Municipal Code Requirements.....	43

Page intentionally blank.



## Section 1 Introduction

# 1. INTRODUCTION

This report presents the findings of the local transportation assessment (LTA) conducted for the proposed development of the property owned by GH PacVest and known as the Dublin Fallon 580 project (Project), located east of Fallon Road and south of Central Parkway in Dublin, CA.

## Project Description

The Project is proposing to develop property that is located east of Fallon Road and south of Central Parkway in Dublin, CA. The applicant for the Project identified the proposed project as a mix of residential, industrial, and commercial uses. The identified uses include:

- 238 Multifamily Residential Dwelling Units
- 2,888,400 Square Feet of Advanced Manufacturing
- 314 Hotel Rooms
- 100,000 Square Feet of Retail
- 100,000 Square Feet of Office

The resulting trip generation per the 11<sup>th</sup> Edition of the Institute of Transportation Engineer's (ITE) Trip Generation manual for the daily, AM peak hour, and the PM peak hour is shown in Table 1.

**Table 1: ITE Trip Generation Estimate for the Project**

Description	Size	Units	ITE	Daily	AM Peak Hour			PM Peak Hour		
					In	Out	Total	In	Out	Total
Multi-Family	238	du	220	1,604	23	73	96	77	45	122
Advanced Manufacturing	2,888.4	ksf	140	13,720	1,493	472	1,965	663	1,475	2,138
Hotel	314	Rooms	310	2,509	81	64	145	95	91	186
Retail	100	ksf	820	3,701	52	32	84	163	177	340
Office	100	ksf	710	1,084	134	18	152	24	120	144
Total				22,618	1,783	659	2,442	1,022	1,908	2,930

# Section 2

## System Overview



## 2. SYSTEM OVERVIEW

The following section describes the existing conditions of the study area, including roadway, transit, bicycle, and pedestrian networks.

### Roadway Network

#### Freeways

**Interstate 580 (I-580)** is a generally east-west freeway that runs south of the project site. I-580 connects the San Francisco Bay Area to the west and the City of Livermore to the east. The posted speed limit in the vicinity of the project is 65 miles per hour (mph). Express lanes are present in both directions and are in effect Monday through Friday from 5:00 a.m. to 8:00 p.m.

#### Arterials/Collectors/Local Roadways

**Dublin Boulevard** is a six-lane divided east-west roadway that extends west of the project site. Dublin Boulevard is classified in the City's General Plan<sup>1</sup> as an arterial between its western limits and Tassajara Road and classified as a collector between Tassajara Road and Fallon Road (as well as the proposed extension to North Canyons Parkway). On-street parking is not permitted along this roadway and the posted speed limit is 45 mph in the vicinity of the project. Dublin Boulevard is proposed to be extended connecting from its current terminus at Fallon Road to North Canyons Parkway in Livermore.

**Central Parkway** is a two-lane divided east-west roadway that extends west from Croak Road west of the project to Sterling. The roadway generally runs through residential land uses and provides access to Cottonwood Creek K-8 School near the project. Central Parkway is classified as an arterial between Tassajara Road and Fallon Road and as a collector for its remaining extent. On-street parking is permitted east of Sunset View Drive near the project and in other segments abutting residential land uses. The posted speed limit is 25 mph in vicinity of the project. Central Parkway would be extended with the Francis Ranch (East Ranch) project with the proposed Project widening to the ultimate configuration.

**Croak Road** is a north-south roadway that is currently not accessible to the public near the project site. Croak Road connects to Fallon Road near I-580, Central Parkway at its eastern terminus, and Terracina Drive. The roadway is classified as a local residential roadway between Central Parkway and Positano Parkway. Once the Dublin Boulevard extension is constructed, Croak Road will connect Dublin Boulevard and Central Parkway. In the interim, Francis Ranch (East Ranch) will construct part of Croak Road as a two lane roadway near Central Parkway.

**Fallon Road/El Charro Road** is a north-south divided roadway that widens from four lanes south of Central Parkway to six lanes to the north; south of I-580, Fallon Road becomes El Charro Road within the City of Pleasanton. Fallon Road is classified as an arterial roadway near the project site. The roadway primarily serves residential land uses within the City of Dublin, with some retail located near I-580. On-

---

<sup>1</sup> The City of Dublin General Plan. *Chapter 5: Land Use and Circulation – Circulation and Scenic Highways Element*. Amended 2022. <https://www.dublin.ca.gov/DocumentCenter/View/7799/Chapter-5-May-2020?bidId=>

street parking is not permitted along this roadway. The posted speed limit is 45 mph in the vicinity of the project.

**Stoneridge Drive/Jack London Boulevard** is an east-west roadway located south of I-580; the roadway is Stoneridge Drive within the City of Pleasanton and Jack London Boulevard within the City of Livermore. Stoneridge Drive/Jack London Boulevard is classified as an arterial between Foothill Road and its eastern limits. On-street parking is not permitted along this roadway. Class II bicycle lanes are present along much of its length. The posted speed limit is 40 mph in the City of Pleasanton (Stoneridge Drive) and increases to 45 mph in the City of Livermore (Jack London Boulevard). Stoneridge Drive is a 4 to 6-lane roadway; Jack London Boulevard varies from 2 to 6 lanes.

**Tassajara Road** is a major north-south roadway in Dublin that connects to Fallon Road/Camino Tassajara to the north and the City of San Ramon and Contra Costa County to the south. Tassajara Road is classified as an arterial roadway within the City of Dublin; south of I-580 within the City of Pleasanton, the roadway becomes Santa Rita Road. The roadway varies from two lanes to five lanes and is divided along its southern portion, between Stoneridge Drive and Dublin Ranch Drive. On-street parking is not permitted along this roadway. The posted speed limit is 35 mph within the study area. Class II bicycle lanes are present, except for on the overpass over I-580.

**Hacienda Drive** is a north-south roadway that provides access to office, residential, and retail land uses such as Hacienda Crossings and Persimmon Place. Hacienda Drive is classified as an arterial and ranges from 3 lanes to 6 lanes. On-street parking is not permitted. The posted speed limit is 35 mph within the study area.

**North Canyons Parkway** is an east-west arterial roadway that will connect to the planned Dublin Boulevard extension at its present western terminus at Doolan Road. The roadway merges with Portola Avenue at Collier Canyon Road. It is a four-lane, divided road with a posted speed limit of 40 mph near the study area. On-street parking is generally prohibited, and a bicycle lane is present on both sides of the road. North Canyons Parkway provides access to commercial and office land uses east of the project site, including several hotels and a Costco Wholesale warehouse.

**Airway Boulevard** is a north-south roadway in Livermore that provides access to I-580 and the Livermore Municipal Airport and connects to North Canyons Parkway at its northern terminus. It is classified as an arterial roadway and is a divided six-lane road north of Kitty Hawk Rd/I-580 EB off-ramp. The posted speed limit is 45 mph. Class II bicycle lanes are present, except for on the overpass over I-580.

## Transit Facilities

The Project area is served by Tri-Valley Wheels, which provides fixed-route bus service operated by the Livermore Amador Valley Transit Authority (LAVTA) to Dublin, Livermore, Pleasanton, and neighboring communities. Wheels also offers a Dial-A-Ride Paratransit service to eligible patrons in Dublin, available wherever fixed-route service is operating. Three routes directly serve the area surrounding the Project – Route 2, Route 30R (Rapid), and Route 501 (School Route). Currently, Route 30R follows Dublin Boulevard to Fallon Road, where it detours to I-580 before connecting to North Canyons Parkway. With the

extension of Dublin Boulevard, this route is likely to use the extension and directly serve the non-residential portions of the Project which have access via Dublin Boulevard.

The area is also served by Bay Area Rapid Transit (BART), with the nearest station being Dublin/Pleasanton which is located approximately four miles west of the site.

Table 2 provides details about the bus service that serves the Project area, and

**Table 2. Existing Transit Facilities**

Route	Route Type	Major Destinations	Day	Times	Frequency
2	Fixed Route	E. Dublin/Pleasanton BART, Dublin Ranch, Emerald Glen Park, Fallon Middle School	Weekdays	One AM trip, one PM trip	2 per day
30R	Rapid Route	Lawrence Livermore National Laboratory, East Ave., Livermore Transit Center, Portola Park, and Ride, Las Positas College, N. Canyons, Dublin Blvd, E. Dublin BART, Dublin Civic Center, W. Dublin BART	Weekdays	5:00 AM to 11:00 PM	Every 30 minutes
			Weekends	5:00 AM to 11:00 PM	Hourly
501 (A, B, C)	School Route	Positano, Fallon Road, Silvera Ranch, Tassajara Road, Central Pwky., Dublin HS	Weekdays	One AM trip, one PM trip for each route	2 per day

Source: [wheelsbus.com](http://wheelsbus.com)

## Bicycle & Pedestrian Facilities

Dublin’s existing bikeway system consists of the following bikeway types, as defined in the City of Dublin’s *Bicycle and Pedestrian Plan (2023)*.

- **Class I Multi-Use Paths** provide a separate facility designed for the exclusive use of bicycles, pedestrians, and other non-motorized uses with minimal vehicle crossflows.
  - *Class IA Paths* exist along a separate alignment.
  - *Class IB Sidepaths* double as sidewalks along the side of the roadway.
- **Class II Bicycle Lanes** are on-street bikeways that provide a dedicated space for exclusive or semi-exclusive bicycle use.
  - *Class IIA Lanes* are conventional one-way striped bike lanes.
  - *Class IIB Lanes* are upgraded bike lanes with striped buffers or green conflict markings.
- **Class III Bicycle Routes** do not provide a dedicated space for bicycles but instead, bikes share the lane with motorists and signs, or pavement markings indicate the bike route.
  - *Class IIIA Routes* are signage-only routes.
  - *Class IIIB Routes* have wide curb lanes or shoulders.
  - *Class IIIC Routes* are routes with standard shared-lane markings (“sharrows”).
- **Class IV Separated Bicycle Lanes** are bicycle lanes that provide vertical separation (e.g. grade separation, flexible posts, planters, on-street parking, etc.) from motorists on roadways.

Existing bicycle facilities in the vicinity of the project include:

- Fallon Road has Class II facilities north of Dublin Boulevard, as well as Class IB sidepaths on the west side, north of Gleason Drive.
- Dublin Boulevard generally has Class II facilities west of Fallon Road.
- Central Parkway generally has Class II facilities east and west of Fallon Road. However, there is a Class III facility on Central Parkway eastbound between Fallon Road and Sunset View Drive. Central Parkway east of Fallon Road also has Class IB sidepaths.
- Stoneridge Drive/Jack London Boulevard has Class II facilities east and west of El Charro Road.
- Airway Boulevard has Class II bicycle facilities south of N. Canyons Parkway.
- N. Canyons Parkway has Class II facilities east of Airway Boulevard

# Section 3

## Traffic Operations Analysis

## 3. TRAFFIC OPERATIONS ANALYSIS

### Study Location & Data Collection

Based on consultation with relevant agency staff, seventeen (17) existing intersections near the study location were identified as study locations. An additional five (5) intersections are included to account for two future intersections (identified with a "\*" below) and three project driveways (identified with an "\*\*" below). This results in a total of twenty-two (22) intersections which include:

1. Hacienda Drive & Dublin Boulevard
2. Tassajara Road & Central Parkway
3. Tassajara Road & Dublin Boulevard
4. Tassajara Road & I-580 WB Ramps
5. Santa Rita Rd & I-580 EB Ramps/Pimlico Dr
6. Tassajara Road & Fallon Road
7. Fallon Road & Positano Parkway
8. Fallon Road & Central Parkway
9. Fallon Road & Dublin Boulevard
10. Fallon Road & Fallon Gateway
11. Fallon Road & I-580 WB Ramps
12. El Charro Road & I-580 EB Ramps
13. El Charro Road & Jack London Boulevard
14. Central Parkway & Sunset View Drive
15. Central Parkway & Panorama Drive/Pino Grande Road
16. Airway Boulevard & N. Canyons Parkway
17. Airway Boulevard & I-580 WB Ramps
18. Dublin Boulevard & Commercial Access Driveway\*\*
19. Pandora Way & Residential Project Access Driveway (Parcel 7)\*\*
20. Croak Road & Central Parkway\*
21. Croak Road & Project Access (Parcel 8)\*\*
22. Croak Road & Dublin Boulevard\*

Data at the 17 intersections that exist today were collected on January 18, 2024 which was a typical midweek day with good weather when schools were in session. Appendix A contains the raw count data from this data collection effort. In addition to intersection counts, signal timing plans were requested for each study intersection that is signalized from the jurisdiction that owns the signal which included the city of Dublin, city of Pleasanton, and Caltrans.

## Analysis Methodologies & Level of Service Standards

Traffic operations were evaluated for the twenty-two study intersections using level of service (LOS) which describes the operating conditions experienced by users of a facility. LOS is a qualitative measure of the effect of a few factors, including speed and travel time, traffic interruptions, freedom to maneuver, driving comfort, and convenience. Levels of service are designated "A" through "F" from best to worst, which cover the entire range of traffic operations that might occur. LOS "A" through "E" generally represent traffic volumes at less than roadway capacity, while LOS "F" represents locations over capacity and/or experiencing significant delays. These conditions are generally described in Table 3.

**Table 3. General Level of Service Definitions**

LOS	Description of Traffic Conditions	Average Delay per Vehicle (Seconds)	
		Signalized Intersection	Unsignalized Intersection
A	LOS A represents free-flow travel with excellent levels of comfort and convenience and the freedom to maneuver.	≤10.0	≤10.0
B	LOS B has stable operating conditions, but the presence of other road users causes a noticeable, though slight, reduction in comfort, convenience, and maneuvering freedom.	>10.0 and ≤20.0	>10.0 and ≤15.0
C	LOS C has stable operating conditions, but the operation of individual users is substantially affected by the interaction with others in the traffic stream.	>20.0 and ≤35.0	>15.0 and ≤25.0
D	LOS D represents high-density, but stable flow. Users experience severe restriction in speed and freedom to maneuver, with poor levels of comfort and convenience.	>35.0 and ≤55.0	>25.0 and ≤35.0
E	LOS E represents operating conditions at or near capacity. Speeds are reduced to a low but relatively uniform value. Freedom to maneuver is difficult with users experiencing frustration and poor comfort and convenience. Unstable operation is frequent, and minor disturbances in traffic flow can cause breakdown conditions.	>55.0 and ≤80.0	>35.0 and ≤50.0
F	LOS F is used to define forced or breakdown conditions. This condition exists wherever the volume of traffic exceeds the capacity of the roadway. Long queues can form behind these bottleneck points with queued traffic traveling in a stop-and-go fashion.	>80.0	>50.0

Source: *Highway Capacity Manual*

## Intersection Operations

To ascertain the existing traffic conditions, traffic operations were evaluated at the twenty-two study intersections. Level of service (LOS) was determined for each intersection for the following scenarios:

- Existing Conditions (2024 conditions without the project)
- Near-Term No Project (Estimate of conditions in 2028 without the Project)
- Near-Term Plus Project (Conditions in 2028 plus just the residential portion of the Project)
- Cumulative (2040) No Project (Based on the City of Dublin travel demand model)
- Cumulative (2040) Plus Project (2040 conditions plus full buildout of the Project)

Intersection operations were evaluated using the *Highway Capacity Manual (HCM) 7<sup>th</sup> Edition* methodologies as implemented by the Vistro software program. The HCM 7<sup>th</sup> Edition procedure calculates a weighted average stop delay in seconds per vehicle at an intersection and assigns a level of service designation based on the delay. Based on the City of Dublin's Transportation Impact Analysis Guidelines (July 2021), the following criteria were used to determine whether the Project resulted in a significant effect on the local transportation system.

#### Signalized Intersections:

- ▶ At a study, signalized intersection which is located outside the Downtown Dublin Specific Plan area, the project would cause the motor vehicle LOS to degrade to worse than LOS D (i.e., LOS E or F);
- ▶ At a study, signalized intersection which is located within the Downtown Dublin Specific Plan area, the project would cause the motor vehicle (LOS to degrade to worse than LOS E (i.e., LOS F);
- ▶ At a study, signalized intersection which is located outside the Downtown Dublin Specific Plan area where the motor vehicle level of service is LOS E, the project would cause the total intersection average vehicle delay to increase by six (6) seconds or more; or
- ▶ At a study, signalized intersection for all areas where the level of service is LOS F, the project would cause: (a) the overall volume-to-capacity (V/C) ratio to increase 0.03 or more; or (b) the critical movement V/C ratio to increase by 0.05 or more.
- ▶ For intersections located along routes of regional significance, the Tri-Valley Transportation Plan and Action Plan identifies LOS E or better as the standard for the Multimodal Transportation Service Objective (MTSO) related to intersection LOS. Routes of regional significance in the study area include:
  - Dublin Boulevard
  - Tassajara Road
  - Fallon Road
  - North Canyons Parkway
  - Jack London Boulevard

#### Unsignalized Intersections

- ▶ At a study, unsignalized intersection which is located outside the Downtown Dublin Specific Plan area, the project would cause the motor vehicle LOS to degrade to worse than LOS D (i.e., LOS E or F) and after project completion satisfy the California Manual on Uniform Traffic Control Devices (MUTCD) peak hour traffic signal warrant;
- ▶ At a study, unsignalized intersection which is located within the Downtown Dublin Specific Plan area, the project would cause the motor vehicle LOS to degrade to worse than LOS E (i.e., LOS F) and after project completion satisfy the California Manual on Uniform Traffic Control Devices (MUTCD) peak hour traffic signal warrant; or
- ▶ At a study, unsignalized intersection where the motor vehicle level of service is operating below the LOS threshold, the project would add ten (10) or more vehicles to the critical movement and after project completion satisfy the California Manual on Uniform Traffic Control Devices (MUTCD) peak hour traffic signal warrant.



## Existing Conditions

Based on the existing intersection count data, intersection geometry (Appendix B), and signal timing sheets, the existing traffic operations at the study intersections for the AM and PM peak hours were calculated and reported in Table 4. Appendix C contains the detailed output sheets from the analysis software documenting these findings. As shown, all intersections operate at LOS D or better.

**Table 4 Existing Operations - Weekday AM and Weekday PM Peak Hours**

#	Intersection	Existing AM			Existing PM		
		V/C	Delay	LOS	V/C	Delay	LOS
1	Hacienda Drive & Dublin Boulevard	0.35	43.5	D	0.40	38.7	D
2	Tassajara Road & Central Parkway	0.58	28.1	C	0.48	27.9	C
3	Tassajara Road & Dublin Boulevard	0.48	31.8	C	0.67	37.0	D
4	Tassajara Road & I-580 WB Ramps	0.59	13.2	B	0.63	11.1	B
5	Santa Rita Rd & I-580 EB Ramps/Pimlico Dr	0.73	31.4	C	0.81	33.2	C
6	Tassajara Road & Fallon Road	0.64	21.9	C	0.39	15.2	B
7	Fallon Road & Positano Parkway	0.78	22.1	C	0.50	9.3	A
8	Fallon Road & Central Parkway	0.57	31.9	C	0.36	20.9	C
9	Fallon Road & Dublin Boulevard	0.53	20.1	C	0.48	21.4	C
10	Fallon Road & Fallon Gateway	0.53	13.3	B	0.59	13.0	B
11	Fallon Road & I-580 WB Ramps	0.77	8.2	A	0.54	17.1	B
12	El Charro Road & I-580 EB Ramps	0.39	6.8	A	0.54	6.9	A
13	El Charro Road & Jack London Boulevard	0.29	10.5	B	0.69	11.3	B
14	Central Parkway & Sunset View Drive	0.76	31.0	C	0.26	11.1	B
15	Central Parkway & Panorama Drive/Pino Grande Road	0.36	11.0	B	0.15	8.0	A
16	Airway Boulevard & N. Canyons Parkway	0.27	13.7	B	0.46	16.4	B
17	Airway Boulevard & I-580 WB Ramps	0.22	9.8	A	0.21	10.1	B
18	Dublin Boulevard & Commercial Access Driveway	N/A			N/A		
19	Pandora Way & Residential Project Access Driveway (Parcel 7)	N/A			N/A		
20	Croak Road & Central Parkway	N/A			N/A		
21	Croak Road & Project Access (Parcel 8)	N/A			N/A		
22	Croak Road & Dublin Boulevard	N/A			N/A		

Source: Kittelson & Associates, 2024 based on Highway Capacity Manual, 7<sup>th</sup> Edition Methodologies

Notes: Delay in seconds; Grey highlighted cells indicate operations below the LOS standard; N/A indicated intersection does not exist under the analysis scenario.

## Near-Term Conditions

Near-term conditions represent background traffic growth to the year 2028. These volumes were derived based on an interpolation of the city of Dublin’s travel demand model outputs for the years 2020 and 2040. The transportation network and signal timing were kept the same as existing conditions. The resulting intersection operations are shown in Table 5. All study intersections were found to operate at LOS D or better. Near-term lane configurations and traffic volumes are provided in Appendix D. Appendix E provides the detailed output sheets for near-term conditions.

**Table 5 Near-Term Operations - Weekday AM and Weekday PM Peak Hours**

#	Intersection	Near-Term AM			Near-Term PM		
		V/C	Delay	LOS	V/C	Delay	LOS
1	Hacienda Drive & Dublin Boulevard	0.39	41.8	D	0.47	39.7	D
2	Tassajara Road & Central Parkway	0.59	28.3	C	0.55	32.0	C
3	Tassajara Road & Dublin Boulevard	0.60	39.5	D	0.84	51.5	D
4	Tassajara Road & I-580 WB Ramps	0.63	13.4	B	0.67	11.5	B
5	Santa Rita Rd & I-580 EB Ramps/Pimlico Dr	0.75	32.5	C	0.85	35.0	D
6	Tassajara Road & Fallon Road	0.67	22.8	C	0.43	15.6	B
7	Fallon Road & Positano Parkway	0.86	31.3	C	0.56	10.7	B
8	Fallon Road & Central Parkway	0.57	32.1	C	0.40	21.2	C
9	Fallon Road & Dublin Boulevard	0.55	23.2	C	0.68	34.2	C
10	Fallon Road & Fallon Gateway	0.53	13.1	B	0.63	13.4	B
11	Fallon Road & I-580 WB Ramps	0.75	8.7	A	0.59	24.5	C
12	El Charro Road & I-580 EB Ramps	0.43	6.8	A	0.60	7.2	A
13	El Charro Road & Jack London Boulevard	0.42	13.8	B	0.72	13.9	B
14	Central Parkway & Sunset View Drive	0.76	31.6	C	0.26	11.2	B
15	Central Parkway & Panorama Drive/Pino Grande Road	0.36	11.0	B	0.15	8.0	A
16	Airway Boulevard & N. Canyons Parkway	0.44	17.8	B	0.62	25.1	C
17	Airway Boulevard & I-580 WB Ramps	0.25	13.5	B	0.25	9.0	A
18	Dublin Boulevard & Commercial Access Driveway	N/A			N/A		
19	Pandora Way & Residential Project Access Driveway (Parcel 7)	N/A			N/A		
20	Croak Road & Central Parkway	N/A			N/A		
21	Croak Road & Project Access (Parcel 8)	N/A			N/A		
22	Croak Road & Dublin Boulevard	N/A			N/A		

Source: Kittelson & Associates, 2024 based on Highway Capacity Manual, 7<sup>th</sup> Edition Methodologies

Notes: Delay in seconds; Grey highlighted cells indicate operations below the LOS standard; N/A indicated intersection does not exist under the analysis scenario.

## Near-Term Plus Project Conditions

Near-term plus project conditions were developed to determine the effect that the residential component of the project will have on the transportation system under opening year conditions. The analysis assumes the transportation network would remain the same as today with the two residential parcels being accessed by Central Parkway. This analysis analyzed two project driveway intersections (#19 & #21) and assumes the intersection of Croak Road and Central Parkway would be constructed but would only be used by Project traffic. The lane configuration and volumes are provided in Appendix F while Appendix G has the detailed operational output sheets. Appendix L shows the change in traffic volumes between the near term no project and plus project scenarios.

Two project driveways would be needed in the near term with project scenario to provide access to the two residential parcels with one accessed off Pandora Way and the second accessed from Croak Road. The lane configuration and traffic control assumed for these two intersections is shown below. As shown, the access for parcel 7 was assumed to be all-way stop control. This was assumed since the project is proposing a connection where Pino Grande Road curves to meet Pandora Way. All-way stop presents a conservative analysis of intersection operations for this access location and improved safety given the roadway curvature. Parcel 8 is proposed to be side street stop controlled.

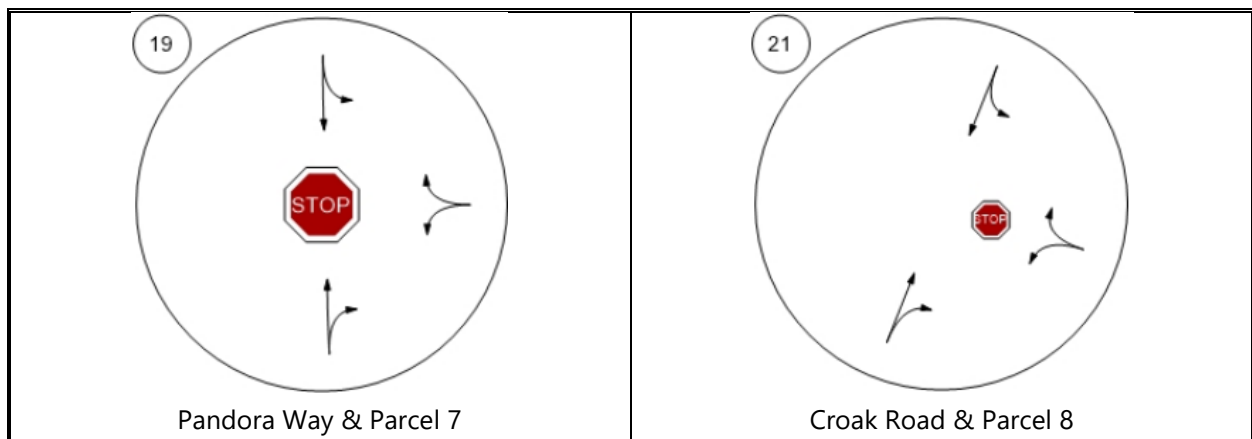

A summary of the intersection operations compared to the no project conditions are shown in Table 6 and Table 7 for the AM and PM peak hours, respectively. As shown, the residential component of the Project has limited effect on intersection operations and all intersections operate at or better than their respective LOS standard.

**Table 6: Near-Term Operations AM Peak Hour with and without the Project**

#	Intersection	Near-Term AM			Near-Term AM PP		
		V/C	Delay	LOS	V/C	Delay	LOS
1	Hacienda Drive & Dublin Boulevard	0.39	41.8	D	0.39	41.9	D
2	Tassajara Road & Central Parkway	0.59	28.3	C	0.59	28.4	C
3	Tassajara Road & Dublin Boulevard	0.60	39.5	D	0.60	40.0	D
4	Tassajara Road & I-580 WB Ramps	0.63	13.4	B	0.63	13.4	B
5	Santa Rita Rd & I-580 EB Ramps/Pimlico Dr	0.75	32.5	C	0.75	32.5	C
6	Tassajara Road & Fallon Road	0.67	22.8	C	0.67	22.8	C
7	Fallon Road & Positano Parkway	0.86	31.3	C	0.86	31.7	C
8	Fallon Road & Central Parkway	0.57	32.1	C	0.61	34.1	C
9	Fallon Road & Dublin Boulevard	0.55	23.2	C	0.57	23.4	C
10	Fallon Road & Fallon Gateway	0.53	13.1	B	0.54	13.5	B
11	Fallon Road & I-580 WB Ramps	0.75	8.7	A	0.78	9.0	A
12	El Charro Road & I-580 EB Ramps	0.43	6.8	A	0.44	6.8	A
13	El Charro Road & Jack London Boulevard	0.42	13.8	B	0.42	13.8	B
14	Central Parkway & Sunset View Drive	0.76	31.6	C	0.86	42.5	D
15	Central Parkway & Panorama Drive/Pino Grande Road	0.36	11.0	B	0.47	13.3	B
16	Airway Boulevard & N. Canyons Parkway	0.44	17.8	B	0.44	17.9	B
17	Airway Boulevard & I-580 WB Ramps	0.25	13.5	B	0.25	13.4	B
18	Dublin Boulevard & Commercial Access Driveway	N/A			N/A		
19	Pandora Way & Residential Project Access Driveway (Parcel 7)	N/A			0.06	7.1	A
20	Croak Road & Central Parkway	N/A			0.06	7.9	A
21	Croak Road & Project Access (Parcel 8)	N/A			0.04	8.5	A
22	Croak Road & Dublin Boulevard	N/A			N/A		

Source: Kittelson & Associates, 2024 based on Highway Capacity Manual, 7<sup>th</sup> Edition Methodologies

Notes: Delay in seconds; Grey highlighted cells indicate operations below the LOS standard; N/A indicated intersection does not exist under the analysis scenario.

**Table 7: Near-Term Operations PM Peak Hour with and without the Project**

#	Intersection	Near-Term PM			Near-Term PM PP		
		V/C	Delay	LOS	V/C	Delay	LOS
1	Hacienda Drive & Dublin Boulevard	0.47	39.7	D	0.47	40.2	D
2	Tassajara Road & Central Parkway	0.55	32.0	C	0.55	32.0	C
3	Tassajara Road & Dublin Boulevard	0.84	51.5	D	0.85	53.0	D
4	Tassajara Road & I-580 WB Ramps	0.67	11.5	B	0.68	11.7	B
5	Santa Rita Rd & I-580 EB Ramps/Pimlico Dr	0.85	35.0	D	0.85	35.2	D
6	Tassajara Road & Fallon Road	0.43	15.6	B	0.43	15.6	B
7	Fallon Road & Positano Parkway	0.56	10.7	B	0.56	10.7	B
8	Fallon Road & Central Parkway	0.40	21.2	C	0.41	21.5	C
9	Fallon Road & Dublin Boulevard	0.68	34.2	C	0.68	34.2	C
10	Fallon Road & Fallon Gateway	0.63	13.4	B	0.63	13.3	B
11	Fallon Road & I-580 WB Ramps	0.59	24.5	C	0.59	26.5	C
12	El Charro Road & I-580 EB Ramps	0.60	7.2	A	0.61	7.2	A
13	El Charro Road & Jack London Boulevard	0.72	13.9	B	0.72	13.9	B
14	Central Parkway & Sunset View Drive	0.26	11.2	B	0.31	11.2	B
15	Central Parkway & Panorama Drive/Pino Grande Road	0.15	8.0	A	0.18	8.3	A
16	Airway Boulevard & N. Canyons Parkway	0.62	25.1	C	0.62	25.1	C
17	Airway Boulevard & I-580 WB Ramps	0.25	9.0	A	0.25	9.0	A
18	Dublin Boulevard & Commercial Access Driveway	N/A			N/A		
19	Pandora Way & Residential Project Access Driveway (Parcel 7)	N/A			0.06	7.1	A
20	Croak Road & Central Parkway	N/A			0.04	7.1	A
21	Croak Road & Project Access (Parcel 8)	N/A			0.01	8.4	A
22	Croak Road & Dublin Boulevard	N/A			N/A		

Source: Kittelson & Associates, 2024 based on Highway Capacity Manual, 7<sup>th</sup> Edition Methodologies

Notes: Delay in seconds; Grey highlighted cells indicate operations below the LOS standard; N/A indicated intersection does not exist under the analysis scenario.

## Cumulative Conditions

Cumulative conditions assesses whether the Project will have significant effects to the transportation network in the year 2040 which is the current horizon year for the city of Dublin travel demand model. Cumulative no project conditions analyze the operations of the study intersections in 2040 based on changes to the transportation network and travel demand growth from land use changes between today and 2040. Cumulative lane configurations and traffic volumes are provided in Appendix H. Appendix I provides the detailed output sheets for Cumulative conditions.

Key changes to the transportation network affecting the study intersections are related to Dublin Boulevard which is proposed to be extended from Fallon Road east to North Canyons Parkway. This extension will also result in the extension of Croak Road to connect Central Parkway with the Dublin Boulevard extension. Finally, Fallon Road is assumed to be widened to four through lanes in each direction between the I-580 WB Off-Ramp and Central Parkway consistent with the plan line study. The effects on lane configuration are detailed below comparing existing and cumulative conditions.

- **Fallon Road and Dublin Boulevard (#9)** – Based on discussions with the city of Dublin, the current 65% design plans for the Dublin Boulevard extension, and the Fallon Road plan line, this intersection will be reconfigured as shown below.

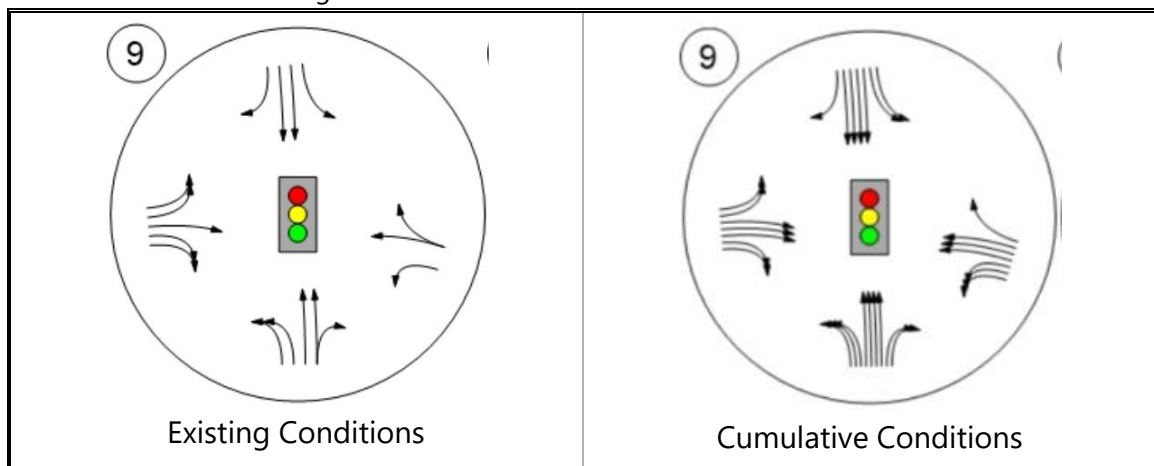

- **Fallon Road and Fallon Gateway (#10)** – Based on discussions with the city of Dublin and considering the Fallon Road plan line study, this intersection will be reconfigured as shown below.

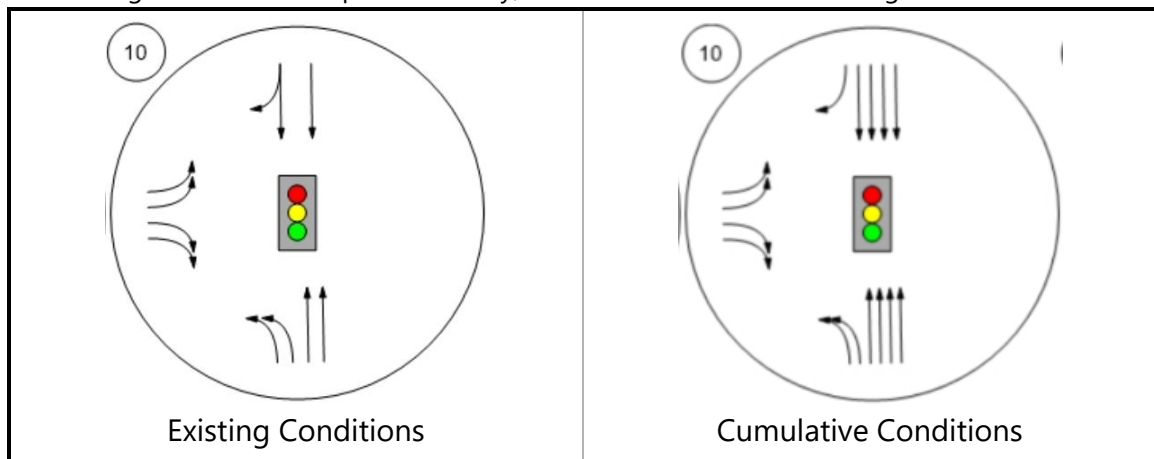

- ▶ **Airway Boulevard & N. Canyons Parkway (#16)** – As part of the Dublin Boulevard extension project, this intersection will be reconfigured as shown below.

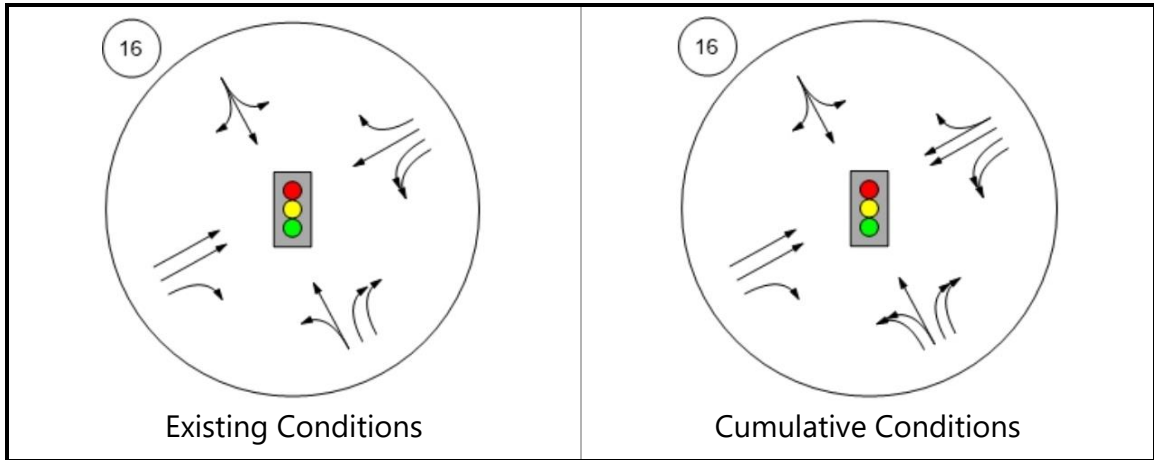

- ▶ **Croak Road & Central Parkway (#20)** – As part of planned roadway changes in the future, this intersection will provide access to new housing development off Central Parkway and be part of the Croak Road connection between Central Parkway and Dublin Boulevard. The intersection is assumed to be configured as shown below.

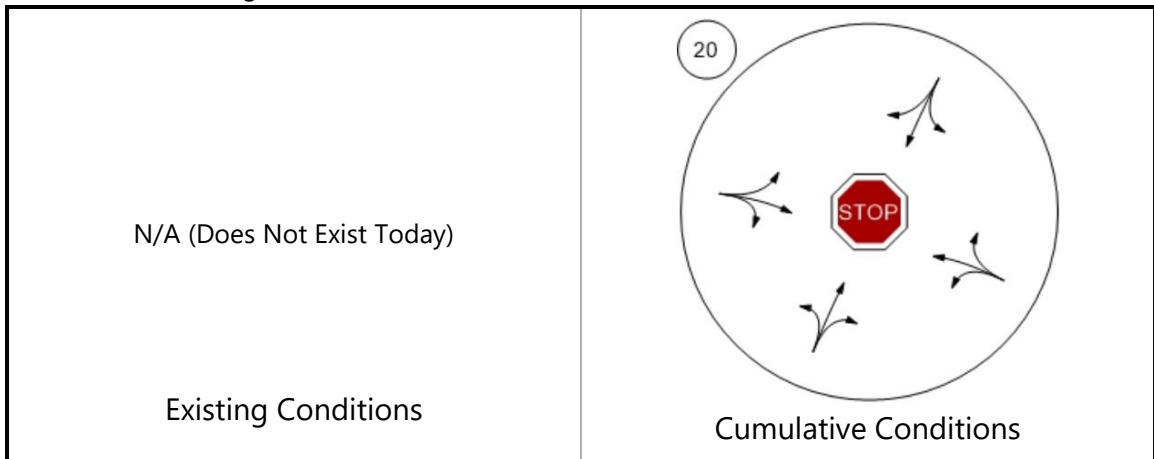

- ▶ **Croak Road & Dublin Boulevard (#22)** – As part of planned roadway changes in the future, this intersection will connect Central Parkway to Dublin Boulevard via Croak Road. The intersection is assumed to be configured as shown below.

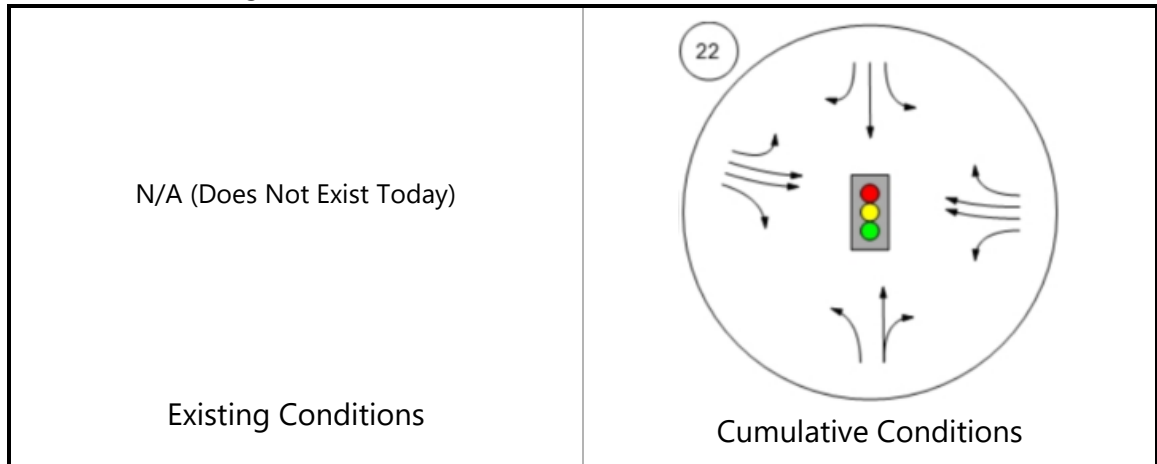

The operations of the study intersections under cumulative conditions are summarized in Table 8. Four intersections are anticipated to operate below their respective LOS standard. These intersections include:

- ▶ Tassajara Road and Dublin Boulevard is projected to operate at LOS F in the AM and PM peak hours which is below the LOS E standard for intersections on routes of regional significance.
- ▶ Fallon Road & Positano Parkway is projected to operate at LOS F in the AM peak hour which is below the LOS E standard for intersections on routes of regional significance.
- ▶ Airway Boulevard & N. Canyons Parkway is projected to operate at LOS F in the PM peak hour which is below the LOS E standard for intersections on routes of regional significance.
- ▶ Airway Boulevard & I-580 WB Ramp is projected to operate at LOS E in the AM peak hour which is below the LOS D standard for signalized intersections not on routes of regional significance.



**Table 8 Cumulative Operations - Weekday AM and Weekday PM Peak Hours**

#	Intersection	Cumulative AM			Cumulative PM		
		V/C	Delay	LOS	V/C	Delay	LOS
1	Hacienda Drive & Dublin Boulevard	0.57	64.8	E	0.67	46.0	D
2	Tassajara Road & Central Parkway	0.64	29.3	C	0.78	48.7	D
3	Tassajara Road & Dublin Boulevard	1.19	178.7	F	1.35	144.3	F
4	Tassajara Road & I-580 WB Ramps	0.76	15.2	B	0.81	15.5	B
5	Santa Rita Rd & I-580 EB Ramps/Pimlico Dr	0.81	36.4	D	0.97	48.3	D
6	Tassajara Road & Fallon Road	0.73	26.7	C	0.52	18.0	B
7	Fallon Road & Positano Parkway	1.09	94.2	F	0.71	16.6	B
8	Fallon Road & Central Parkway	0.59	32.8	C	0.61	25.8	C
9	Fallon Road & Dublin Boulevard	0.70	43.7	D	0.74	48.1	D
10	Fallon Road & Fallon Gateway	0.33	9.6	A	0.48	10.7	B
11	Fallon Road & I-580 WB Ramps	0.71	13.5	B	0.75	61.5	E
12	El Charro Road & I-580 EB Ramps	0.69	7.5	A	0.79	8.5	A
13	El Charro Road & Jack London Boulevard	0.75	41.7	D	0.78	31.1	C
14	Central Parkway & Sunset View Drive	0.79	33.4	C	0.26	11.4	B
15	Central Parkway & Panorama Drive/Pino Grande Road	0.36	11.0	B	0.15	8.1	A
16	Airway Boulevard & N. Canyons Parkway	0.69	23.8	C	1.19	145.0	F
17	Airway Boulevard & I-580 WB Ramps	0.47	64.2	E	0.36	7.9	A
18	Dublin Boulevard & Commercial Access Driveway	N/A			N/A		
19	Pandora Way & Residential Project Access Driveway (Parcel 7)	N/A			N/A		
20	Croak Road & Central Parkway	0.50	11.6	B	0.59	13.5	B
21	Croak Road & Project Access (Parcel 8)	N/A			N/A		
22	Croak Road & Dublin Boulevard	0.62	21.1	C	0.64	18.8	B

Source: Kittelson & Associates, 2024 based on Highway Capacity Manual, 7<sup>th</sup> Edition Methodologies

Notes: Delay in seconds; Grey highlighted cells indicate operations below the LOS standard; N/A indicated intersection does not exist under the analysis scenario.

## Cumulative Plus Project Conditions

The cumulative plus project analysis estimates the effect of the full Project on conditions in 2040. The Project was coded into the travel demand model due to its size and potential to change non-project travel patterns in the vicinity. Lane configurations were similar to the no project cumulative conditions but there were three additional intersections added including one for each residential partial (also modeled for the near-term plus project conditions) and an access point for the industrial development that was added between Fallon Road and Croak Road along the Dublin Boulevard extension.

There are no site plans for any component of the Project except the residential parcels. Kittelson has assumed that the office, retail, and hotel components of the Project will be accessed via the Fallon Road & Fallon Gateway intersections. No access is assumed at this intersection for the approximately 2.9 million square feet of advanced manufacturing space. These land uses are all assumed to have access to either the Dublin Boulevard extension or Croak Road. Lane configurations assumed in this analysis for the access points into the non-residential portions of the Project are shown below. The residential access points would remain the same as shown in the near-term plus project conditions.

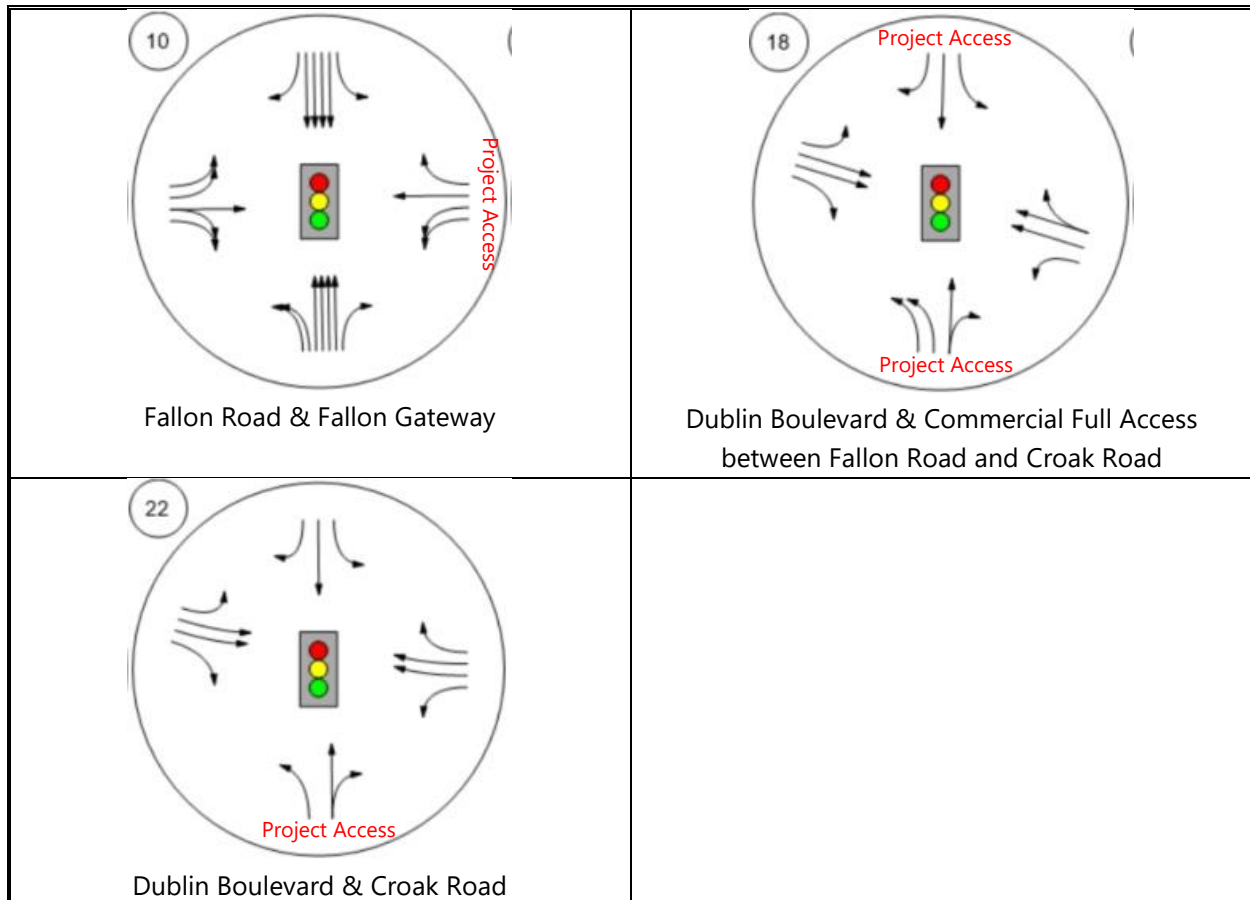

The lane configuration and volumes are provided in Appendix J while Appendix K has the detailed operational output sheets. Appendix M shows the change in traffic volumes between the near term no project and plus project scenarios. A summary of the intersection operations compared to the no project

conditions are shown in Table 9 and Table 10 for the AM and PM peak hours, respectively. Key findings from the cumulative plus project evaluation include:

- ▶ **Tassajara Road & Dublin Boulevard (#3)** is projected to operate at LOS F with and without the Project under cumulative conditions. However, the Project's effect on traffic volumes in the area results in enough of a change that the Project improves intersection operations at this location in both the AM and PM peak hour. No recommendations for improvement are proposed at this location since the operations are improving.
- ▶ **Fallon Road & Positano Parkway (#7)** is projected to fail in the AM peak hour for the cumulative no project scenario. The redistribution of vehicles as a result of the Project resulted in the intersection improving to LOS E for the AM peak hour which meets the LOS E standard for intersections on routes of regional significance. No recommendations for improvement are proposed at this location since the Project results in an improvement to operations at the intersection where it will meet the LOS standard.
- ▶ **Fallon Road & Dublin Boulevard (#9)** is projected to deteriorate from LOS D to LOS F in the PM peak hour as a result of the Project. Recommendations for improvement at this location are detailed in the next section of the report.
- ▶ **Fallon Road & I-580 WB Ramps (#11)** is projected to deteriorate to LOS F in the AM and PM peak hours as a result of the Project. While there are plans to improve the interchange of Fallon Road and I-580, this analysis has assumed there are no changes to present a conservative case. Recommendations for improvement at this location are detailed in the next section of the report.
- ▶ **Airway Boulevard & N. Canyons Parkway (#16)** is projected to fail in the PM peak hour for the cumulative no project scenario. The redistribution of vehicles as a result of the Project resulted in reduced delay at the intersection. No recommendations for improvement are proposed at this location since the Project results in an improvement to operations at the intersection.
- ▶ **Airway Boulevard & I-580 WB Ramp (#17)** is projected to operate at LOS E in the AM peak hour under cumulative no project conditions. The redistribution of vehicles as a result of the Project will improve the intersection to LOS D. No recommendations for improvement are proposed at this location since the Project results in an improvement to operations.

**Table 9: Cumulative Operations AM Peak Hour with and without the Project**

#	Intersection	Cumulative AM			Cumulative AM PP		
		V/C	Delay	LOS	V/C	Delay	LOS
1	Hacienda Drive & Dublin Boulevard	0.57	64.8	E	0.56	56.7	E
2	Tassajara Road & Central Parkway	0.64	29.3	C	0.64	29.1	C
3	Tassajara Road & Dublin Boulevard	1.19	178.7	F	1.20	166.8	F
4	Tassajara Road & I-580 WB Ramps	0.76	15.2	B	0.78	15.9	B
5	Santa Rita Rd & I-580 EB Ramps/Pimlico Dr	0.81	36.4	D	0.81	36.3	D
6	Tassajara Road & Fallon Road	0.73	26.7	C	0.70	26.4	C
7	Fallon Road & Positano Parkway	1.09	94.2	F	1.05	75.0	E
8	Fallon Road & Central Parkway	0.59	32.8	C	0.66	42.9	D
9	Fallon Road & Dublin Boulevard	0.70	43.7	D	0.80	45.0	D
10	Fallon Road & Fallon Gateway	0.33	9.6	A	0.43	15.8	B
11	Fallon Road & I-580 WB Ramps	0.71	13.5	B	1.06	179.5	F
12	El Charro Road & I-580 EB Ramps	0.69	7.5	A	0.84	10.1	B
13	El Charro Road & Jack London Boulevard	0.75	41.7	D	0.87	76.7	E
14	Central Parkway & Sunset View Drive	0.79	33.4	C	0.79	34.4	C
15	Central Parkway & Panorama Drive/Pino Grande Road	0.36	11.0	B	0.38	12.0	B
16	Airway Boulevard & N. Canyons Parkway	0.69	23.8	C	0.73	25.1	C
17	Airway Boulevard & I-580 WB Ramps	0.47	64.2	E	0.48	42.7	D
18	Dublin Boulevard & Commercial Access Driveway	N/A			0.65	33.8	C
19	Pandora Way & Residential Project Access Driveway (Parcel 7)	N/A			0.06	7.1	A
20	Croak Road & Central Parkway	0.50	11.6	B	0.51	11.8	B
21	Croak Road & Project Access (Parcel 8)	N/A			0.06	10.4	B
22	Croak Road & Dublin Boulevard	0.62	21.1	C	0.65	36.0	D

Source: Kittelson & Associates, 2024 based on Highway Capacity Manual, 7<sup>th</sup> Edition Methodologies

Notes: Delay in seconds; Grey highlighted cells indicate operations below the LOS standard; N/A indicated intersection does not exist under the analysis scenario.

**Table 10: Cumulative Operations PM Peak Hour with and without the Project**

#	Intersection	Cumulative PM			Cumulative PM PP		
		V/C	Delay	LOS	V/C	Delay	LOS
1	Hacienda Drive & Dublin Boulevard	0.67	46.0	D	0.68	44.5	D
2	Tassajara Road & Central Parkway	0.78	48.7	D	0.76	45.1	D
3	Tassajara Road & Dublin Boulevard	1.35	144.3	F	1.33	133.1	F
4	Tassajara Road & I-580 WB Ramps	0.81	15.5	B	0.82	16.7	B
5	Santa Rita Rd & I-580 EB Ramps/Pimlico Dr	0.97	48.3	D	0.97	45.6	D
6	Tassajara Road & Fallon Road	0.52	18.0	B	0.49	17.1	B
7	Fallon Road & Positano Parkway	0.71	16.6	B	0.71	15.1	B
8	Fallon Road & Central Parkway	0.61	25.8	C	0.62	26.3	C
9	Fallon Road & Dublin Boulevard	0.74	48.1	D	0.89	83.4	F
10	Fallon Road & Fallon Gateway	0.48	10.7	B	0.73	42.4	D
11	Fallon Road & I-580 WB Ramps	0.75	61.5	E	1.20	113.4	F
12	El Charro Road & I-580 EB Ramps	0.79	8.5	A	0.83	8.5	A
13	El Charro Road & Jack London Boulevard	0.78	31.1	C	0.80	38.6	D
14	Central Parkway & Sunset View Drive	0.26	11.4	B	0.29	11.8	B
15	Central Parkway & Panorama Drive/Pino Grande Road	0.15	8.1	A	0.15	8.2	A
16	Airway Boulevard & N. Canyons Parkway	1.19	145.0	F	1.15	142.7	F
17	Airway Boulevard & I-580 WB Ramps	0.36	7.9	A	0.38	9.2	A
18	Dublin Boulevard & Commercial Access Driveway	N/A			0.95	54.9	D
19	Pandora Way & Residential Project Access Driveway (Parcel 7)	N/A			0.06	7.1	A
20	Croak Road & Central Parkway	0.59	13.5	B	0.61	14.0	B
21	Croak Road & Project Access (Parcel 8)	N/A			0.02	10.4	B
22	Croak Road & Dublin Boulevard	0.64	18.8	B	0.85	44.6	D

Source: Kittelson & Associates, 2024 based on Highway Capacity Manual, 7<sup>th</sup> Edition Methodologies

Notes: Delay in seconds; Grey highlighted cells indicate operations below the LOS standard; N/A indicated intersection does not exist under the analysis scenario.

## 95<sup>th</sup> Percentile Queue

In addition to an assessment of intersection operations, 95<sup>th</sup> percentile queues were assessed for each of the study intersections during the AM and PM peak hours. Comparisons between the estimated queue storage and estimated queue length are shown in Table 11 and Table 12. Queues shown in these tables are reported in feet and rounded up to the nearest 5 foot increment. Grey highlighted cells indicate where 95<sup>th</sup> percentile queues are estimated to exceed the available queue storage. Potential recommendations to address queues are provided when the Project causes the queue to exceed the available storage, or the Project increases the queue for a movement already exceeding the storage by 25 feet (one vehicle) or more. The following intersections and movements were found to meet these criteria:

- ▶ Hacienda Drive & Dublin Boulevard (#1)
  - The Project causes the NBL turn lane to exceed the available storage by 5 feet under cumulative conditions in the PM peak hour.
- ▶ Tassajara Road & Central Parkway (#2)
  - The Project causes the EBR turn lane, which already exceeds the available storage under cumulative conditions in the PM peak hour, to increase from 275 feet to 355 feet.
- ▶ Tassajara Road & Dublin Boulevard (#3)
  - The Project causes the NBR turn lane, which is already exceeding the available storage, to increase from approximately 1,810 feet to 2,170 feet under cumulative plus project conditions in the AM peak hour.
  - The Project causes the NBR turn lane, which is already exceeding the available storage, to increase from approximately 1,200 feet to 1,260 feet under near-term plus project conditions in the PM peak hour.
- ▶ Santa Rita Rd & I-580 EB Ramps/Pimlico Dr (#5)
  - The Project causes the SBL turn lane, which is already exceeding the available storage, to increase from approximately 440 feet to 500 feet under cumulative plus project conditions in the PM peak hour.
- ▶ Fallon Road & Positano Parkway (#7)
  - The Project causes the NBR turn lane to exceed the available storage by 10 feet under cumulative conditions in the PM peak hour.
- ▶ Fallon Road & Central Parkway (#8)
  - The Project causes the WBL turn lane to increase from 200 feet to 255 feet (approximately two vehicles) under near-term plus project conditions in the AM peak hour. This causes the WBL turn movement to exceed the available 200 foot storage.
- ▶ Fallon Road & Dublin Boulevard (#9)
  - The Project causes the southbound right turn lane, which is already exceeding the available storage under cumulative no project conditions in the AM peak hour and PM peak hours, to increase from 355 feet to 530 feet in the AM and 195 feet to 350 feet in the PM.
  - The Project causes the SBL turn lane, which already exceeds the available storage under cumulative PM conditions, to extend from 210 feet to 390 feet.
- ▶ Fallon Road & I-580 WB Ramps (#11)
  - The Project causes the SBR turn lane to exceed the available storage by more than 1,500 feet in the PM peak hour under cumulative conditions.

- ▶ Airway Boulevard & N. Canyons Parkway (#16)
  - The Project causes the westbound left turn, which is already exceeding the available storage under cumulative conditions in the AM peak hour, to increase from 280 feet to 310 feet.

**Table 11: AM Peak Hour 95th Percentile Queue in Feet**

AM Peak Hour 95 <sup>th</sup> Percentile Queues in Feet (Rounded Up to Nearest 5 Feet)									
Intersection		NBL	NBR	SBL	SBR	EBL	EBR	WBL	WBR
Intersection 1: Hacienda Drive & Dublin Boulevard	Storage	250	380	300	220	300	250	275	-
	Existing	130	120	15	110	75	60	175	-
	Near-Term	145	120	15	125	75	75	240	-
	Near-Term Plus Project	145	120	15	125	75	75	250	-
	Cumulative	195	120	15	170	75	105	740	-
	Cumulative Plus Project	205	125	15	115	75	95	625	-
Intersection 2: Tassajara Road & Central Parkway	Storage	325	325	300	215	225	225	300	-
	Existing	50	55	25	70	150	95	170	-
	Near-Term	55	60	25	75	150	95	170	-
	Near-Term Plus Project	55	60	25	75	150	95	170	-
	Cumulative	60	75	35	100	150	95	170	-
	Cumulative Plus Project	50	70	30	80	150	95	170	-
Intersection 3: Tassajara Road & Dublin Boulevard	Storage	380	250	295	290	265	330	395	-
	Existing	90	270	25	55	55	60	190	-
	Near-Term	115	465	35	65	65	60	220	-
	Near-Term Plus Project	120	470	35	70	65	60	225	-
	Cumulative	165	1810	60	85	70	60	260	-
	Cumulative Plus Project	185	2170	65	95	70	60	230	-
Intersection 4: Tassajara Road & I-580 WB Ramps	Storage	-	-	-	-	-	-	1325	1325
	Existing	-	-	-	-	-	-	205	110
	Near-Term	-	-	-	-	-	-	205	110
	Near-Term Plus Project	-	-	-	-	-	-	205	110



AM Peak Hour 95 <sup>th</sup> Percentile Queues in Feet (Rounded Up to Nearest 5 Feet)									
Intersection		NBL	NBR	SBL	SBR	EBL	EBR	WBL	WBR
	<b>Cumulative</b>	-	-	-	-	-	-	205	115
	<b>Cumulative Plus Project</b>	-	-	-	-	-	-	205	115
Intersection 5: Santa Rita Rd & I-580 EB Ramps/Pimlico Dr	<b>Storage</b>	-	-	425	-	625	-	200	250
	<b>Existing</b>	-	-	240	-	410	-	105	185
	<b>Near-Term</b>	-	-	240	-	440	-	105	185
	<b>Near-Term Plus Project</b>	-	-	240	-	440	-	105	185
	<b>Cumulative</b>	-	-	240	-	555	-	105	190
	<b>Cumulative Plus Project</b>	-	-	240	-	550	-	105	195
Intersection 6: Tassajara Road & Fallon Road	<b>Storage</b>	175	175	175	225	475	175	100	100
	<b>Existing</b>	180	5	5	175	85	175	20	10
	<b>Near-Term</b>	200	10	5	210	100	190	20	10
	<b>Near-Term Plus Project</b>	200	10	5	210	100	190	20	10
	<b>Cumulative</b>	260	10	5	320	160	240	25	20
	<b>Cumulative Plus Project</b>	250	10	5	275	150	230	30	15
Intersection 7: Fallon Road & Positano Parkway	<b>Storage</b>	-	225	335	-	-	-	360	450
	<b>Existing</b>	-	150	290	-	-	-	175	345
	<b>Near-Term</b>	-	155	315	-	-	-	185	615
	<b>Near-Term Plus Project</b>	-	155	315	-	-	-	185	625
	<b>Cumulative</b>	-	170	375	-	-	-	200	2075
	<b>Cumulative Plus Project</b>	-	160	395	-	-	-	215	1765
Intersection 8: Fallon Road & Central Parkway	<b>Storage</b>	300	255	295	245	350	230	250	250
	<b>Existing</b>	35	160	105	60	35	50	200	85
	<b>Near-Term</b>	40	160	105	65	40	50	200	85

AM Peak Hour 95 <sup>th</sup> Percentile Queues in Feet (Rounded Up to Nearest 5 Feet)									
Intersection		NBL	NBR	SBL	SBR	EBL	EBR	WBL	WBR
	<b>Near-Term Plus Project</b>	40	185	110	70	40	55	255	95
	<b>Cumulative</b>	50	160	110	75	45	105	205	85
	<b>Cumulative Plus Project</b>	50	170	110	75	45	130	210	90
Intersection 9: Fallon Road & Dublin Boulevard	<b>Storage</b>	430	-	140	225	400	400	-	-
	<b>Existing</b>	190	80	0	100	115	145	0	0
	<b>Near-Term</b>	200	115	5	135	115	140	15	45
	<b>Near-Term Plus Project</b>	210	115	5	150	115	140	15	45
	<b>Cumulative</b>	195	135	15	355	135	90	10	295
	<b>Cumulative Plus Project</b>	175	625	105	530	135	105	10	315
Intersection 10: Fallon Road & Fallon Gateway	<b>Storage</b>	275	-	-	-	210	210	-	-
	<b>Existing</b>	60	-	-	-	10	25	-	-
	<b>Near-Term</b>	60	-	-	-	10	25	-	-
	<b>Near-Term Plus Project</b>	60	-	-	-	10	25	-	-
	<b>Cumulative</b>	55	-	-	-	10	20	-	-
	<b>Cumulative Plus Project</b>	75	-	90	-	10	40	30	25
Intersection 11: Fallon Road & I-580 WB Ramps	<b>Storage</b>	-	-	-	225	-	-	1550	1550
	<b>Existing</b>	-	-	-	75	-	-	35	40
	<b>Near-Term</b>	-	-	-	85	-	-	40	50
	<b>Near-Term Plus Project</b>	-	-	-	100	-	-	45	50
	<b>Cumulative</b>	-	-	-	145	-	-	65	95
	<b>Cumulative Plus Project</b>	-	-	-	180	-	-	85	130
Intersection 12: El Charro Road & I-580 EB Ramps	<b>Storage</b>	-	-	-	-	605	605	-	-

AM Peak Hour 95 <sup>th</sup> Percentile Queues in Feet (Rounded Up to Nearest 5 Feet)									
Intersection		NBL	NBR	SBL	SBR	EBL	EBR	WBL	WBR
	<b>Existing</b>	-	-	-	-	25	20	-	-
	<b>Near-Term</b>	-	-	-	-	25	25	-	-
	<b>Near-Term Plus Project</b>	-	-	-	-	25	25	-	-
	<b>Cumulative</b>	-	-	-	-	25	35	-	-
	<b>Cumulative Plus Project</b>	-	-	-	-	100	40	-	-
Intersection 13: El Charro Road & Jack London Boulevard	<b>Storage</b>	125	-	650	450	450	325	400	775
	<b>Existing</b>	5	-	30	15	25	5	10	25
	<b>Near-Term</b>	15	-	35	35	35	5	25	45
	<b>Near-Term Plus Project</b>	20	-	35	35	35	5	25	50
	<b>Cumulative</b>	100	-	75	185	95	25	125	210
	<b>Cumulative Plus Project</b>	120	-	75	200	110	25	120	230
Intersection 14: Central Parkway & Sunset View Drive	<b>Storage</b>	250	250	100	100	225	800	150	-
	<b>Existing</b>	200	20	30	225	65	245	25	-
	<b>Near-Term</b>	205	25	30	230	65	250	30	-
	<b>Near-Term Plus Project</b>	225	25	30	285	70	235	30	-
	<b>Cumulative</b>	220	25	30	240	65	275	30	-
	<b>Cumulative Plus Project</b>	225	25	30	245	65	275	50	-
Intersection 15: Central Parkway & Panorama Drive/Pino Grande Road	<b>Storage</b>	-	-	-	100	275	-	100	-
	<b>Existing</b>	-	-	-	5	5	-	0	-
	<b>Near-Term</b>	-	-	-	5	5	-	0	-
	<b>Near-Term Plus Project</b>	-	-	-	5	5	-	0	-
	<b>Cumulative</b>	-	-	-	5	5	-	0	-

AM Peak Hour 95 <sup>th</sup> Percentile Queues in Feet (Rounded Up to Nearest 5 Feet)									
Intersection		NBL	NBR	SBL	SBR	EBL	EBR	WBL	WBR
	<b>Cumulative Plus Project</b>	-	-	-	5	5	-	5	-
Intersection 16: Airway Boulevard & N. Canyons Parkway	<b>Storage</b>	535	535	-	-	-	500	110	-
	<b>Existing</b>	165	55	-	-	-	70	70	-
	<b>Near-Term</b>	335	65	-	-	-	100	130	-
	<b>Near-Term Plus Project</b>	335	65	-	-	-	100	130	-
	<b>Cumulative</b>	420	105	-	-	-	190	280	-
	<b>Cumulative Plus Project</b>	435	120	-	-	-	220	310	-
Intersection 17: Airway Boulevard & I-580 WB Ramps	<b>Storage</b>	-	-	-	-	-	-	1400	1400
	<b>Existing</b>	-	-	-	-	-	-	35	75
	<b>Near-Term</b>	-	-	-	-	-	-	30	150
	<b>Near-Term Plus Project</b>	-	-	-	-	-	-	30	150
	<b>Cumulative</b>	-	-	-	-	-	-	30	725
	<b>Cumulative Plus Project</b>	-	-	-	-	-	-	35	565
Intersection 18: Dublin Boulevard & Commercial Access Driveway	<b>Storage</b>	-	-	-	-	-	-	-	-
	<b>Existing</b>	-	-	-	-	-	-	-	-
	<b>Near-Term</b>	-	-	-	-	-	-	-	-
	<b>Near-Term Plus Project</b>	-	-	-	-	-	-	-	-
	<b>Cumulative</b>	-	-	-	-	-	-	-	-
	<b>Cumulative Plus Project</b>	80	-	25	35	270	415	0	-
Intersection 19: Pandora Way & Residential Project Access Driveway (Parcel 7)	<b>Storage</b>	-	-	-	-	-	-	-	-
	<b>Existing</b>	-	-	-	-	-	-	-	-
	<b>Near-Term</b>	-	-	-	-	-	-	-	-

AM Peak Hour 95 <sup>th</sup> Percentile Queues in Feet (Rounded Up to Nearest 5 Feet)									
Intersection		NBL	NBR	SBL	SBR	EBL	EBR	WBL	WBR
	<b>Near-Term Plus Project</b>	-	-	-	-	-	-	-	-
	<b>Cumulative</b>	-	-	-	-	-	-	-	-
	<b>Cumulative Plus Project</b>	-	-	-	-	-	-	-	-
Intersection 20: Croak Road & Central Parkway	<b>Storage</b>	-	-	-	-	-	-	-	-
	<b>Existing</b>	-	-	-	-	-	-	-	-
	<b>Near-Term</b>	-	-	-	-	-	-	-	-
	<b>Near-Term Plus Project</b>	-	-	-	-	-	-	-	-
	<b>Cumulative</b>	-	-	-	-	-	-	-	-
	<b>Cumulative Plus Project</b>	-	-	-	-	-	-	-	-
Intersection 21: Croak Road & Project Access (Parcel 8)	<b>Storage</b>	-	-	-	-	-	-	-	-
	<b>Existing</b>	-	-	-	-	-	-	-	-
	<b>Near-Term</b>	-	-	-	-	-	-	-	-
	<b>Near-Term Plus Project</b>	-	-	-	-	-	-	-	-
	<b>Cumulative</b>	-	-	-	-	-	-	-	-
	<b>Cumulative Plus Project</b>	-	-	-	-	-	-	-	-
Intersection 22: Croak Road & Dublin Boulevard	<b>Storage</b>	-	-	-	-	-	-	-	-
	<b>Existing</b>	-	-	-	-	-	-	-	-
	<b>Near-Term</b>	-	-	-	-	-	-	-	-
	<b>Near-Term Plus Project</b>	-	-	-	-	-	-	-	-
	<b>Cumulative</b>	0	-	105	-	0	0	0	10
	<b>Cumulative Plus Project</b>	45	-	120	-	205	120	380	55

Source: Kittelson & Associates, 2024 based on Highway Capacity Manual, 7<sup>th</sup> Edition Methodologies

Notes: Queues in feet rounded up to nearest 5 foot increment; Grey highlighted cells indicate 95<sup>th</sup> percentile queues exceeding the available storage; "-" indicates turn pocket does not exist.

**Table 12: PM Peak Hour 95th Percentile Queue in Feet**

PM Peak Hour 95 <sup>th</sup> Percentile Queues in Feet (Rounded Up to Nearest 5 Feet)									
Intersection		NBL	NBR	SBL	SBR	EBL	EBR	WBL	WBR
Intersection 1: Hacienda Drive & Dublin Boulevard	<b>Storage</b>	250	380	300	220	300	250	275	-
	<b>Existing</b>	90	210	55	100	105	70	145	-
	<b>Near-Term</b>	125	215	55	95	140	115	160	-
	<b>Near-Term Plus Project</b>	130	225	55	95	140	135	175	-
	<b>Cumulative</b>	220	210	55	80	280	310	200	-
	<b>Cumulative Plus Project</b>	255	245	55	80	200	330	225	-
Intersection 2: Tassajara Road & Central Parkway	<b>Storage</b>	325	325	300	215	225	225	300	-
	<b>Existing</b>	110	130	35	35	115	160	120	-
	<b>Near-Term</b>	110	160	40	35	115	200	135	-
	<b>Near-Term Plus Project</b>	110	160	40	35	115	200	135	-
	<b>Cumulative</b>	110	240	55	50	115	275	175	-
	<b>Cumulative Plus Project</b>	115	230	45	50	115	355	170	-
Intersection 3: Tassajara Road & Dublin Boulevard	<b>Storage</b>	380	250	295	290	265	330	395	-
	<b>Existing</b>	120	555	50	60	160	205	170	-
	<b>Near-Term</b>	125	1200	90	65	165	205	220	-
	<b>Near-Term Plus Project</b>	125	1260	90	65	165	205	220	-
	<b>Cumulative</b>	140	3830	230	75	190	215	430	-
	<b>Cumulative Plus Project</b>	145	3665	225	90	195	225	430	-
Intersection 4: Tassajara Road & I-580 WB Ramps	<b>Storage</b>	-	-	-	-	-	-	1325	1325
	<b>Existing</b>	-	-	-	-	-	-	160	75
	<b>Near-Term</b>	-	-	-	-	-	-	160	75
	<b>Near-Term Plus Project</b>	-	-	-	-	-	-	160	75

PM Peak Hour 95 <sup>th</sup> Percentile Queues in Feet (Rounded Up to Nearest 5 Feet)									
Intersection		NBL	NBR	SBL	SBR	EBL	EBR	WBL	WBR
	<b>Cumulative</b>	-	-	-	-	-	-	160	80
	<b>Cumulative Plus Project</b>	-	-	-	-	-	-	200	95
Intersection 5: Santa Rita Rd & I-580 EB Ramps/Pimlico Dr	<b>Storage</b>	-	-	425	-	625	-	200	250
	<b>Existing</b>	-	-	380	-	315	-	85	245
	<b>Near-Term</b>	-	-	390	-	340	-	85	245
	<b>Near-Term Plus Project</b>	-	-	390	-	345	-	85	245
	<b>Cumulative</b>	-	-	440	-	425	-	85	245
	<b>Cumulative Plus Project</b>	-	-	500	-	465	-	85	245
Intersection 6: Tassajara Road & Fallon Road	<b>Storage</b>	175	175	175	225	475	175	100	100
	<b>Existing</b>	30	10	5	70	85	25	5	5
	<b>Near-Term</b>	30	10	5	75	100	25	5	5
	<b>Near-Term Plus Project</b>	30	10	5	75	105	25	5	5
	<b>Cumulative</b>	35	10	10	100	170	35	5	10
	<b>Cumulative Plus Project</b>	35	10	10	95	145	30	5	5
Intersection 7: Fallon Road & Positano Parkway	<b>Storage</b>	-	225	335	-	-	-	-	-
	<b>Existing</b>	-	90	40	-	-	-	45	35
	<b>Near-Term</b>	-	110	75	-	-	-	60	40
	<b>Near-Term Plus Project</b>	-	110	75	-	-	-	60	40
	<b>Cumulative</b>	-	200	270	-	-	-	120	60
	<b>Cumulative Plus Project</b>	-	235	205	-	-	-	95	110
Intersection 8: Fallon Road & Central Parkway	<b>Storage</b>	300	255	295	245	350	230	250	250
	<b>Existing</b>	50	90	25	65	40	40	65	25

PM Peak Hour 95 <sup>th</sup> Percentile Queues in Feet (Rounded Up to Nearest 5 Feet)									
Intersection		NBL	NBR	SBL	SBR	EBL	EBR	WBL	WBR
	<b>Near-Term</b>	50	90	30	70	40	55	65	25
	<b>Near-Term Plus Project</b>	50	145	30	70	40	60	75	30
	<b>Cumulative</b>	60	110	35	85	55	265	85	30
	<b>Cumulative Plus Project</b>	75	125	35	80	80	270	95	30
Intersection 9: Fallon Road & Dublin Boulevard	<b>Storage</b>	430	-	140	225	400	400	-	-
	<b>Existing</b>	125	165	0	80	185	245	0	0
	<b>Near-Term</b>	175	335	0	125	185	195	0	0
	<b>Near-Term Plus Project</b>	175	355	0	130	200	195	0	0
	<b>Cumulative</b>	240	75	210	195	215	170	115	50
	<b>Cumulative Plus Project</b>	350	340	390	350	295	285	795	250
Intersection 10: Fallon Road & Fallon Gateway	<b>Storage</b>	275	-	-	-	210	210	-	-
	<b>Existing</b>	90	-	-	-	20	65	-	-
	<b>Near-Term</b>	100	-	-	-	20	75	-	-
	<b>Near-Term Plus Project</b>	100	-	-	-	20	75	-	-
	<b>Cumulative</b>	110	-	-	-	25	80	-	-
	<b>Cumulative Plus Project</b>	145	-	215	-	35	160	450	105
Intersection 11: Fallon Road & I-580 WB Ramps	<b>Storage</b>	-	-	-	225	-	-	1550	1550
	<b>Existing</b>	-	-	-	170	-	-	85	155
	<b>Near-Term</b>	-	-	-	190	-	-	110	170
	<b>Near-Term Plus Project</b>	-	-	-	200	-	-	110	170
	<b>Cumulative</b>	-	-	-	220	-	-	170	170
	<b>Cumulative Plus Project</b>	-	-	-	1985	-	-	140	190



PM Peak Hour 95 <sup>th</sup> Percentile Queues in Feet (Rounded Up to Nearest 5 Feet)									
Intersection		NBL	NBR	SBL	SBR	EBL	EBR	WBL	WBR
Intersection 12: El Charro Road & I-580 EB Ramps	<b>Storage</b>	-	-	-	-	605	605	-	-
	<b>Existing</b>	-	-	-	-	30	25	-	-
	<b>Near-Term</b>	-	-	-	-	30	30	-	-
	<b>Near-Term Plus Project</b>	-	-	-	-	30	30	-	-
	<b>Cumulative</b>	-	-	-	-	40	45	-	-
	<b>Cumulative Plus Project</b>	-	-	-	-	55	40	-	-
Intersection 13: El Charro Road & Jack London Boulevard	<b>Storage</b>	125	-	650	450	450	325	400	775
	<b>Existing</b>	5	-	75	130	55	5	5	55
	<b>Near-Term</b>	10	-	105	160	80	25	15	80
	<b>Near-Term Plus Project</b>	10	-	105	160	80	25	15	80
	<b>Cumulative</b>	80	-	320	380	255	190	80	190
	<b>Cumulative Plus Project</b>	310	-	355	340	275	235	100	195
Intersection 14: Central Parkway & Sunset View Drive	<b>Storage</b>	250	250	100	100	225	800	150	-
	<b>Existing</b>	5	5	5	20	25	5	0	-
	<b>Near-Term</b>	5	5	5	20	25	5	5	-
	<b>Near-Term Plus Project</b>	5	5	5	25	25	5	5	-
	<b>Cumulative</b>	5	5	5	20	25	10	5	-
	<b>Cumulative Plus Project</b>	10	5	5	25	25	5	10	-
Intersection 15: Central Parkway & Panorama Drive/Pino Grande Road	<b>Storage</b>	-	-	-	100	275	-	100	-
	<b>Existing</b>	-	-	-	5	5	-	0	-
	<b>Near-Term</b>	-	-	-	5	5	-	0	-
	<b>Near-Term Plus Project</b>	-	-	-	5	5	-	0	-
	<b>Cumulative</b>	-	-	-	5	5	-	0	-

PM Peak Hour 95 <sup>th</sup> Percentile Queues in Feet (Rounded Up to Nearest 5 Feet)									
Intersection		NBL	NBR	SBL	SBR	EBL	EBR	WBL	WBR
	<b>Cumulative Plus Project</b>	-	-	-	5	5	-	5	-
Intersection 16: Airway Boulevard & N. Canyons Parkway	<b>Storage</b>	535	535	-	-	-	500	110	-
	<b>Existing</b>	185	70	-	-	-	145	200	-
	<b>Near-Term</b>	190	150	-	-	-	310	275	-
	<b>Near-Term Plus Project</b>	190	150	-	-	-	310	275	-
	<b>Cumulative</b>	85	350	-	-	-	1705	920	-
	<b>Cumulative Plus Project</b>	120	360	-	-	-	1395	905	-
Intersection 17: Airway Boulevard & I-580 WB Ramps	<b>Storage</b>	-	-	-	-	-	-	1400	1400
	<b>Existing</b>	-	-	-	-	-	-	30	100
	<b>Near-Term</b>	-	-	-	-	-	-	35	105
	<b>Near-Term Plus Project</b>	-	-	-	-	-	-	35	105
	<b>Cumulative</b>	-	-	-	-	-	-	35	120
	<b>Cumulative Plus Project</b>	-	-	-	-	-	-	35	140
Intersection 18: Dublin Boulevard & Commercial Access Driveway	<b>Storage</b>	-	-	-	-	-	-	-	-
	<b>Existing</b>	-	-	-	-	-	-	-	-
	<b>Near-Term</b>	-	-	-	-	-	-	-	-
	<b>Near-Term Plus Project</b>	-	-	-	-	-	-	-	-
	<b>Cumulative</b>	-	-	-	-	-	-	-	-
	<b>Cumulative Plus Project</b>	545	-	95	365	145	180	0	-
Intersection 19: Pandora Way & Residential Project Access Driveway (Parcel 7)	<b>Storage</b>	-	-	-	-	-	-	-	-
	<b>Existing</b>	-	-	-	-	-	-	-	-
	<b>Near-Term</b>	-	-	-	-	-	-	-	-

PM Peak Hour 95 <sup>th</sup> Percentile Queues in Feet (Rounded Up to Nearest 5 Feet)									
Intersection		NBL	NBR	SBL	SBR	EBL	EBR	WBL	WBR
	<b>Near-Term Plus Project</b>	-	-	-	-	-	-	-	-
	<b>Cumulative</b>	-	-	-	-	-	-	-	-
	<b>Cumulative Plus Project</b>	-	-	-	-	-	-	-	-
Intersection 20: Croak Road & Central Parkway	<b>Storage</b>	-	-	-	-	-	-	-	-
	<b>Existing</b>	-	-	-	-	-	-	-	-
	<b>Near-Term</b>	-	-	-	-	-	-	-	-
	<b>Near-Term Plus Project</b>	-	-	-	-	-	-	-	-
	<b>Cumulative</b>	-	-	-	-	-	-	-	-
	<b>Cumulative Plus Project</b>	-	-	-	-	-	-	-	-
Intersection 21: Croak Road & Project Access (Parcel 8)	<b>Storage</b>	-	-	-	-	-	-	-	-
	<b>Existing</b>	-	-	-	-	-	-	-	-
	<b>Near-Term</b>	-	-	-	-	-	-	-	-
	<b>Near-Term Plus Project</b>	-	-	-	-	-	-	-	-
	<b>Cumulative</b>	-	-	-	-	-	-	-	-
	<b>Cumulative Plus Project</b>	-	-	-	-	-	-	-	-
Intersection 22: Croak Road & Dublin Boulevard	<b>Storage</b>	-	-	-	-	-	-	-	-
	<b>Existing</b>	-	-	-	-	-	-	-	-
	<b>Near-Term</b>	-	-	-	-	-	-	-	-
	<b>Near-Term Plus Project</b>	-	-	-	-	-	-	-	-
	<b>Cumulative</b>	0	-	20	-	75	0	10	20
	<b>Cumulative Plus Project</b>	365	-	105	-	210	45	195	55

Source: Kittelson & Associates, 2024 based on Highway Capacity Manual, 7<sup>th</sup> Edition Methodologies

Notes: Queues in feet rounded up to nearest 5 foot increment; Grey highlighted cells indicate 95<sup>th</sup> percentile queues exceeding the available storage; "-" indicates turn pocket does not exist.

## CMP ASSESSMENT

This section presents the findings of the Alameda CTC Land Use analysis under Existing Conditions and Cumulative Conditions with and without the Project. The Alameda County Transportation Commission (Alameda CTC) Land Use analysis was performed to comply with its congestion management plan (CMP) Land Use Analysis Program. In the CMP, development projects generating more than 100 PM net new peak hour trips are analyzed to determine their effect on Metropolitan Transportation System (MTS) roadways. Since the Alameda CTC Land Use Analysis Program's 100-trip criteria is in the PM peak hour this analysis was evaluated in the PM peak hour only.

The city of Dublin's travel demand model, which is a more refined version of the Alameda CTC travel demand model for Dublin, was used to determine the project's effect on V/C ratio for the base year (2020) and future year (2040) models. Kittelson used the model to determine volume, capacity, and V/C ratio for all Tier 1 and Tier 2 CMP segments in the city of Dublin located east of Interstate 680. This included the Interstate 580 freeway, Dublin Boulevard, Fallon Road, Dougherty Road, Tassajara Road, and Village Parkway.

The findings of the CMP analysis using the city of Dublin's travel demand model for volume, capacity, an V/C ratio is shown in Table 13 and Table 14 for existing and 2040 conditions with and without project, respectively. Alameda CTC does not have an adopted threshold for determining when a CMP segment is affected by a land use analysis project. Past analyses within the city of Dublin have used the following criteria to assess CMP roadway segment effects:

- For a roadway segment of the Alameda CTC CMP Network, the project would cause (a) the LOS to degrade from LOS E or better to LOS F or (b) the v/c ratio to increase by 0.02 or more for a roadway segment that would operate at LOS F without the project.

As shown in Table 13 and Table 14, some CMP segments were found to operate at LOS F. However, the Project did not result in any CMP segments deteriorating to LOS F or increase the V/C ratio for an intersection already at LOS F by 0.02 or more. Therefore, the Project is not anticipated to have a substantial effect on CMP segments in the city of Dublin.

**Table 13: Analysis of CMP Segments for Existing Conditions**

CMP ID	CMP Route	From	To	# of Lanes	Capacity (vphpl)	Existing No Project			Existing Plus Project			Project Trips	Δ V/C
						Volume (vph)	LOS	V/C	Volume (vph)	LOS	V/C		
F21	I-580 - EB	I-680	Hopyard	6	13,200	10,063	D	0.76	10,104	D	0.77	41	0.00
F22	I-580 - EB	Hopyard	Santa Rita	5	9,900	8,785	D	0.89	8,899	D	0.90	114	0.01
F23	I-580 - EB	Santa Rita	El Charro	5	9,900	9,368	E	0.95	9,389	E	0.95	21	0.00
F24	I-580 - EB	El Charro	SR 84/Airway Blvd.	5	9,900	<b>10,170</b>	<b>F</b>	<b>1.03</b>	<b>10,184</b>	<b>F</b>	<b>1.03</b>	14	0.00
F37	I-580 - WB	SR 84/Airway Blvd	Fallon Rd/El Charro	5	9,900	5,959	C	0.60	5,962	C	0.60	3	0.00
F38	I-580 - WB	Fallon Rd/El Charro	Tassajara	5	9,900	5,928	C	0.60	5,938	C	0.60	10	0.00
F39	I-580 - WB	Tassajara Rd	I-680	5	9,900	7,315	C	0.74	7,323	C	0.74	8	0.00
T145	Dublin Blvd.-EB	Village Parkway	Dougherty Rd	3	3,300	887	A	0.27	896	A	0.27	9	0.00
T146	Dublin Blvd.-EB	Dougherty Rd	Hacienda Dr	3	3,300	2,242	B	0.68	2,197	B	0.67	-45	-0.01
T147	Dublin Blvd.-EB	Hacienda Dr	Tassajara Dr	3	3,300	2,979	D	0.90	2,941	D	0.89	-38	-0.01
T334	Dublin Blvd.-EB	Tassajara Road	Fallon Road	3	3,150	1,071	A	0.34	1,079	A	0.34	8	0.00
T231	Dublin Blvd.-WB	Fallon Road	Tassajara Road	3	3,150	165	A	0.05	170	A	0.05	5	0.00
T148	Dublin Blvd.-WB	Tassajara Dr	Hacienda Dr	3	3,300	233	A	0.07	237	A	0.07	4	0.00
T149	Dublin Blvd.-WB	Hacienda Dr	Dougherty Rd	3	3,300	91	A	0.03	91	A	0.03	0	0.00
T150	Dublin Blvd.-WB	Dougherty Rd	Village Parkway	3	3,300	541	A	0.16	540	A	0.16	-1	0.00
T239	Fallon Rd.-NB	I-580	Tassajara Road	3	3,150	1,088	A	0.35	1,171	A	0.37	83	0.03
T342	Fallon Rd.-SB	Tassajara Road	I-580	3	3,150	534	A	0.17	553	A	0.18	19	0.01
T156	Dougherty Road-NB	WB I-580 OFF ramp	Amador Valley Blvd on SB	3	3,300	3,292	E	1.00	3,286	E	1.00	-6	0.00
T157	Dougherty Road-NB	Amador Valley Blvd on SB	Fallcreek Rd on SB/County Line	3	3,150	2,657	D	0.84	2,654	D	0.84	-3	0.00

CMP ID	CMP Route	From	To	# of Lanes	Capacity (vphpl)	Existing No Project			Existing Plus Project			Project Trips	Δ V/C
						Volume (vph)	LOS	V/C	Volume (vph)	LOS	V/C		
T158	Dougherty Road-SB	Fallcreek Rd on SB/County Line	Amador Valley Blvd on SB	3	3,150	743	A	0.24	744	A	0.24	1	0.00
T159	Dougherty Road-SB	Amador Valley Blvd on SB	WB I-580 OFF ramp	4	4,400	1,184	A	0.27	1,189	A	0.27	5	0.00
T160	Tassajara Road-NB	WB I-580 OFF ramp	Central Parkway	2	2,100	2,093	E	1.00	2,093	E	1.00	0	0.00
T161	Tassajara Road-NB	Central Parkway	Somerset Ln/N Dublin Ranch Dr	2	2,100	1,373	B	0.65	1,380	B	0.66	7	0.00
T162	Tassajara Road-NB	Somerset Ln/N Dublin Ranch Dr	Fallon Rd	1	1,050	625	A	0.60	627	A	0.60	2	0.00
T163	Tassajara Road-NB	Fallon Rd	County Line	1	1,050	833	C	0.79	837	C	0.80	4	0.00
T164	Tassajara Road-SB	County Line	Fallon Rd	1	1,050	450	A	0.43	452	A	0.43	2	0.00
T165	Tassajara Road-SB	Fallon Rd	Somerset Ln/N Dublin Ranch Dr	1	1,050	283	A	0.27	282	A	0.27	-1	0.00
T166	Tassajara Road-SB	Somerset Ln/N Dublin Ranch Dr	Central Parkway	2	2,100	485	A	0.23	488	A	0.23	3	0.00
T167	Tassajara Road-SB	Central Parkway	WB I-580 OFF ramp	3	3,150	845	A	0.27	847	A	0.27	2	0.00
T291	Village Parkway - NB	Dublin Boulevard	County Line	2	2,100	649	A	0.31	646	A	0.31	-3	0.00
T394	Village Parkway - SB	Dublin Boulevard	County Line	2	2,100	445	A	0.21	440	A	0.21	-5	0.00

Source: Kittelson & Associates, 2024 based on CMP Segment information from the city of Dublin's Travel Demand Model

Notes: Bolded text indicates LOS below the CMP standard; V/C = Volume to Capacity Ratio.

**Table 14: Analysis of CMP Segments for 2040 Conditions**

CMP ID	CMP Route	From	To	# of Lanes	Capacity (vphpl)	2040 No Project			2040 Plus Project			Project Trips	Δ V/C
						Volume (vph)	LOS	V/C	Volume (vph)	LOS	V/C		
F21	I-580 - EB	I-680	Hopyard	6	13,500	10,242	D	0.76	10,193	D	0.76	-49	0.00
F22	I-580 - EB	Hopyard	Santa Rita	5	10,125	9,478	E	0.94	9,443	E	0.93	-35	0.00

CMP ID	CMP Route	From	To	# of Lanes	Capacity (vphpl)	2040 No Project			2040 Plus Project			Project Trips	Δ V/C
						Volume (vph)	LOS	V/C	Volume (vph)	LOS	V/C		
F23	I-580 - EB	Santa Rita	El Charro	5	10,125	10,125	F	1.00	10,172	F	1.00	47	0.00
F24	I-580 - EB	El Charro	SR 84/Airway Blvd.	5	10,125	10,807	F	1.07	10,923	F	1.08	116	0.01
F37	I-580 - WB	SR 84/Airway Blvd	Fallon Rd/El Charro	5	10,125	6,837	C	0.68	6,763	C	0.67	-74	-0.01
F38	I-580 - WB	Fallon Rd/El Charro	Tassajara	5	10,125	6,806	C	0.67	7,290	C	0.72	484	0.05
F39	I-580 - WB	Tassajara Rd	I-680	5	10,125	8,099	D	0.80	8,273	D	0.82	174	0.02
T145	Dublin Blvd.-EB	Village Parkway	Dougherty Rd	3	3,300	1,421	A	0.43	1,391	A	0.42	-30	-0.01
T146	Dublin Blvd.-EB	Dougherty Rd	Hacienda Dr	3	3,300	2,932	D	0.89	2,894	D	0.88	-38	-0.01
T147	Dublin Blvd.-EB	Hacienda Dr	Tassajara Dr	3	3,300	3,207	E	0.97	3,264	E	0.99	57	0.02
T334	Dublin Blvd.-EB	Tassajara Road	Fallon Road	3	3,150	2,759	D	0.88	2,652	D	0.84	-107	-0.03
T231	Dublin Blvd.-WB	Fallon Road	Tassajara Road	3	3,150	426	A	0.14	523	A	0.17	97	0.03
T148	Dublin Blvd.-WB	Tassajara Dr	Hacienda Dr	3	3,300	424	A	0.13	485	A	0.15	61	0.02
T149	Dublin Blvd.-WB	Hacienda Dr	Dougherty Rd	3	3,300	471	A	0.14	557	A	0.17	86	0.03
T150	Dublin Blvd.-WB	Dougherty Rd	Village Parkway	3	3,300	1,126	A	0.34	1,248	A	0.38	122	0.04
T239	Fallon Rd.-NB	I-580	Tassajara Road	3	3,150	1,027	A	0.33	1,209	A	0.38	182	0.06
T342	Fallon Rd.-SB	Tassajara Road	I-580	3	3,150	1,045	A	0.33	1,072	A	0.34	27	0.01
T156	Dougherty Road-NB	WB I-580 OFF ramp	Amador Valley Blvd on SB	3	3,300	3,244	E	0.98	3,254	E	0.99	10	0.00
T157	Dougherty Road-NB	Amador Valley Blvd on SB	Fallcreek Rd on SB/County Line	3	3,150	2,907	E	0.92	2,911	E	0.92	4	0.00
T158	Dougherty Road-SB	Fallcreek Rd on SB/County Line	Amador Valley Blvd on SB	3	3,150	920	A	0.29	909	A	0.29	-11	0.00
T159	Dougherty Road-SB	Amador Valley Blvd on SB	WB I-580 OFF ramp	4	3,300	1,073	A	0.33	1,044	A	0.32	-29	-0.01
T160	Tassajara Road-NB	WB I-580 OFF ramp	Central Parkway	2	2,100	1,789	D	0.85	1,830	D	0.87	41	0.02

CMP ID	CMP Route	From	To	# of Lanes	Capacity (vphpl)	2040 No Project			2040 Plus Project			Project Trips	Δ V/C
						Volume (vph)	LOS	V/C	Volume (vph)	LOS	V/C		
T161	Tassajara Road-NB	Central Parkway	Somerset Ln/N Dublin Ranch Dr	2	2,100	1,680	C	0.80	1,598	C	0.76	-82	-0.04
T162	Tassajara Road-NB	Somerset Ln/N Dublin Ranch Dr	Fallon Rd	2	2,100	894	A	0.43	824	A	0.39	-70	-0.03
T163	Tassajara Road-NB	Fallon Rd	County Line	2	2,100	1,064	A	0.51	1,068	A	0.51	4	0.00
T164	Tassajara Road-SB	County Line	Fallon Rd	2	2,100	823	A	0.39	768	A	0.37	-55	-0.03
T165	Tassajara Road-SB	Fallon Rd	Somerset Ln/N Dublin Ranch Dr	2	2,100	346	A	0.16	354	A	0.17	8	0.00
T166	Tassajara Road-SB	Somerset Ln/N Dublin Ranch Dr	Central Parkway	2	2,100	553	A	0.26	556	A	0.26	3	0.00
T167	Tassajara Road-SB	Central Parkway	WB I-580 OFF ramp	3	3,150	1,036	A	0.33	1,145	A	0.36	109	0.03
T291	Village Parkway - NB	Dublin Boulevard	County Line	2	2,100	1,192	A	0.57	1,265	A	0.60	73	0.03
T394	Village Parkway - SB	Dublin Boulevard	County Line	2	2,100	733	A	0.35	723	A	0.34	-10	0.00

Source: Kittelson & Associates, 2024 based on CMP Segment information from the city of Dublin's Travel Demand Model

Notes: Bolded text indicates LOS below the CMP standard; V/C = Volume to Capacity Ratio.



# PARKING ASSESSMENT

The residential units for the Project are in two different parcels. Parcel 7 is accessed off Pandora Way and Pino Grande Road and contains 128 residential units. Parcel 8 is accessed off Croak Road and contains 110 units. This section analyzes whether these two parcels provide adequate parking to meet the requirements of Dublin’s municipal code. Dublin’s municipal code requires residential units that are townhouses similar to the Project to provide two enclosed garage parking spaces per unit and one on-street parking space located within 150 feet of the unit. The site plans dated February 2024 show slightly fewer parking spaces indicating a request for a parking requirement reduction. Table 15 provides a comparison between the required parking per the Dublin Municipal Code and the provided parking detailed in the site plan. As shown, guest parking has about ten (10) fewer spaces than the parking required per the municipal code.

**Table 15: Municipal Code Required Vs. Site Plan Provided Residential Parking**

	Units	Municipal Code		Site Plan	
		Enclosed	Guest	Enclosed	Guest
Parcel 7	128	256	128	256	120
Parcel 8	110	220	110	220	108
Total	238	476	238	476	228

To assess whether the loss of ten parking spaces is significant, Kittelson reviewed the Institute of Transportation Engineers’ (ITE) Parking Generation Manual 5<sup>th</sup> Edition. This manual does not contain parking studies for single family dwelling units such as the Project’s townhouses. The most similar land use where parking data is available is multifamily housing (low-rise). Table 16 provides a comparison between the municipal code, the site plan total, and the ITE parking generation estimate based on the 33<sup>rd</sup>, average, and 85<sup>th</sup> percentile demand. As shown, both the municipal code and the side plan require/provide significantly more parking than the 85<sup>th</sup> percentile parking generation numbers. This indicates that both Parcel 7 and Parcel 8 should not be affected by the loss of ten parking spaces compared to the code.

**Table 16: ITE Parking Generation Vs. Provides and Municipal Code Requirements**

	Units	Municipal Code Total	Site Plan Total	ITE Parking Generation		
				33rd	Average	85th
Parcel 7	128	384	376	132	155	195
Parcel 8	110	330	328	114	134	168
Total	238	714	704	246	289	363

While a reduction from code requirements of ten parking spaces is unlikely to result in insufficient parking supply, the municipal code does require the guest parking to be within 150 feet of the building. In both Parcel 7 and Parcel 8, some guest parking is available within 150 feet of all the residential units. However, the majority of guest parking is provided at the southern end of the site plan, especially for Parcel 8. If

guest parking were assigned to individual units, there would be many units in the northern part of the site plan that would have their guest parking more than 150 feet from the unit. Kittelson believes this does not align with the municipal code requirements to provide guest parking within 150 feet since most guests visiting residential units in the northern part of the site plan would have to park more than 150 feet from the residential unit.

## 4. DISCUSSION OF EFFECTS & RECOMMENDED IMPROVEMENTS

Based on the operations assessment under existing, near-term, and cumulative conditions, two intersections were identified as experiencing a significant effect because of the Project. Details of the effect and proposed improvements are discussed in this section.

### Fallon Road & Dublin Boulevard

This intersection serves as one of the primary access points serving the approximately 2.9 million square feet of advanced manufacturing land use proposed by the Project. The majority of these jobs are anticipated to depart the Project in the PM peak hour heading west along Dublin Boulevard or making a left onto Fallon Road to access the I-580 freeway. There is little land use to the east or north of the Project which results in a heavy demand for the westbound movements at Fallon Road & Dublin Boulevard. The westbound left turn at this intersection for example is projected to increase from about 190 vehicles to almost 1,200 vehicles. This amount of left turn volume overloads the triple left turn lanes at this location resulting in poor intersection operations.

There are few options at this location to reduce the effect of the Project since it is already operating with triple left turns lanes. Therefore, Kittelson recommends two strategies that can be considered in parallel. The first is an extensive TDM strategy to reduce vehicle trips in the PM peak hour. Kittelson estimated that trip generation in the PM peak hour would need to show more than a 50% reduction to project trips. Should a significant reduction not be feasible, the city should consider requesting upgrades to multimodal infrastructure such as protected bike lanes along Fallon Road in lieu of improvements that benefit vehicles.

In addition to a comprehensive TDM plan, the advanced manufacturing component of the Project should be able to access Fallon Road at the Fallon Gateway intersection. There is additional capacity at this intersection to carry more westbound left turn volumes which would reduce the demand for the westbound left turn at Dublin Boulevard on Fallon Road. The effect on LOS cannot be fully quantified without a detailed site plan which will be needed to make the assignment split between exiting onto Dublin Boulevard or onto Fallon Road via Fallon Gateway.

Once a site plan is submitted, a careful review should be performed to ensure that the demand for vehicles exiting the advanced manufacturing components of the Project are able to distribute as evenly as possible between the two intersections along Fallon Road at Fallon Gateway and Dublin Boulevard.

The layout of this intersection was analyzed to align with the Fallon Road plan line study which calls for four lanes in each direction. This lane alignment and the recommended queue storage for the turn lanes based on cumulative plus project conditions is shown below.

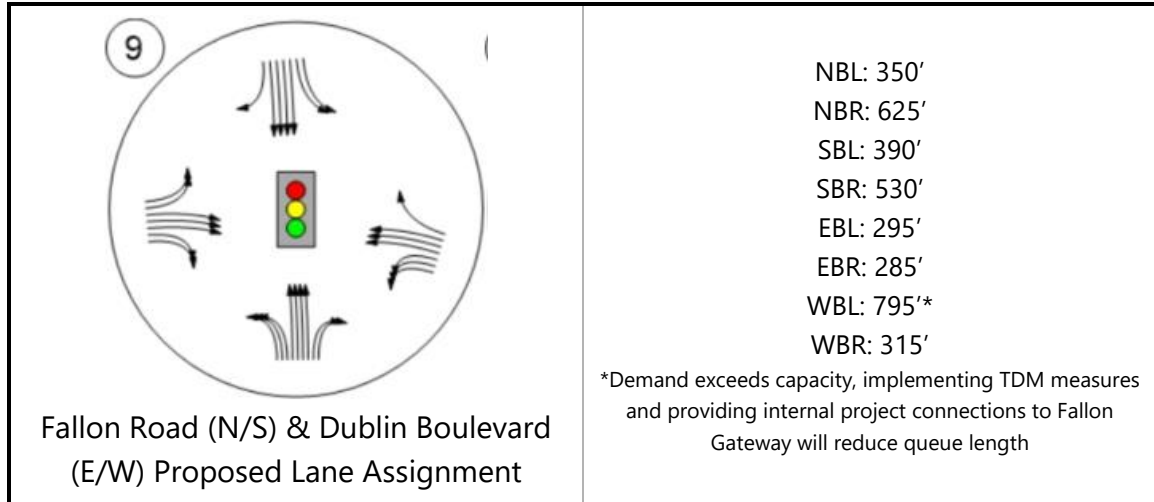

### Fallon Road & Fallon Gateway

As a primary intersection providing access to the Project and one of two allowing access to Fallon Road for Project traffic, this intersection has a high volume of vehicles. Based on the operations analysis the minimum lane configuration for this intersection along with the required queue storage for turn lanes is shown below. A single SB left turn lane into the project should be sufficient. Exiting the project on the east leg should have a double left turn lane, a through lane, and a right turn lane. If an internal connection to the advanced manufacturing land uses connects at Fallon Gateway, the WB left turn storage would increase as left turning vehicles shift from the Fallon Road and Dublin Boulevard intersection.

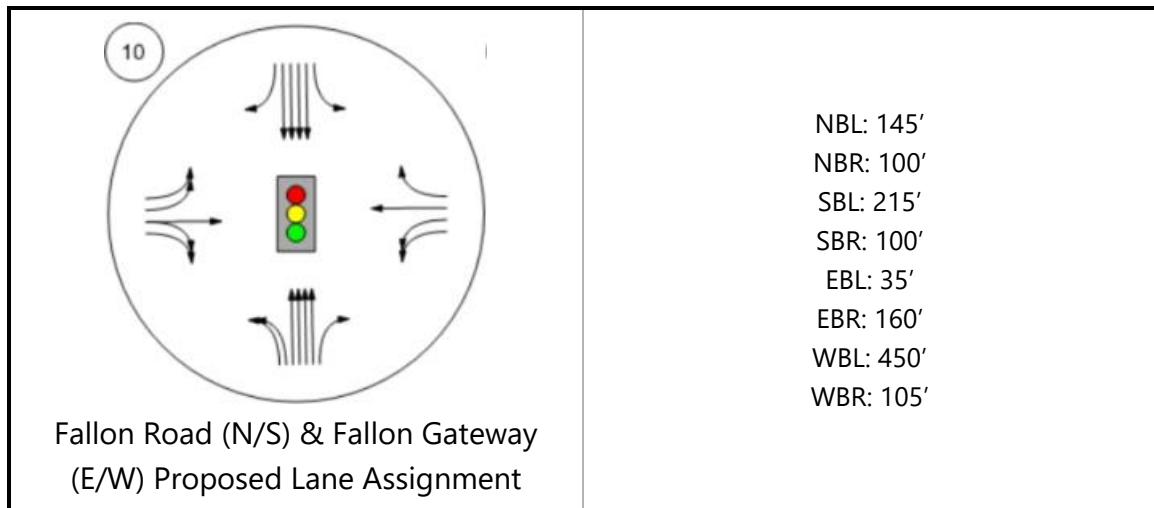

### Dublin Boulevard & Commercial Access

The commercial access to the advanced manufacturing land uses is assumed to connect development parcels north and south of Dublin Boulevard at approximately the half-way point between Fallon Road and Croak Road. Based on our forecasts and operations analysis, the lane configuration and turn storage

for this intersection is shown below. The queue for the northbound left turn lane may be reduced should an internal connection between the advanced manufacturing land uses and Fallon Gateway be provided.

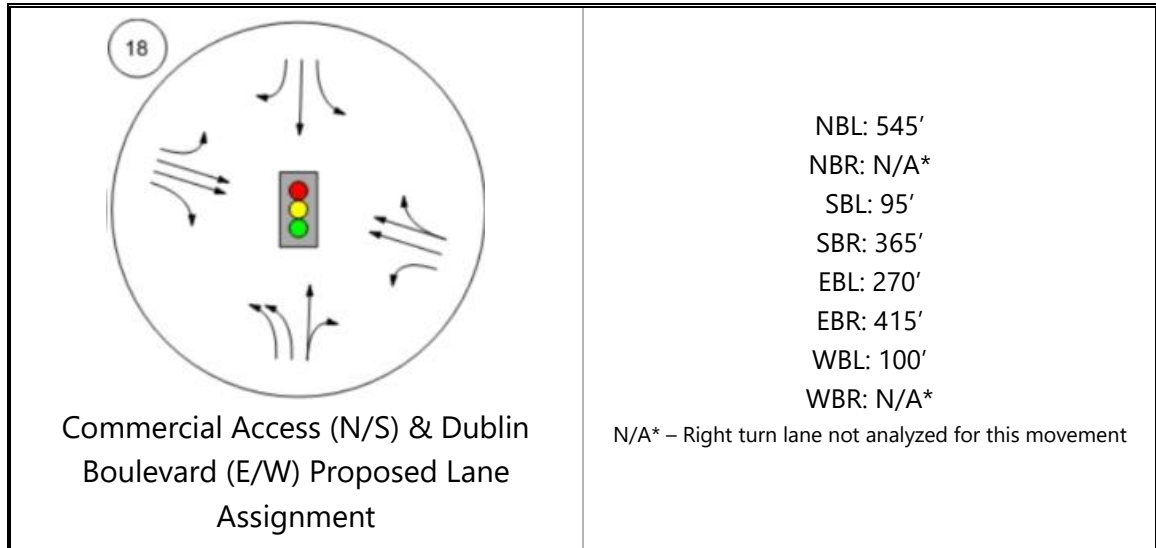

### Dublin Boulevard & Croak Road

Croak Road south of Dublin Boulevard would provide access to the advanced manufacturing land uses located south of Dublin Boulevard. The assumed lane configuration for this intersection and the estimated minimum queue storage based on cumulative conditions forecasts are shown below.

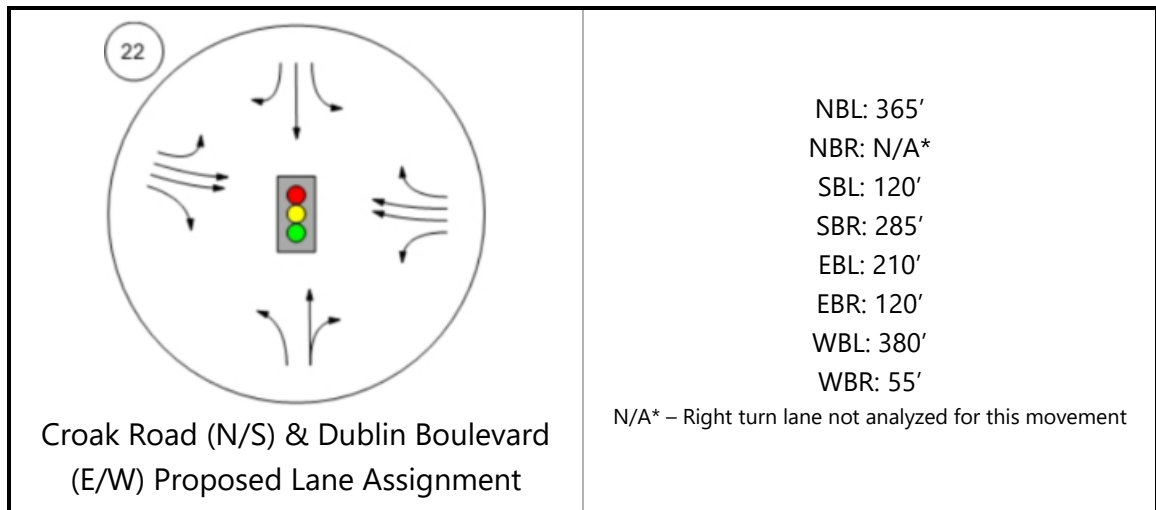

## Fallon Road & I-580 WB Ramps

This intersection represents the primary freeway access intersection for the Project. This results in a degradation of intersection operations for both the AM and PM peak hours. In the AM peak hours, the Project contributes a large volume to the northbound thorough volume (almost 860 vehicles) which are coming from either the eastbound off-ramp or from south of the interchange along El Charro Road for traffic coming from Pleasanton. The reverse is happening in the PM peak hour with the Project adding almost 660 vehicles to the westbound on-ramp and about 300 traveling through the interchange to El Charro Road. The net effect is LOS F operations with the Project.

This intersection has plans to be improved in the future. However, the funding of these improvements is unclear and Kittelson decided on a conservative analysis where the interchange remains under its existing configuration. Based on the Project's effect on the intersection, Kittelson recommends any improvements to the interchange should include at least two northbound through lanes. Adding the additional northbound lane to the existing configuration was found to improve the operations of the westbound ramp terminal intersection to LOS D in both the AM and PM peak hours. It is unlikely this can be achieved without replacing the bridge over I-580 in order to add extra lanes. Therefore, the city should consider requesting a fair share contribution to upgrade the interchange to its ultimate configuration.

## 95<sup>th</sup> Percentile Queue Reduction Recommendations

- ▶ Hacienda Drive & Dublin Boulevard (#1)
  - Given the queue is only projected to exceed the available storage by 5 feet in 2040 with the Project, no recommendations are proposed at this intersection.
- ▶ Tassajara Road & Central Parkway (#2)
  - Due to limited ROW and since the queue storage already exceeds 200 feet, lengthening of the turn lane is not recommended. Kittelson recommends the Project be conditioned to update the signal timing at this location to reduce the EBR queue to the extent feasible.
- ▶ Tassajara Road & Dublin Boulevard (#3)
  - Future forecasts call for a substantial increase for the NBR turn movement at this intersection. A development in the SE corner of this intersection is in the entitlements stage and is anticipated to construct the second NB right turn lane.
- ▶ Santa Rita Rd & I-580 EB Ramps/Pimlico Dr (#5)
  - Limited ROW prevents the extension of the SBL turn pocket or the addition of a second lane. Therefore, it is recommended the Project be conditioned to implement a signal timing improvement project to reduce the SBL turn lane queue to the extent feasible.
- ▶ Fallon Road & Positano Parkway (#7)
  - The queue for the NBR is projected to only exceed the available storage by 10 feet under cumulative plus project conditions. Since this is a future projection and the increase is less than one vehicle length, no improvements at this intersection are recommended.
- ▶ Fallon Road & Central Parkway (#8)
  - There is limited ROW to extend the WBL turn lanes at this intersection and only the near-term condition was found to exceed the available storage. Therefore, it is recommended

the Project be conditioned to implement a signal timing improvement project at this intersection to reduce the WBL turn lane queue to the extent feasible.

- ▶ Fallon Road & Dublin Boulevard (#9)
  - As noted in the operations recommendations above, there is little that can be done at this intersection other than reduce the Project's trip generation since it is assumed to already operated with three left turn lanes. Therefore, the TDM measures such as long-term bicycle lockers, a shuttle service to the nearest BART station, carpool pairing, and vanpool services should be considered. Once a more detailed site plan is established, an effective TDM plan can be developed.
- ▶ Fallon Road & I-580 WB Ramps (#11)
  - The Fallon Road and I-580 interchange is proposed to be improved in the future. The Project should make a fair share contribution to replacing the interchange to reduce the effect of the SBR turn lane queues under cumulative conditions.
- ▶ Airway Boulevard & N. Canyons Parkway (#16)
  - Due to limited ROW, the queue effect occurring under cumulative conditions, and since the intersection is being improved as part of the Dublin Boulevard extension, it is recommended the Dublin Boulevard extension Project reduce queues to the extent feasible as part of the final signal timing plans for the intersection. No recommendations are proposed for the Project's conditions of approval.



## Appendix A: Raw Counts



**LOCATION:** Airway Blvd -- I-580 WB Ramps  
**CITY/STATE:** Livermore, CA

**QC JOB #:** 16444301  
**DATE:** Thu, Jan 18 2024

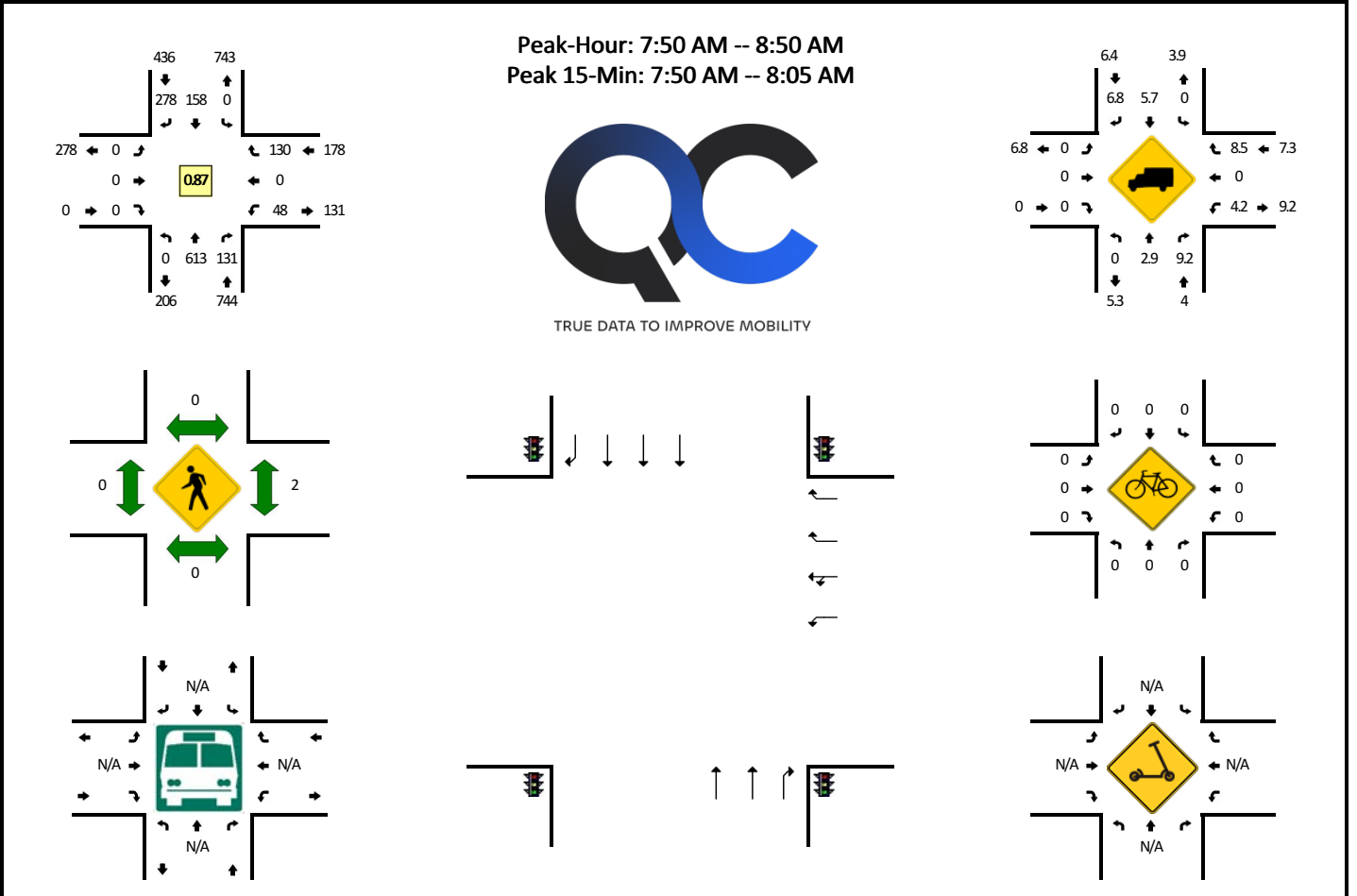

5-Min Count Period Beginning At	Airway Blvd (Northbound)				Airway Blvd (Southbound)				I-580 WB Ramps (Eastbound)				I-580 WB Ramps (Westbound)				Total	Hourly Totals
	Left	Thru	Right	U	Left	Thru	Right	U	Left	Thru	Right	U	Left	Thru	Right	U		
7:00 AM	1	17	9	0	0	3	17	0	0	0	0	0	2	1	11	0	61	
7:05 AM	0	23	10	0	0	8	22	0	0	0	0	0	3	0	10	0	76	
7:10 AM	0	15	10	0	0	15	17	0	0	0	0	0	2	0	5	0	64	
7:15 AM	0	31	10	0	0	5	28	0	0	0	0	0	5	0	6	0	85	
7:20 AM	0	33	10	0	0	14	15	0	0	0	0	0	3	0	7	0	82	
7:25 AM	0	39	5	0	0	9	20	0	0	0	0	0	1	0	5	0	79	
7:30 AM	0	56	7	0	0	20	31	0	0	0	0	0	2	0	11	0	127	
7:35 AM	0	35	10	0	0	11	23	0	0	0	0	0	2	0	4	0	85	
7:40 AM	0	29	9	0	0	19	19	0	0	0	0	0	5	0	6	0	87	
7:45 AM	0	40	9	0	0	19	33	0	0	0	0	0	4	0	12	0	117	
7:50 AM	0	65	11	0	0	23	22	0	0	0	0	0	5	0	8	0	134	
7:55 AM	0	60	14	0	0	11	40	0	0	0	0	0	3	0	14	0	142	1139
8:00 AM	0	42	8	0	0	20	29	0	0	0	0	0	3	0	11	0	113	1191
8:05 AM	0	34	11	0	0	11	21	0	0	0	0	0	3	0	12	0	92	1207
8:10 AM	0	41	10	0	0	10	20	0	0	0	0	0	1	0	12	0	94	1237
8:15 AM	0	55	12	0	0	14	17	0	0	0	0	0	4	0	9	0	111	1263
8:20 AM	0	38	11	0	0	8	30	0	0	0	0	0	7	0	9	0	103	1284
8:25 AM	0	51	9	0	0	16	11	0	0	0	0	0	2	0	5	0	94	1299
8:30 AM	0	59	13	0	0	9	21	0	0	0	0	0	5	0	14	0	121	1293
8:35 AM	0	50	11	0	0	13	22	0	0	0	0	0	3	0	6	0	105	1313
8:40 AM	0	64	6	0	0	15	18	0	0	0	0	0	5	0	11	0	119	1345
8:45 AM	0	54	15	0	0	8	27	0	0	0	0	0	7	0	19	0	130	1358
8:50 AM	0	58	8	0	0	10	21	0	0	0	0	0	8	0	7	0	112	1336
8:55 AM	0	75	9	0	0	9	17	0	0	0	0	0	1	0	13	0	124	1318
Peak 15-Min Flowrates	Northbound				Southbound				Eastbound				Westbound				Total	
	Left	Thru	Right	U	Left	Thru	Right	U	Left	Thru	Right	U	Left	Thru	Right	U		
All Vehicles	0	668	132	0	0	216	364	0	0	0	0	0	44	0	132	0	1556	
Heavy Trucks	0	20	16		0	12	36		0	0	0		0	0	16		100	
Buses																		
Pedestrians	0	0			0	0			0	0			0	4			4	
Bicycles	0	0			0	0			0	0			0	0			0	
Scooters																		

Comments:

**LOCATION:** Airway Blvd -- I-580 WB Ramps  
**CITY/STATE:** Livermore, CA

**QC JOB #:** 16444302  
**DATE:** Thu, Jan 18 2024

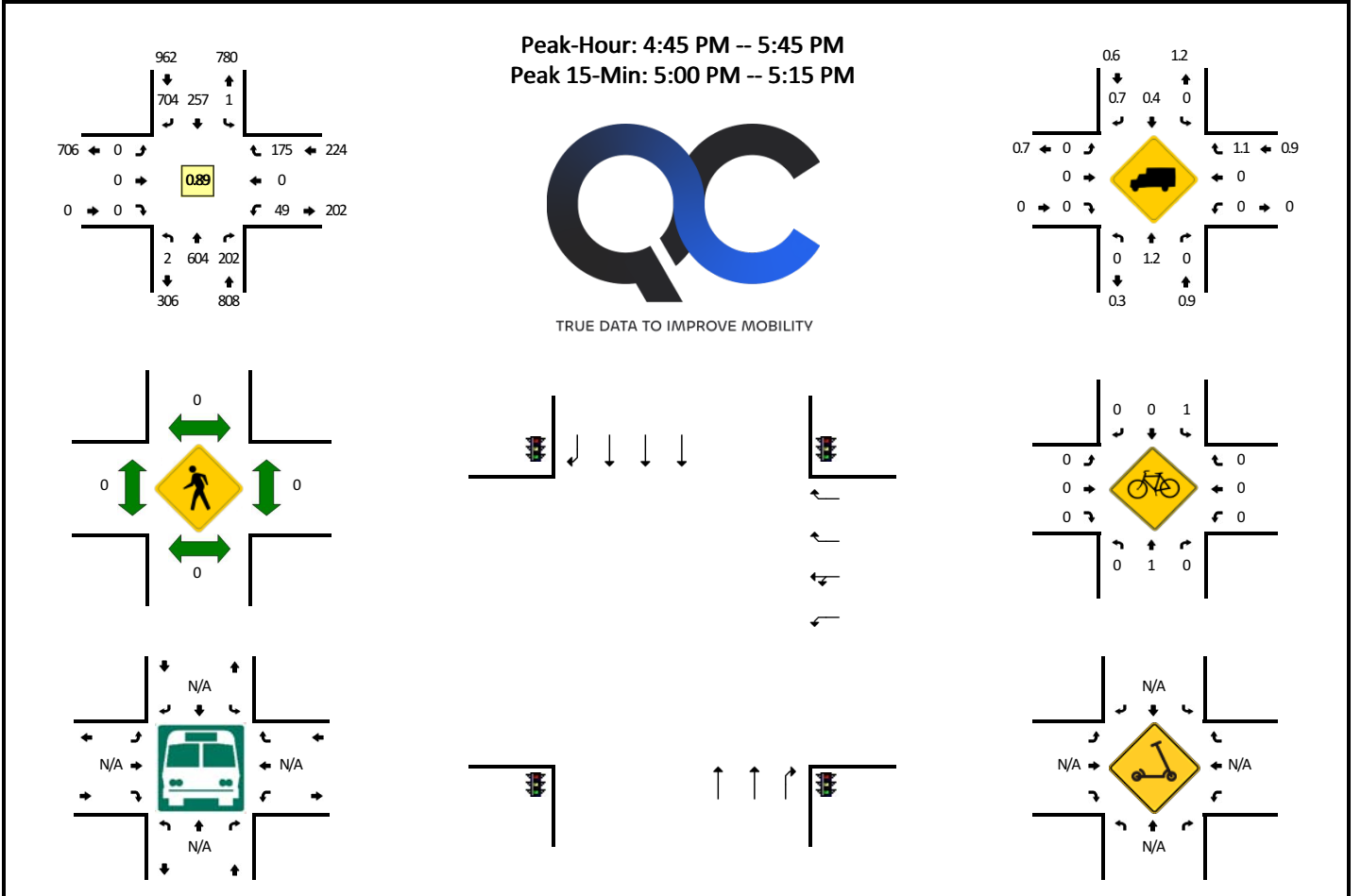

5-Min Count Period Beginning At	Airway Blvd (Northbound)				Airway Blvd (Southbound)				I-580 WB Ramps (Eastbound)				I-580 WB Ramps (Westbound)				Total	Hourly Totals
	Left	Thru	Right	U	Left	Thru	Right	U	Left	Thru	Right	U	Left	Thru	Right	U		
4:00 PM	0	55	15	0	0	34	55	0	0	0	0	0	1	0	13	0	173	
4:05 PM	1	43	15	0	0	21	80	0	0	0	0	0	3	0	8	0	171	
4:10 PM	0	40	15	0	0	18	57	0	0	0	0	0	6	0	25	0	161	
4:15 PM	0	48	10	0	0	14	41	0	0	0	0	0	1	0	14	0	128	
4:20 PM	0	59	15	0	0	10	53	0	0	0	0	0	2	0	15	0	154	
4:25 PM	0	52	20	0	0	15	54	0	0	0	0	0	1	0	17	0	159	
4:30 PM	0	39	16	0	0	18	50	1	0	0	0	0	1	0	15	0	140	
4:35 PM	1	46	14	0	0	28	42	0	0	0	0	0	1	0	16	0	148	
4:40 PM	0	60	15	0	0	17	67	0	0	0	0	0	3	0	15	0	177	
4:45 PM	1	51	15	0	0	18	43	0	0	0	0	0	2	0	16	0	146	
4:50 PM	0	55	8	0	0	25	55	0	0	0	0	0	6	0	13	0	162	
4:55 PM	0	54	19	0	0	24	44	0	0	0	0	0	3	0	12	0	156	1875
5:00 PM	0	52	22	0	0	22	76	0	0	0	0	0	2	0	15	0	189	1891
5:05 PM	0	56	23	0	0	23	77	0	0	0	0	0	4	0	14	0	197	1917
5:10 PM	0	47	20	0	0	23	66	0	0	0	0	0	3	0	15	0	174	1930
5:15 PM	0	42	15	0	0	19	59	0	0	0	0	0	7	0	16	0	158	1960
5:20 PM	0	39	16	0	0	15	66	0	0	0	0	0	3	0	13	0	152	1958
5:25 PM	0	49	15	0	0	15	57	0	0	0	0	0	5	0	12	0	153	1952
5:30 PM	1	47	18	0	0	19	36	1	0	0	0	0	3	0	13	0	138	1950
5:35 PM	0	54	21	0	0	25	63	0	0	0	0	0	5	0	15	0	183	1985
5:40 PM	0	58	10	0	0	29	62	0	0	0	0	0	6	0	21	0	186	1994
5:45 PM	0	55	12	0	0	29	36	0	0	0	0	0	0	0	10	0	142	1990
5:50 PM	0	61	18	0	0	19	46	0	0	0	0	0	8	0	12	0	164	1992
5:55 PM	0	49	8	0	0	14	56	0	0	0	0	0	2	0	10	0	139	1975
Peak 15-Min Flowrates	Northbound				Southbound				Eastbound				Westbound				Total	
	Left	Thru	Right	U	Left	Thru	Right	U	Left	Thru	Right	U	Left	Thru	Right	U		
All Vehicles	0	620	260	0	0	272	876	0	0	0	0	0	36	0	176	0	2240	
Heavy Trucks	0	4	0		0	4	8		0	0	0		0	0	4		20	
Buses																		
Pedestrians	0	0				0				0				0			0	
Bicycles					4	0	0			0	0	0		0	0		4	
Scoters																		

Comments:

**LOCATION:** Airway Blvd -- N Canyons Pkwy  
**CITY/STATE:** Livermore, CA

**QC JOB #:** 16444303  
**DATE:** Wed, Jan 10 2024

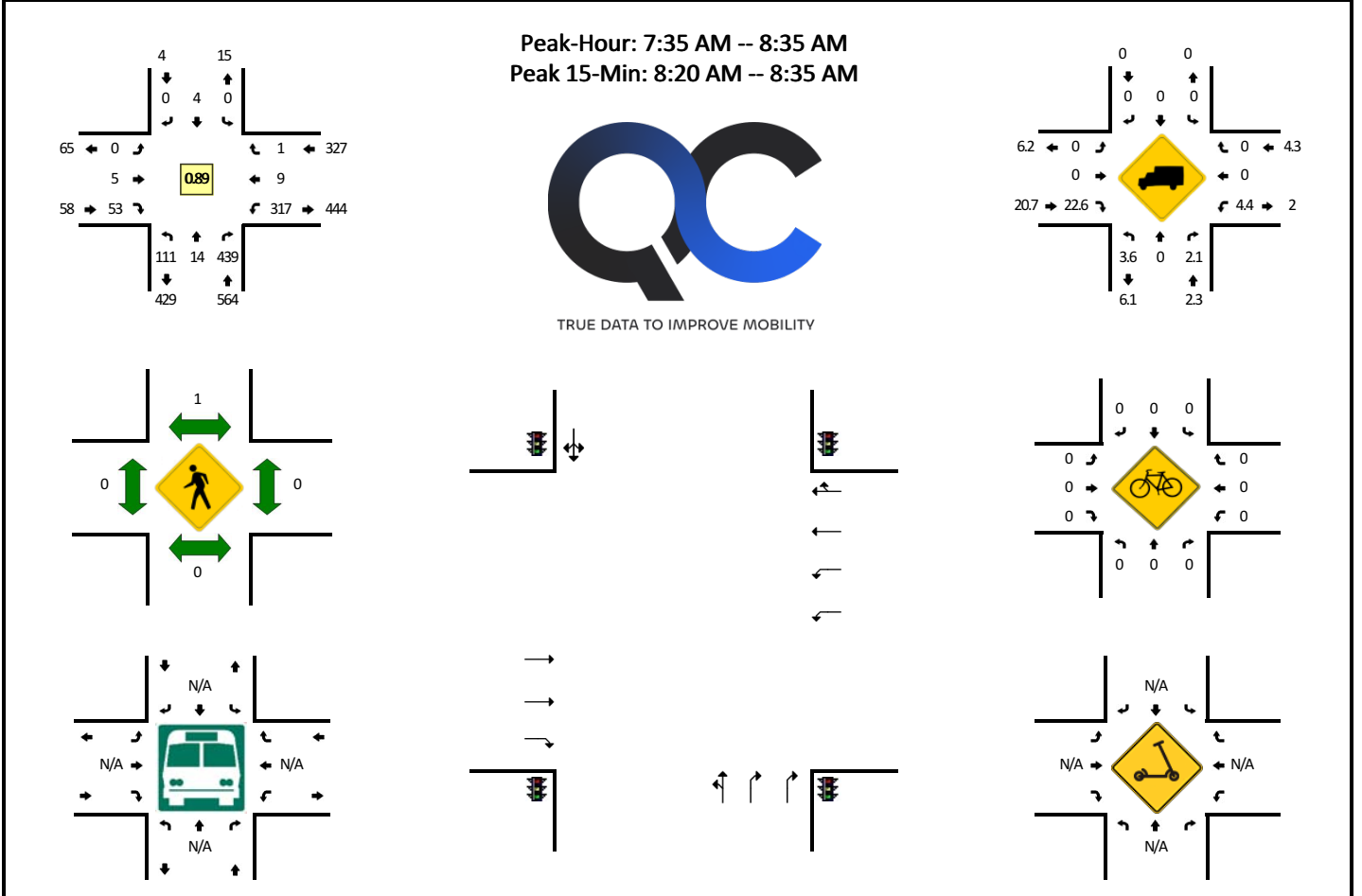

5-Min Count Period Beginning At	Airway Blvd (Northbound)				Airway Blvd (Southbound)				N Canyons Pkwy (Eastbound)				N Canyons Pkwy (Westbound)				Total	Hourly Totals
	Left	Thru	Right	U	Left	Thru	Right	U	Left	Thru	Right	U	Left	Thru	Right	U		
7:00 AM	2	0	8	6	0	0	0	0	0	0	3	0	20	0	0	0	39	
7:05 AM	3	0	19	3	0	0	0	0	0	1	6	0	21	0	0	0	53	
7:10 AM	4	1	21	4	0	0	0	0	0	0	2	0	12	0	0	0	44	
7:15 AM	4	0	20	6	0	0	0	0	0	0	2	0	24	0	0	0	56	
7:20 AM	9	1	27	3	0	0	0	0	0	1	1	0	31	2	0	0	75	
7:25 AM	6	0	33	5	0	0	0	0	0	1	6	0	27	1	0	0	79	
7:30 AM	5	0	29	4	0	0	0	0	0	0	6	0	24	1	0	0	69	
7:35 AM	4	0	33	3	0	0	0	0	0	0	5	0	30	0	0	0	75	
7:40 AM	5	0	38	7	0	0	0	0	0	0	4	0	21	1	0	0	76	
7:45 AM	1	3	37	9	0	1	0	0	0	0	5	0	34	1	0	0	91	
7:50 AM	6	2	42	6	0	0	0	0	0	0	5	0	25	1	0	0	87	
7:55 AM	5	0	39	3	0	1	0	0	0	0	6	0	28	2	0	0	84	828
8:00 AM	5	1	33	4	0	0	0	0	0	0	3	0	29	1	0	0	76	865
8:05 AM	11	0	22	1	0	0	0	0	0	0	3	0	26	0	1	0	64	876
8:10 AM	3	2	36	5	0	0	0	0	0	4	2	0	14	1	0	0	67	899
8:15 AM	5	1	36	5	0	0	0	0	0	0	0	0	19	0	0	0	66	909
8:20 AM	5	4	47	5	0	0	0	0	0	0	6	0	34	1	0	0	102	936
8:25 AM	4	0	32	4	0	1	0	0	0	0	8	0	35	1	0	0	85	942
8:30 AM	2	1	44	3	0	1	0	0	0	1	6	0	22	0	0	0	80	953
8:35 AM	5	2	28	4	0	0	0	0	0	0	0	0	19	0	0	0	58	936
8:40 AM	5	2	49	1	0	0	0	0	0	0	6	0	21	1	0	0	85	945
8:45 AM	2	1	40	2	0	0	0	0	0	1	0	0	27	0	0	0	73	927
8:50 AM	5	2	41	1	0	1	0	0	0	1	8	0	17	0	0	1	77	917
8:55 AM	3	0	60	5	1	0	0	0	0	1	0	0	28	1	2	0	101	934
Peak 15-Min Flowrates	Northbound				Southbound				Eastbound				Westbound				Total	
	Left	Thru	Right	U	Left	Thru	Right	U	Left	Thru	Right	U	Left	Thru	Right	U		
All Vehicles	44	20	492	48	0	8	0	0	0	4	80	0	364	8	0	0	1068	
Heavy Trucks	0	0	8		0	0	0		0	0	20		28	0	0		56	
Buses																		
Pedestrians	0	0			0	0			0	0			0	0			0	
Bicycles	0	0			0	0			0	0			0	0			0	
Scoters																		

Comments:

**LOCATION:** Airway Blvd -- N Canyons Pkwy  
**CITY/STATE:** Livermore, CA

**QC JOB #:** 16444304  
**DATE:** Wed, Jan 10 2024

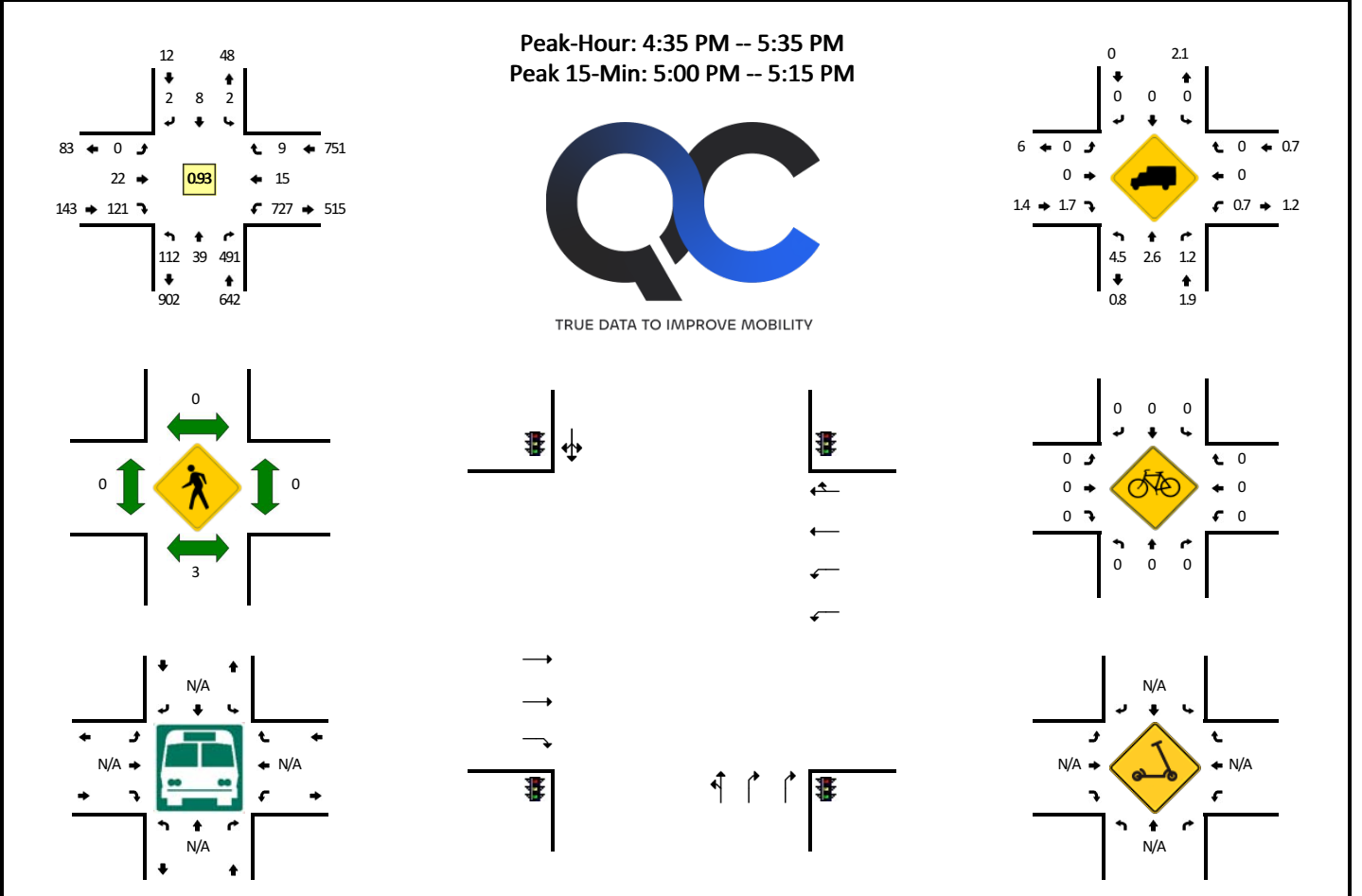

5-Min Count Period Beginning At	Airway Blvd (Northbound)				Airway Blvd (Southbound)				N Canyons Pkwy (Eastbound)				N Canyons Pkwy (Westbound)				Total	Hourly Totals
	Left	Thru	Right	U	Left	Thru	Right	U	Left	Thru	Right	U	Left	Thru	Right	U		
4:00 PM	4	1	61	4	0	0	0	0	0	2	9	0	54	1	0	0	136	
4:05 PM	11	2	45	2	1	2	0	0	0	2	13	0	54	0	0	0	132	
4:10 PM	4	1	47	8	0	0	0	0	0	0	14	0	52	0	0	0	126	
4:15 PM	5	3	47	6	0	2	0	0	0	0	12	0	58	2	1	0	136	
4:20 PM	3	2	50	2	1	0	0	0	0	1	8	0	60	1	0	0	128	
4:25 PM	3	1	40	5	0	0	0	0	0	1	7	0	49	0	0	0	106	
4:30 PM	0	1	37	5	0	0	0	0	0	2	8	0	46	0	0	0	99	
4:35 PM	1	1	46	4	0	0	0	0	0	2	9	0	70	2	0	0	135	
4:40 PM	9	4	47	5	0	0	0	0	0	5	8	0	53	1	1	0	133	
4:45 PM	4	5	31	3	0	0	0	0	0	3	7	0	62	1	0	0	116	
4:50 PM	7	9	39	4	0	0	0	0	0	1	16	0	39	1	1	0	117	
4:55 PM	4	6	34	3	0	0	0	0	0	3	13	0	55	1	1	0	120	1484
5:00 PM	4	3	44	0	0	0	0	0	0	1	8	0	63	2	0	0	125	1473
5:05 PM	4	2	52	5	1	0	0	0	0	1	15	0	71	1	0	0	152	1493
5:10 PM	2	3	39	0	0	0	0	0	0	1	6	0	84	2	1	0	138	1505
5:15 PM	6	1	38	6	0	1	2	0	0	1	8	0	58	1	1	0	123	1492
5:20 PM	8	2	45	6	1	3	0	0	0	2	9	0	62	2	1	0	141	1505
5:25 PM	5	2	46	8	0	2	0	0	0	0	8	0	62	0	2	0	135	1534
5:30 PM	12	1	30	2	0	2	0	0	0	2	14	0	48	1	1	0	113	1548
5:35 PM	11	1	46	3	0	3	0	0	0	2	15	0	51	0	1	0	133	1546
5:40 PM	2	3	41	4	0	1	0	0	0	0	10	0	49	1	0	0	111	1524
5:45 PM	7	6	30	5	0	1	0	0	0	3	5	0	48	1	1	0	107	1515
5:50 PM	1	2	35	10	0	0	0	0	0	2	12	0	45	1	1	0	109	1507
5:55 PM	7	6	36	4	0	0	0	0	0	1	6	0	57	0	0	0	117	1504
Peak 15-Min Flowrates	Northbound				Southbound				Eastbound				Westbound				Total	
	Left	Thru	Right	U	Left	Thru	Right	U	Left	Thru	Right	U	Left	Thru	Right	U		
All Vehicles	40	32	540	20	4	0	0	0	0	12	116	0	872	20	4	0	1660	
Heavy Trucks	0	0	8		0	0	0		0	0	4		4	0	0		16	
Buses																		
Pedestrians		4				0				0				0			4	
Bicycles	0	0	0		0	0	0		0	0	0		0	0	0		0	
Scoters																		

*Comments:*

**LOCATION:** Pino Grande Rd -- Central Pkwy  
**CITY/STATE:** Dublin, CA

**QC JOB #:** 16444307  
**DATE:** Wed, Jan 10 2024

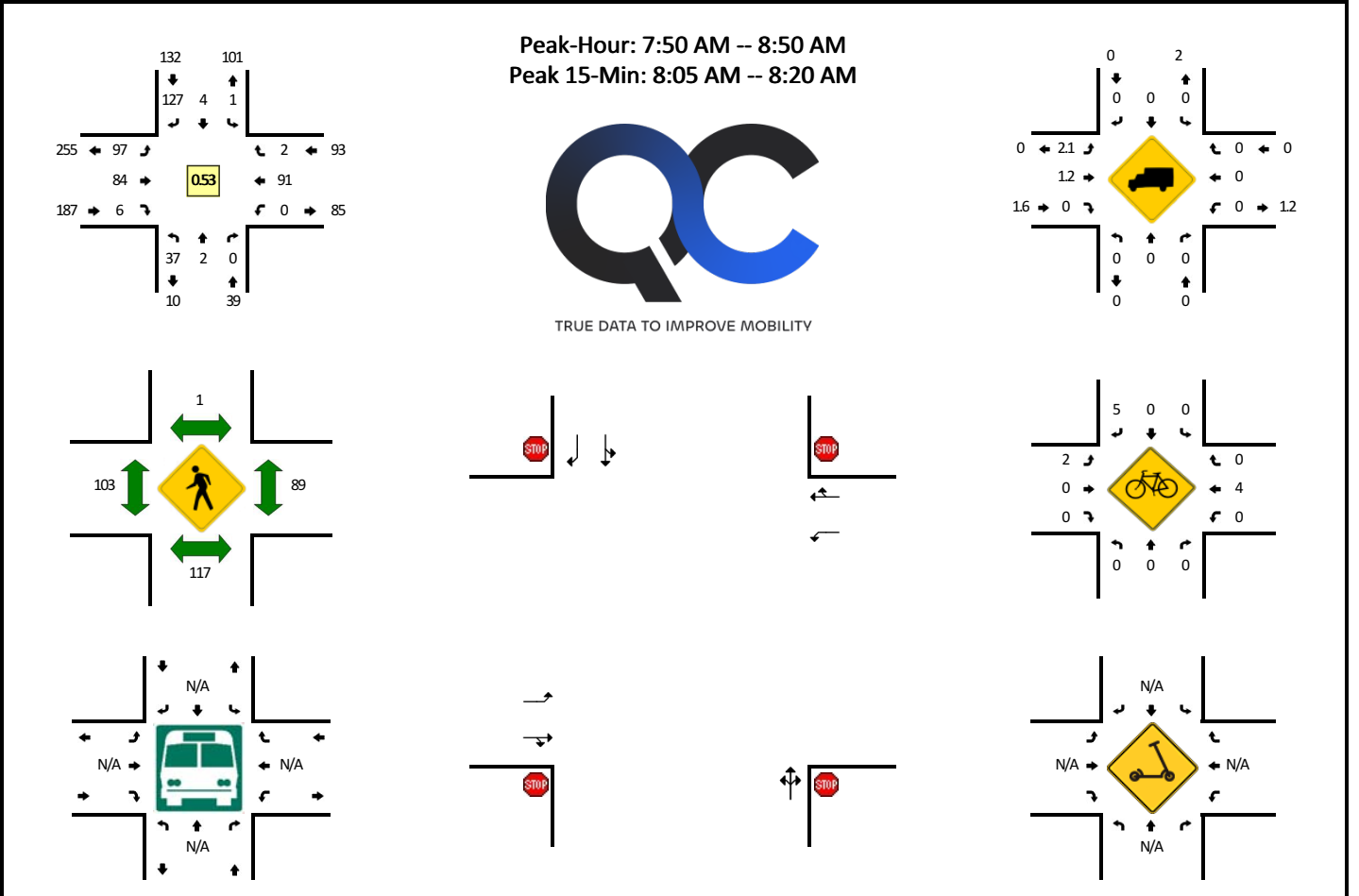

5-Min Count Period Beginning At	Pino Grande Rd (Northbound)				Pino Grande Rd (Southbound)				Central Pkwy (Eastbound)				Central Pkwy (Westbound)				Total	Hourly Totals	
	Left	Thru	Right	U	Left	Thru	Right	U	Left	Thru	Right	U	Left	Thru	Right	U			
7:00 AM	1	0	0	0	0	0	4	0	1	0	0	0	0	2	0	0	0	8	
7:05 AM	1	0	1	0	0	0	1	0	0	1	1	0	0	0	2	0	0	7	
7:10 AM	1	0	0	0	0	0	3	0	1	1	0	0	0	0	0	0	0	6	
7:15 AM	2	0	0	0	0	0	2	0	3	1	0	0	0	0	0	0	0	8	
7:20 AM	2	0	0	0	0	0	2	0	2	0	0	0	0	1	0	0	0	7	
7:25 AM	1	0	0	0	0	0	3	0	0	1	0	0	0	0	0	0	0	5	
7:30 AM	4	0	0	0	0	0	1	0	2	2	0	0	0	0	0	0	0	9	
7:35 AM	0	0	0	0	0	0	3	0	1	1	0	0	0	0	1	0	0	6	
7:40 AM	2	0	0	0	0	0	6	0	2	2	0	0	0	0	0	0	0	12	
7:45 AM	2	0	0	0	0	0	3	0	3	0	0	0	0	0	1	0	0	9	
7:50 AM	6	0	0	0	0	0	5	0	6	15	2	0	0	0	12	0	0	46	
7:55 AM	3	0	0	0	0	1	7	0	9	7	1	0	0	0	9	1	0	38	161
8:00 AM	2	1	0	0	0	1	18	0	13	11	1	0	0	0	10	0	0	57	210
8:05 AM	2	0	0	0	0	1	16	0	14	7	0	0	0	0	9	0	0	49	252
8:10 AM	5	0	0	0	1	0	24	0	22	24	2	0	0	0	19	0	0	97	343
8:15 AM	4	0	0	0	0	0	12	0	16	14	0	0	0	0	22	0	0	68	403
8:20 AM	3	0	0	0	0	0	8	0	1	0	0	0	0	0	1	0	0	13	409
8:25 AM	2	0	0	0	0	0	9	0	4	1	0	0	0	0	3	0	0	19	423
8:30 AM	4	0	0	0	0	0	8	0	5	0	0	0	0	0	0	0	0	17	431
8:35 AM	1	1	0	0	0	1	4	0	2	2	0	0	0	0	4	0	0	15	440
8:40 AM	2	0	0	0	0	0	8	0	3	2	0	0	0	0	2	1	0	18	446
8:45 AM	3	0	0	0	0	0	8	0	2	1	0	0	0	0	0	0	0	14	451
8:50 AM	1	0	0	0	0	0	8	0	3	5	2	0	0	0	4	0	0	23	428
8:55 AM	1	0	0	0	0	0	6	0	4	2	0	0	0	0	0	0	0	13	403
Peak 15-Min Flowrates	Northbound				Southbound				Eastbound				Westbound				Total		
	Left	Thru	Right	U	Left	Thru	Right	U	Left	Thru	Right	U	Left	Thru	Right	U			
All Vehicles	44	0	0	0	4	4	208	0	208	180	8	0	0	200	0	0	856		
Heavy Trucks	0	0	0	0	0	0	0	0	0	4	0	0	0	0	0	0	4		
Buses		180				0				188				140			508		
Pedestrians	0	0	0		0	0	4		8	0	0		0	12	0		24		
Bicycles																			
Scooters																			

Comments:

**LOCATION:** Pino Grande Rd -- Central Pkwy  
**CITY/STATE:** Dublin, CA

**QC JOB #:** 16444308  
**DATE:** Wed, Jan 10 2024

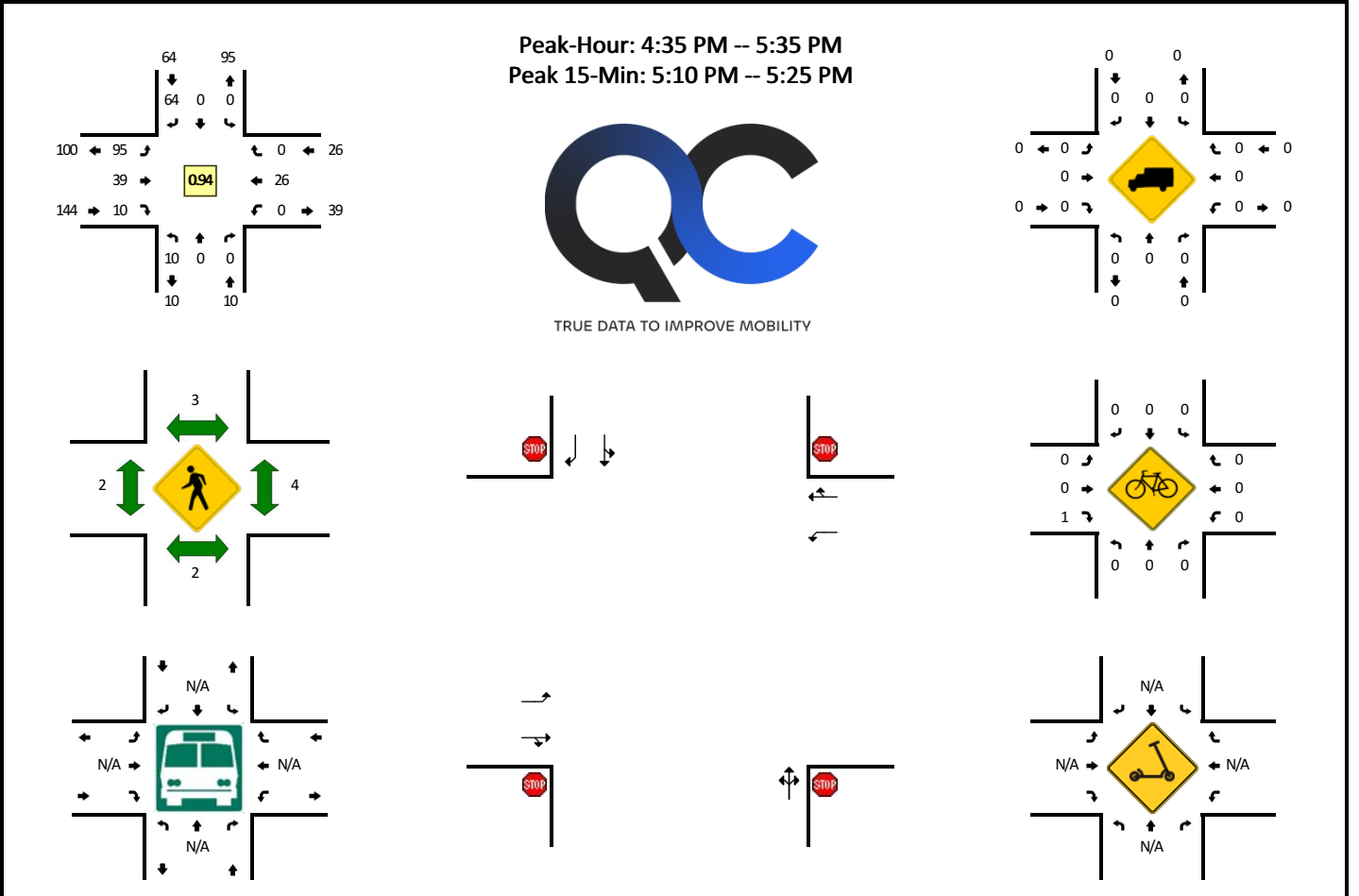

5-Min Count Period Beginning At	Pino Grande Rd (Northbound)				Pino Grande Rd (Southbound)				Central Pkwy (Eastbound)				Central Pkwy (Westbound)				Total	Hourly Totals
	Left	Thru	Right	U	Left	Thru	Right	U	Left	Thru	Right	U	Left	Thru	Right	U		
4:00 PM	2	0	0	0	0	0	2	0	4	1	2	0	0	0	0	0	11	
4:05 PM	1	0	1	0	0	0	2	0	7	3	1	0	0	1	1	0	17	
4:10 PM	0	0	0	0	0	0	5	0	6	1	0	0	0	0	0	0	12	
4:15 PM	0	0	0	0	1	0	6	0	1	2	1	0	0	3	0	0	14	
4:20 PM	0	0	0	0	0	0	4	0	4	1	1	0	0	1	0	0	11	
4:25 PM	1	0	0	0	0	0	1	0	5	0	2	0	0	3	0	0	12	
4:30 PM	1	0	0	0	0	0	8	0	3	2	1	0	0	0	0	0	15	
4:35 PM	0	0	0	0	0	0	6	0	7	5	0	0	0	2	0	0	20	
4:40 PM	0	0	0	0	0	0	7	0	7	2	0	0	0	2	0	0	18	
4:45 PM	1	0	0	0	0	0	5	0	10	2	1	0	0	4	0	0	23	
4:50 PM	1	0	0	0	0	0	6	0	7	4	1	0	0	1	0	0	20	
4:55 PM	1	0	0	0	0	0	5	0	7	3	1	0	0	2	0	0	19	192
5:00 PM	2	0	0	0	0	0	4	0	9	4	2	0	0	3	0	0	24	205
5:05 PM	2	0	0	0	0	0	7	0	7	1	2	0	0	0	0	0	19	207
5:10 PM	1	0	0	0	0	0	3	0	10	2	1	0	0	2	0	0	19	214
5:15 PM	1	0	0	0	0	0	7	0	6	4	0	0	0	1	0	0	19	219
5:20 PM	0	0	0	0	0	0	4	0	11	7	0	0	0	5	0	0	27	235
5:25 PM	0	0	0	0	0	0	5	0	9	3	0	0	0	2	0	0	19	242
5:30 PM	1	0	0	0	0	0	5	0	5	2	2	0	0	2	0	0	17	244
5:35 PM	1	0	0	0	0	0	3	0	3	2	1	0	0	0	0	0	10	234
5:40 PM	1	0	0	0	0	0	6	0	8	1	1	0	0	1	0	0	18	234
5:45 PM	3	0	0	0	0	0	4	0	14	3	1	0	0	2	1	0	28	239
5:50 PM	0	0	0	0	0	0	6	0	9	1	1	0	1	1	1	0	20	239
5:55 PM	2	0	0	0	0	0	3	0	8	3	1	0	0	1	0	0	18	238
Peak 15-Min Flowrates	Northbound				Southbound				Eastbound				Westbound				Total	
	Left	Thru	Right	U	Left	Thru	Right	U	Left	Thru	Right	U	Left	Thru	Right	U		
All Vehicles	8	0	0	0	0	0	56	0	108	52	4	0	0	32	0	0	260	
Heavy Trucks	0	0	0	0	0	0	0	0	0	0	0	0	0	0	0	0	0	
Buses																		
Pedestrians		4				0				8				0			12	
Bicycles	0	0	0		0	0	0		0	0	0		0	0	0		0	
Scoters																		

Comments:

**LOCATION:** Fallon Rd -- Central Pkwy  
**CITY/STATE:** Dublin, CA

**QC JOB #:** 16444309  
**DATE:** Thu, Jan 18 2024

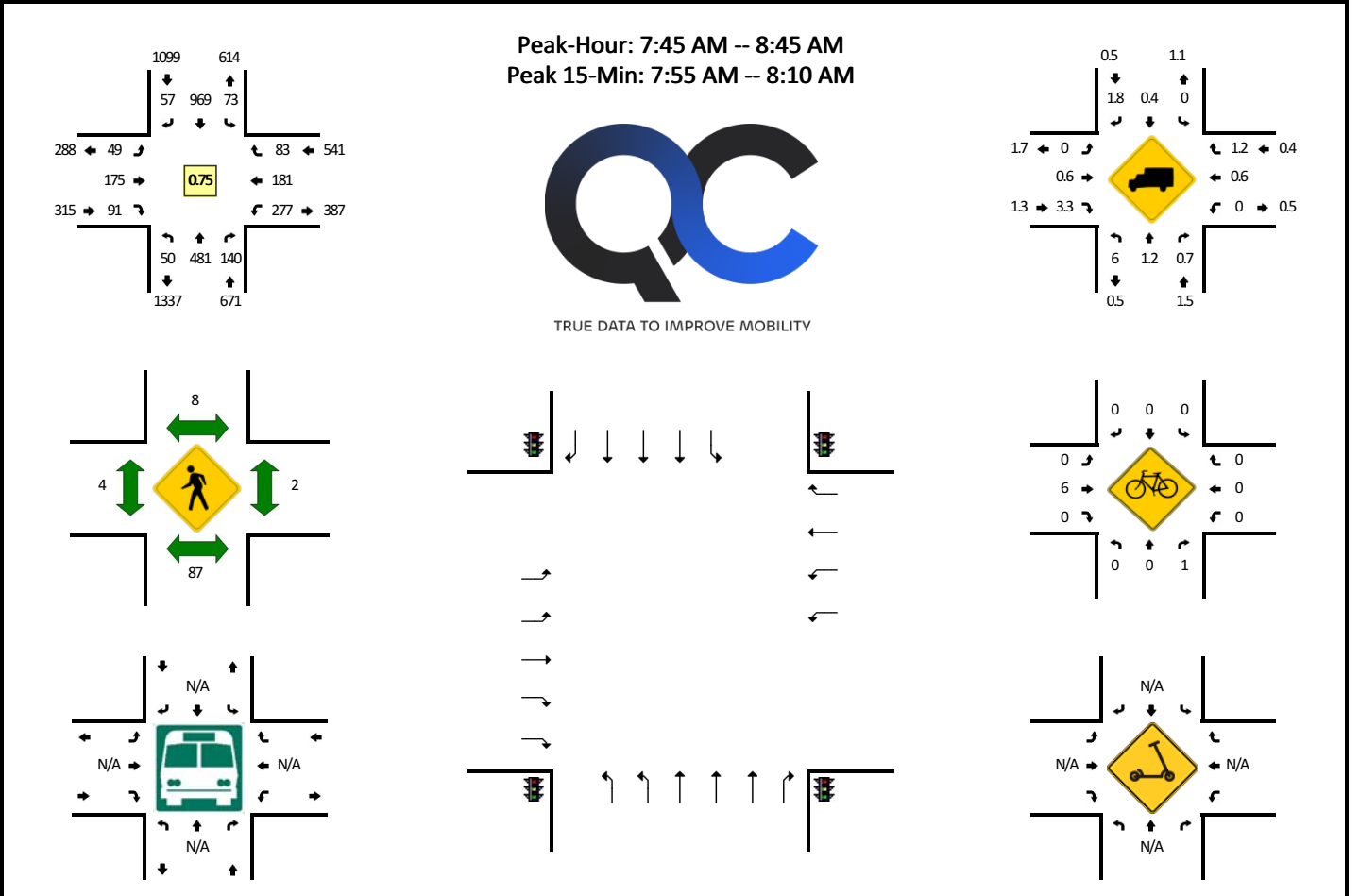

5-Min Count Period Beginning At	Fallon Rd (Northbound)				Fallon Rd (Southbound)				Central Pkwy (Eastbound)				Central Pkwy (Westbound)				Total	Hourly Totals
	Left	Thru	Right	U	Left	Thru	Right	U	Left	Thru	Right	U	Left	Thru	Right	U		
7:00 AM	5	18	7	0	0	38	0	0	0	4	2	0	10	0	0	0	84	
7:05 AM	0	14	3	1	1	32	1	0	1	1	2	0	5	1	0	0	62	
7:10 AM	0	14	6	0	6	31	0	0	0	12	4	0	4	5	4	0	86	
7:15 AM	5	26	2	0	9	10	2	0	0	4	8	0	17	8	7	0	98	
7:20 AM	2	24	5	0	0	45	0	0	1	0	2	0	13	2	3	0	97	
7:25 AM	2	31	9	0	2	28	1	0	1	2	7	0	11	0	0	0	94	
7:30 AM	1	31	5	0	4	44	2	0	0	4	2	0	16	0	1	0	110	
7:35 AM	3	31	9	0	3	43	2	0	3	3	3	0	10	1	2	0	113	
7:40 AM	3	35	13	0	3	67	3	0	2	1	9	0	13	2	1	0	152	
7:45 AM	3	36	12	0	4	80	5	0	4	9	6	0	19	1	4	0	183	
7:50 AM	3	27	16	0	2	80	5	1	5	36	9	0	16	17	4	0	221	
7:55 AM	2	52	23	0	25	112	3	0	3	38	12	0	26	21	5	0	322	1622
8:00 AM	3	30	22	0	16	80	1	0	1	50	5	0	31	33	15	0	287	1825
8:05 AM	5	31	15	0	10	96	3	0	2	25	6	0	30	29	13	0	265	2028
8:10 AM	6	25	9	0	5	68	7	0	4	5	9	0	28	25	10	0	201	2143
8:15 AM	0	48	5	0	3	80	3	0	7	2	12	0	41	38	16	0	255	2300
8:20 AM	3	28	5	0	0	68	7	0	3	0	10	0	24	7	6	0	161	2364
8:25 AM	3	43	6	0	4	81	6	0	8	2	6	0	10	6	2	0	177	2447
8:30 AM	8	50	10	0	1	74	5	0	5	4	3	0	11	1	2	0	174	2511
8:35 AM	8	52	8	0	2	89	9	0	2	3	11	0	16	2	2	0	204	2602
8:40 AM	6	59	9	0	0	61	3	0	5	1	2	0	25	1	4	0	176	2626
8:45 AM	3	45	13	0	1	43	6	0	11	1	4	0	15	2	4	0	148	2591
8:50 AM	3	42	10	0	2	58	7	0	3	6	3	0	10	2	0	0	146	2516
8:55 AM	5	27	11	0	0	39	4	0	5	2	4	0	14	1	4	0	116	2310
Peak 15-Min Flowrates	Northbound				Southbound				Eastbound				Westbound				Total	
	Left	Thru	Right	U	Left	Thru	Right	U	Left	Thru	Right	U	Left	Thru	Right	U		
All Vehicles	40	452	240	0	204	1152	28	0	24	452	92	0	348	332	132	0	3496	
Heavy Trucks	0	0	0		0	4	0		0	0	0		0	0	0		4	
Buses																		
Pedestrians		224				4				0				4			232	
Bicycles		0	4			0	0			24	0			0	0		28	
Scoters																		

Comments:

**LOCATION:** Fallon Rd -- Central Pkwy  
**CITY/STATE:** Dublin, CA

**QC JOB #:** 16444310  
**DATE:** Thu, Jan 18 2024

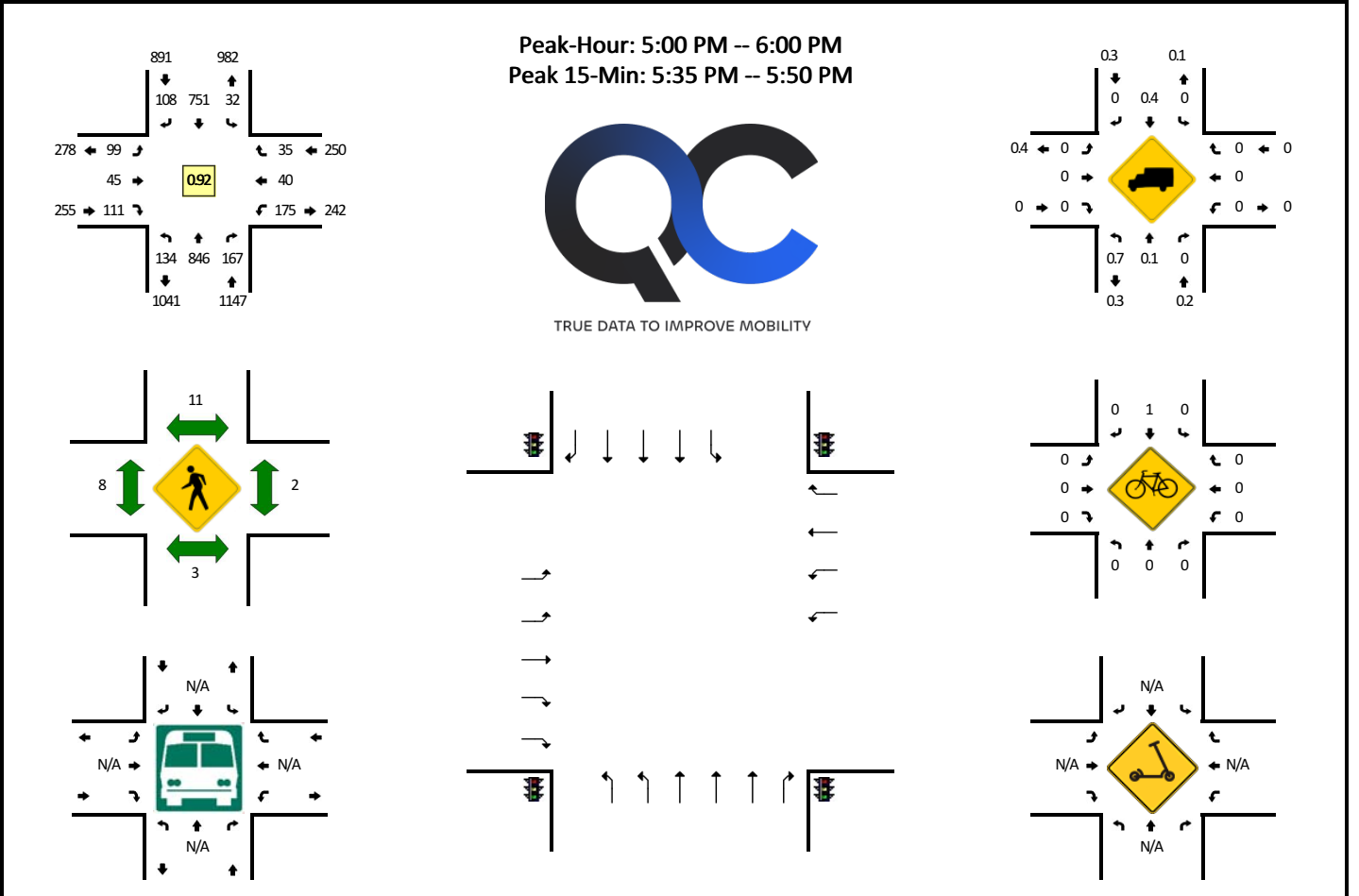

5-Min Count Period Beginning At	Fallon Rd (Northbound)				Fallon Rd (Southbound)				Central Pkwy (Eastbound)				Central Pkwy (Westbound)				Total	Hourly Totals
	Left	Thru	Right	U	Left	Thru	Right	U	Left	Thru	Right	U	Left	Thru	Right	U		
4:00 PM	7	58	8	0	2	48	6	0	5	0	5	0	15	1	2	0	157	
4:05 PM	2	48	17	0	3	67	7	0	2	3	9	0	16	3	2	1	180	
4:10 PM	12	76	10	0	3	57	8	0	2	3	3	0	10	5	4	0	193	
4:15 PM	5	59	16	2	1	66	4	0	5	3	6	0	11	1	1	0	180	
4:20 PM	5	63	15	0	1	50	7	0	3	4	7	0	10	2	1	0	168	
4:25 PM	6	70	12	1	3	42	10	1	8	5	5	0	15	2	0	0	180	
4:30 PM	4	45	14	0	2	47	6	0	8	4	11	0	11	3	2	0	157	
4:35 PM	3	60	16	0	2	68	5	0	10	2	9	0	19	3	5	0	202	
4:40 PM	5	48	11	0	2	66	5	0	6	9	6	0	13	1	1	0	173	
4:45 PM	7	72	15	0	2	43	10	0	4	3	3	0	11	5	1	0	176	
4:50 PM	3	74	10	0	0	65	8	0	3	3	6	0	15	3	2	0	192	
4:55 PM	2	59	11	0	1	52	6	0	10	4	5	0	12	3	2	0	167	2125
5:00 PM	11	63	5	0	2	60	4	0	4	2	8	0	8	1	1	0	169	2137
5:05 PM	9	66	15	0	3	35	8	0	6	3	4	0	16	1	2	0	168	2125
5:10 PM	10	54	10	0	1	79	9	0	7	5	9	0	15	1	6	0	206	2138
5:15 PM	8	76	16	0	0	62	8	1	11	7	5	0	19	7	1	0	221	2179
5:20 PM	9	61	18	1	3	52	6	0	10	3	7	0	15	7	2	0	194	2205
5:25 PM	10	79	7	0	4	64	14	0	5	4	10	0	14	6	5	0	222	2247
5:30 PM	11	94	15	1	3	53	9	0	8	2	9	0	10	1	4	0	220	2310
5:35 PM	6	79	17	0	3	80	12	0	10	2	7	0	18	4	3	0	241	2349
5:40 PM	15	65	11	1	2	64	13	0	8	3	14	0	20	4	2	0	222	2398
5:45 PM	15	56	16	0	4	87	8	0	8	3	15	0	12	3	4	0	231	2453
5:50 PM	10	57	23	1	2	50	7	1	8	6	18	0	15	4	2	0	204	2465
5:55 PM	16	96	14	0	3	65	10	0	14	5	5	0	13	1	3	0	245	2543
Peak 15-Min Flowrates	Northbound				Southbound				Eastbound				Westbound				Total	
	Left	Thru	Right	U	Left	Thru	Right	U	Left	Thru	Right	U	Left	Thru	Right	U		
All Vehicles	144	800	176	4	36	924	132	0	104	32	144	0	200	44	36	0	2776	
Heavy Trucks	0	0	0		0	0	0		0	0	0		0	0	0		0	
Buses																		
Pedestrians		12				4				0				8			24	
Bicycles	0	0	0		0	0	0		0	0	0		0	0	0		0	
Scoters																		

*Comments:*



**LOCATION:** Fallon Rd -- Dublin Blvd  
**CITY/STATE:** Dublin, CA

**QC JOB #:** 16444311  
**DATE:** Thu, Jan 18 2024

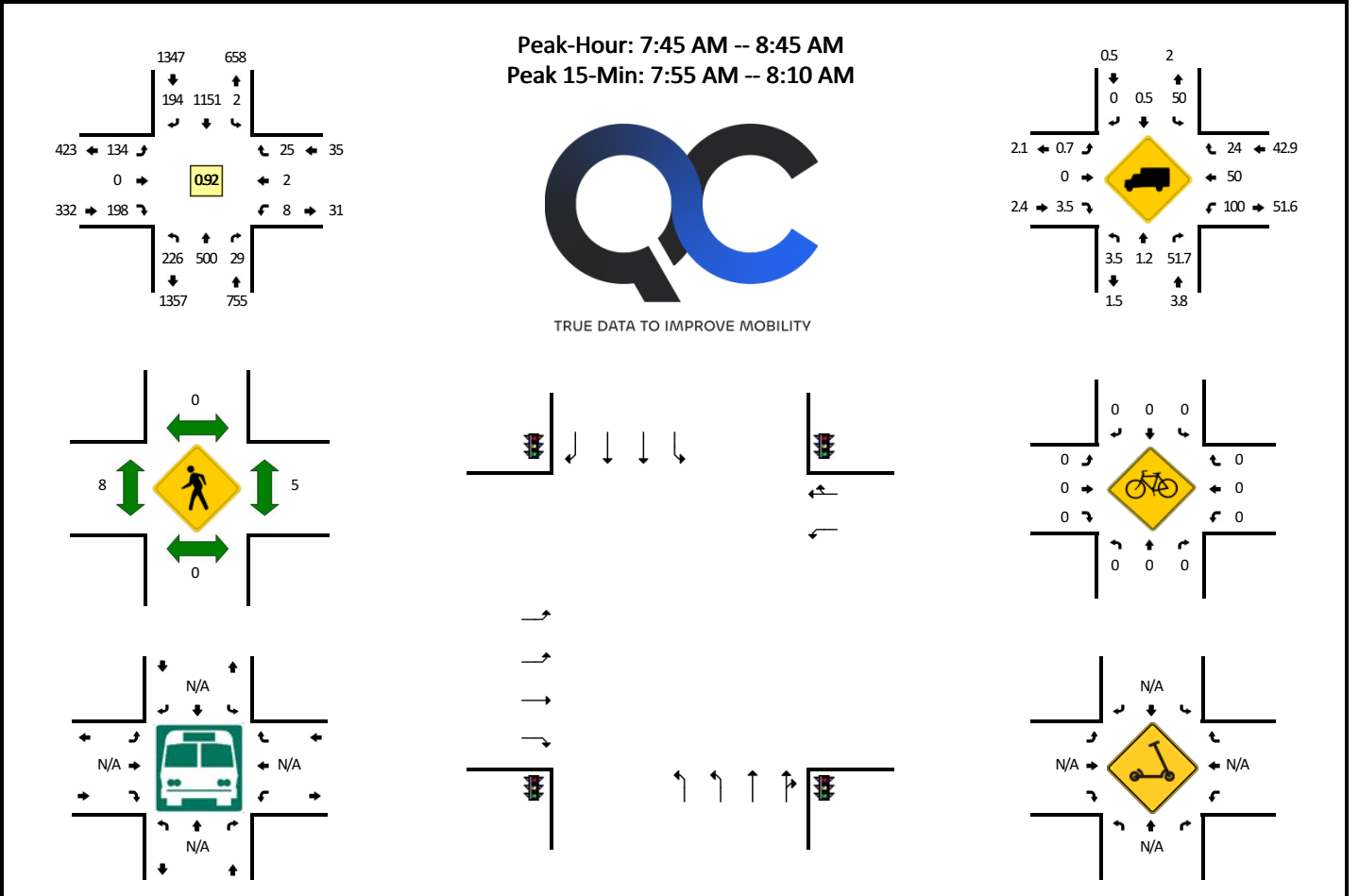

5-Min Count Period Beginning At	Fallon Rd (Northbound)				Fallon Rd (Southbound)				Dublin Blvd (Eastbound)				Dublin Blvd (Westbound)				Total	Hourly Totals
	Left	Thru	Right	U	Left	Thru	Right	U	Left	Thru	Right	U	Left	Thru	Right	U		
7:00 AM	10	28	0	0	0	49	4	0	3	0	8	0	0	0	0	0	102	
7:05 AM	10	14	0	0	0	32	9	0	3	0	10	0	0	0	0	0	78	
7:10 AM	6	16	0	0	0	28	3	0	2	0	11	0	0	0	1	0	67	
7:15 AM	16	31	1	0	0	42	5	0	5	0	7	0	0	0	3	0	110	
7:20 AM	15	26	1	0	0	48	6	0	2	0	6	0	0	0	2	0	106	
7:25 AM	8	30	1	0	0	48	2	0	8	0	8	0	0	0	5	0	110	
7:30 AM	13	28	1	0	0	55	5	0	4	0	19	0	0	0	3	0	128	
7:35 AM	11	38	1	0	0	50	7	0	5	0	9	0	0	0	2	0	123	
7:40 AM	8	36	1	0	0	62	8	0	7	0	16	0	0	0	5	0	143	
7:45 AM	16	44	1	0	0	75	21	0	5	0	15	0	0	0	0	0	177	
7:50 AM	24	33	2	0	1	87	10	0	12	0	17	0	0	0	2	0	188	
7:55 AM	8	42	3	0	0	121	23	0	28	0	18	0	1	0	0	0	244	1576
8:00 AM	16	38	6	0	0	135	21	0	7	0	7	0	0	0	3	0	233	1707
8:05 AM	21	32	0	0	0	85	16	0	19	0	22	0	0	0	1	0	196	1825
8:10 AM	19	32	2	0	0	121	19	0	10	0	16	0	2	1	5	0	227	1985
8:15 AM	20	30	1	0	0	98	20	0	13	0	20	0	1	0	2	0	205	2080
8:20 AM	28	34	2	0	0	101	12	0	7	0	19	0	2	0	2	0	207	2181
8:25 AM	24	45	2	0	0	77	16	0	4	0	21	0	0	0	1	0	190	2261
8:30 AM	12	54	3	0	0	84	13	0	7	0	8	0	0	0	2	0	183	2316
8:35 AM	17	48	2	0	1	82	12	0	13	0	20	0	0	0	1	0	196	2389
8:40 AM	21	68	5	0	0	85	11	0	8	0	15	1	2	1	6	0	223	2469
8:45 AM	28	44	0	0	0	68	5	0	7	0	13	0	1	0	1	0	167	2459
8:50 AM	22	38	0	0	0	56	8	0	12	0	11	0	0	0	3	0	150	2421
8:55 AM	13	27	2	0	0	64	5	0	10	0	21	0	0	0	1	0	143	2320
Peak 15-Min Flowrates	Northbound				Southbound				Eastbound				Westbound				Total	
	Left	Thru	Right	U	Left	Thru	Right	U	Left	Thru	Right	U	Left	Thru	Right	U		
All Vehicles	180	448	36	0	0	1364	240	0	216	0	188	0	4	0	16	0	2692	
Heavy Trucks	8	0	12		0	8	0		0	0	4		4	0	0		36	
Buses																		
Pedestrians	0	0			0	0			0	4			0	8			12	
Bicycles					0	0			0	0	0		0	0	0		0	
Scoters																		

Comments:

**LOCATION:** Fallon Rd -- Dublin Blvd  
**CITY/STATE:** Dublin, CA

**QC JOB #:** 16444312  
**DATE:** Thu, Jan 18 2024

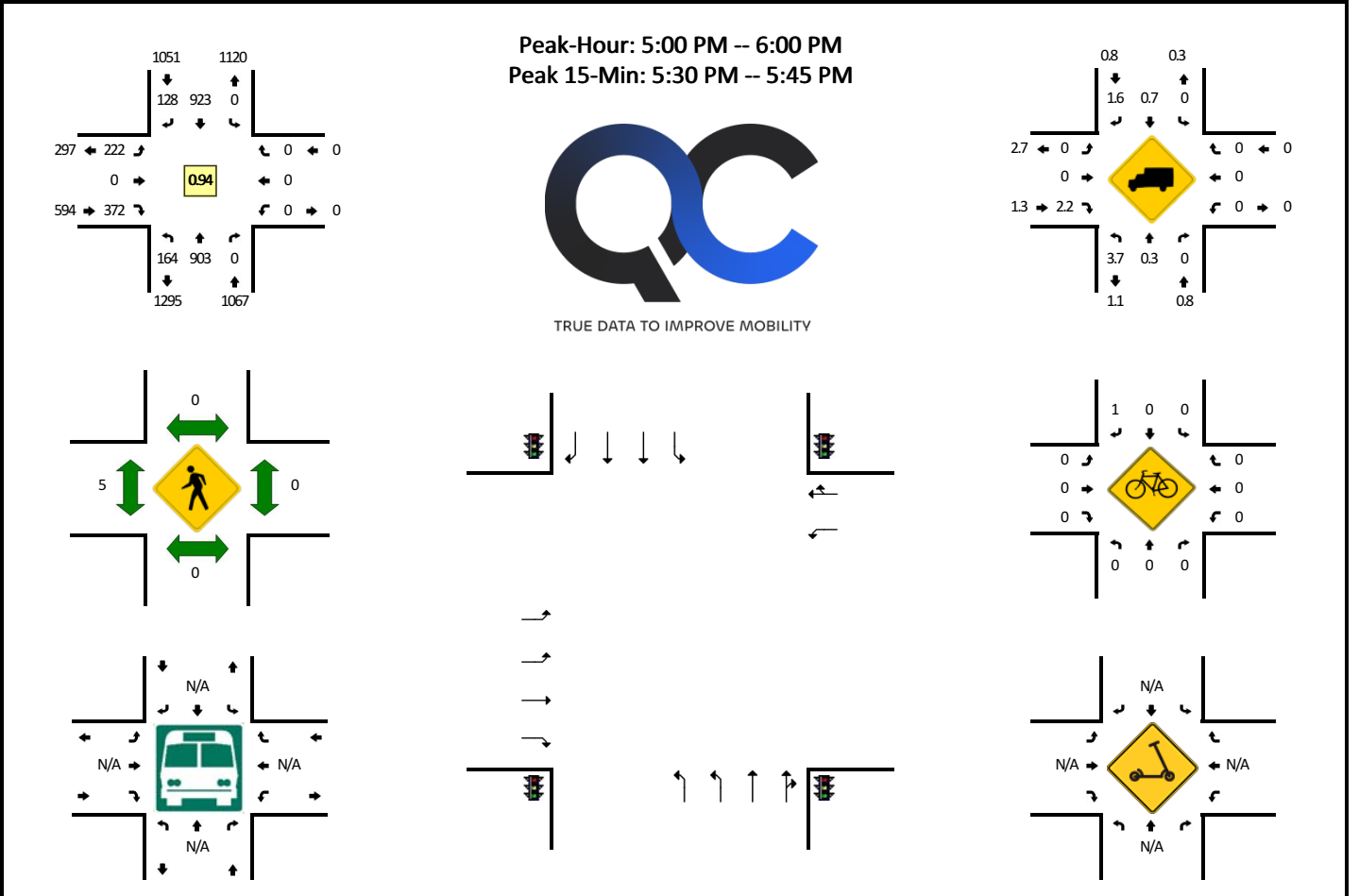

5-Min Count Period Beginning At	Fallon Rd (Northbound)				Fallon Rd (Southbound)				Dublin Blvd (Eastbound)				Dublin Blvd (Westbound)				Total	Hourly Totals
	Left	Thru	Right	U	Left	Thru	Right	U	Left	Thru	Right	U	Left	Thru	Right	U		
4:00 PM	14	53	0	0	0	49	13	0	12	0	24	0	0	0	0	0	165	
4:05 PM	15	67	0	0	0	83	12	0	13	0	28	0	0	0	0	0	218	
4:10 PM	15	66	0	0	0	58	5	0	19	0	39	0	0	0	0	0	202	
4:15 PM	24	75	0	0	0	67	5	0	9	0	31	0	0	0	0	0	211	
4:20 PM	10	76	0	0	0	76	11	0	16	0	29	0	0	0	0	0	218	
4:25 PM	14	66	0	0	0	55	11	0	23	0	35	0	0	0	0	0	204	
4:30 PM	11	42	0	0	0	59	8	0	18	0	27	0	0	0	0	0	165	
4:35 PM	13	58	0	0	0	78	9	0	15	0	34	0	0	0	0	0	207	
4:40 PM	12	54	0	0	0	75	15	0	10	0	37	0	0	0	0	0	203	
4:45 PM	7	65	0	0	0	54	12	0	22	0	33	1	0	0	0	0	194	
4:50 PM	16	67	0	0	0	78	9	0	15	0	21	0	0	0	0	0	206	
4:55 PM	11	63	0	0	0	62	7	0	19	0	35	1	0	0	0	0	198	2391
5:00 PM	13	74	0	0	0	56	7	0	12	0	40	0	0	0	0	0	202	2428
5:05 PM	12	53	0	0	0	69	4	0	18	0	36	1	0	0	0	0	193	2403
5:10 PM	13	77	0	0	0	56	12	0	19	0	42	0	0	0	0	0	219	2420
5:15 PM	14	71	0	0	0	103	11	0	14	0	30	0	0	0	0	0	243	2452
5:20 PM	16	68	0	0	0	65	10	0	20	0	38	1	0	0	0	0	218	2452
5:25 PM	14	83	0	0	0	73	19	0	18	0	24	0	0	0	0	0	231	2479
5:30 PM	17	82	0	0	0	57	13	0	21	0	42	1	0	0	0	0	233	2547
5:35 PM	10	95	0	0	0	83	13	0	19	0	22	0	0	0	0	0	242	2582
5:40 PM	25	68	0	0	0	98	10	0	14	0	28	0	0	0	0	0	243	2622
5:45 PM	6	59	0	0	0	100	8	0	23	0	28	1	0	0	0	0	225	2653
5:50 PM	11	78	0	0	0	90	12	0	21	0	23	1	0	0	0	0	236	2683
5:55 PM	13	95	0	0	0	73	9	0	18	0	19	0	0	0	0	0	227	2712
Peak 15-Min Flowrates	Northbound				Southbound				Eastbound				Westbound				Total	
	Left	Thru	Right	U	Left	Thru	Right	U	Left	Thru	Right	U	Left	Thru	Right	U		
All Vehicles	208	980	0	0	0	952	144	0	216	0	368	4	0	0	0	0	2872	
Heavy Trucks	12	0	0	0	0	0	0	0	0	0	16	0	0	0	0	0	28	
Buses																		
Pedestrians	0	0	0	0	0	0	0	0	0	4	0	0	0	0	0	0	4	
Bicycles	0	0	0	0	0	0	0	0	0	0	0	0	0	0	0	0	0	
Scooters																		

*Comments:*

**LOCATION:** Fallon Rd -- Fallon Gateway  
**CITY/STATE:** Dublin, CA

**QC JOB #:** 16444313  
**DATE:** Wed, Jan 10 2024

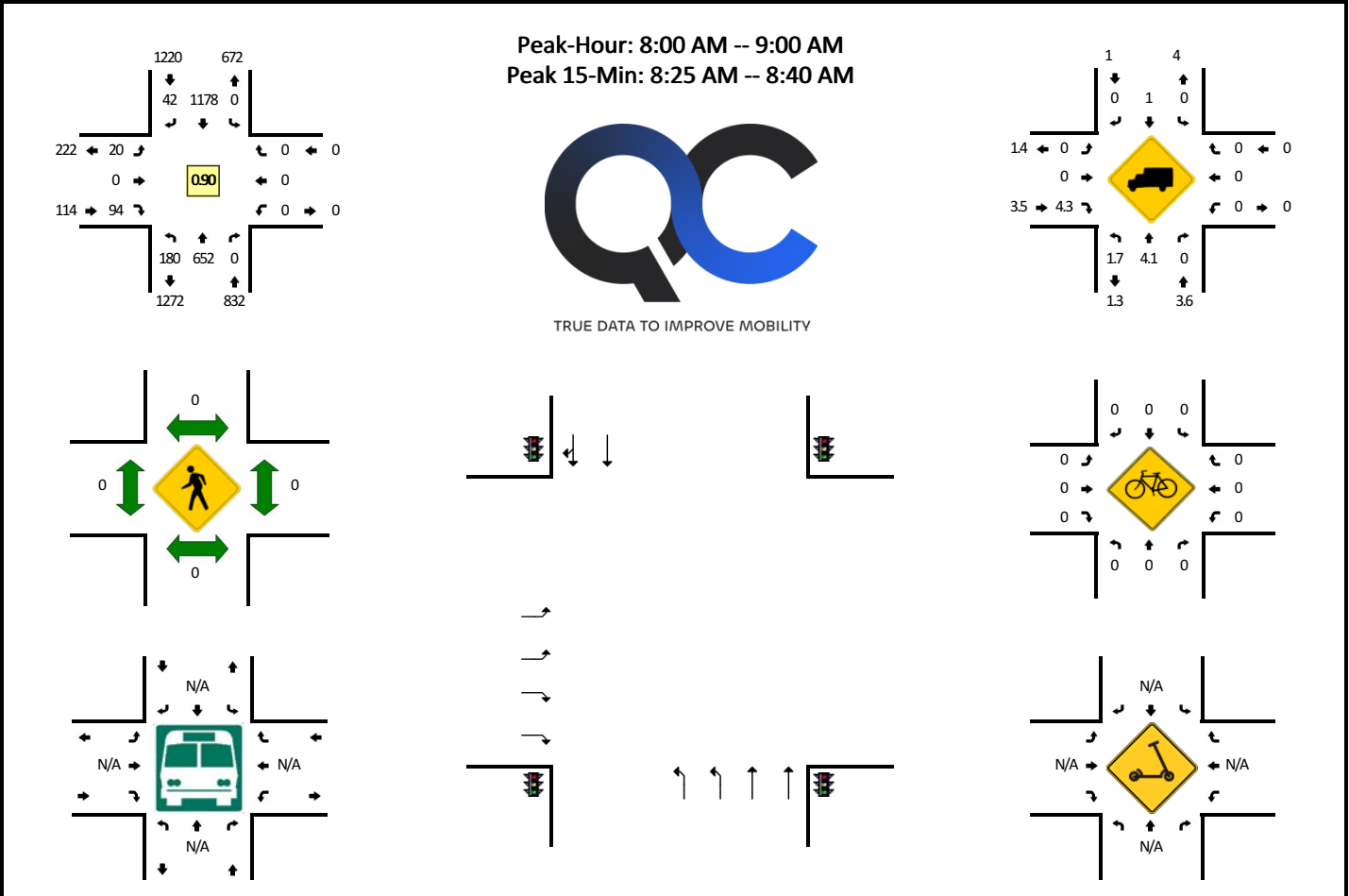

5-Min Count Period Beginning At	Fallon Rd (Northbound)				Fallon Rd (Southbound)				Fallon Gateway (Eastbound)				Fallon Gateway (Westbound)				Total	Hourly Totals
	Left	Thru	Right	U	Left	Thru	Right	U	Left	Thru	Right	U	Left	Thru	Right	U		
7:00 AM	12	23	0	0	0	30	0	0	0	0	0	0	0	0	0	0	65	
7:05 AM	10	27	0	0	0	40	2	0	0	1	0	4	0	0	0	0	84	
7:10 AM	8	29	0	0	0	40	4	0	0	0	0	9	0	0	0	0	90	
7:15 AM	5	45	0	0	0	46	3	0	0	1	0	2	0	0	0	0	102	
7:20 AM	10	46	0	0	0	42	0	0	0	2	0	4	0	0	0	0	104	
7:25 AM	3	38	0	0	0	50	2	0	0	0	0	3	0	0	0	0	96	
7:30 AM	16	34	0	0	0	52	1	0	0	0	0	2	0	0	0	0	105	
7:35 AM	8	61	0	0	0	80	5	0	0	0	0	3	0	0	0	0	157	
7:40 AM	10	46	0	0	0	70	2	0	0	1	0	1	0	0	0	0	130	
7:45 AM	14	54	0	0	0	72	2	0	0	2	0	4	0	0	0	0	148	
7:50 AM	11	72	0	0	0	74	3	0	0	1	0	9	0	0	0	0	170	
7:55 AM	18	43	0	0	0	99	1	0	0	1	0	7	0	0	0	0	169	1420
8:00 AM	17	49	0	0	0	64	3	0	0	2	0	2	0	0	0	0	137	1492
8:05 AM	7	56	0	0	0	102	2	0	0	0	0	7	0	0	0	0	174	1582
8:10 AM	14	44	0	0	0	85	3	0	0	1	0	6	0	0	0	0	153	1645
8:15 AM	12	46	0	0	0	133	6	0	0	3	0	11	0	0	0	0	211	1754
8:20 AM	9	50	0	0	0	120	2	0	0	1	0	6	0	0	0	0	188	1838
8:25 AM	17	46	0	0	0	122	7	0	0	2	0	6	0	0	0	0	200	1942
8:30 AM	17	51	0	0	0	113	7	0	0	0	0	11	0	0	0	0	199	2036
8:35 AM	11	56	0	0	0	122	3	0	0	2	0	7	0	0	0	0	201	2080
8:40 AM	23	53	0	0	0	92	3	0	0	3	0	15	0	0	0	0	189	2139
8:45 AM	15	63	0	0	0	82	2	0	0	4	0	7	0	0	0	0	173	2164
8:50 AM	14	65	0	0	0	77	3	0	0	0	0	11	0	0	0	0	170	2164
8:55 AM	24	73	0	0	0	66	1	0	0	2	0	5	0	0	0	0	171	2166
Peak 15-Min Flowrates	Northbound				Southbound				Eastbound				Westbound				Total	
	Left	Thru	Right	U	Left	Thru	Right	U	Left	Thru	Right	U	Left	Thru	Right	U		
All Vehicles	180	612	0	0	0	1428	68	0	0	16	0	96	0	0	0	0	0	2400
Heavy Trucks	4	32	0	0	0	16	0	0	0	0	0	0	0	0	0	0	0	52
Buses	0	0	0	0	0	0	0	0	0	0	0	0	0	0	0	0	0	0
Pedestrians	0	0	0	0	0	0	0	0	0	0	0	0	0	0	0	0	0	0
Bicycles	0	0	0	0	0	0	0	0	0	0	0	0	0	0	0	0	0	0
Scoters	0	0	0	0	0	0	0	0	0	0	0	0	0	0	0	0	0	0

Comments:

**LOCATION:** Fallon Rd -- Fallon Gateway  
**CITY/STATE:** Dublin, CA

**QC JOB #:** 16444314  
**DATE:** Wed, Jan 10 2024

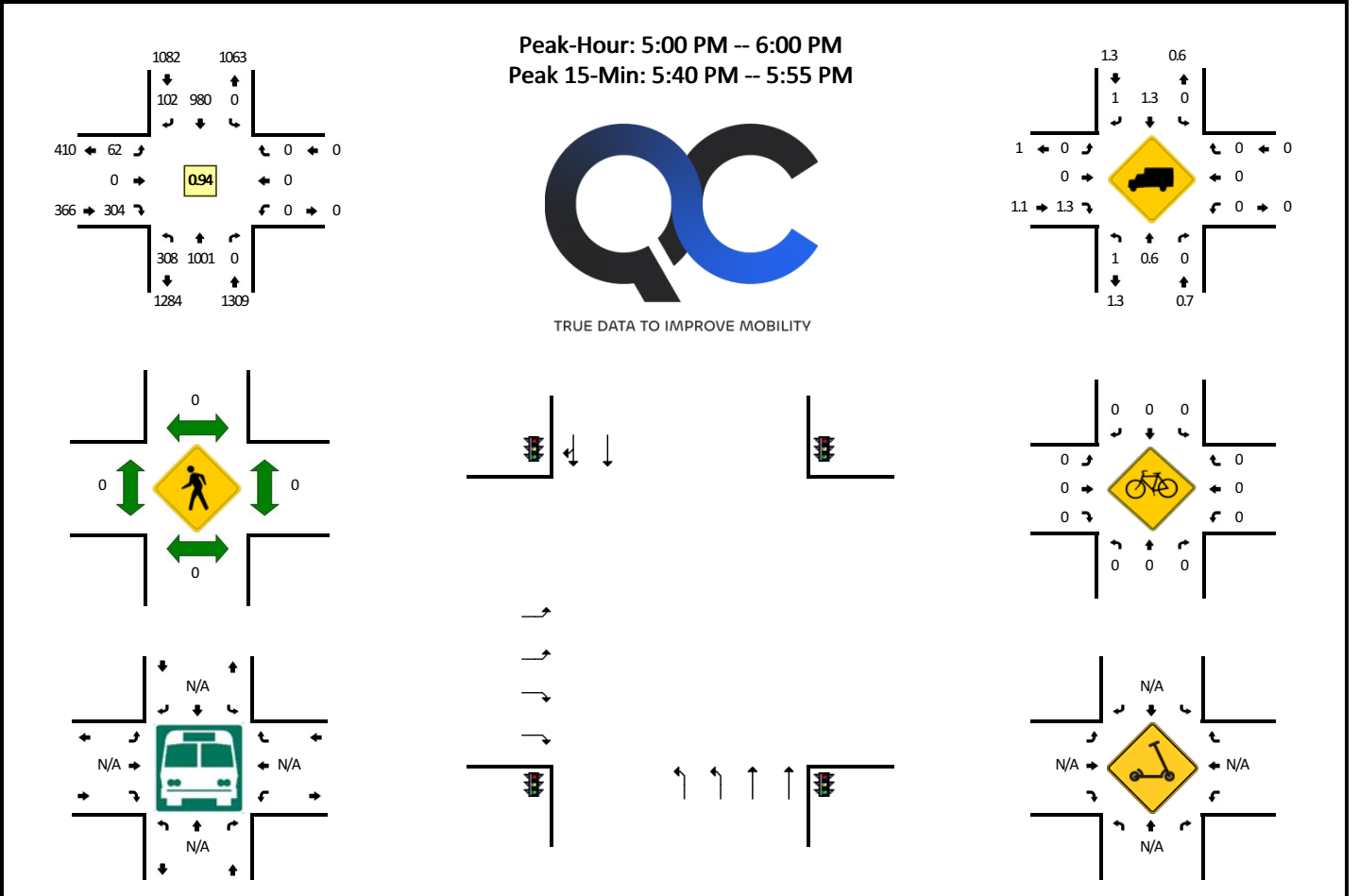

5-Min Count Period Beginning At	Fallon Rd (Northbound)				Fallon Rd (Southbound)				Fallon Gateway (Eastbound)				Fallon Gateway (Westbound)				Total	Hourly Totals
	Left	Thru	Right	U	Left	Thru	Right	U	Left	Thru	Right	U	Left	Thru	Right	U		
4:00 PM	35	54	0	0	0	75	5	0	3	0	21	0	0	0	0	0	193	
4:05 PM	31	48	0	0	0	87	8	0	1	0	27	0	0	0	0	0	202	
4:10 PM	22	59	0	0	0	112	5	0	3	0	26	0	0	0	0	0	227	
4:15 PM	26	55	0	0	0	104	6	0	3	0	35	0	0	0	0	0	229	
4:20 PM	26	50	0	0	0	82	5	0	4	0	26	0	0	0	0	0	193	
4:25 PM	28	52	0	0	0	66	4	0	5	0	21	0	0	0	0	0	176	
4:30 PM	22	61	0	0	0	80	6	0	5	0	23	0	0	0	0	0	197	
4:35 PM	18	66	0	0	0	98	5	0	2	0	33	0	0	0	0	0	222	
4:40 PM	15	56	0	0	0	105	7	0	4	0	25	0	0	0	0	0	212	
4:45 PM	24	58	0	0	0	76	7	0	5	0	27	0	0	0	0	0	197	
4:50 PM	30	58	0	0	0	88	10	0	6	0	24	0	0	0	0	0	216	
4:55 PM	30	60	0	0	0	76	5	0	5	0	25	0	0	0	0	0	201	2465
5:00 PM	42	67	0	0	0	78	7	0	7	0	21	0	0	0	0	0	222	2494
5:05 PM	21	67	0	0	0	110	7	0	2	0	26	0	0	0	0	0	233	2525
5:10 PM	15	81	0	0	0	91	8	0	2	0	22	0	0	0	0	0	219	2517
5:15 PM	33	98	0	0	0	75	9	0	11	0	28	0	0	0	0	0	254	2542
5:20 PM	24	81	0	0	0	91	4	0	6	0	26	0	0	0	0	0	232	2581
5:25 PM	22	85	0	0	0	75	12	0	2	0	19	0	0	0	0	0	215	2620
5:30 PM	32	75	0	0	0	68	8	0	5	0	29	0	0	0	0	0	217	2640
5:35 PM	23	83	0	0	0	88	9	0	2	0	26	0	0	0	0	0	231	2649
5:40 PM	18	92	0	0	0	68	4	0	10	0	32	0	0	0	0	0	224	2661
5:45 PM	19	102	0	0	0	101	13	0	6	0	22	0	0	0	0	0	263	2727
5:50 PM	29	100	0	0	0	73	12	0	4	0	27	0	0	0	0	0	245	2756
5:55 PM	30	70	0	0	0	62	9	0	5	0	26	0	0	0	0	0	202	2757
Peak 15-Min Flowrates	Northbound				Southbound				Eastbound				Westbound				Total	
	Left	Thru	Right	U	Left	Thru	Right	U	Left	Thru	Right	U	Left	Thru	Right	U		
All Vehicles	264	1176	0	0	0	968	116	0	80	0	324	0	0	0	0	0	2928	
Heavy Trucks	4	4	0	0	0	16	4	0	0	0	0	0	0	0	0	0	28	
Buses																		
Pedestrians	0	0	0	0	0	0	0	0	0	0	0	0	0	0	0	0	0	
Bicycles																		
Scooters																		

Comments:

**LOCATION:** Fallon Rd -- I-580 WB Ramps  
**CITY/STATE:** Dublin, CA

**QC JOB #:** 16444315  
**DATE:** Thu, Jan 18 2024

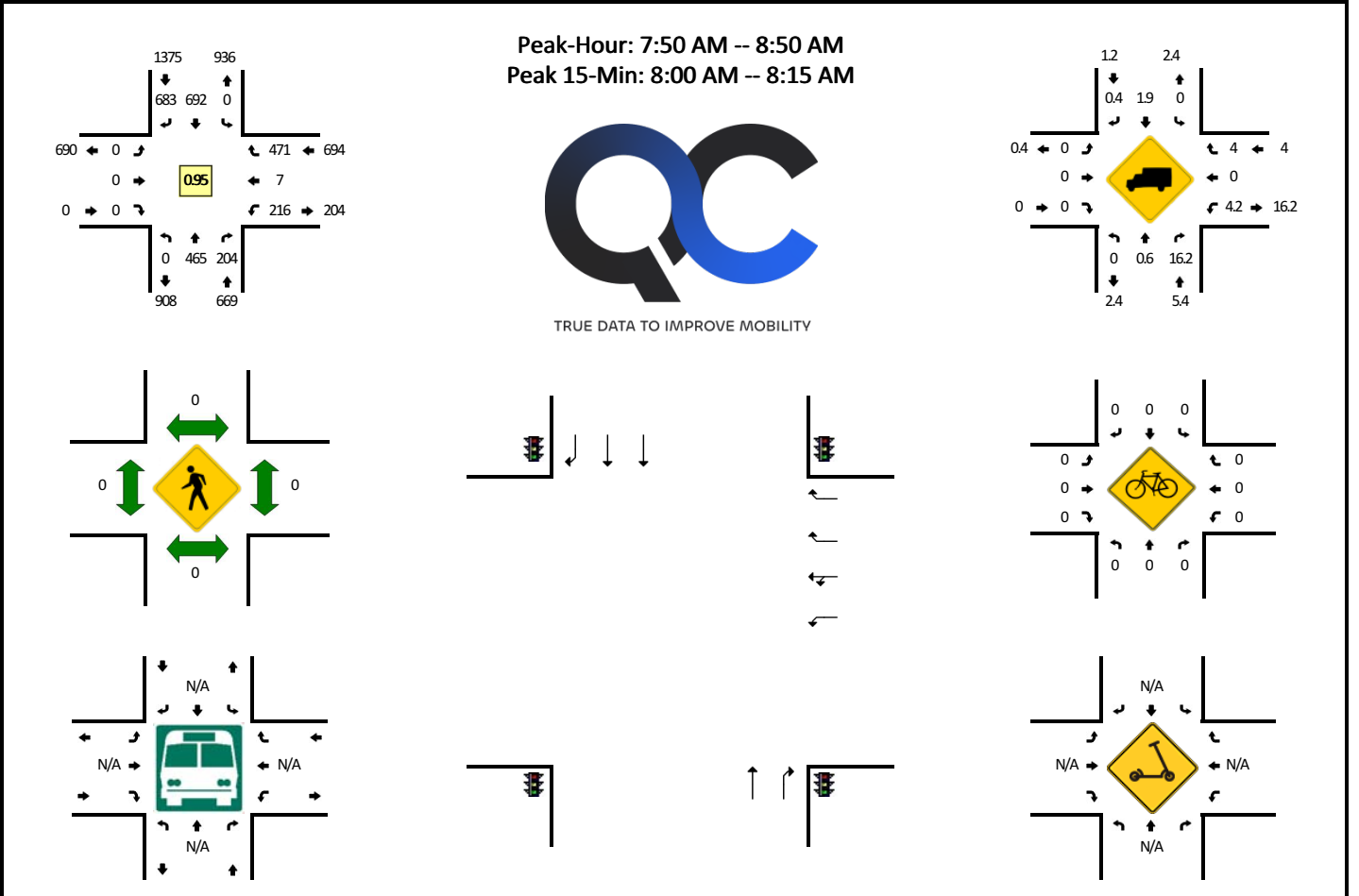

5-Min Count Period Beginning At	Fallon Rd (Northbound)				Fallon Rd (Southbound)				I-580 WB Ramps (Eastbound)				I-580 WB Ramps (Westbound)				Total	Hourly Totals
	Left	Thru	Right	U	Left	Thru	Right	U	Left	Thru	Right	U	Left	Thru	Right	U		
7:00 AM	0	15	11	0	0	20	40	0	0	0	0	0	4	1	21	0	112	
7:05 AM	0	12	8	0	0	22	25	0	0	0	0	0	12	0	24	0	103	
7:10 AM	0	13	9	0	0	17	23	0	0	0	0	0	12	0	21	0	95	
7:15 AM	0	20	12	0	0	26	27	0	0	0	0	0	7	0	34	0	126	
7:20 AM	0	23	15	0	0	32	24	0	0	0	0	0	6	0	27	0	127	
7:25 AM	0	29	13	0	0	28	17	0	0	0	0	0	13	0	25	0	125	
7:30 AM	0	23	11	0	0	55	32	0	0	0	0	0	8	1	34	0	164	
7:35 AM	0	38	16	0	0	41	30	0	0	0	0	0	17	0	35	0	177	
7:40 AM	0	23	13	0	0	41	41	0	0	0	0	0	14	0	38	0	170	
7:45 AM	0	36	16	0	0	37	51	0	0	0	0	0	14	0	34	0	188	
7:50 AM	0	33	19	0	0	56	54	0	0	0	0	0	16	0	49	0	227	
7:55 AM	0	35	22	0	0	48	86	0	0	0	0	0	22	0	26	0	239	1853
8:00 AM	0	43	16	0	0	41	81	0	0	0	0	0	25	1	35	0	242	1983
8:05 AM	0	26	21	0	0	54	71	0	0	0	0	0	19	0	33	0	224	2104
8:10 AM	0	33	21	0	0	67	64	0	0	0	0	0	20	2	44	0	251	2260
8:15 AM	0	25	17	0	0	63	58	0	0	0	0	0	19	0	38	0	220	2354
8:20 AM	0	29	18	0	0	61	60	0	0	0	0	0	17	0	47	0	232	2459
8:25 AM	0	43	10	0	0	69	44	0	0	0	0	0	12	0	39	0	217	2551
8:30 AM	0	46	18	0	0	55	26	0	0	0	0	0	15	2	39	0	201	2588
8:35 AM	0	49	12	0	0	58	53	0	0	0	0	0	19	0	36	0	227	2638
8:40 AM	0	63	17	0	0	55	43	0	0	0	0	0	15	1	45	0	239	2707
8:45 AM	0	40	13	0	0	65	43	0	0	0	0	0	17	1	40	0	219	2738
8:50 AM	0	43	16	0	0	43	23	0	0	0	0	0	15	1	42	0	183	2694
8:55 AM	0	48	16	0	0	63	37	0	0	0	0	0	21	0	30	0	215	2670
Peak 15-Min Flowrates	Northbound				Southbound				Eastbound				Westbound				Total	
	Left	Thru	Right	U	Left	Thru	Right	U	Left	Thru	Right	U	Left	Thru	Right	U		
All Vehicles	0	408	232	0	0	648	864	0	0	0	0	0	256	12	448	0	2868	
Heavy Trucks	0	0	48		0	8	4		0	0	0		12	0	16		88	
Buses																		
Pedestrians	0	0	0		0	0	0		0	0	0		0	0	0		0	
Bicycles	0	0	0		0	0	0		0	0	0		0	0	0		0	
Scoters																		

Comments:

**LOCATION:** Fallon Rd -- I-580 WB Ramps  
**CITY/STATE:** Dublin, CA

**QC JOB #:** 16444316  
**DATE:** Thu, Jan 18 2024

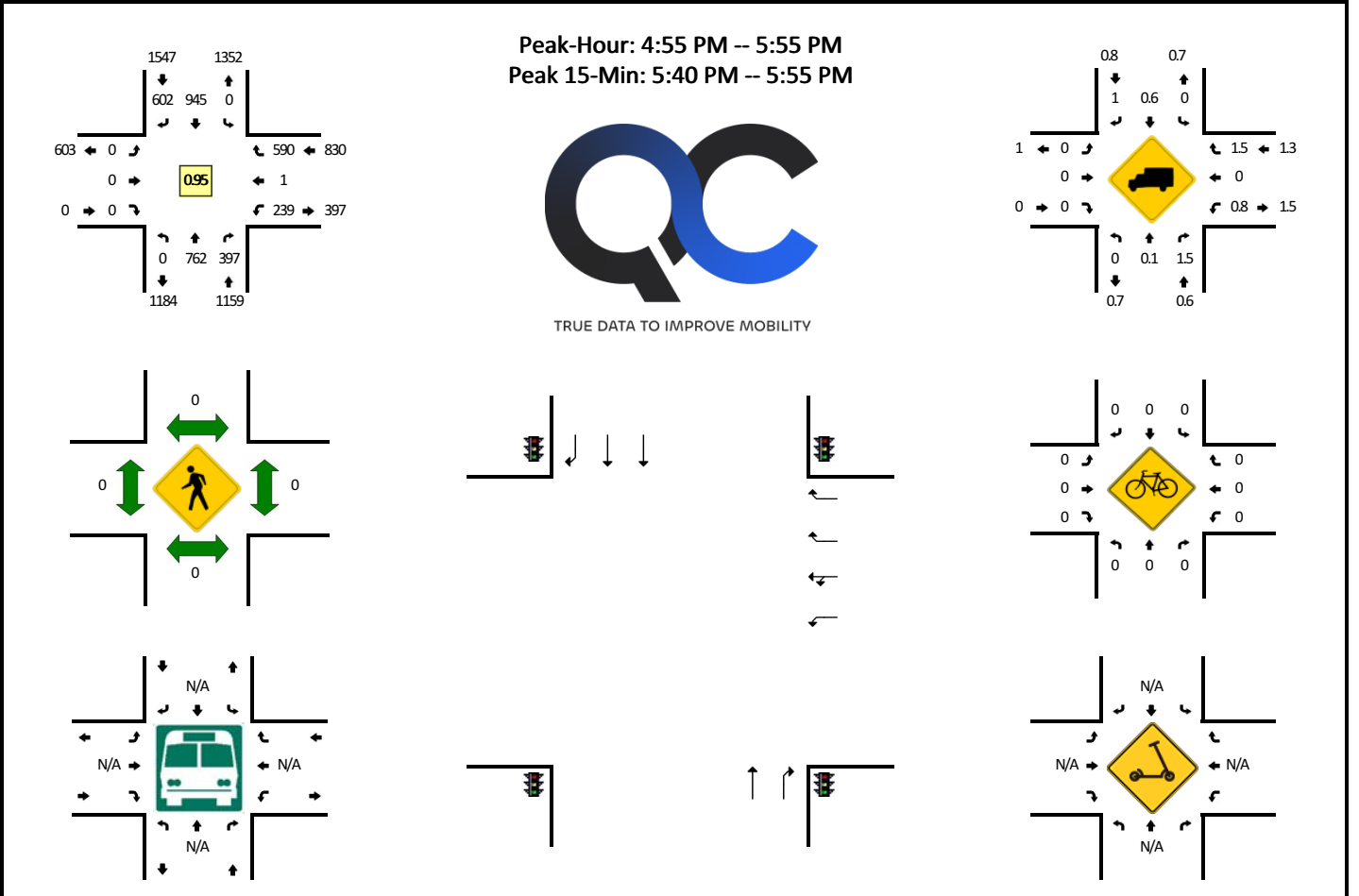

5-Min Count Period Beginning At	Fallon Rd (Northbound)				Fallon Rd (Southbound)				I-580 WB Ramps (Eastbound)				I-580 WB Ramps (Westbound)				Total	Hourly Totals
	Left	Thru	Right	U	Left	Thru	Right	U	Left	Thru	Right	U	Left	Thru	Right	U		
4:00 PM	0	47	33	0	0	72	38	0	0	0	0	0	19	0	27	0	236	
4:05 PM	0	60	37	0	0	69	35	0	0	0	0	0	23	0	39	0	263	
4:10 PM	0	95	42	0	0	80	49	0	0	0	0	0	15	1	32	0	314	
4:15 PM	0	64	31	0	0	93	31	0	0	0	0	0	24	0	38	0	281	
4:20 PM	0	59	43	0	0	77	39	0	0	0	0	0	22	0	47	0	287	
4:25 PM	0	55	35	0	0	69	42	0	0	0	0	0	23	0	44	0	268	
4:30 PM	0	39	22	0	0	68	32	0	0	0	0	0	15	0	38	0	214	
4:35 PM	0	43	52	0	0	85	45	0	0	0	0	0	17	0	46	0	288	
4:40 PM	0	59	41	0	0	95	38	0	0	0	0	0	12	0	31	0	276	
4:45 PM	0	44	32	0	0	66	36	0	0	0	0	0	22	0	50	0	250	
4:50 PM	0	64	34	0	0	71	36	0	0	0	0	0	18	1	45	0	269	
4:55 PM	0	44	25	0	0	81	44	0	0	0	0	0	27	0	46	0	267	3213
5:00 PM	0	61	27	0	0	98	32	0	0	0	0	0	21	0	46	0	285	3262
5:05 PM	0	63	37	0	0	77	41	0	0	0	0	0	16	0	38	0	272	3271
5:10 PM	0	61	38	0	0	74	54	0	0	0	0	0	22	0	47	0	296	3253
5:15 PM	0	65	44	0	0	86	43	0	0	0	0	0	24	0	45	0	307	3279
5:20 PM	0	63	30	0	0	80	52	0	0	0	0	0	16	0	52	0	293	3285
5:25 PM	0	63	37	0	0	62	39	0	0	0	0	0	19	0	67	0	287	3304
5:30 PM	0	62	29	0	0	80	55	0	0	0	0	0	17	0	48	0	291	3381
5:35 PM	0	73	35	0	0	76	51	0	0	0	0	0	19	0	56	0	310	3403
5:40 PM	0	67	31	0	0	77	67	0	0	0	0	0	15	1	52	0	310	3437
5:45 PM	0	57	32	0	0	61	69	0	0	0	0	0	23	0	41	0	283	3470
5:50 PM	0	83	32	0	0	93	55	0	0	0	0	0	20	0	52	0	335	3536
5:55 PM	0	72	24	0	0	54	46	0	0	0	0	0	16	0	48	0	260	3529
Peak 15-Min Flowrates	Northbound				Southbound				Eastbound				Westbound				Total	
	Left	Thru	Right	U	Left	Thru	Right	U	Left	Thru	Right	U	Left	Thru	Right	U		
All Vehicles	0	828	380	0	0	924	764	0	0	0	0	0	232	4	580	0	3712	
Heavy Trucks	0	0	0		0	4	12		0	0	0		0	0	12		28	
Buses																		
Pedestrians	0	0			0	0			0	0			0	0			0	
Bicycles	0	0			0	0			0	0			0	0			0	
Scooters																		

Comments:

**LOCATION:** El Charro Rd -- I-580 EB Ramps  
**CITY/STATE:** Pleasanton, CA

**QC JOB #:** 16444317  
**DATE:** Thu, Jan 18 2024

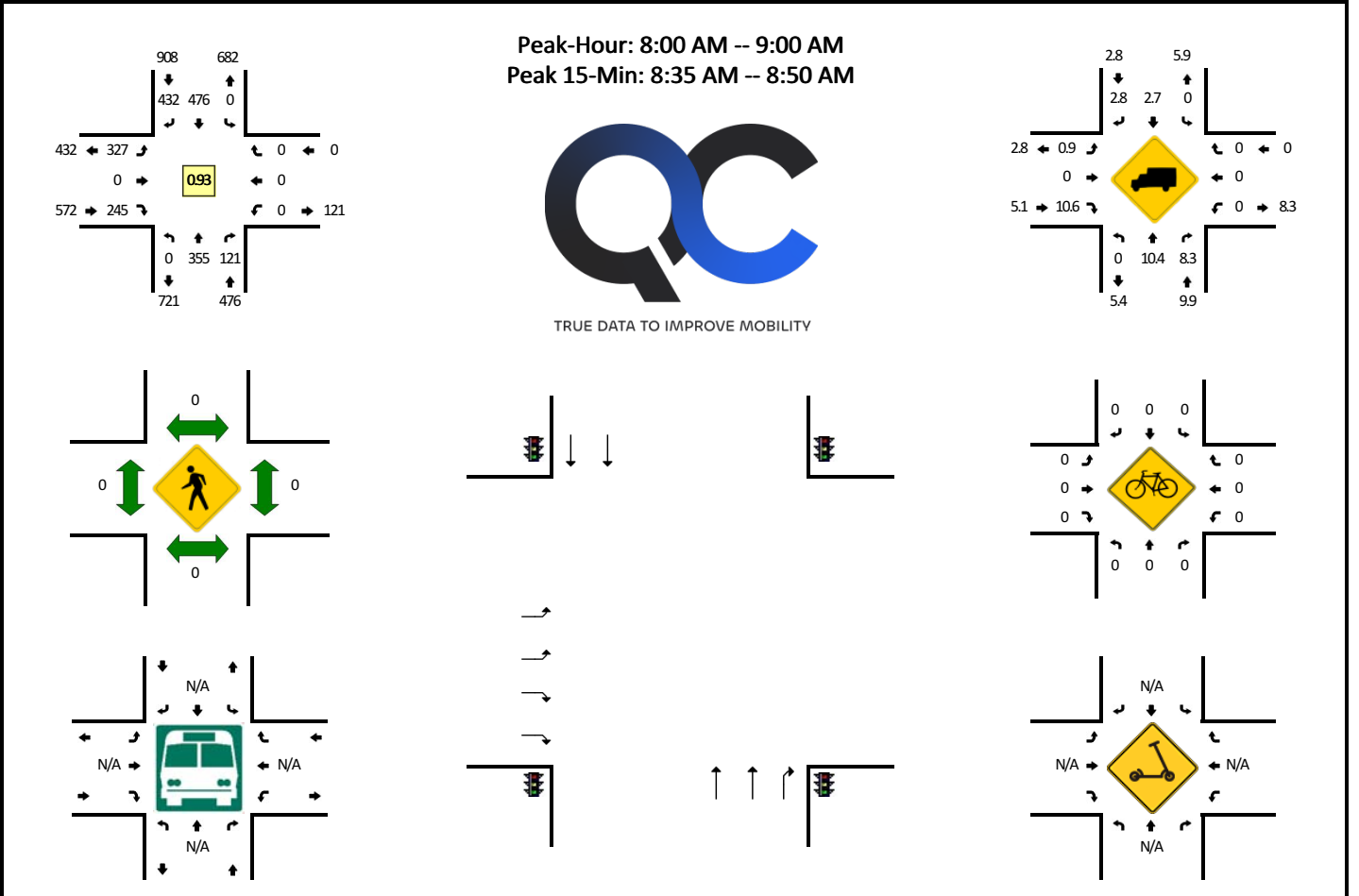

5-Min Count Period Beginning At	El Charro Rd (Northbound)				El Charro Rd (Southbound)				I-580 EB Ramps (Eastbound)				I-580 EB Ramps (Westbound)				Total	Hourly Totals
	Left	Thru	Right	U	Left	Thru	Right	U	Left	Thru	Right	U	Left	Thru	Right	U		
7:00 AM	0	15	4	0	0	10	14	0	11	0	10	0	0	0	0	0	64	
7:05 AM	0	14	7	0	0	19	14	0	9	0	8	0	0	0	0	0	71	
7:10 AM	0	8	7	0	0	10	17	0	13	0	8	0	0	0	0	0	63	
7:15 AM	0	18	7	0	0	21	10	0	13	0	10	0	0	0	0	0	79	
7:20 AM	0	19	10	0	0	18	25	0	21	0	8	0	0	0	0	0	101	
7:25 AM	0	23	9	0	0	23	18	0	20	0	11	0	0	0	0	0	104	
7:30 AM	0	23	13	0	0	30	22	0	10	0	12	0	0	0	0	0	110	
7:35 AM	0	34	9	0	0	24	36	0	23	0	17	0	0	0	0	0	143	
7:40 AM	0	22	8	0	0	31	25	0	13	0	19	0	0	0	0	0	118	
7:45 AM	0	27	4	0	0	30	22	0	26	0	19	0	0	0	0	0	128	
7:50 AM	0	29	15	0	0	42	35	0	17	0	20	0	0	0	0	0	158	
7:55 AM	0	38	14	0	0	42	30	0	20	0	20	0	0	0	0	0	164	1303
8:00 AM	0	33	11	0	0	38	23	0	25	0	39	0	0	0	0	0	169	1408
8:05 AM	0	40	8	0	0	33	41	0	17	0	16	0	0	0	0	0	155	1492
8:10 AM	0	34	17	0	0	53	37	0	13	0	17	0	0	0	0	0	171	1600
8:15 AM	0	26	8	0	0	38	39	0	19	0	18	0	0	0	0	0	148	1669
8:20 AM	0	24	12	0	0	44	39	0	21	0	10	0	0	0	0	0	150	1718
8:25 AM	0	23	9	0	0	47	35	0	30	0	19	0	0	0	0	0	163	1777
8:30 AM	0	33	4	0	0	36	29	0	33	0	9	0	0	0	0	0	144	1811
8:35 AM	0	22	6	0	0	38	37	0	39	0	22	0	0	0	0	0	164	1832
8:40 AM	0	27	8	0	0	38	37	0	49	0	27	0	0	0	0	0	186	1900
8:45 AM	0	27	21	0	0	47	37	0	24	0	19	0	0	0	0	0	175	1947
8:50 AM	0	36	8	0	0	22	30	0	24	0	24	0	0	0	0	0	144	1933
8:55 AM	0	30	9	0	0	42	48	0	33	0	25	0	0	0	0	0	187	1956
Peak 15-Min Flowrates	Northbound				Southbound				Eastbound				Westbound				Total	
	Left	Thru	Right	U	Left	Thru	Right	U	Left	Thru	Right	U	Left	Thru	Right	U		
All Vehicles	0	304	140	0	0	492	444	0	448	0	272	0	0	0	0	0	2100	
Heavy Trucks	0	40	12		0	16	24		8	0	32		0	0	0		132	
Buses																		
Pedestrians	0	0			0	0			0	0			0	0			0	
Bicycles	0	0			0	0			0	0			0	0			0	
Scoters																		

Comments:

**LOCATION:** El Charro Rd -- I-580 EB Ramps  
**CITY/STATE:** Pleasanton, CA

**QC JOB #:** 16444318  
**DATE:** Thu, Jan 18 2024

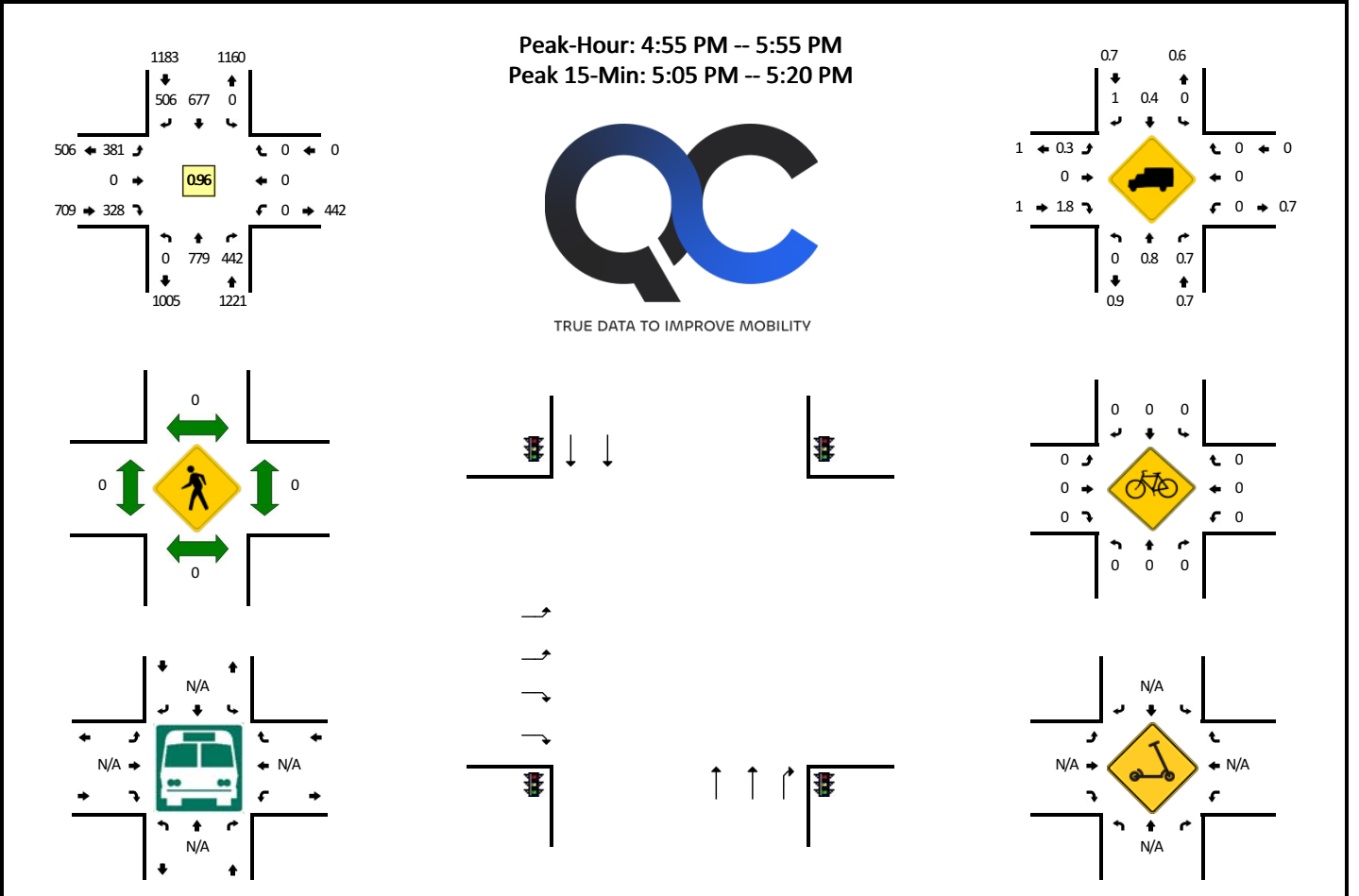

5-Min Count Period Beginning At	El Charro Rd (Northbound)				El Charro Rd (Southbound)				I-580 EB Ramps (Eastbound)				I-580 EB Ramps (Westbound)				Total	Hourly Totals
	Left	Thru	Right	U	Left	Thru	Right	U	Left	Thru	Right	U	Left	Thru	Right	U		
4:00 PM	0	49	25	0	0	48	43	0	30	0	27	0	0	0	0	0	222	
4:05 PM	0	77	30	0	0	42	43	0	42	0	26	0	0	0	0	0	260	
4:10 PM	0	69	32	0	0	57	45	0	45	0	27	0	0	0	0	0	275	
4:15 PM	0	58	29	0	0	58	49	0	37	0	26	0	0	0	0	0	257	
4:20 PM	0	68	29	0	0	52	55	0	41	0	34	0	0	0	0	0	279	
4:25 PM	0	52	38	0	0	56	38	0	30	0	22	0	0	0	0	0	236	
4:30 PM	0	43	20	0	0	45	38	0	27	0	26	0	0	0	0	0	199	
4:35 PM	0	74	30	0	0	56	44	0	23	0	26	0	0	0	0	0	253	
4:40 PM	0	61	43	0	0	45	60	0	28	0	34	0	0	0	0	0	271	
4:45 PM	0	57	28	0	0	55	37	0	20	0	18	0	0	0	0	0	215	
4:50 PM	0	67	38	0	0	55	33	0	30	0	21	0	0	0	0	0	244	
4:55 PM	0	55	26	0	0	72	37	0	22	0	28	0	0	0	0	0	240	2951
5:00 PM	0	55	28	0	0	56	61	0	38	0	26	0	0	0	0	0	264	2993
5:05 PM	0	71	45	0	0	49	46	0	25	0	25	0	0	0	0	0	261	2994
5:10 PM	0	67	52	0	0	62	33	0	23	0	26	0	0	0	0	0	263	2982
5:15 PM	0	82	35	0	0	72	37	0	33	0	27	0	0	0	0	0	286	3011
5:20 PM	0	66	32	0	0	51	44	0	27	0	29	0	0	0	0	0	249	2981
5:25 PM	0	72	33	0	0	48	36	0	35	0	33	0	0	0	0	0	257	3002
5:30 PM	0	68	39	0	0	51	46	0	28	0	24	0	0	0	0	0	256	3059
5:35 PM	0	62	31	0	0	52	42	0	40	0	26	0	0	0	0	0	253	3059
5:40 PM	0	57	35	0	0	54	39	0	32	0	38	0	0	0	0	0	255	3043
5:45 PM	0	67	43	0	0	42	41	0	35	0	23	0	0	0	0	0	251	3079
5:50 PM	0	57	43	0	0	68	44	0	43	0	23	0	0	0	0	0	278	3113
5:55 PM	0	56	26	0	0	38	34	0	42	0	18	0	0	0	0	0	214	3087
Peak 15-Min Flowrates	Northbound				Southbound				Eastbound				Westbound				Total	
All Vehicles	0	880	528	0	0	732	464	0	324	0	312	0	0	0	0	0	3240	
Heavy Trucks	0	8	4		0	0	8		4	0	8		0	0	0		32	
Buses																	0	
Pedestrians	0	0	0		0	0	0		0	0	0		0	0	0		0	
Bicycles	0	0	0		0	0	0		0	0	0		0	0	0		0	
Scoters																	0	

Comments:



**LOCATION:** Tassajara Rd -- Dublin Blvd  
**CITY/STATE:** Dublin, CA

**QC JOB #:** 16444319  
**DATE:** Thu, Jan 18 2024

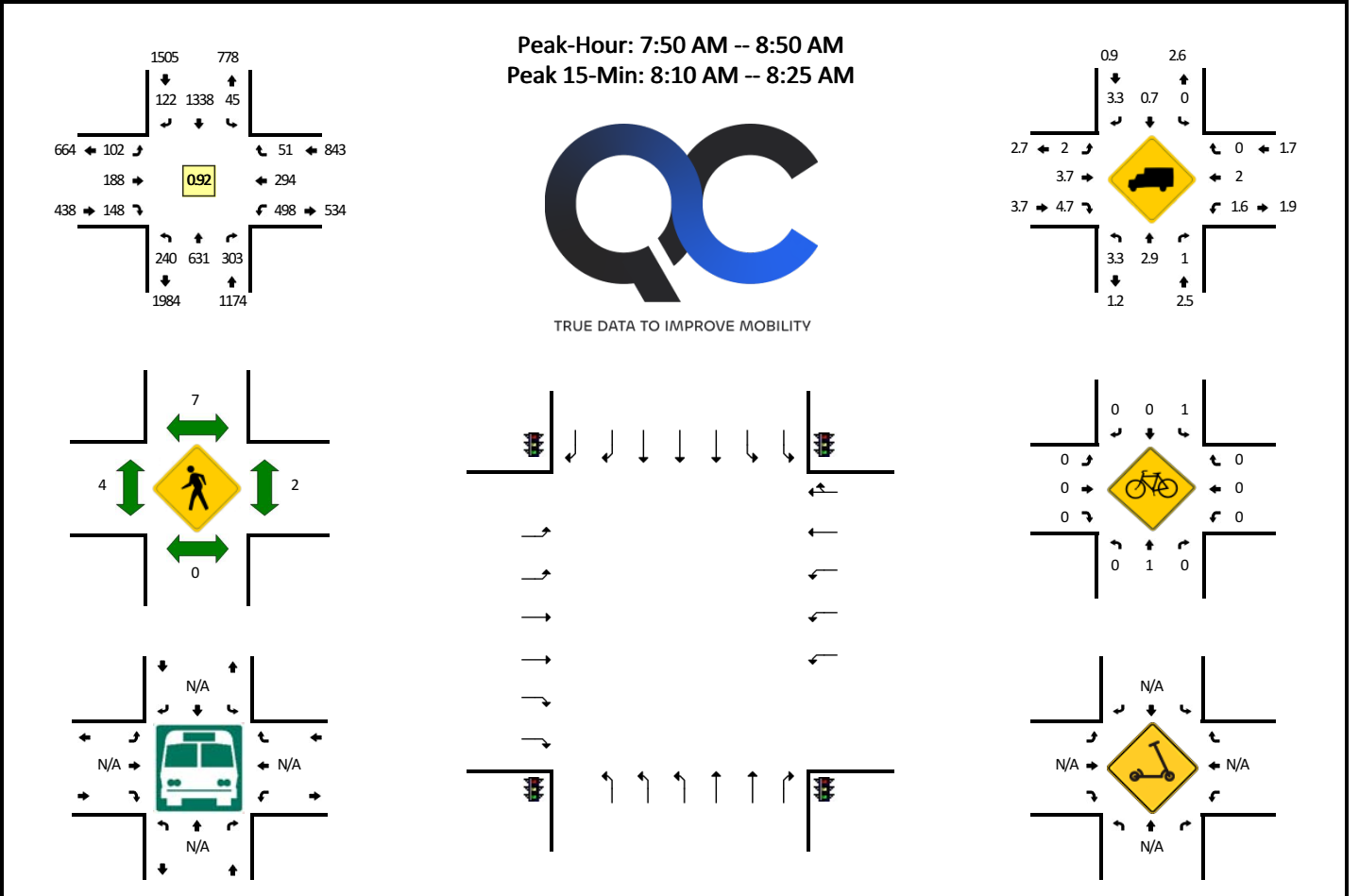

5-Min Count Period Beginning At	Tassajara Rd (Northbound)				Tassajara Rd (Southbound)				Dublin Blvd (Eastbound)				Dublin Blvd (Westbound)				Total	Hourly Totals
	Left	Thru	Right	U	Left	Thru	Right	U	Left	Thru	Right	U	Left	Thru	Right	U		
7:00 AM	6	28	13	0	0	47	9	0	1	1	4	0	22	12	1	0	144	
7:05 AM	11	13	18	1	2	45	5	0	1	7	12	0	21	10	1	0	147	
7:10 AM	8	22	12	0	1	35	5	0	1	5	12	0	26	12	1	0	140	
7:15 AM	8	30	14	0	0	43	3	0	1	5	10	0	21	6	1	0	142	
7:20 AM	10	25	10	0	0	34	6	0	5	9	11	0	19	16	1	0	146	
7:25 AM	7	29	19	1	2	87	4	0	4	8	8	0	30	6	3	0	208	
7:30 AM	11	35	8	0	2	52	7	0	0	11	14	0	25	15	4	0	184	
7:35 AM	14	66	24	0	1	61	4	0	2	6	10	0	17	7	1	0	213	
7:40 AM	11	38	15	0	1	52	5	0	5	4	13	0	41	36	4	0	225	
7:45 AM	20	46	28	1	4	85	7	0	5	6	7	0	35	13	0	0	257	
7:50 AM	11	78	23	0	0	134	14	0	2	7	8	0	47	23	5	0	352	
7:55 AM	14	57	17	0	2	96	17	0	5	8	16	0	42	22	1	0	297	2455
8:00 AM	15	48	26	0	3	99	11	0	6	17	14	0	30	37	3	0	309	2620
8:05 AM	20	51	11	0	3	110	12	0	9	11	12	0	39	27	8	0	313	2786
8:10 AM	32	43	29	0	6	129	12	1	6	14	15	0	50	24	4	0	365	3011
8:15 AM	19	66	28	0	3	159	3	0	10	23	11	1	36	19	7	0	385	3254
8:20 AM	23	39	32	0	7	116	10	0	5	10	10	0	42	30	5	0	329	3437
8:25 AM	25	46	29	0	3	104	10	0	11	15	5	2	47	21	3	0	321	3550
8:30 AM	12	33	27	0	4	89	9	0	9	21	14	1	55	33	5	0	312	3678
8:35 AM	18	50	28	0	5	98	6	1	11	28	13	0	33	25	6	0	322	3787
8:40 AM	23	55	26	0	3	111	9	0	12	17	17	3	39	20	4	0	339	3901
8:45 AM	28	65	27	0	4	93	9	0	8	17	13	1	38	13	0	0	316	3960
8:50 AM	21	69	33	0	5	55	3	0	4	26	16	0	32	21	5	0	290	3898
8:55 AM	29	50	38	0	0	101	10	0	3	15	14	1	41	15	2	0	319	3920
Peak 15-Min Flowrates	Northbound				Southbound				Eastbound				Westbound				Total	
	Left	Thru	Right	U	Left	Thru	Right	U	Left	Thru	Right	U	Left	Thru	Right	U		
All Vehicles	296	592	356	0	64	1616	100	4	84	188	144	4	512	292	64	0	4316	
Heavy Trucks	12	20	4		0	12	0		8	8	4		8	0	0		76	
Buses																		
Pedestrians	0	0				4				8			0	0			12	
Bicycles						0	0			0	0		0	0	0		0	
Scoters																		

Comments:

**LOCATION:** Tassajara Rd -- Dublin Blvd  
**CITY/STATE:** Dublin, CA

**QC JOB #:** 16444320  
**DATE:** Thu, Jan 18 2024

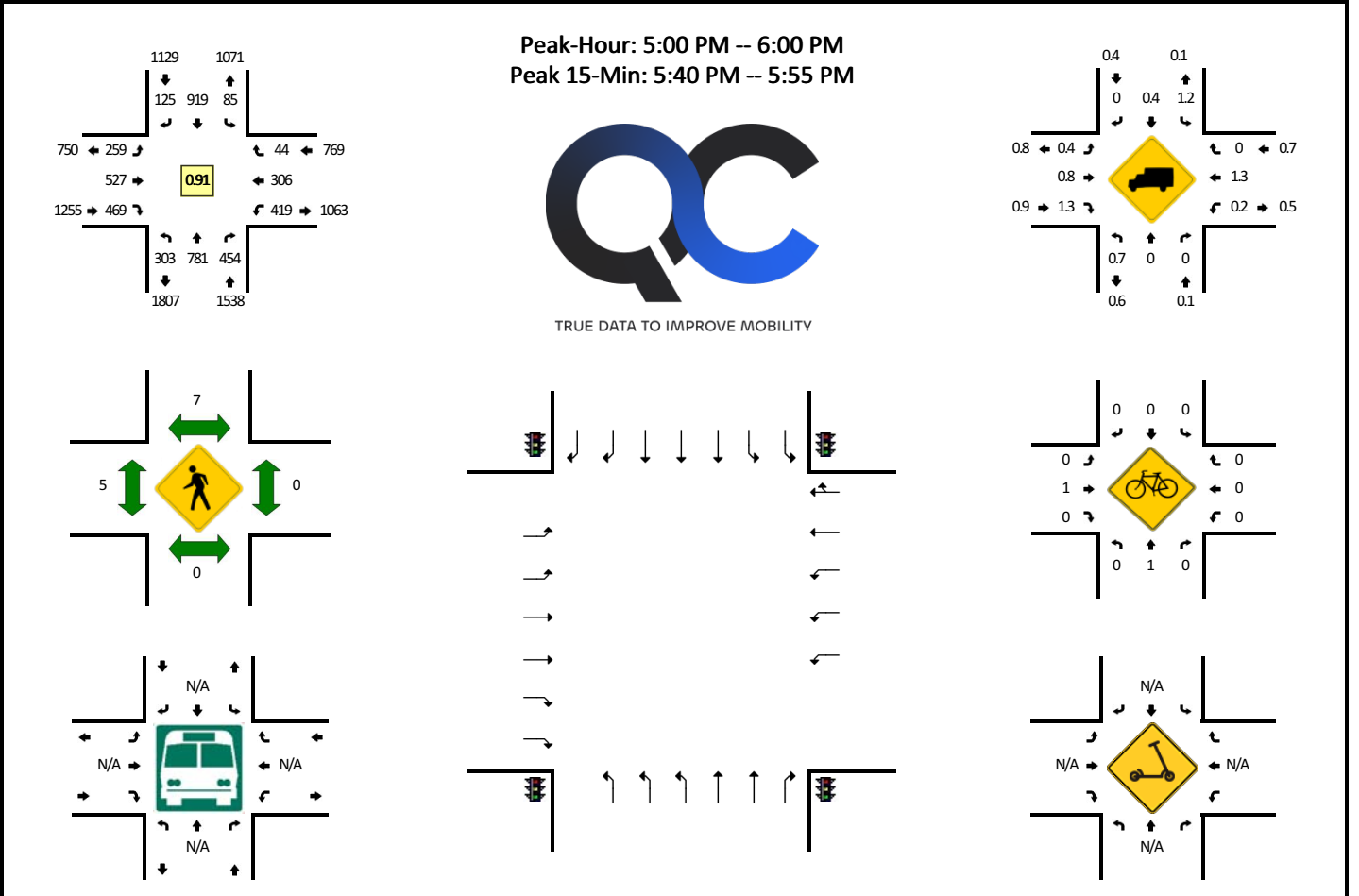

5-Min Count Period Beginning At	Tassajara Rd (Northbound)				Tassajara Rd (Southbound)				Dublin Blvd (Eastbound)				Dublin Blvd (Westbound)				Total	Hourly Totals
	Left	Thru	Right	U	Left	Thru	Right	U	Left	Thru	Right	U	Left	Thru	Right	U		
4:00 PM	38	49	38	1	7	47	12	0	13	24	33	1	31	16	2	0	312	
4:05 PM	16	53	15	0	7	73	14	1	16	40	43	0	43	24	2	0	347	
4:10 PM	26	55	32	0	9	63	10	0	13	58	34	1	32	13	2	0	348	
4:15 PM	20	60	34	0	1	71	8	0	23	55	42	1	24	17	5	0	361	
4:20 PM	20	44	30	0	5	105	11	0	24	53	37	1	44	23	4	0	401	
4:25 PM	39	57	30	0	9	77	9	0	23	50	43	0	29	20	3	0	389	
4:30 PM	36	45	31	0	8	50	8	0	8	43	36	3	19	18	2	0	307	
4:35 PM	17	49	15	0	1	84	8	0	16	42	34	0	43	37	5	0	351	
4:40 PM	29	62	42	0	9	71	4	0	14	41	38	1	45	21	6	0	383	
4:45 PM	16	50	34	0	12	71	17	0	25	46	34	1	35	16	1	0	358	
4:50 PM	29	48	28	0	2	63	8	0	18	45	36	2	44	22	4	0	349	
4:55 PM	22	59	30	0	5	79	5	0	14	31	38	0	53	36	5	0	377	4283
5:00 PM	24	64	39	0	4	95	6	0	20	23	29	1	46	26	2	0	379	4350
5:05 PM	19	52	28	0	6	64	9	0	13	31	36	1	33	20	5	0	317	4320
5:10 PM	26	72	33	0	9	79	4	0	23	66	37	1	37	12	5	0	404	4376
5:15 PM	24	80	41	0	6	67	7	1	22	24	37	0	35	30	4	0	378	4393
5:20 PM	31	57	32	0	4	77	10	0	16	45	34	1	37	34	1	0	379	4371
5:25 PM	34	68	38	0	9	87	15	0	15	54	36	1	20	21	5	0	403	4385
5:30 PM	26	44	31	0	7	58	12	1	33	45	46	6	31	18	6	0	364	4442
5:35 PM	28	51	30	0	7	68	8	0	14	59	41	1	30	35	4	0	376	4467
5:40 PM	12	71	47	0	6	97	14	0	20	39	38	0	41	30	4	0	419	4503
5:45 PM	23	72	40	0	4	80	8	0	26	65	52	1	50	35	3	0	459	4604
5:50 PM	34	87	44	0	10	78	11	1	26	22	42	0	33	24	2	0	414	4669
5:55 PM	22	63	51	0	10	69	21	0	15	54	41	3	26	21	3	0	399	4691
Peak 15-Min Flowrates	Northbound				Southbound				Eastbound				Westbound				Total	
	Left	Thru	Right	U	Left	Thru	Right	U	Left	Thru	Right	U	Left	Thru	Right	U		
All Vehicles	276	920	524	0	80	1020	132	4	288	504	528	4	496	356	36	0	5168	
Heavy Trucks	4	0	0		0	0	0		0	0	4		0	0	0		8	
Buses																		
Pedestrians	0	0	0		0	0	0		8	0	0		0	0	0		8	
Bicycles	0	0	0		0	0	0		0	0	0		0	0	0		0	
Scoters																		

Comments:

**LOCATION:** Tassajara Rd -- Central Pkwy  
**CITY/STATE:** Dublin, CA

**QC JOB #:** 16444321  
**DATE:** Thu, Jan 18 2024

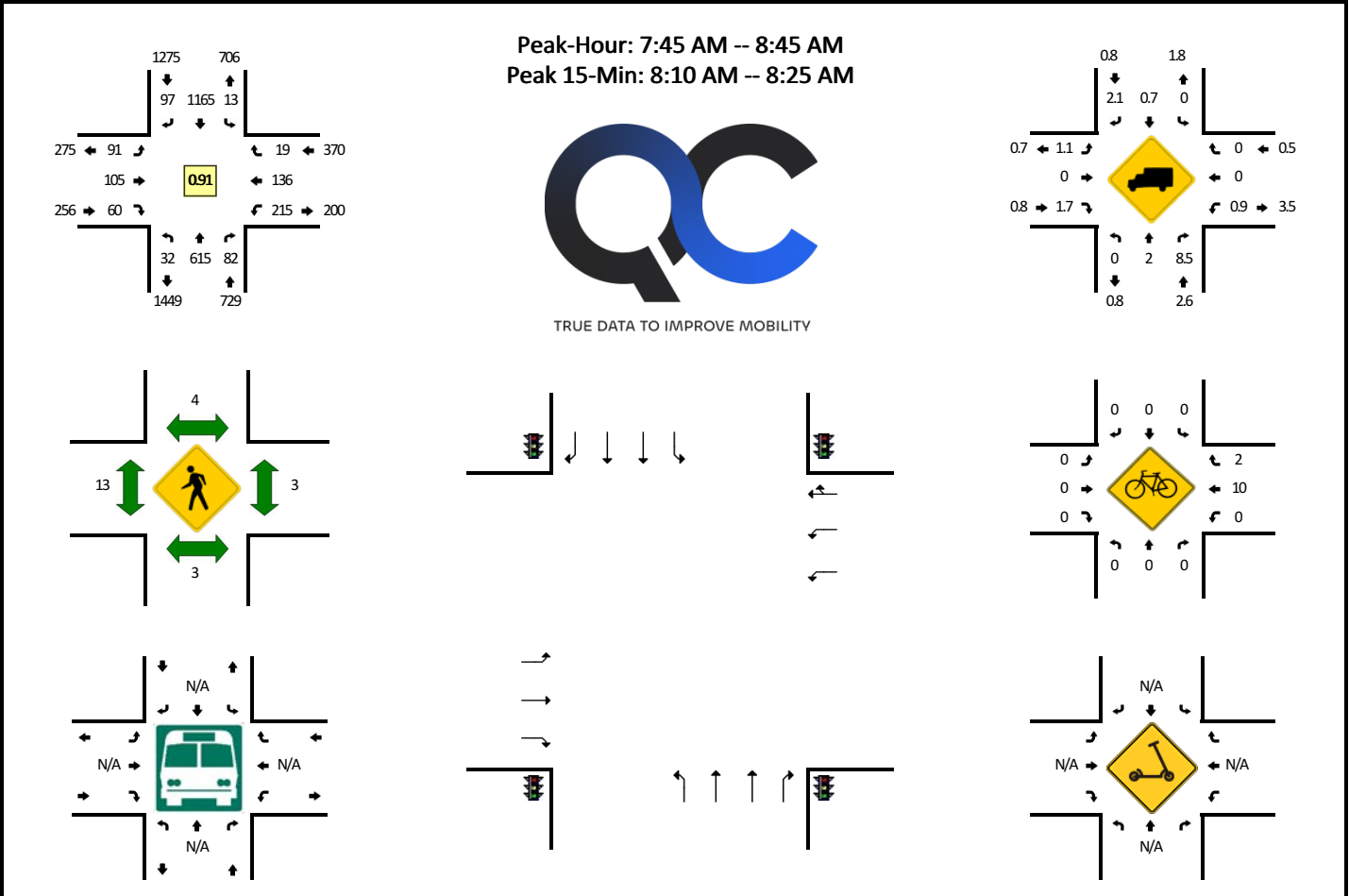

5-Min Count Period Beginning At	Tassajara Rd (Northbound)				Tassajara Rd (Southbound)				Central Pkwy (Eastbound)				Central Pkwy (Westbound)				Total	Hourly Totals
	Left	Thru	Right	U	Left	Thru	Right	U	Left	Thru	Right	U	Left	Thru	Right	U		
7:00 AM	2	23	6	0	0	49	0	0	0	3	0	0	9	6	0	0	98	
7:05 AM	0	13	1	0	1	38	0	0	1	2	0	0	6	2	0	0	64	
7:10 AM	2	14	8	0	1	19	1	0	1	3	4	0	4	1	0	0	58	
7:15 AM	1	25	6	0	1	45	0	0	2	4	2	0	10	1	0	0	97	
7:20 AM	1	29	4	0	0	40	2	0	1	4	3	0	3	3	2	0	92	
7:25 AM	2	23	1	0	0	52	3	0	3	3	1	0	9	7	1	0	105	
7:30 AM	1	39	6	0	0	51	2	0	4	5	2	0	15	3	0	0	128	
7:35 AM	1	51	3	0	0	46	3	0	4	3	2	1	6	10	0	0	130	
7:40 AM	1	55	3	1	0	57	2	0	5	4	3	0	18	15	1	0	165	
7:45 AM	0	45	5	0	1	107	3	0	1	4	3	0	10	9	2	0	190	
7:50 AM	2	52	5	1	0	74	6	0	5	3	1	1	15	11	0	0	176	
7:55 AM	1	76	6	0	1	116	8	0	5	4	2	0	15	9	0	0	243	1546
8:00 AM	5	52	3	1	0	85	6	0	8	7	3	4	33	17	2	0	226	1674
8:05 AM	1	56	6	1	0	96	20	0	4	10	6	4	15	7	3	0	229	1839
8:10 AM	1	41	11	1	1	115	9	0	12	20	8	4	23	8	0	0	254	2035
8:15 AM	3	52	8	1	0	93	8	0	9	16	11	5	18	11	4	0	239	2177
8:20 AM	1	40	2	1	3	82	7	0	15	24	10	0	22	21	2	0	230	2315
8:25 AM	3	56	6	1	4	115	10	0	4	7	3	1	26	10	1	0	247	2457
8:30 AM	1	38	8	0	2	89	10	0	2	3	4	0	19	17	1	0	194	2523
8:35 AM	3	51	8	1	0	93	7	0	1	5	4	0	13	10	2	0	198	2591
8:40 AM	2	56	14	1	1	100	3	0	6	2	5	0	6	6	2	0	204	2630
8:45 AM	3	36	20	0	2	61	3	0	1	8	2	0	9	6	0	0	151	2591
8:50 AM	4	67	9	0	0	62	5	0	1	6	6	0	6	8	1	0	175	2590
8:55 AM	1	54	6	0	1	73	2	0	4	6	2	0	20	4	0	0	173	2520
Peak 15-Min Flowrates	Northbound				Southbound				Eastbound				Westbound				Total	
	Left	Thru	Right	U	Left	Thru	Right	U	Left	Thru	Right	U	Left	Thru	Right	U		
All Vehicles	20	532	84	12	16	1160	96	0	144	240	116	36	252	160	24	0	2892	
Heavy Trucks	0	16	4		0	0	0		0	0	4		0	0	0		24	
Buses																		
Pedestrians		4				0				4				0			8	
Bicycles	0	0	0		0	0	0		0	0	0		0	4	4		8	
Scoters																		

*Comments:*

**LOCATION:** Tassajara Rd -- Central Pkwy  
**CITY/STATE:** Dublin, CA

**QC JOB #:** 16444322  
**DATE:** Thu, Jan 18 2024

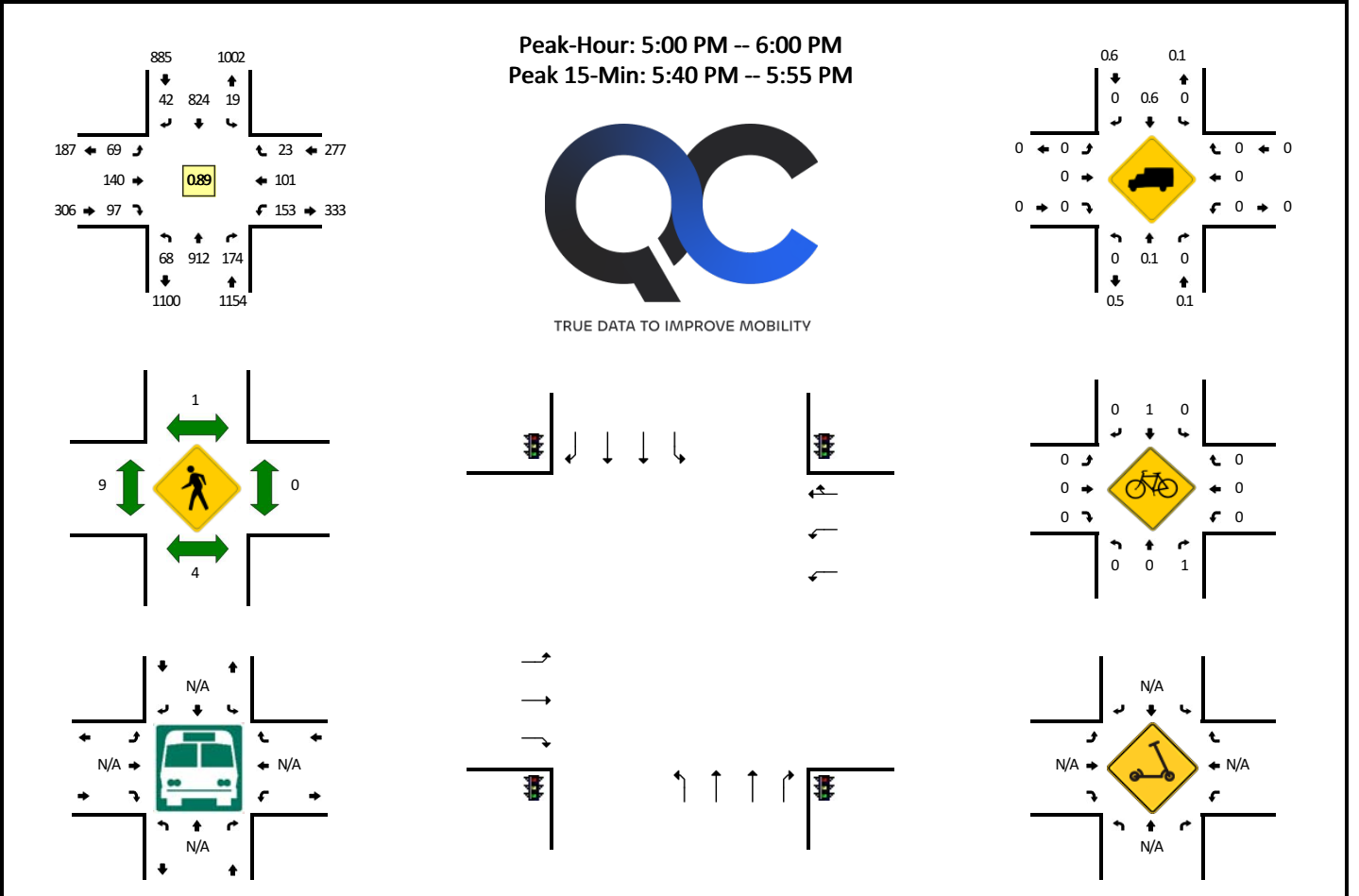

5-Min Count Period Beginning At	Tassajara Rd (Northbound)				Tassajara Rd (Southbound)				Central Pkwy (Eastbound)				Central Pkwy (Westbound)				Total	Hourly Totals
	Left	Thru	Right	U	Left	Thru	Right	U	Left	Thru	Right	U	Left	Thru	Right	U		
4:00 PM	2	59	11	1	0	69	4	0	0	3	10	1	5	5	0	0	170	
4:05 PM	5	50	14	2	0	74	2	0	4	10	4	0	6	3	1	0	175	
4:10 PM	3	57	10	2	1	61	4	0	2	13	7	0	5	1	2	0	168	
4:15 PM	3	58	15	0	4	92	7	0	4	10	7	0	7	5	0	0	212	
4:20 PM	7	61	17	1	1	72	10	0	5	6	9	0	11	6	2	0	208	
4:25 PM	1	36	11	1	1	56	10	0	6	15	7	0	5	7	3	0	159	
4:30 PM	6	78	11	2	1	64	2	1	1	6	8	0	7	4	1	0	192	
4:35 PM	2	64	8	2	0	72	6	0	3	12	8	0	13	2	1	0	193	
4:40 PM	4	73	8	1	0	52	6	0	2	14	8	1	17	6	0	0	192	
4:45 PM	2	57	10	0	0	71	4	0	4	9	8	0	7	0	0	0	172	
4:50 PM	8	67	24	3	2	69	5	1	7	12	8	0	17	6	3	0	232	
4:55 PM	3	49	11	3	0	47	7	0	5	11	9	0	10	7	2	0	164	2237
5:00 PM	3	84	13	2	2	84	3	0	10	7	5	0	8	4	1	0	226	2293
5:05 PM	8	60	11	1	1	76	4	0	4	8	11	1	11	7	1	0	204	2322
5:10 PM	7	51	16	1	0	43	6	0	4	8	7	0	10	9	3	0	165	2319
5:15 PM	2	94	12	1	0	71	3	0	3	14	9	0	11	7	2	0	229	2336
5:20 PM	4	79	13	2	2	79	4	0	5	13	11	0	7	8	2	0	229	2357
5:25 PM	2	51	10	4	3	69	4	0	5	16	7	0	15	9	0	0	195	2393
5:30 PM	3	87	12	2	0	58	3	0	11	20	8	0	18	2	0	0	224	2425
5:35 PM	1	69	9	2	4	87	2	0	5	7	4	0	17	11	1	0	219	2451
5:40 PM	5	83	23	2	4	78	6	0	3	12	11	0	11	17	2	0	257	2516
5:45 PM	3	73	22	2	3	51	3	0	7	14	14	0	14	11	3	0	220	2564
5:50 PM	1	84	18	4	0	85	2	0	9	15	5	1	22	10	5	0	261	2593
5:55 PM	3	97	15	3	0	43	2	0	1	6	5	0	9	6	3	0	193	2622
Peak 15-Min Flowrates	Northbound				Southbound				Eastbound				Westbound				Total	
	Left	Thru	Right	U	Left	Thru	Right	U	Left	Thru	Right	U	Left	Thru	Right	U		
All Vehicles	36	960	252	32	28	856	44	0	76	164	120	4	188	152	40	0	2952	
Heavy Trucks	0	0	0		0	0	0		0	0	0		0	0	0		0	
Buses	0	0	0		0	0	0		0	0	0		0	0	0		0	
Pedestrians	0	0	0		0	0	0		0	0	0		0	0	0		0	
Bicycles	0	0	0		0	0	0		0	0	0		0	0	0		0	
Scoters	0	0	0		0	0	0		0	0	0		0	0	0		0	

Comments:

**LOCATION:** Hacienda Dr -- Dublin Blvd  
**CITY/STATE:** Dublin, CA

**QC JOB #:** 16444323  
**DATE:** Thu, Jan 18 2024

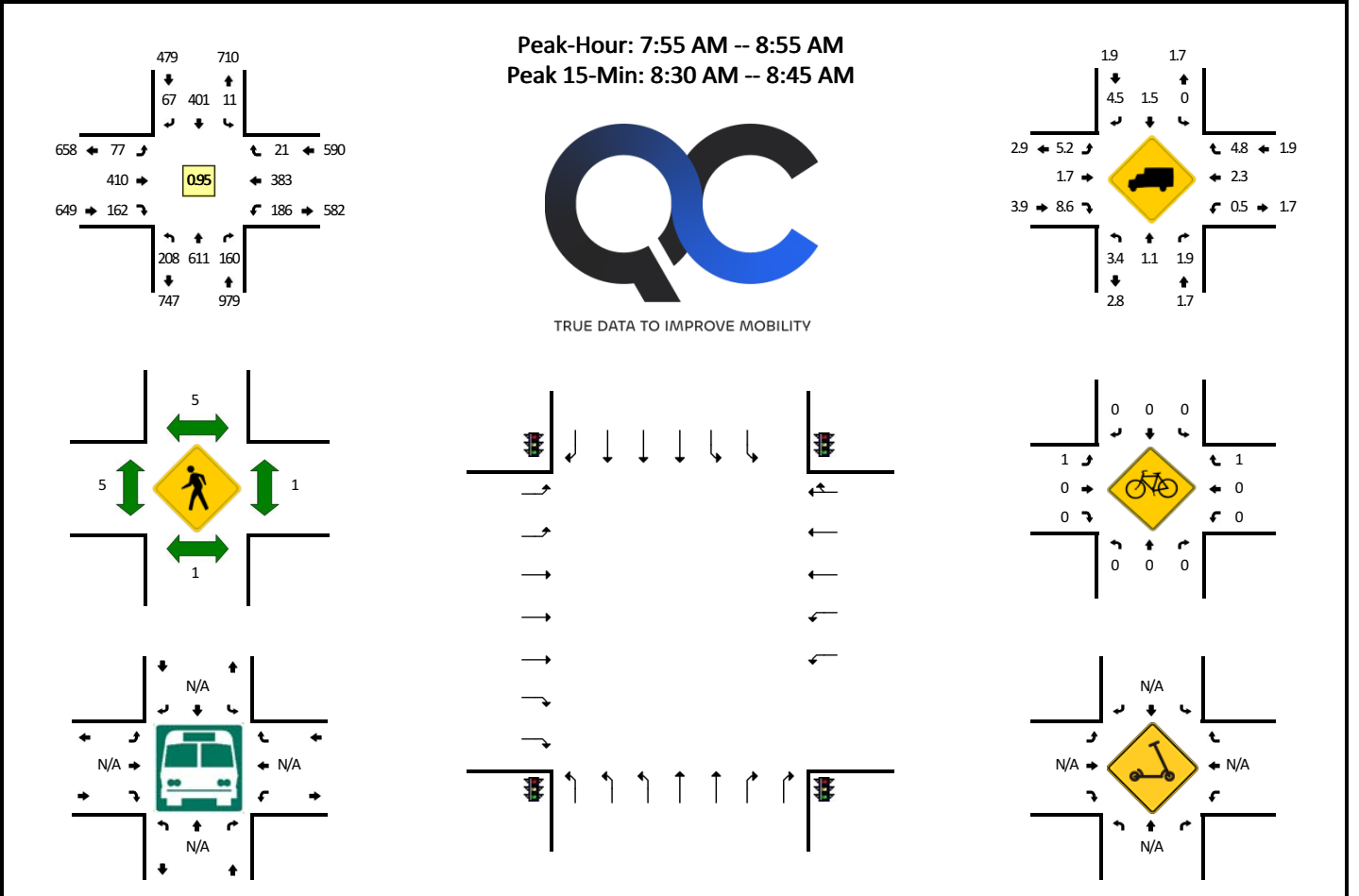

5-Min Count Period Beginning At	Hacienda Dr (Northbound)				Hacienda Dr (Southbound)				Dublin Blvd (Eastbound)				Dublin Blvd (Westbound)				Total	Hourly Totals
	Left	Thru	Right	U	Left	Thru	Right	U	Left	Thru	Right	U	Left	Thru	Right	U		
7:00 AM	9	24	5	0	0	7	0	0	0	7	8	0	8	14	1	0	83	
7:05 AM	14	20	6	0	0	13	1	0	0	12	4	0	5	16	0	0	91	
7:10 AM	16	27	6	0	0	13	4	0	0	10	9	0	10	21	1	0	121	
7:15 AM	9	24	6	0	1	12	2	0	0	15	10	0	5	13	0	0	99	
7:20 AM	9	14	7	0	1	11	2	0	0	27	9	0	13	21	0	0	115	
7:25 AM	15	29	7	2	1	16	2	0	0	16	12	0	4	12	2	0	120	
7:30 AM	13	31	6	0	1	11	3	0	0	21	8	0	12	18	0	0	129	
7:35 AM	8	36	4	0	0	16	3	0	0	9	8	0	11	20	1	0	118	
7:40 AM	15	33	6	0	1	11	6	0	0	13	14	0	11	30	3	0	144	
7:45 AM	15	52	10	0	0	23	6	0	0	11	10	0	8	21	2	0	160	
7:50 AM	19	30	8	0	1	6	5	0	0	28	14	0	4	33	1	0	151	
7:55 AM	16	60	15	0	1	42	4	0	0	25	22	0	13	35	0	0	238	1569
8:00 AM	18	49	15	0	0	26	11	0	0	22	15	0	6	46	2	0	212	1698
8:05 AM	20	40	12	0	0	37	10	0	0	44	11	0	12	28	0	2	224	1831
8:10 AM	11	38	16	0	0	36	6	0	0	51	11	0	21	49	2	0	247	1957
8:15 AM	26	44	7	0	1	44	6	0	0	25	11	0	18	29	2	0	216	2074
8:20 AM	31	57	14	0	0	43	7	0	0	19	15	0	13	25	4	0	231	2190
8:25 AM	10	49	8	0	1	24	4	0	0	33	16	0	26	44	4	0	227	2297
8:30 AM	18	78	14	0	3	46	6	0	0	43	10	0	10	16	1	0	250	2418
8:35 AM	7	40	17	0	2	19	2	1	0	45	14	0	17	34	2	0	207	2507
8:40 AM	15	64	12	0	0	38	3	0	0	41	15	0	19	36	1	0	253	2616
8:45 AM	19	49	16	0	1	17	2	0	0	36	12	0	16	22	1	0	205	2661
8:50 AM	17	43	14	0	1	29	6	0	0	26	10	0	13	19	2	0	187	2697
8:55 AM	26	45	12	0	2	23	4	0	0	28	13	0	10	34	3	0	202	2661
Peak 15-Min Flowrates	Northbound				Southbound				Eastbound				Westbound				Total	
	Left	Thru	Right	U	Left	Thru	Right	U	Left	Thru	Right	U	Left	Thru	Right	U		
All Vehicles	160	728	172	0	20	412	44	4	84	516	156	0	184	344	16	0	2840	
Heavy Trucks	12	12	4		0	8	0		8	8	20		0	16	0		88	
Buses																		
Pedestrians	0	0			0	0			0	0			0	0			0	
Bicycles	0	0			0	0			0	0			0	0	4		4	
Scooters																		

*Comments:*

**LOCATION:** Hacienda Dr -- Dublin Blvd  
**CITY/STATE:** Dublin, CA

**QC JOB #:** 16444324  
**DATE:** Thu, Jan 18 2024

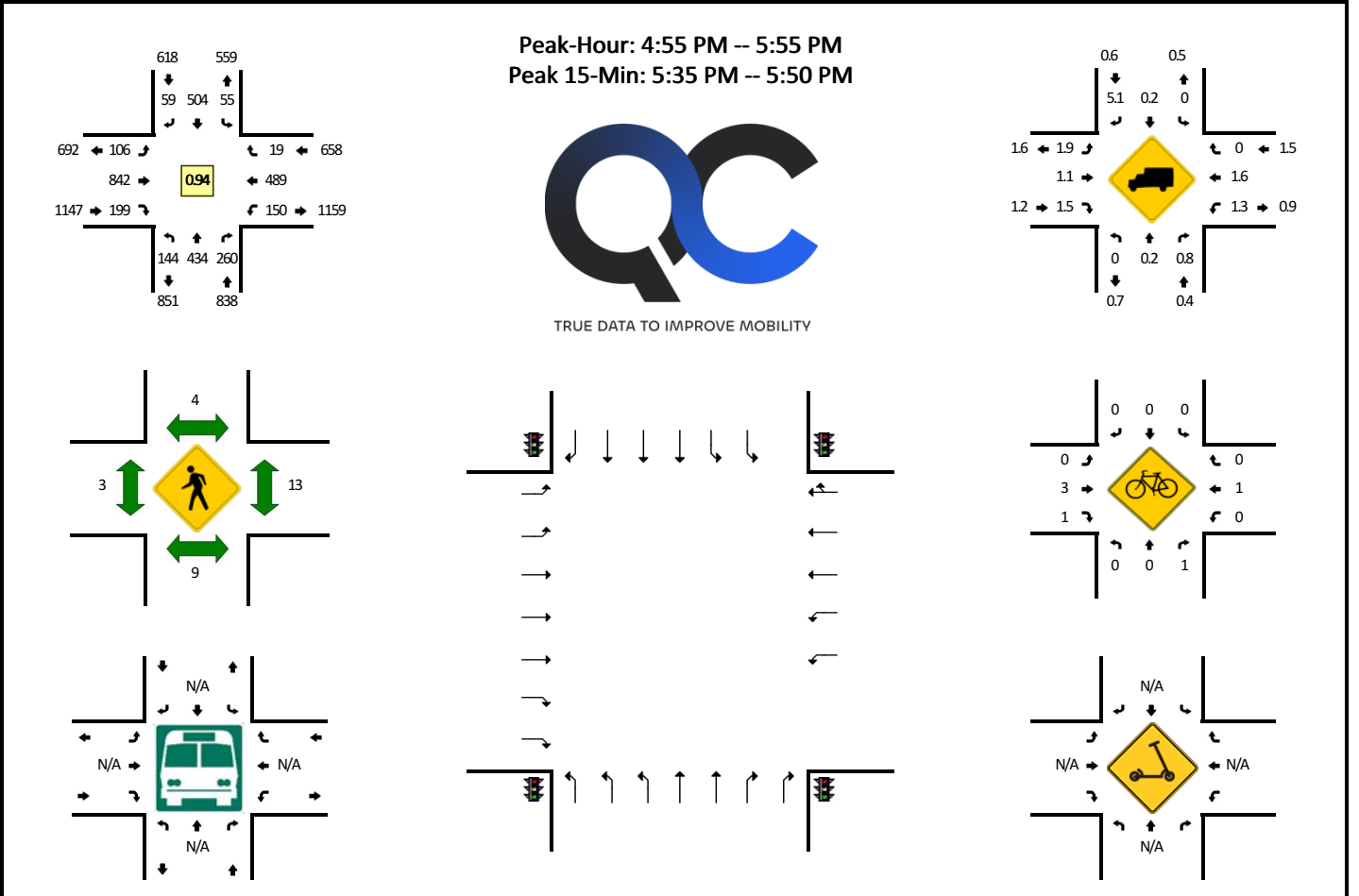

5-Min Count Period Beginning At	Hacienda Dr (Northbound)				Hacienda Dr (Southbound)				Dublin Blvd (Eastbound)				Dublin Blvd (Westbound)				Total	Hourly Totals
	Left	Thru	Right	U	Left	Thru	Right	U	Left	Thru	Right	U	Left	Thru	Right	U		
4:00 PM	9	17	19	0	6	42	1	0	16	65	17	0	10	35	3	0	240	
4:05 PM	11	38	19	0	1	45	3	0	12	70	13	0	10	34	1	0	257	
4:10 PM	12	19	17	2	6	48	4	2	17	70	22	0	7	37	1	0	264	
4:15 PM	7	20	18	0	4	24	6	0	8	109	19	0	12	30	0	0	257	
4:20 PM	6	29	12	0	1	49	3	0	11	63	11	0	5	23	1	0	214	
4:25 PM	16	16	21	0	8	22	3	0	16	99	22	0	13	40	1	0	277	
4:30 PM	11	40	17	0	2	33	7	0	15	75	23	0	9	38	0	1	271	
4:35 PM	14	23	13	0	5	40	3	0	8	56	22	0	6	19	0	0	209	
4:40 PM	14	14	23	0	4	47	6	0	10	83	16	1	13	51	2	0	284	
4:45 PM	11	38	17	0	6	67	6	0	5	80	23	0	9	29	3	0	294	
4:50 PM	17	27	20	0	5	42	4	0	15	30	18	0	17	22	1	0	218	
4:55 PM	8	24	13	0	3	31	3	0	12	72	11	0	14	50	0	1	242	3027
5:00 PM	9	35	23	0	3	59	5	0	9	52	11	0	8	54	0	0	268	3055
5:05 PM	14	35	23	0	5	53	9	0	6	62	21	0	16	19	0	1	264	3062
5:10 PM	8	25	15	0	8	41	2	0	8	69	15	0	18	36	2	0	247	3045
5:15 PM	18	49	33	0	7	64	4	0	7	54	12	0	7	38	3	0	296	3084
5:20 PM	16	36	16	0	4	40	4	0	12	64	24	0	12	49	2	0	279	3149
5:25 PM	6	26	27	0	7	32	6	0	13	87	14	0	16	38	1	0	273	3145
5:30 PM	19	34	20	0	4	34	5	0	0	63	19	0	10	32	2	0	242	3116
5:35 PM	5	45	22	0	5	31	5	0	8	91	23	0	11	45	0	0	291	3198
5:40 PM	9	41	18	0	2	53	7	0	11	73	13	0	9	46	1	0	283	3197
5:45 PM	17	49	31	0	4	39	6	0	6	71	21	0	12	28	6	0	290	3193
5:50 PM	15	35	19	0	3	27	3	0	14	84	15	0	15	54	2	0	286	3261
5:55 PM	16	37	17	0	2	30	7	0	5	53	18	0	14	33	3	0	235	3254
Peak 15-Min Flowrates	Northbound				Southbound				Eastbound				Westbound				Total	
	Left	Thru	Right	U	Left	Thru	Right	U	Left	Thru	Right	U	Left	Thru	Right	U		
All Vehicles	124	540	284	0	44	492	72	0	100	940	228	0	128	476	28	0	3456	
Heavy Trucks	0	0	0		0	0	4		4	8	4		4	12	0		36	
Buses																		
Pedestrians		12				0				0				28			40	
Bicycles		0				0				0				4	0		4	
Scooters																		

Comments:

**LOCATION:** Tassajara Rd -- I-580 WB Ramps  
**CITY/STATE:** Dublin, CA

**QC JOB #:** 16444325  
**DATE:** Thu, Jan 18 2024

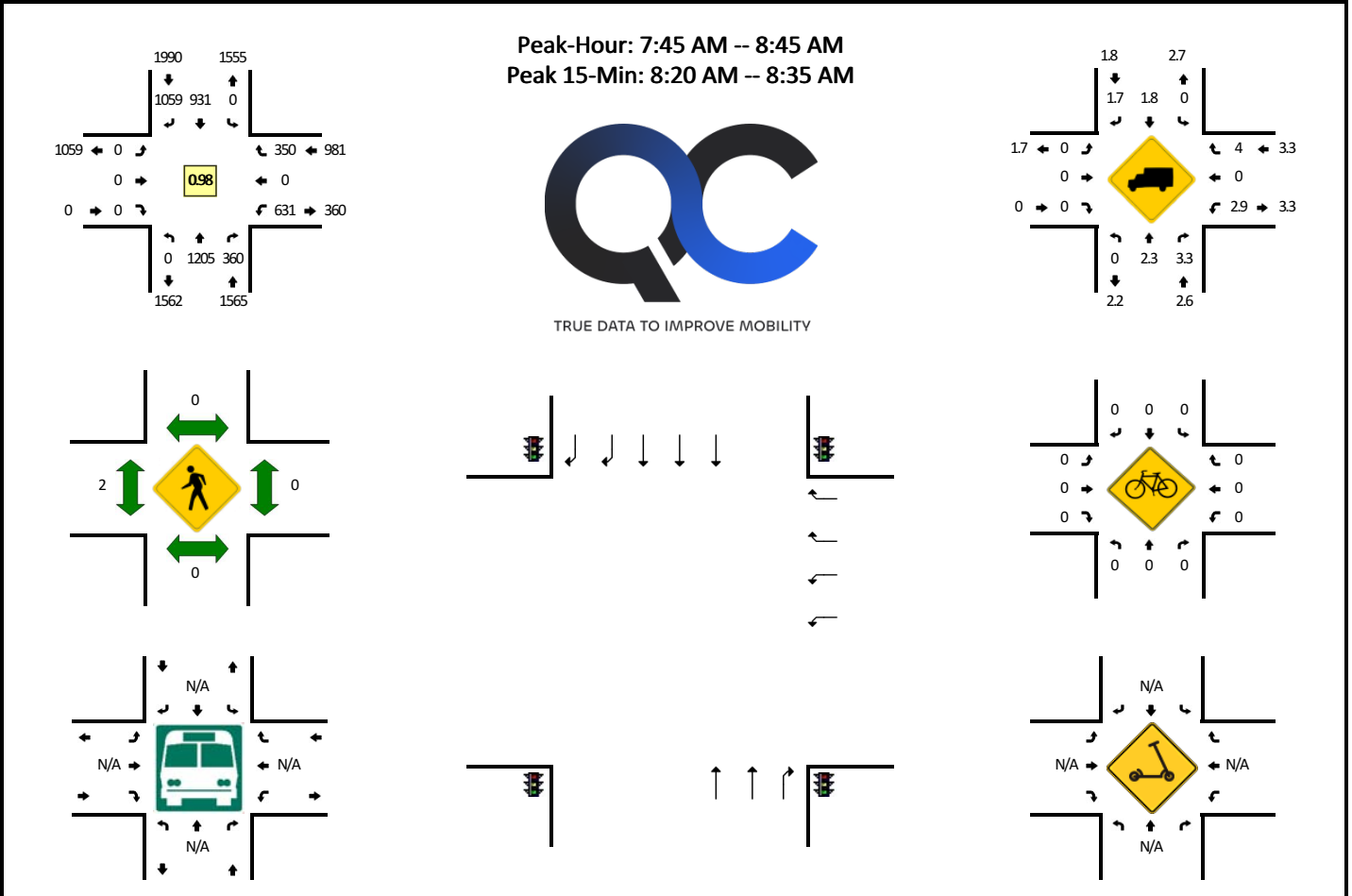

5-Min Count Period Beginning At	Tassajara Rd (Northbound)				Tassajara Rd (Southbound)				I-580 WB Ramps (Eastbound)				I-580 WB Ramps (Westbound)				Total	Hourly Totals
	Left	Thru	Right	U	Left	Thru	Right	U	Left	Thru	Right	U	Left	Thru	Right	U		
7:00 AM	0	47	29	0	0	28	40	0	0	0	0	0	30	0	17	0	191	
7:05 AM	0	50	24	0	0	36	49	0	0	0	0	0	38	0	20	0	217	
7:10 AM	0	43	24	0	0	36	40	0	0	0	0	0	45	0	21	0	209	
7:15 AM	0	57	21	0	0	28	44	0	0	0	0	0	50	0	17	0	217	
7:20 AM	0	47	27	0	0	32	37	0	0	0	0	0	53	0	25	0	221	
7:25 AM	0	64	30	0	0	51	53	0	0	0	0	0	45	0	23	0	266	
7:30 AM	0	51	30	0	0	54	50	0	0	0	0	0	32	0	32	0	249	
7:35 AM	0	96	28	0	0	42	31	0	0	0	0	0	53	0	30	0	280	
7:40 AM	0	70	36	0	0	69	53	0	0	0	0	0	44	0	35	0	307	
7:45 AM	0	108	32	0	0	61	67	0	0	0	0	0	77	0	33	0	378	
7:50 AM	0	95	29	0	0	86	89	0	0	0	0	0	60	0	36	0	395	
7:55 AM	0	109	19	0	0	62	101	0	0	0	0	0	48	0	33	0	372	3302
8:00 AM	0	97	33	0	0	63	103	0	0	0	0	0	37	0	32	0	365	3476
8:05 AM	0	98	39	0	0	59	100	0	0	0	0	0	46	0	26	0	368	3627
8:10 AM	0	79	33	0	0	88	111	0	0	0	0	0	38	0	25	0	374	3792
8:15 AM	0	104	27	0	0	84	91	0	0	0	0	0	50	0	24	0	380	3955
8:20 AM	0	104	36	0	0	91	80	0	0	0	0	0	45	0	19	0	375	4109
8:25 AM	0	111	27	0	0	96	68	0	0	0	0	0	53	0	37	0	392	4235
8:30 AM	0	86	28	0	0	81	87	0	0	0	0	0	84	0	26	0	392	4378
8:35 AM	0	110	27	0	0	77	67	0	0	0	0	0	39	0	36	0	356	4454
8:40 AM	0	104	30	0	0	83	95	0	0	0	0	0	54	0	23	0	389	4536
8:45 AM	0	131	29	0	0	67	61	0	0	0	0	0	58	0	32	0	378	4536
8:50 AM	0	113	26	0	0	77	55	0	0	0	0	0	52	0	33	0	356	4497
8:55 AM	0	110	25	0	0	86	55	0	0	0	0	0	66	0	29	0	371	4496
Peak 15-Min Flowrates	Northbound				Southbound				Eastbound				Westbound				Total	
	Left	Thru	Right	U	Left	Thru	Right	U	Left	Thru	Right	U	Left	Thru	Right	U		
All Vehicles	0	1204	364	0	0	1072	940	0	0	0	0	0	728	0	328	0	4636	
Heavy Trucks	0	28	4		0	24	28		0	0	0		16	0	16		116	
Buses																		
Pedestrians	0	0			0	0			0	0			0	0			0	
Bicycles	0	0			0	0			0	0			0	0			0	
Scoters																		

Comments:

**LOCATION:** Tassajara Rd -- I-580 WB Ramps  
**CITY/STATE:** Dublin, CA

**QC JOB #:** 16444326  
**DATE:** Thu, Jan 18 2024

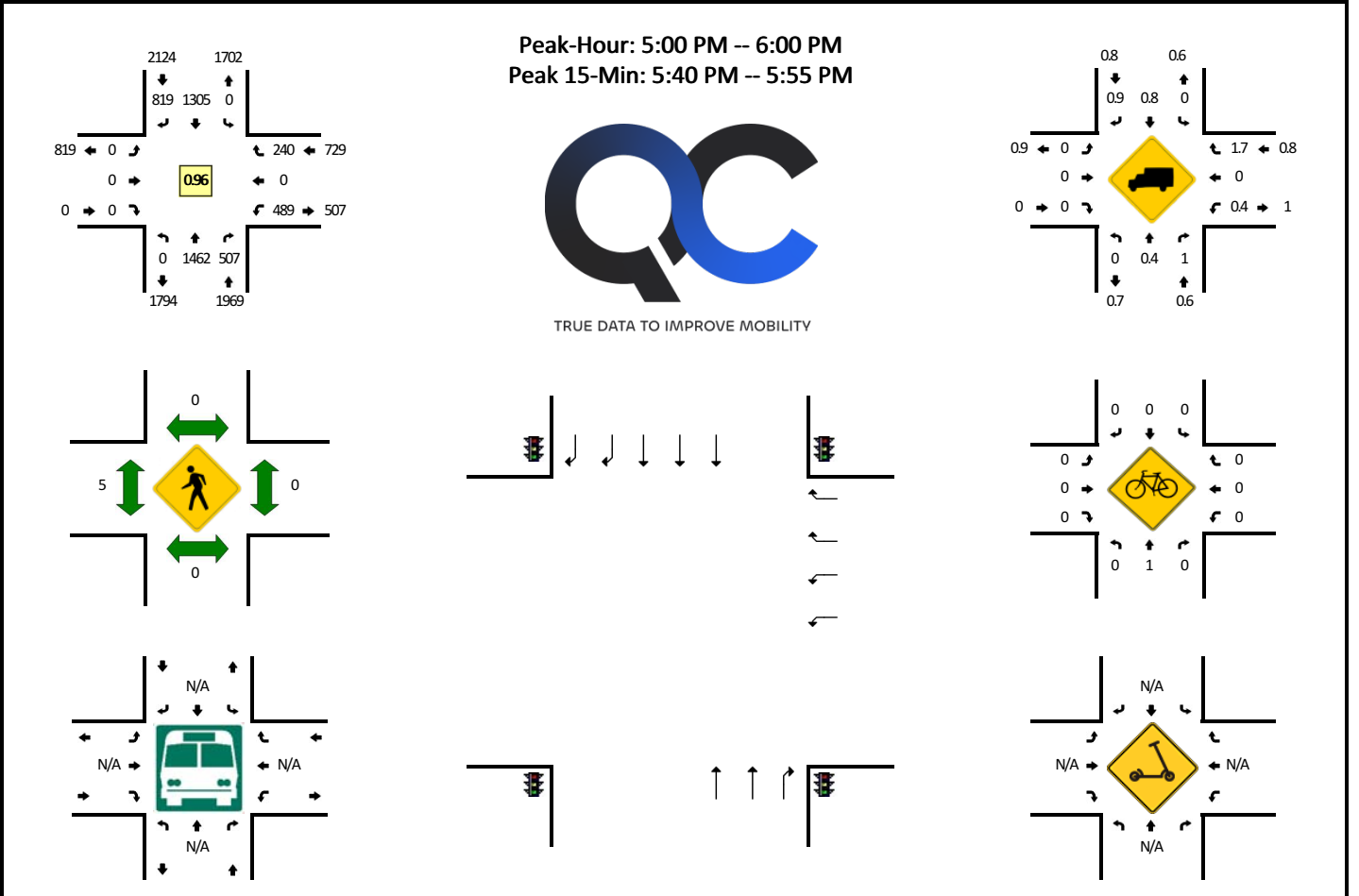

5-Min Count Period Beginning At	Tassajara Rd (Northbound)				Tassajara Rd (Southbound)				I-580 WB Ramps (Eastbound)				I-580 WB Ramps (Westbound)				Total	Hourly Totals
	Left	Thru	Right	U	Left	Thru	Right	U	Left	Thru	Right	U	Left	Thru	Right	U		
4:00 PM	0	127	44	0	0	99	52	0	0	0	0	0	32	0	16	0	370	
4:05 PM	0	79	34	0	0	119	68	0	0	0	0	0	37	0	18	0	355	
4:10 PM	0	112	51	0	0	98	65	0	0	0	0	0	47	0	21	0	394	
4:15 PM	0	92	41	0	0	119	67	0	0	0	0	0	34	0	17	0	370	
4:20 PM	0	107	47	0	0	124	87	0	0	0	0	0	48	0	26	0	439	
4:25 PM	0	98	48	0	0	103	60	0	0	0	0	0	33	0	21	0	363	
4:30 PM	0	106	79	0	0	94	51	0	0	0	0	0	39	0	15	0	384	
4:35 PM	0	93	46	0	0	116	77	0	0	0	0	0	39	0	19	0	390	
4:40 PM	0	107	61	0	0	123	73	0	0	0	0	0	35	0	9	0	408	
4:45 PM	0	106	43	0	0	112	52	0	0	0	0	0	29	0	16	0	358	
4:50 PM	0	90	32	0	0	131	64	0	0	0	0	0	40	0	20	0	377	
4:55 PM	0	103	39	0	0	103	72	0	0	0	0	0	39	0	19	0	375	4583
5:00 PM	0	115	46	0	0	110	62	0	0	0	0	0	35	0	25	0	393	4606
5:05 PM	0	103	39	0	0	121	89	0	0	0	0	0	33	0	10	0	395	4646
5:10 PM	0	112	63	0	0	123	61	0	0	0	0	0	38	0	26	0	423	4675
5:15 PM	0	121	45	0	0	112	62	0	0	0	0	0	44	0	20	0	404	4709
5:20 PM	0	118	59	0	0	110	56	0	0	0	0	0	37	0	16	0	396	4666
5:25 PM	0	111	46	0	0	99	56	0	0	0	0	0	47	0	22	0	381	4684
5:30 PM	0	106	33	0	0	113	56	0	0	0	0	0	46	0	21	0	375	4675
5:35 PM	0	136	40	0	0	102	78	0	0	0	0	0	35	0	16	0	407	4692
5:40 PM	0	144	27	0	0	103	90	0	0	0	0	0	54	0	20	0	438	4722
5:45 PM	0	121	39	0	0	109	81	0	0	0	0	0	36	0	23	0	409	4773
5:50 PM	0	144	39	0	0	110	63	0	0	0	0	0	42	0	17	0	415	4811
5:55 PM	0	131	31	0	0	93	65	0	0	0	0	0	42	0	24	0	386	4822
Peak 15-Min Flowrates	Northbound				Southbound				Eastbound				Westbound				Total	
	Left	Thru	Right	U	Left	Thru	Right	U	Left	Thru	Right	U	Left	Thru	Right	U		
All Vehicles	0	1636	420	0	0	1288	936	0	0	0	0	0	528	0	240	0	5048	
Heavy Trucks	0	12	4		0	0	4		0	0	0		0	0	0		20	
Buses																		
Pedestrians	0	0			0	0			4				0	0			4	
Bicycles	0	0			0	0			0	0	0		0	0			0	
Scoters																		

Comments:



**LOCATION:** Fallon Rd -- Positano Pkwy  
**CITY/STATE:** Dublin, CA

**QC JOB #:** 16444329  
**DATE:** Wed, Jan 10 2024

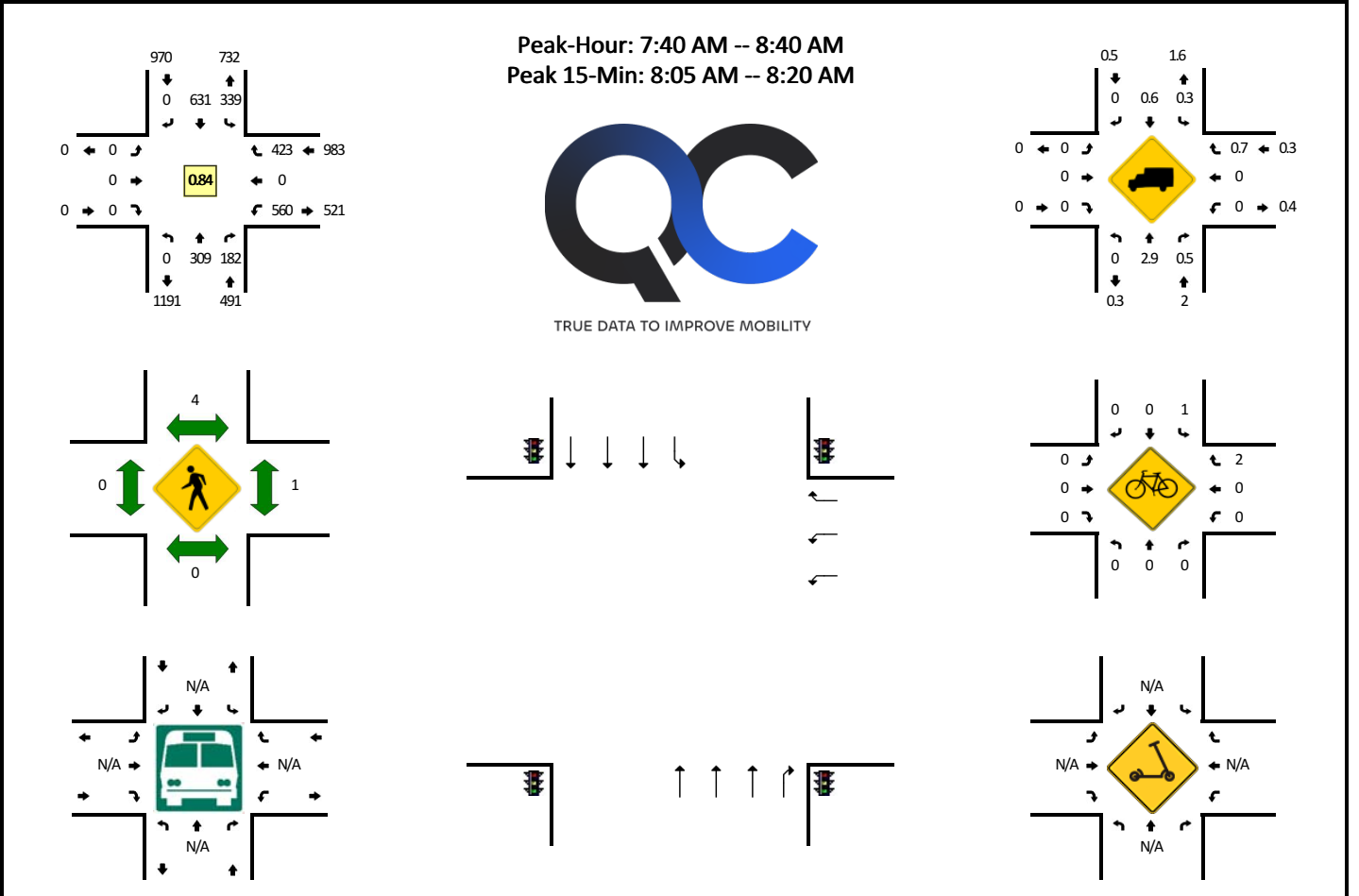

5-Min Count Period Beginning At	Fallon Rd (Northbound)				Fallon Rd (Southbound)				Positano Pkwy (Eastbound)				Positano Pkwy (Westbound)				Total	Hourly Totals
	Left	Thru	Right	U	Left	Thru	Right	U	Left	Thru	Right	U	Left	Thru	Right	U		
7:00 AM	0	11	1	0	1	12	0	0	0	0	0	0	12	0	1	0	38	
7:05 AM	0	8	2	0	1	17	0	0	0	0	0	0	8	0	0	0	36	
7:10 AM	0	11	8	0	2	16	0	0	0	0	0	0	22	0	5	0	64	
7:15 AM	0	17	12	0	2	19	0	0	0	0	0	0	17	0	3	0	70	
7:20 AM	0	28	9	0	4	16	0	0	0	0	0	0	21	0	4	0	82	
7:25 AM	0	25	8	0	6	20	0	0	0	0	0	0	9	0	4	0	72	
7:30 AM	0	11	5	0	2	26	0	0	0	0	0	0	22	0	12	0	78	
7:35 AM	0	21	13	0	14	31	0	0	0	0	0	0	28	0	10	0	117	
7:40 AM	0	25	12	0	23	35	0	0	0	0	0	0	21	0	11	0	127	
7:45 AM	0	13	14	0	41	42	0	0	0	0	0	0	31	0	20	0	161	
7:50 AM	0	26	20	0	31	48	0	0	0	0	0	0	58	0	14	0	197	
7:55 AM	0	30	14	0	29	73	0	0	0	0	0	0	52	0	31	0	229	1271
8:00 AM	0	22	11	0	41	84	0	0	0	0	0	0	39	0	27	0	224	1457
8:05 AM	0	28	18	0	36	78	0	0	0	0	0	0	46	0	68	0	274	1695
8:10 AM	0	26	19	0	27	40	0	0	0	0	0	0	41	0	68	0	221	1852
8:15 AM	0	31	19	0	28	49	0	0	0	0	0	0	58	0	51	0	236	2018
8:20 AM	0	30	15	0	30	49	0	0	0	0	0	0	54	0	47	0	225	2161
8:25 AM	0	26	12	0	25	57	0	0	0	0	0	0	60	0	42	0	222	2311
8:30 AM	0	26	10	0	18	42	0	0	0	0	0	0	66	0	38	0	200	2433
8:35 AM	0	26	18	0	10	34	0	0	0	0	0	0	34	0	6	0	128	2444
8:40 AM	0	18	16	0	7	25	0	0	0	0	0	0	37	0	6	0	109	2426
8:45 AM	0	28	16	0	6	30	0	0	0	0	0	0	31	0	12	0	123	2388
8:50 AM	0	25	27	0	5	29	0	0	0	0	0	0	25	0	14	0	125	2316
8:55 AM	0	23	23	0	14	23	0	0	0	0	0	0	24	0	10	0	117	2204
Peak 15-Min Flowrates	Northbound				Southbound				Eastbound				Westbound				Total	
	Left	Thru	Right	U	Left	Thru	Right	U	Left	Thru	Right	U	Left	Thru	Right	U		
All Vehicles	0	340	224	0	364	668	0	0	0	0	0	0	580	0	748	0	2924	
Heavy Trucks	0	4	0		0	0	0		0	0	0		0	0	8		12	
Buses																		
Pedestrians	0	0			0	0			0	0			0	0			0	
Bicycles	0	0			0	0			0	0			0	0	4		4	
Scoters																		

Comments:

**LOCATION:** Fallon Rd -- Positano Pkwy  
**CITY/STATE:** Dublin, CA

**QC JOB #:** 16444330  
**DATE:** Wed, Jan 10 2024

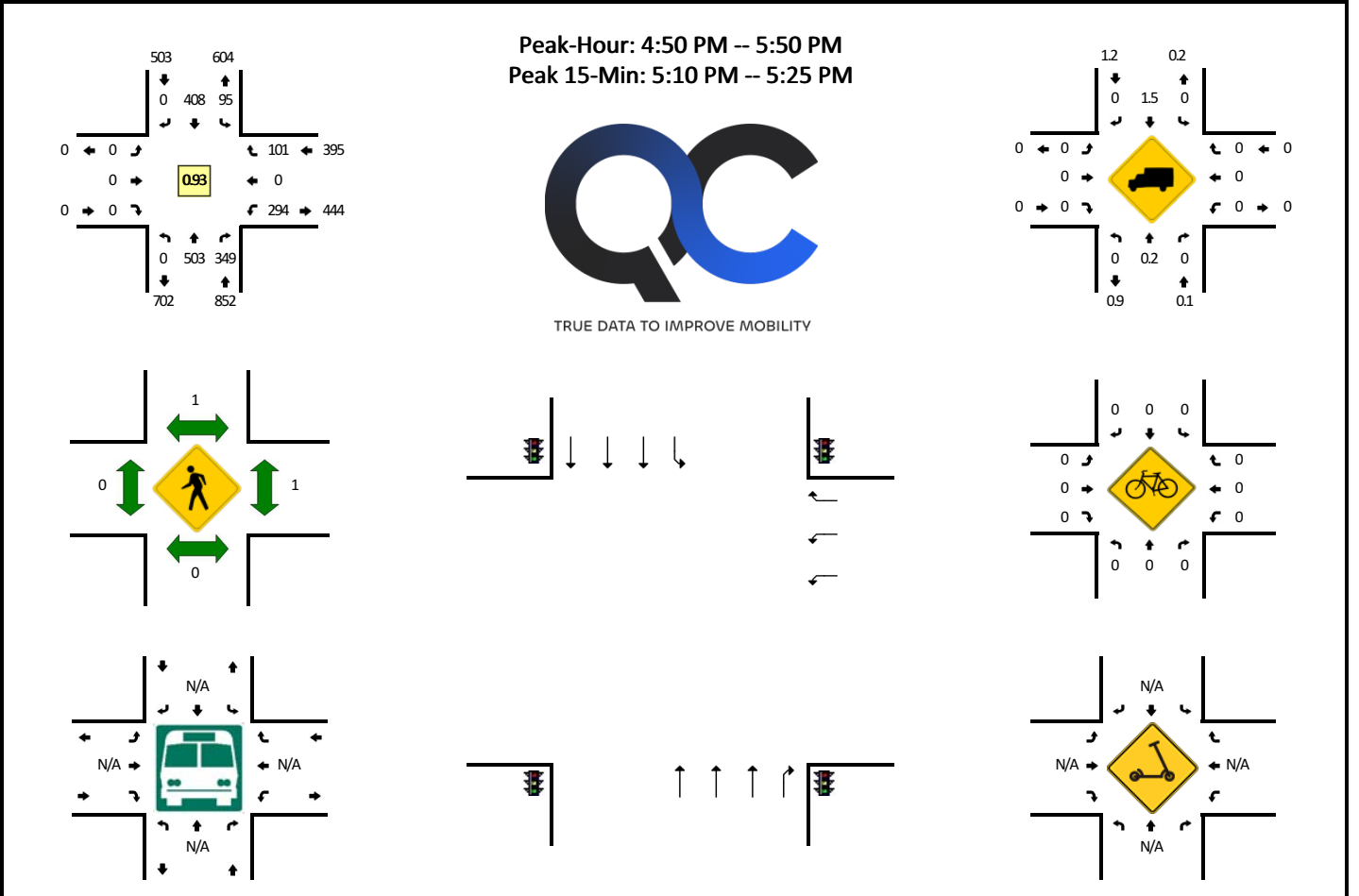

5-Min Count Period Beginning At	Fallon Rd (Northbound)				Fallon Rd (Southbound)				Positano Pkwy (Eastbound)				Positano Pkwy (Westbound)				Total	Hourly Totals
	Left	Thru	Right	U	Left	Thru	Right	U	Left	Thru	Right	U	Left	Thru	Right	U		
4:00 PM	0	34	22	0	8	35	0	0	0	0	0	0	22	0	2	0	123	
4:05 PM	0	20	17	0	9	42	0	0	0	0	0	0	27	0	5	0	120	
4:10 PM	0	30	19	0	10	32	0	0	0	0	0	0	25	0	5	0	121	
4:15 PM	0	32	17	0	7	38	0	0	0	0	0	0	23	0	3	0	120	
4:20 PM	0	27	19	0	6	35	0	0	0	0	0	0	13	0	5	0	105	
4:25 PM	0	26	20	0	6	31	0	0	0	0	0	0	13	0	6	0	102	
4:30 PM	0	37	27	0	6	37	0	0	0	0	0	0	23	0	3	0	133	
4:35 PM	0	24	27	0	8	37	0	0	0	0	0	0	25	0	11	0	132	
4:40 PM	0	38	20	0	11	33	0	0	0	0	0	0	26	0	8	0	136	
4:45 PM	0	28	26	0	14	34	0	0	0	0	0	0	26	0	7	0	135	
4:50 PM	0	35	24	0	6	47	0	0	0	0	0	0	25	0	5	0	142	
4:55 PM	0	32	20	0	6	30	0	0	0	0	0	0	28	0	13	0	129	1498
5:00 PM	0	41	30	0	6	34	0	0	0	0	0	0	23	0	6	0	140	1515
5:05 PM	0	42	24	0	9	30	0	0	0	0	0	0	21	0	11	0	137	1532
5:10 PM	0	40	49	0	4	35	0	0	0	0	0	0	28	0	13	0	169	1580
5:15 PM	0	34	26	0	8	31	0	0	0	0	0	0	20	0	7	0	126	1586
5:20 PM	0	49	45	0	11	42	0	0	0	0	0	0	24	0	4	0	175	1656
5:25 PM	0	47	24	0	6	32	0	0	0	0	0	0	22	0	13	0	144	1698
5:30 PM	0	45	32	0	4	24	0	0	0	0	0	0	16	0	5	0	126	1691
5:35 PM	0	56	25	0	11	28	0	0	0	0	0	0	36	0	6	0	162	1721
5:40 PM	0	34	22	0	14	36	0	0	0	0	0	0	28	0	10	0	144	1729
5:45 PM	0	48	28	0	10	39	0	0	0	0	0	0	23	0	8	0	156	1750
5:50 PM	0	41	23	0	7	25	0	0	0	0	0	0	20	0	8	0	124	1732
5:55 PM	0	35	21	0	14	29	0	0	0	0	0	0	22	0	5	0	126	1729
Peak 15-Min Flowrates	Northbound				Southbound				Eastbound				Westbound				Total	
	Left	Thru	Right	U	Left	Thru	Right	U	Left	Thru	Right	U	Left	Thru	Right	U		
All Vehicles	0	492	480	0	92	432	0	0	0	0	0	0	288	0	96	0	1880	
Heavy Trucks	0	0	0	0	0	4	0	0	0	0	0	0	0	0	0	0	4	
Buses	0	0	0	0	0	0	0	0	0	0	0	0	0	0	0	0	0	
Pedestrians	0	0	0	0	0	0	0	0	0	0	0	0	0	0	0	0	0	
Bicycles	0	0	0	0	0	0	0	0	0	0	0	0	0	0	0	0	0	
Scoters	0	0	0	0	0	0	0	0	0	0	0	0	0	0	0	0	0	

Comments:

**LOCATION:** Fallon Rd -- Tassajara Rd/Syrah Dr  
**CITY/STATE:** Dublin, CA

**QC JOB #:** 16444331  
**DATE:** Wed, Jan 10 2024

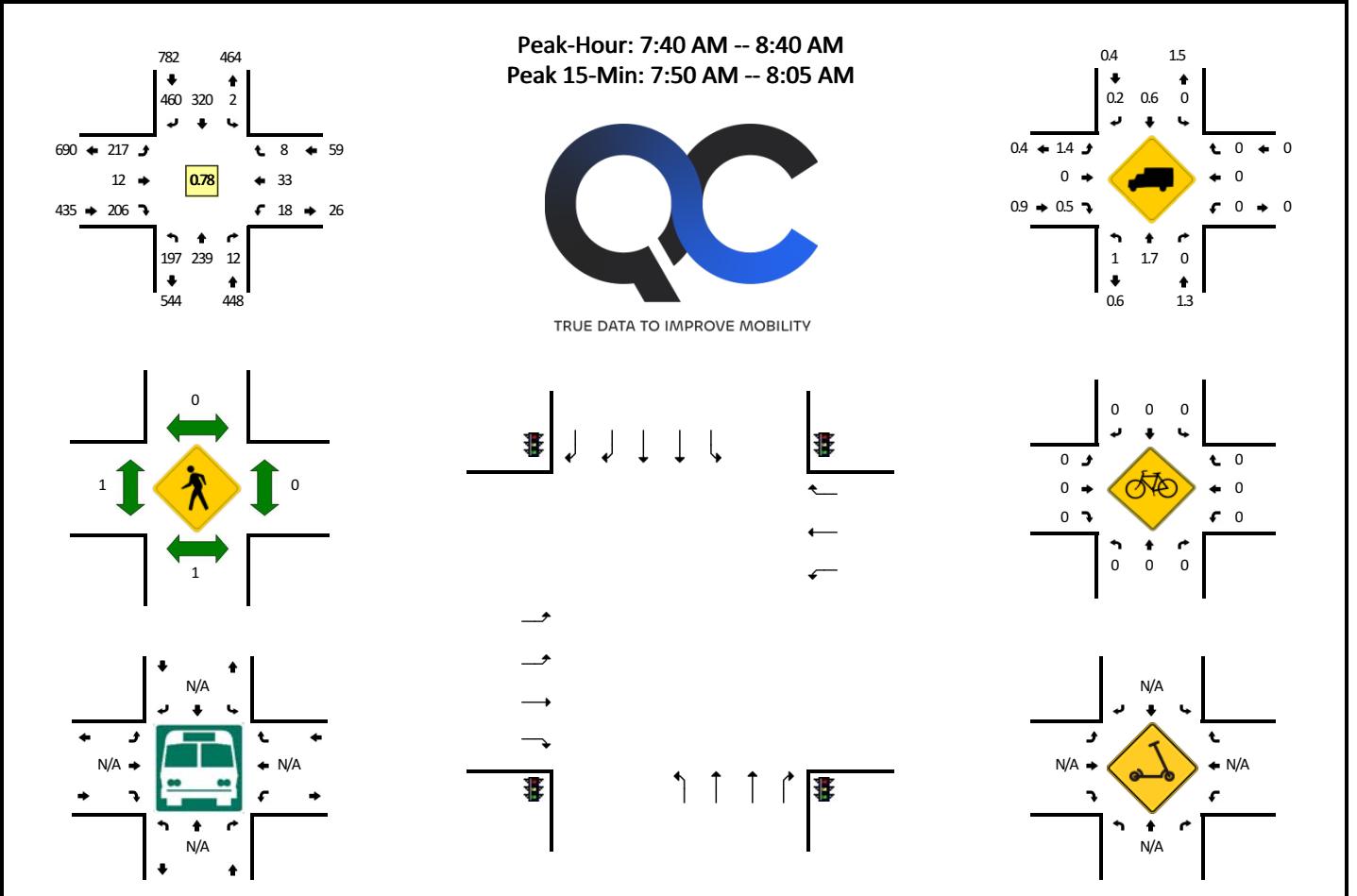

5-Min Count Period Beginning At	Fallon Rd (Northbound)				Fallon Rd (Southbound)				Tassajara Rd/Syrah Dr (Eastbound)				Tassajara Rd/Syrah Dr (Westbound)				Total	Hourly Totals
	Left	Thru	Right	U	Left	Thru	Right	U	Left	Thru	Right	U	Left	Thru	Right	U		
7:00 AM	0	6	1	0	0	5	12	0	10	0	1	0	0	2	0	0	37	
7:05 AM	0	12	0	0	0	6	15	0	7	0	1	0	0	1	0	0	42	
7:10 AM	0	8	0	0	0	15	17	0	8	1	0	0	0	0	0	0	49	
7:15 AM	0	6	0	0	0	7	25	0	7	1	1	0	0	3	1	0	51	
7:20 AM	1	20	0	0	1	12	15	0	12	0	2	0	0	3	0	0	66	
7:25 AM	0	18	0	0	0	13	25	0	15	1	2	0	0	3	0	0	77	
7:30 AM	2	17	0	0	0	21	32	0	11	0	7	0	0	1	0	0	91	
7:35 AM	2	13	0	0	0	12	27	0	20	2	13	0	0	2	0	0	91	
7:40 AM	4	14	0	0	0	36	27	0	17	0	14	0	0	2	0	0	114	
7:45 AM	10	11	0	0	0	26	40	0	13	2	29	0	4	0	0	0	135	
7:50 AM	11	8	0	0	0	44	45	0	14	1	42	0	3	5	1	0	174	
7:55 AM	14	16	0	0	1	37	50	0	16	1	54	0	4	2	1	0	196	1123
8:00 AM	13	15	2	0	0	42	58	0	25	3	20	0	2	5	1	0	186	1272
8:05 AM	7	13	1	0	1	26	43	0	16	1	15	0	1	3	1	0	128	1358
8:10 AM	29	24	0	0	0	21	35	0	15	0	11	0	3	4	0	0	142	1451
8:15 AM	17	23	3	0	0	20	43	0	16	1	5	0	0	2	0	0	130	1530
8:20 AM	24	31	4	0	0	18	31	0	26	2	4	0	1	2	2	0	145	1609
8:25 AM	29	33	1	0	0	21	41	0	17	1	6	0	0	1	2	0	152	1684
8:30 AM	20	19	0	0	0	11	24	0	26	0	3	0	0	3	0	0	106	1699
8:35 AM	19	32	1	0	0	18	23	0	16	0	3	0	0	4	0	0	116	1724
8:40 AM	4	13	0	0	0	7	44	0	18	0	4	0	0	2	0	0	92	1702
8:45 AM	4	15	0	0	0	11	46	0	25	0	3	0	0	0	0	0	104	1671
8:50 AM	8	22	0	0	0	22	36	0	13	1	2	0	0	4	0	0	108	1605
8:55 AM	6	21	0	0	2	15	40	0	24	2	8	0	0	0	0	0	118	1527
Peak 15-Min Flowrates	Northbound				Southbound				Eastbound				Westbound				Total	
	Left	Thru	Right	U	Left	Thru	Right	U	Left	Thru	Right	U	Left	Thru	Right	U		
All Vehicles	152	156	8	0	4	492	612	0	220	20	464	0	36	48	12	0	2224	
Heavy Trucks	0	4	0	0	0	0	0	0	4	0	0	0	0	0	0	0	8	
Buses	0	0	0	0	0	0	0	0	0	0	0	0	0	0	0	0	0	
Pedestrians	0	0	0	0	0	0	0	0	0	0	0	0	0	0	0	0	0	
Bicycles	0	0	0	0	0	0	0	0	0	0	0	0	0	0	0	0	0	
Scoters	0	0	0	0	0	0	0	0	0	0	0	0	0	0	0	0	0	

Comments:

**LOCATION:** Fallon Rd -- Tassajara Rd/Syrah Dr  
**CITY/STATE:** Dublin, CA

**QC JOB #:** 16444332  
**DATE:** Wed, Jan 10 2024

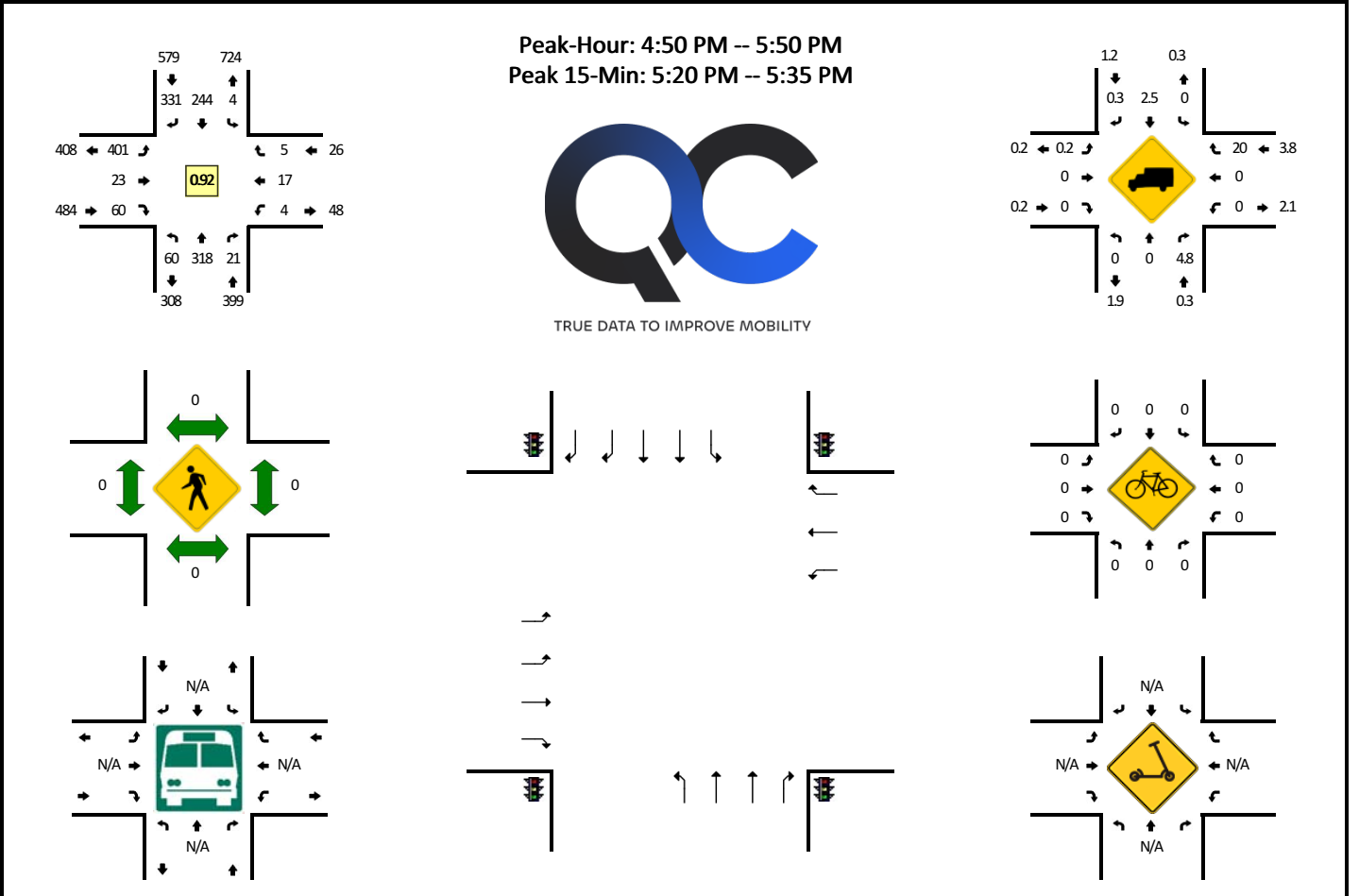

5-Min Count Period Beginning At	Fallon Rd (Northbound)				Fallon Rd (Southbound)				Tassajara Rd/Syrah Dr (Eastbound)				Tassajara Rd/Syrah Dr (Westbound)				Total	Hourly Totals	
	Left	Thru	Right	U	Left	Thru	Right	U	Left	Thru	Right	U	Left	Thru	Right	U			
4:00 PM	9	15	2	0	0	23	33	0	23	0	5	0	0	2	0	0	0	112	
4:05 PM	11	13	0	0	0	19	24	0	46	2	15	0	0	4	0	0	0	134	
4:10 PM	6	18	0	0	2	27	29	0	41	3	8	0	0	4	1	0	0	139	
4:15 PM	8	17	0	0	1	26	28	0	31	4	8	0	0	3	1	0	0	127	
4:20 PM	3	19	1	0	0	17	20	0	44	0	6	0	1	2	0	0	0	113	
4:25 PM	5	14	0	0	0	25	17	0	20	0	6	0	0	1	0	0	0	88	
4:30 PM	7	22	0	0	0	26	37	0	25	2	1	0	0	0	0	0	0	120	
4:35 PM	3	22	0	0	0	25	19	0	32	1	6	0	0	0	0	0	0	108	
4:40 PM	6	25	0	0	0	15	27	0	31	3	6	0	0	2	0	0	0	115	
4:45 PM	1	15	0	0	0	31	37	0	13	1	2	0	0	2	0	0	0	102	
4:50 PM	1	23	3	0	0	23	39	0	31	2	4	0	1	0	0	0	0	127	
4:55 PM	7	31	1	0	0	25	40	0	25	3	4	0	0	3	1	0	0	140	1425
5:00 PM	6	17	0	0	1	20	8	0	26	1	3	0	0	2	0	0	0	84	1397
5:05 PM	1	28	0	0	0	12	26	0	37	2	6	0	0	0	0	0	0	112	1375
5:10 PM	5	22	3	0	1	16	23	0	41	1	7	0	0	0	0	0	0	119	1355
5:15 PM	6	21	1	0	1	22	27	0	16	2	4	0	0	3	1	0	0	104	1332
5:20 PM	5	30	1	0	0	17	31	0	37	3	10	0	0	1	1	0	0	136	1355
5:25 PM	6	30	1	0	0	17	34	0	48	1	3	0	1	1	0	0	0	142	1409
5:30 PM	5	33	6	0	0	16	28	0	28	2	4	0	0	2	1	0	0	125	1414
5:35 PM	9	33	3	0	0	23	20	0	34	0	5	0	0	1	0	0	0	128	1434
5:40 PM	6	28	1	0	0	27	28	0	39	4	9	0	1	4	1	0	0	148	1467
5:45 PM	3	22	1	0	1	26	27	0	39	2	1	0	1	0	0	0	0	123	1488
5:50 PM	7	27	2	0	0	17	28	0	27	1	4	0	3	1	0	0	0	117	1478
5:55 PM	5	20	4	0	0	13	21	0	35	4	6	0	1	2	0	0	0	111	1449
Peak 15-Min Flowrates	Northbound				Southbound				Eastbound				Westbound				Total		
	Left	Thru	Right	U	Left	Thru	Right	U	Left	Thru	Right	U	Left	Thru	Right	U			
All Vehicles	64	372	32	0	0	200	372	0	452	24	68	0	4	16	8	0	0	1612	
Heavy Trucks	0	0	4	0	0	16	0	0	0	0	0	0	0	0	4	0	0	24	
Buses	0	0	0	0	0	0	0	0	0	0	0	0	0	0	0	0	0	0	
Pedestrians	0	0	0	0	0	0	0	0	0	0	0	0	0	0	0	0	0	0	
Bicycles	0	0	0	0	0	0	0	0	0	0	0	0	0	0	0	0	0	0	
Scoters	0	0	0	0	0	0	0	0	0	0	0	0	0	0	0	0	0	0	

*Comments:*

**LOCATION:** El Charro Rd -- Stoneridge Dr/Jack London Blvd  
**CITY/STATE:** Pleasanton, CA

**QC JOB #:** 16444333  
**DATE:** Thu, Jan 18 2024

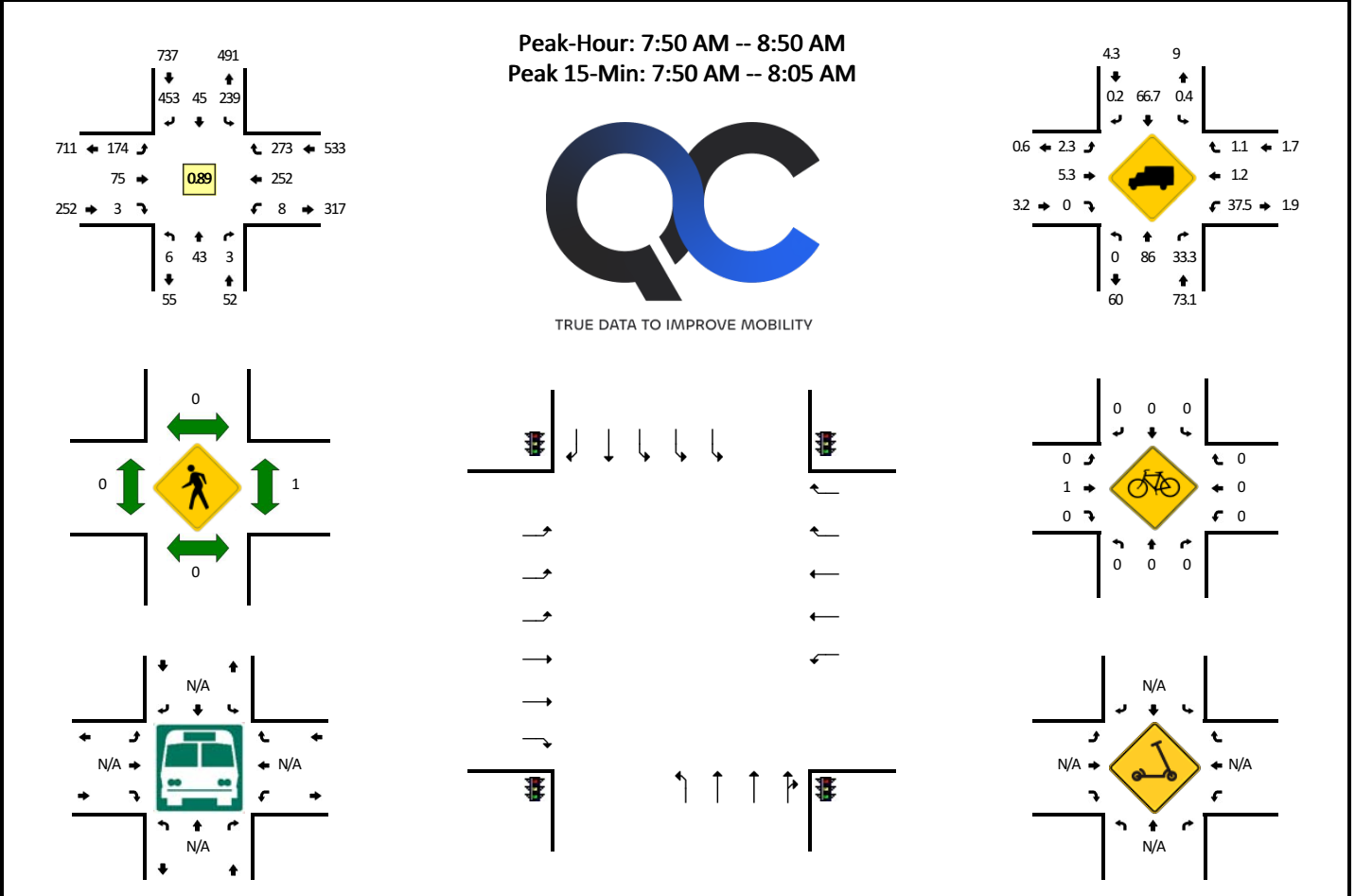

5-Min Count Period Beginning At	El Charro Rd (Northbound)				El Charro Rd (Southbound)				Stoneridge Dr/Jack London Blvd (Eastbound)				Stoneridge Dr/Jack London Blvd (Westbound)				Total	Hourly Totals
	Left	Thru	Right	U	Left	Thru	Right	U	Left	Thru	Right	U	Left	Thru	Right	U		
7:00 AM	0	3	1	0	15	3	6	0	6	3	0	0	0	10	9	0	56	
7:05 AM	2	1	0	0	12	4	10	0	7	4	0	0	0	6	11	0	57	
7:10 AM	1	2	0	0	5	3	8	0	5	2	0	0	0	6	11	0	43	
7:15 AM	0	5	0	0	9	7	18	0	7	1	1	0	0	12	11	0	71	
7:20 AM	0	5	0	0	3	4	18	0	7	2	0	0	0	10	16	0	65	
7:25 AM	1	3	2	0	7	2	20	1	7	1	1	0	2	13	25	0	85	
7:30 AM	0	1	0	0	12	5	29	0	12	6	0	0	0	21	18	0	104	
7:35 AM	0	6	0	0	12	3	26	0	9	3	0	0	0	13	30	0	102	
7:40 AM	0	4	1	0	17	5	26	0	8	7	0	0	0	20	18	0	106	
7:45 AM	1	1	1	0	13	6	31	0	7	7	0	0	0	18	23	0	108	
7:50 AM	0	2	0	0	16	3	42	0	9	3	1	0	0	24	35	1	136	
7:55 AM	0	5	1	0	19	1	43	0	16	9	0	0	1	18	33	0	146	1079
8:00 AM	0	2	0	0	22	3	52	0	19	7	0	0	0	34	19	0	158	1181
8:05 AM	1	7	1	0	15	1	30	0	17	5	1	0	1	18	29	0	126	1250
8:10 AM	0	4	0	0	19	8	43	0	16	13	0	0	1	20	27	0	151	1358
8:15 AM	1	4	0	0	18	8	35	0	14	3	1	0	0	14	18	0	116	1403
8:20 AM	1	3	0	0	18	4	32	0	15	4	0	0	2	18	19	0	116	1454
8:25 AM	1	2	0	0	21	1	45	0	10	6	0	0	0	20	18	0	124	1493
8:30 AM	0	2	1	0	19	2	27	0	15	10	0	0	1	19	23	0	119	1508
8:35 AM	1	1	0	0	20	1	38	1	8	4	0	0	1	23	23	0	121	1527
8:40 AM	0	5	0	0	21	5	32	0	10	6	0	0	0	23	17	0	119	1540
8:45 AM	1	6	0	0	30	8	34	0	25	5	0	0	0	21	12	0	142	1574
8:50 AM	0	6	0	0	21	5	20	0	15	8	1	0	0	14	26	0	116	1554
8:55 AM	1	5	1	0	31	3	26	0	10	8	0	0	0	15	23	0	123	1531
Peak 15-Min Flowrates	Northbound				Southbound				Eastbound				Westbound				Total	
	Left	Thru	Right	U	Left	Thru	Right	U	Left	Thru	Right	U	Left	Thru	Right	U		
All Vehicles	0	36	4	0	228	28	548	0	176	76	4	0	4	304	348	4	1760	
Heavy Trucks	0	36	0	0	4	12	0	0	8	4	0	0	0	4	0	0	68	
Buses																		
Pedestrians	0	0	0	0	0	0	0	0	0	0	0	0	0	4	0	0	4	
Bicycles	0	0	0	0	0	0	0	0	0	0	0	0	0	0	0	0	0	
Scoters																		

*Comments:*



**LOCATION:** El Charro Rd -- Stoneridge Dr/Jack London Blvd  
**CITY/STATE:** Pleasanton, CA

**QC JOB #:** 16444334  
**DATE:** Thu, Jan 18 2024

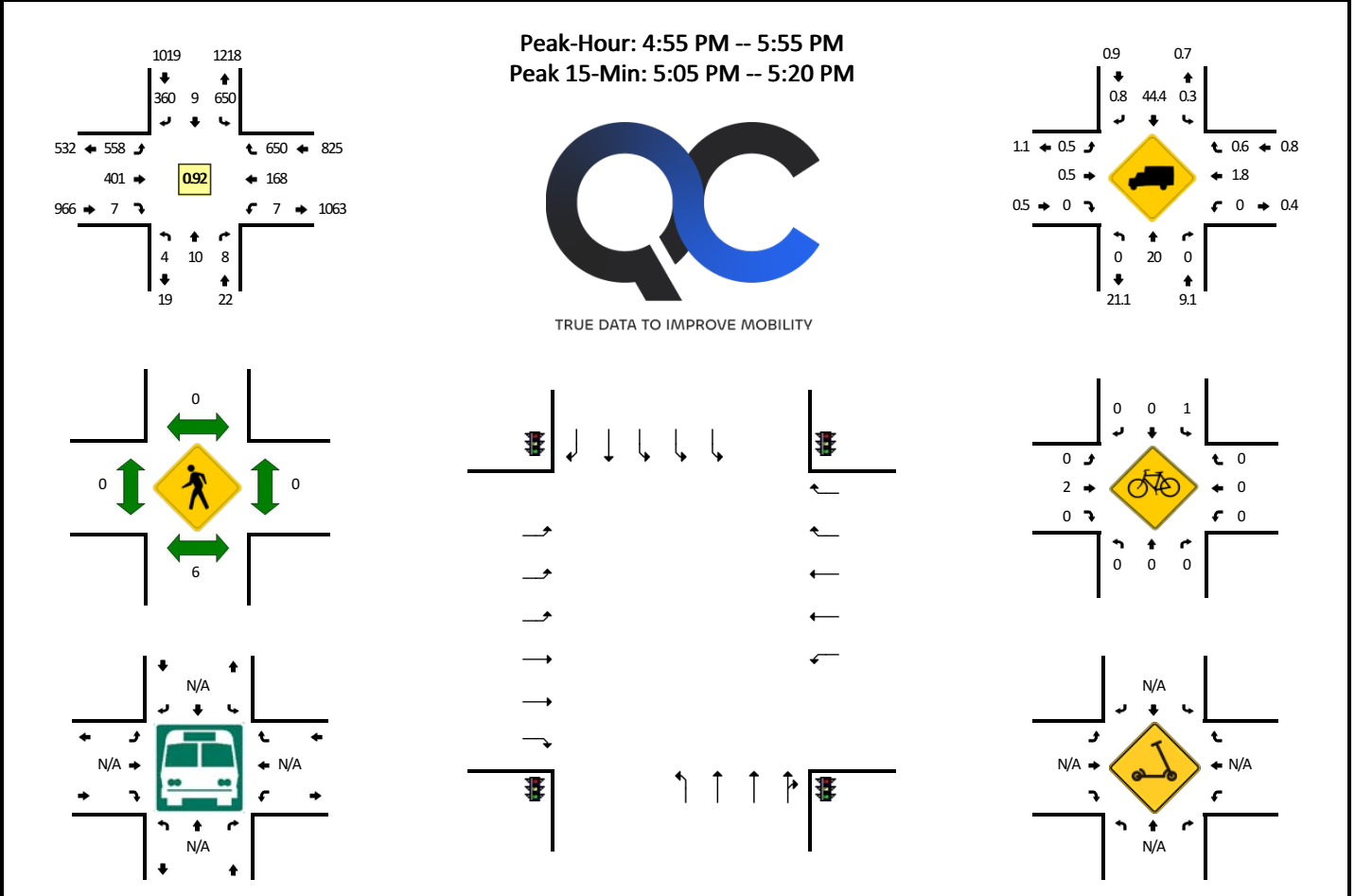

5-Min Count Period Beginning At	El Charro Rd (Northbound)				El Charro Rd (Southbound)				Stoneridge Dr/Jack London Blvd (Eastbound)				Stoneridge Dr/Jack London Blvd (Westbound)				Total	Hourly Totals
	Left	Thru	Right	U	Left	Thru	Right	U	Left	Thru	Right	U	Left	Thru	Right	U		
4:00 PM	0	2	1	0	53	0	18	0	29	19	1	0	0	16	48	1	188	
4:05 PM	1	1	1	0	51	1	15	0	36	34	0	0	1	23	67	0	231	
4:10 PM	2	0	1	0	54	2	25	0	34	29	0	0	0	16	69	0	232	
4:15 PM	0	3	1	0	66	2	24	1	35	31	0	0	0	11	41	0	215	
4:20 PM	0	0	0	0	63	2	19	0	44	31	0	0	0	20	56	0	235	
4:25 PM	0	2	0	0	47	1	27	0	35	42	1	0	0	9	54	0	218	
4:30 PM	1	1	0	0	49	0	22	0	17	27	1	0	0	18	40	1	177	
4:35 PM	0	2	0	0	53	0	19	0	49	34	0	0	0	25	57	0	239	
4:40 PM	1	3	1	0	72	4	24	0	41	31	1	0	1	14	55	0	248	
4:45 PM	1	4	1	0	40	0	19	0	42	28	0	0	0	8	50	0	193	
4:50 PM	0	1	0	0	40	0	27	0	41	30	0	0	0	18	54	0	211	
4:55 PM	0	2	0	0	84	0	28	0	30	32	1	0	1	11	44	1	234	2621
5:00 PM	0	1	1	0	48	1	35	0	39	32	0	0	0	17	48	0	222	2655
5:05 PM	1	0	1	0	46	2	22	0	50	33	0	0	0	13	71	0	239	2663
5:10 PM	0	0	1	0	53	0	28	0	56	44	1	0	0	18	65	0	266	2697
5:15 PM	0	3	0	0	76	0	37	0	40	37	0	0	0	5	65	0	263	2745
5:20 PM	0	0	0	0	46	0	31	0	54	42	1	0	0	15	45	0	234	2744
5:25 PM	0	1	0	0	49	0	33	0	56	39	3	0	0	16	50	3	250	2776
5:30 PM	1	1	3	0	54	1	22	0	40	16	1	0	1	15	58	0	213	2812
5:35 PM	1	2	0	0	37	2	32	0	52	39	0	0	0	10	40	0	215	2788
5:40 PM	0	0	1	0	56	1	38	0	47	28	0	0	1	14	51	0	237	2777
5:45 PM	1	0	0	0	45	0	25	0	49	28	0	0	0	19	58	0	225	2809
5:50 PM	0	0	1	0	56	2	29	0	45	31	0	0	0	15	55	0	234	2832
5:55 PM	1	2	0	0	39	0	23	0	40	19	0	0	0	9	42	0	175	2773
Peak 15-Min Flowrates	Northbound				Southbound				Eastbound				Westbound				Total	
	Left	Thru	Right	U	Left	Thru	Right	U	Left	Thru	Right	U	Left	Thru	Right	U		
All Vehicles	4	12	8	0	700	8	348	0	584	456	4	0	0	144	804	0	3072	
Heavy Trucks	0	0	0	0	4	4	4	0	4	4	0	0	0	0	8	0	28	
Buses																		
Pedestrians		0				0				0				0			0	
Bicycles	0	0	0		0	0	0		0	4	0		0	0	0		4	
Scoters																		

*Comments:*





**LOCATION:** Sunset View Dr -- Central Pkwy  
**CITY/STATE:** Dublin, CA

**QC JOB #:** 16444335  
**DATE:** Wed, Jan 10 2024

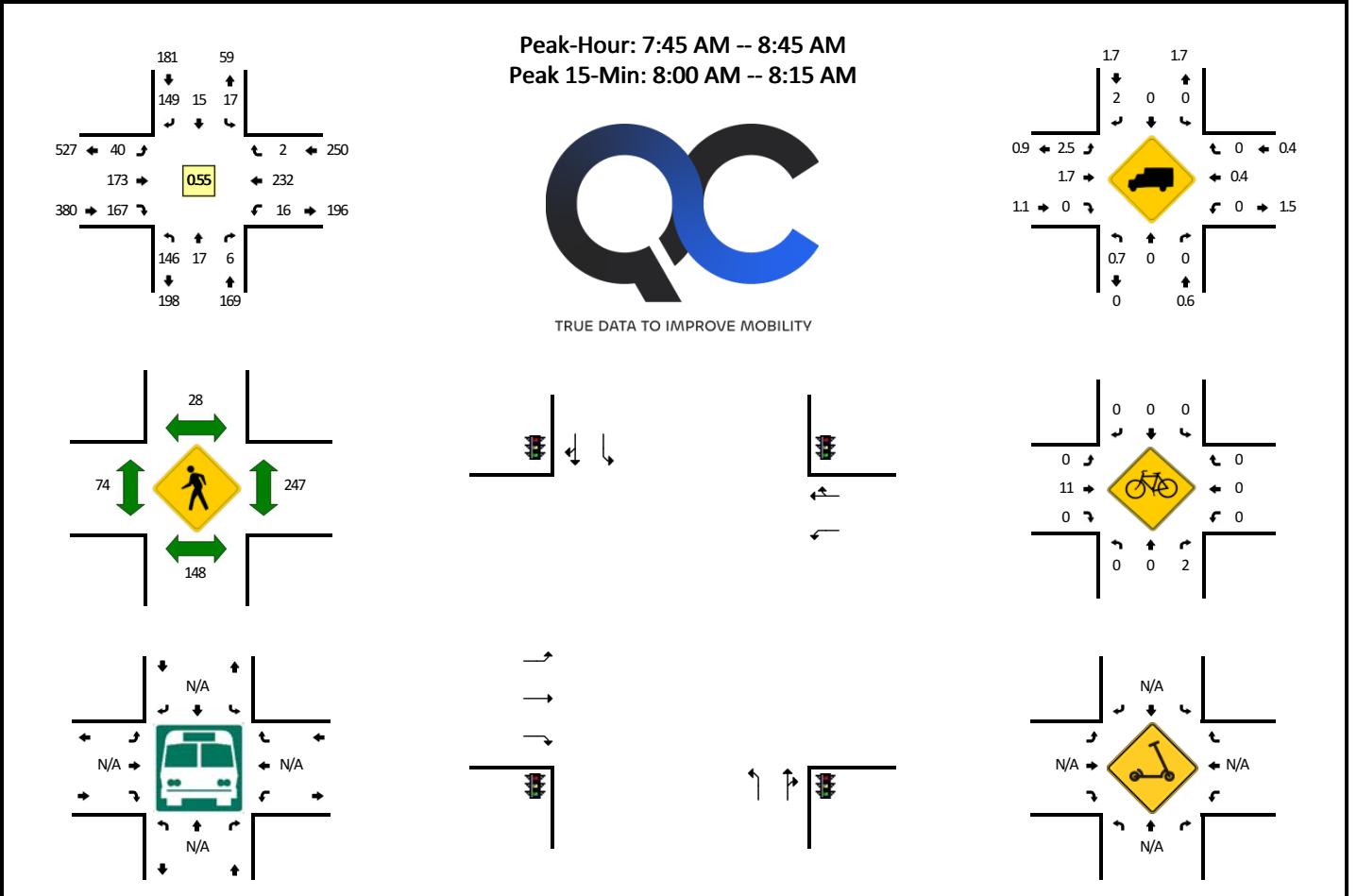

5-Min Count Period Beginning At	Sunset View Dr (Northbound)				Sunset View Dr (Southbound)				Central Pkwy (Eastbound)				Central Pkwy (Westbound)				Total	Hourly Totals
	Left	Thru	Right	U	Left	Thru	Right	U	Left	Thru	Right	U	Left	Thru	Right	U		
7:00 AM	0	0	0	0	0	0	0	0	0	2	1	0	0	6	0	0	9	
7:05 AM	4	1	0	0	0	3	4	0	0	1	6	0	0	3	0	0	24	
7:10 AM	6	3	2	0	0	2	0	0	0	0	11	0	0	2	0	0	30	
7:15 AM	19	8	3	0	0	8	2	0	0	3	18	0	0	4	0	0	68	
7:20 AM	0	0	0	0	0	0	4	0	0	1	3	0	0	5	0	0	14	
7:25 AM	0	0	0	0	0	1	2	0	0	2	2	0	0	4	0	0	11	
7:30 AM	1	0	1	0	0	0	6	0	0	4	5	0	0	3	0	0	21	
7:35 AM	0	0	0	0	0	0	4	0	0	2	8	0	0	5	1	0	21	
7:40 AM	0	0	0	0	0	0	5	0	0	5	10	0	0	9	0	0	29	
7:45 AM	1	0	0	0	1	1	9	0	4	11	9	0	0	5	0	0	41	
7:50 AM	11	0	1	0	1	0	7	0	6	26	29	0	3	13	0	0	97	
7:55 AM	30	1	1	0	2	3	6	0	2	24	41	0	3	14	0	0	127	492
8:00 AM	28	7	1	0	4	7	7	0	2	22	20	0	7	21	0	0	126	609
8:05 AM	25	5	1	0	3	3	15	0	4	44	39	0	2	31	1	0	173	758
8:10 AM	36	4	1	0	4	0	17	0	6	26	20	0	0	29	0	0	143	871
8:15 AM	9	0	1	0	1	0	38	0	4	5	4	0	0	48	0	0	110	913
8:20 AM	3	0	0	0	0	0	8	0	4	2	1	0	0	23	1	0	42	941
8:25 AM	1	0	0	0	1	1	11	0	1	3	1	0	0	13	0	0	32	962
8:30 AM	0	0	0	0	0	0	8	0	1	3	2	0	0	13	0	0	27	968
8:35 AM	2	0	0	0	0	0	9	0	2	4	1	0	0	11	0	0	29	976
8:40 AM	0	0	0	0	0	0	14	0	4	3	0	0	1	11	0	0	33	980
8:45 AM	2	0	0	0	0	0	10	0	3	3	0	0	0	10	0	0	28	967
8:50 AM	1	0	0	0	0	0	9	0	10	10	3	0	0	12	0	0	45	915
8:55 AM	1	0	0	0	0	0	3	0	5	7	0	0	0	7	0	0	23	811
Peak 15-Min Flowrates	Northbound				Southbound				Eastbound				Westbound				Total	
	Left	Thru	Right	U	Left	Thru	Right	U	Left	Thru	Right	U	Left	Thru	Right	U		
All Vehicles	356	64	12	0	44	40	156	0	48	368	316	0	36	324	4	0	1768	
Heavy Trucks	0	0	0	0	0	0	12	0	0	4	0	0	0	0	0	0	16	
Buses																		
Pedestrians		484				72				252				796			1604	
Bicycles		0	0			0	0			44	0			0	0		44	
Scoters																		

Comments:

**LOCATION:** Sunset View Dr -- Central Pkwy  
**CITY/STATE:** Dublin, CA

**QC JOB #:** 16444336  
**DATE:** Wed, Jan 10 2024

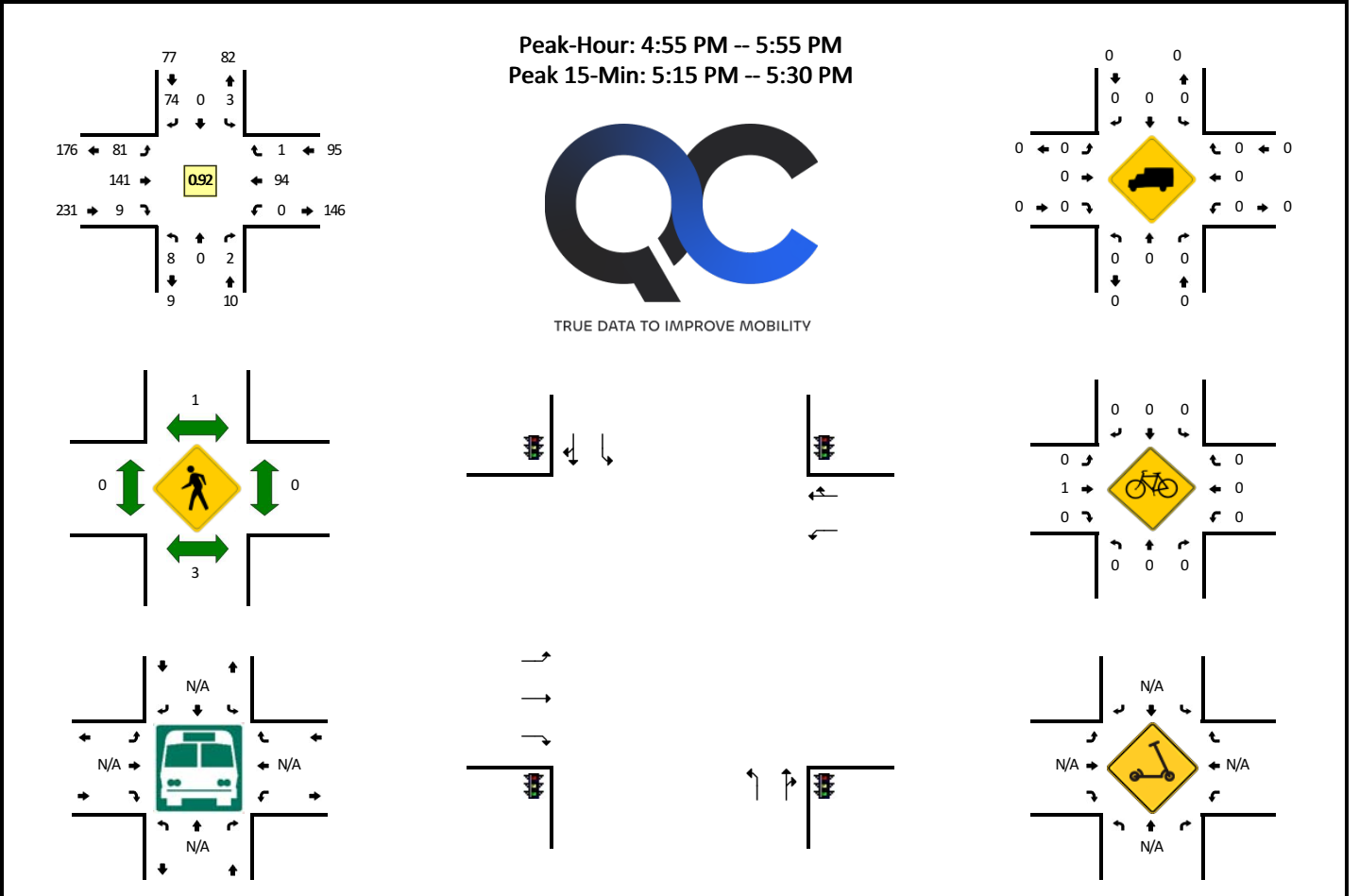

5-Min Count Period Beginning At	Sunset View Dr (Northbound)				Sunset View Dr (Southbound)				Central Pkwy (Eastbound)				Central Pkwy (Westbound)				Total	Hourly Totals	
	Left	Thru	Right	U	Left	Thru	Right	U	Left	Thru	Right	U	Left	Thru	Right	U			
4:00 PM	3	0	0	0	0	0	7	0	1	9	1	0	0	4	0	0	0	25	
4:05 PM	3	0	0	0	0	0	0	0	4	7	0	0	0	4	0	0	0	18	
4:10 PM	0	0	0	0	0	0	3	0	7	8	0	0	0	5	0	0	0	23	
4:15 PM	0	0	1	0	0	0	1	0	4	3	0	0	0	10	0	0	0	19	
4:20 PM	0	0	0	0	0	0	7	0	9	7	1	0	0	3	0	0	0	27	
4:25 PM	0	0	1	0	1	0	5	0	5	7	0	0	0	7	0	0	0	26	
4:30 PM	0	0	0	0	1	0	4	0	6	5	0	0	0	8	0	0	0	24	
4:35 PM	0	0	0	0	0	0	2	0	6	11	0	0	0	11	0	0	0	30	
4:40 PM	2	0	0	0	0	0	1	0	4	8	1	0	0	9	0	0	0	25	
4:45 PM	2	0	0	0	1	0	5	0	7	11	2	0	0	9	0	0	0	37	
4:50 PM	0	0	0	0	0	0	3	0	6	12	1	0	0	6	0	0	0	28	
4:55 PM	0	0	1	0	0	0	4	0	6	14	0	0	0	11	0	0	0	36	318
5:00 PM	0	0	0	0	0	0	12	0	5	13	1	0	0	10	0	0	0	41	334
5:05 PM	1	0	1	0	1	0	4	0	2	8	1	0	0	9	0	0	0	27	343
5:10 PM	1	0	0	0	0	0	10	0	8	12	0	0	0	6	0	0	0	37	357
5:15 PM	0	0	0	0	0	0	11	0	4	13	0	0	0	7	1	0	0	36	374
5:20 PM	1	0	0	0	0	0	2	0	6	15	1	0	0	9	0	0	0	34	381
5:25 PM	1	0	0	0	0	0	5	0	13	13	2	0	0	8	0	0	0	42	397
5:30 PM	1	0	0	0	0	0	13	0	9	6	1	0	0	6	0	0	0	36	409
5:35 PM	2	0	0	0	0	0	2	0	7	5	2	0	0	5	0	0	0	23	402
5:40 PM	0	0	0	0	0	0	5	0	4	12	1	0	0	8	0	0	0	30	407
5:45 PM	1	0	0	0	2	0	4	0	9	19	0	0	0	6	0	0	0	41	411
5:50 PM	0	0	0	0	0	0	2	0	8	11	0	0	0	9	0	0	0	30	413
5:55 PM	1	0	0	0	1	0	8	0	5	11	1	0	0	6	1	0	0	34	411
Peak 15-Min Flowrates	Northbound				Southbound				Eastbound				Westbound				Total		
All Vehicles	8	0	0	0	0	0	72	0	92	164	12	0	0	96	4	0	448		
Heavy Trucks	0	0	0	0	0	0	0	0	0	0	0	0	0	0	0	0	0		
Buses																			
Pedestrians		4				4				0				0			8		
Bicycles	0	0	0		0	0	0		0	0	0		0	0	0		0		
Scoters																			

*Comments:*



## Appendix B: Existing Volume & Geometry

Lane Configuration and Traffic Control

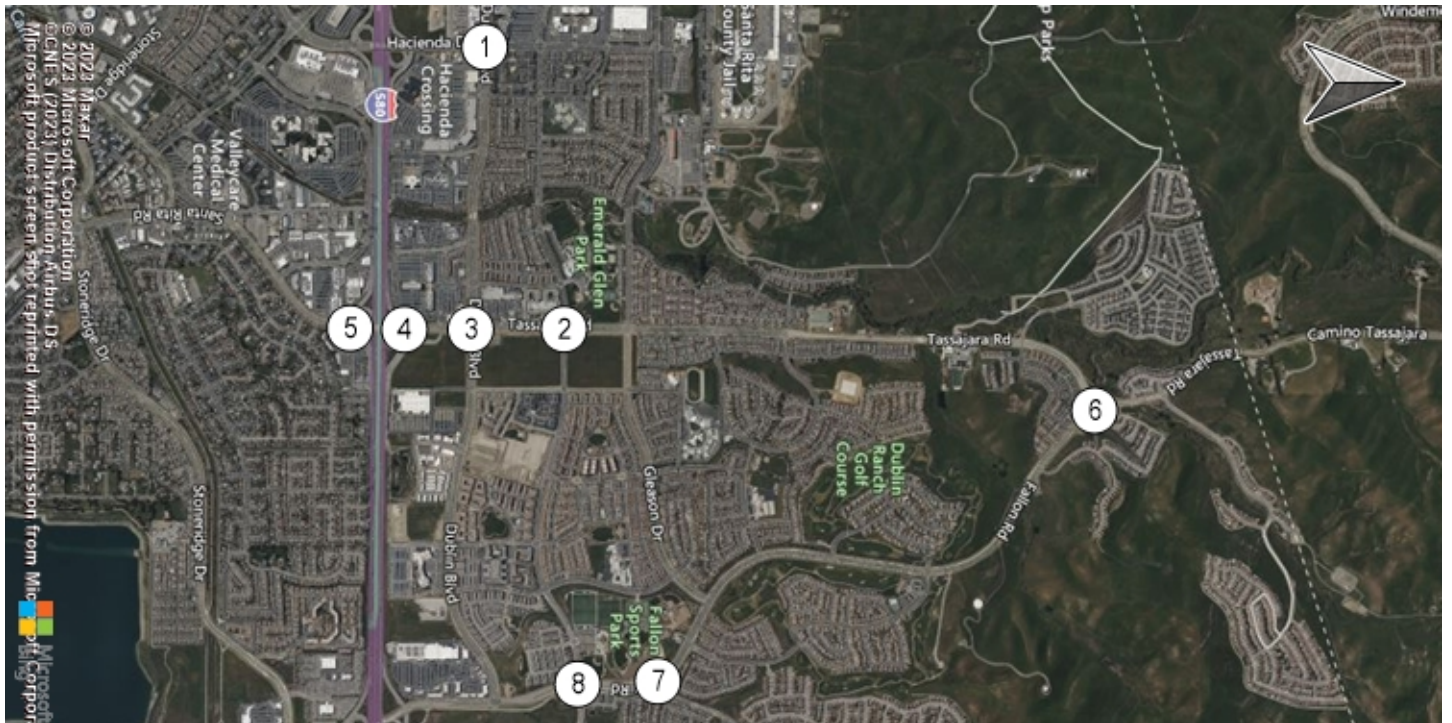

Hacienda Drive & Dublin Boulevard Tassajara Road & Central Parkway Tassajara Road & Dublin Boulevard Tassajara Road & I-580 WB

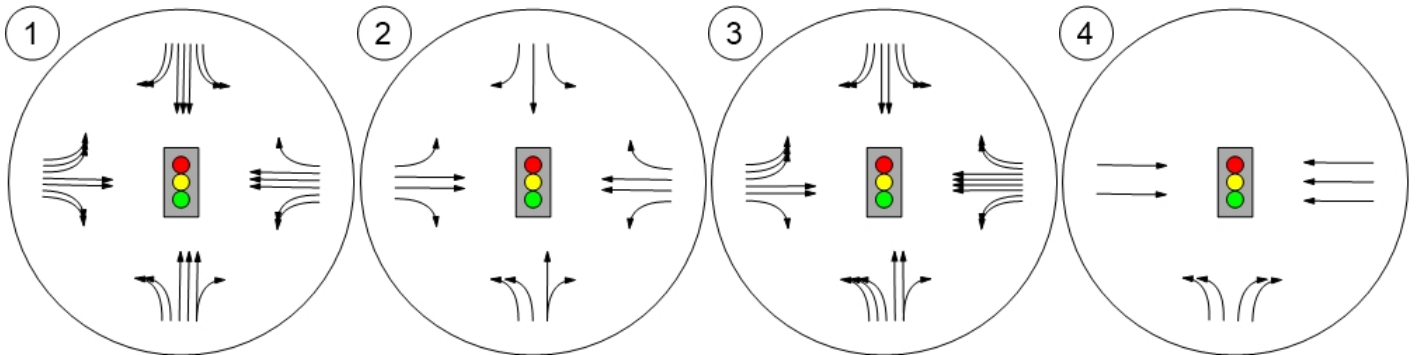

Santa Rita Road & I-580 EB R Tassajara Road & Fallon Road Fallon Road & Positano Park Fallon Road & Central Parkway

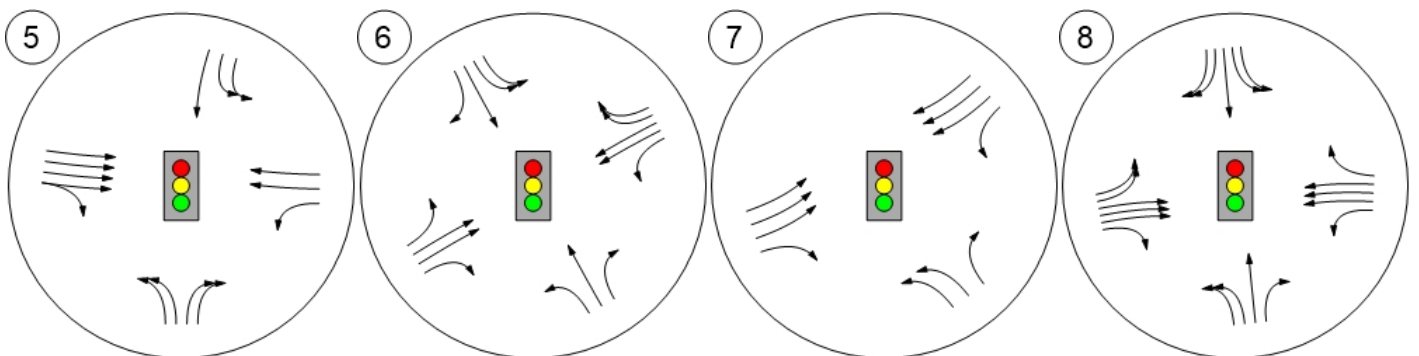



Lane Configuration and Traffic Control

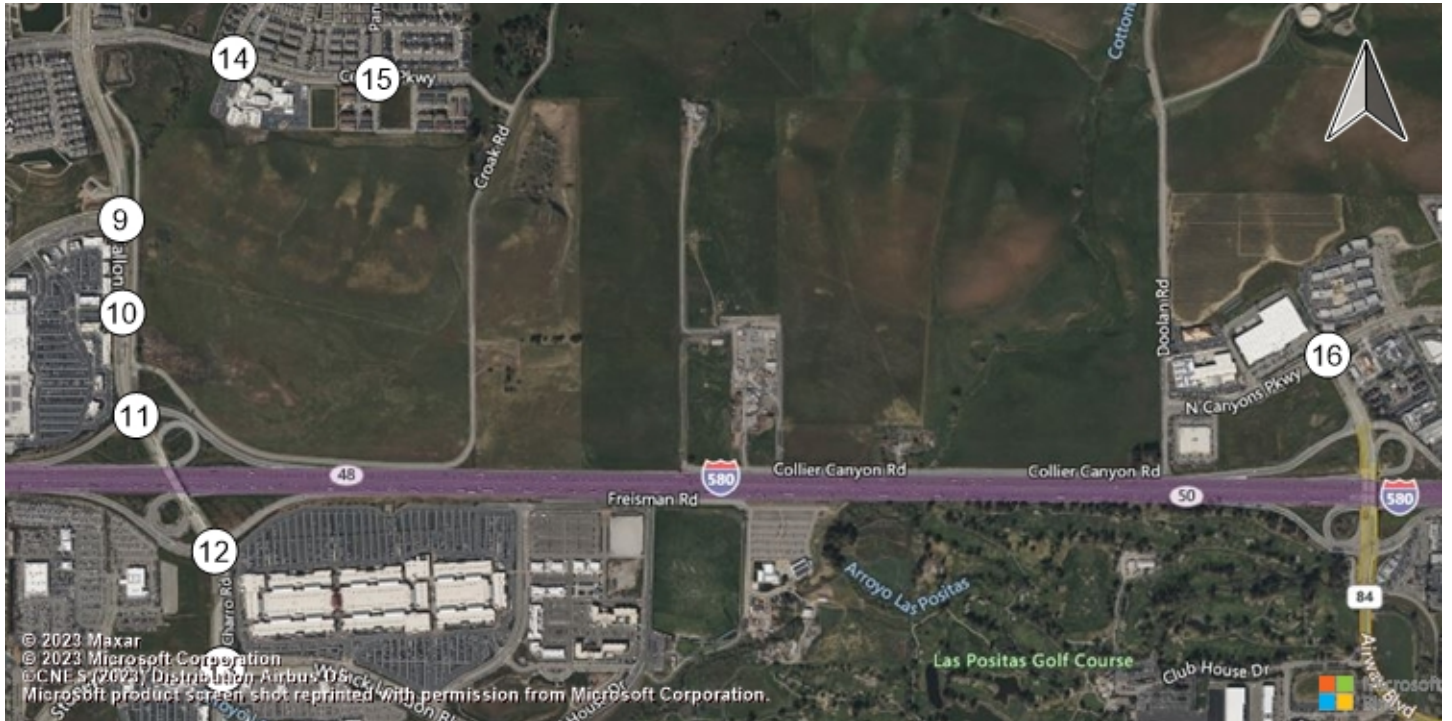

Fallon Road & Dublin Boulevard Fallon Road & Fallon Gateways Fallon Road & I-580 WB Ramp El Charro Road & I-580 EB Ramp

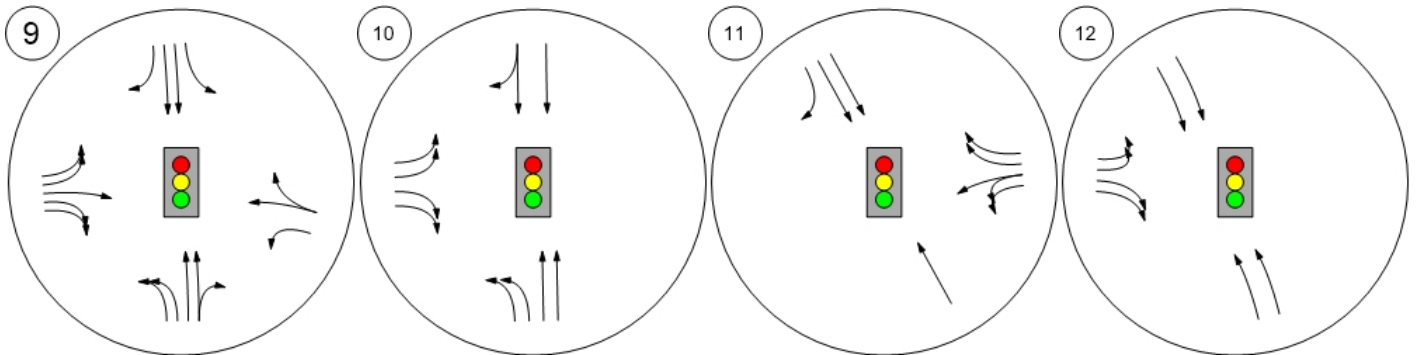

El Charro Road & Jack London Central Parkway & Sunset Vista Central Parkway & Panorama Airway Boulevard & N. Canyons

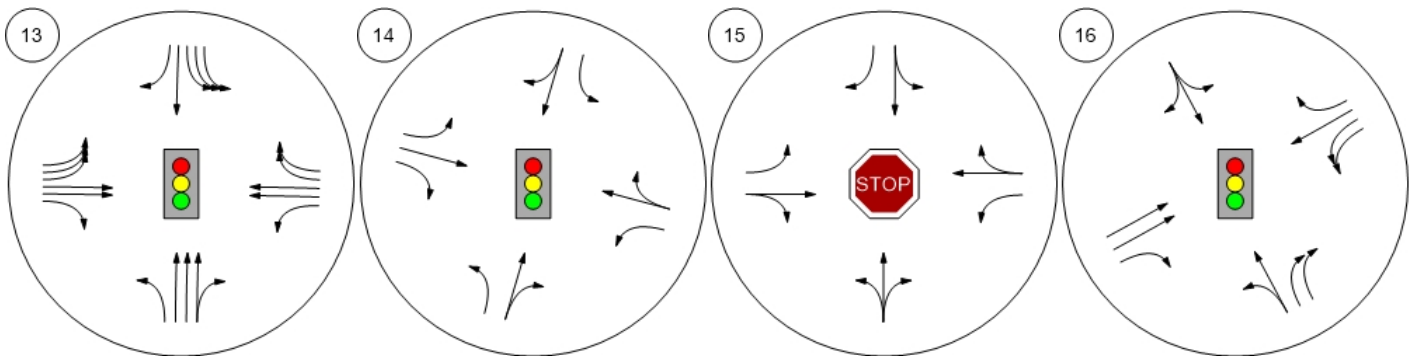

Lane Configuration and Traffic Control



Airway Boulevard & I-580 WB

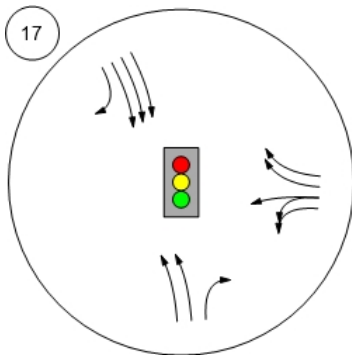



Traffic Volume - Base Volume

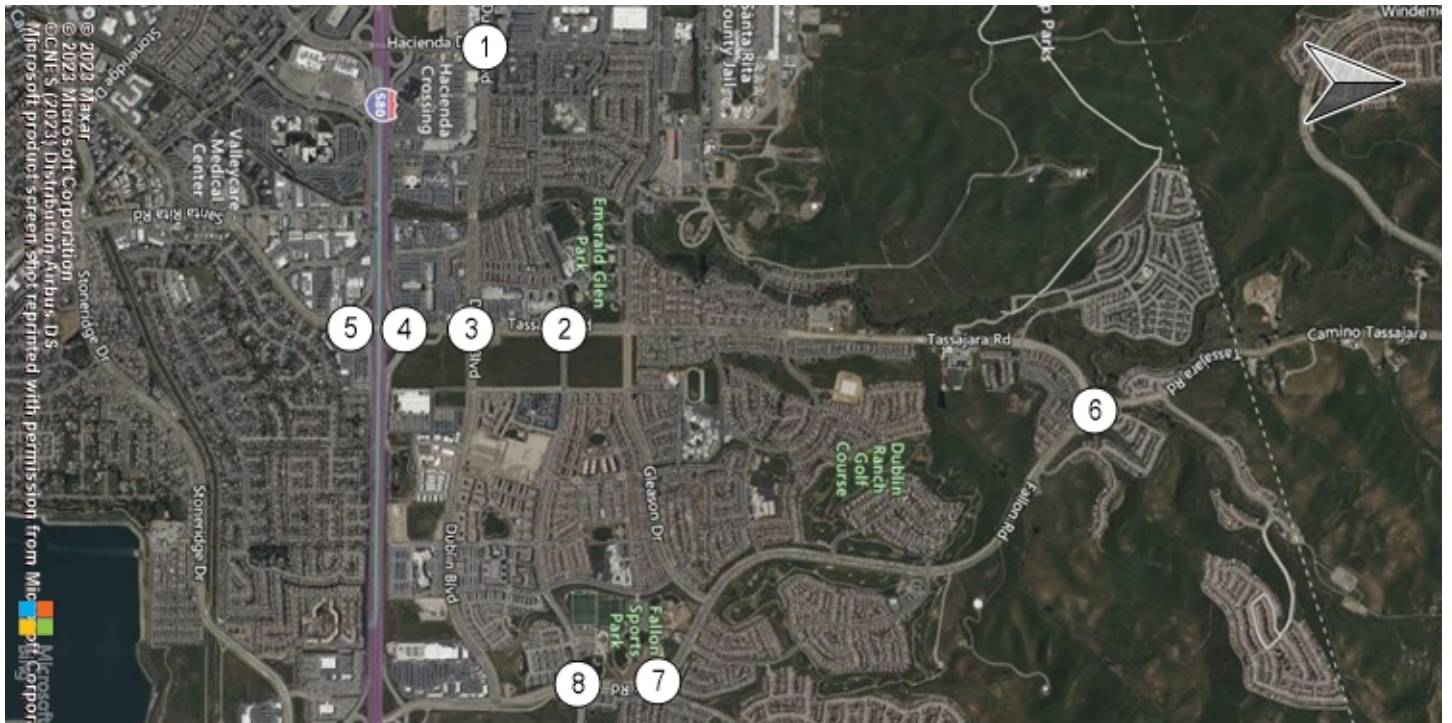

Hacienda Drive & Dublin Boul Tassajara Road & Central Pa Tassajara Road & Dublin Bou Tassajara Road & I-580 WB

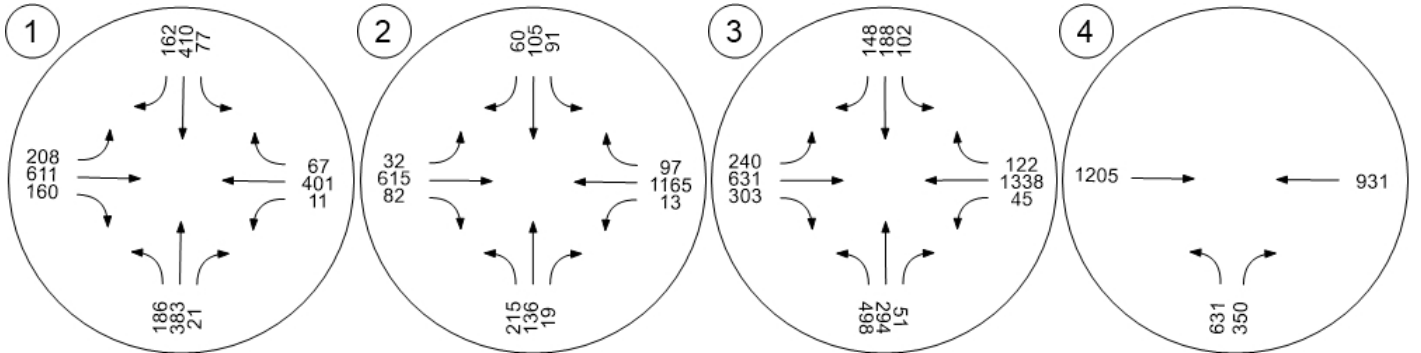

Santa Rita Rd & I-580 EB Ra Tassajara Road & Fallon Roa Fallon Road & Positano Park Fallon Road & Central Parkw

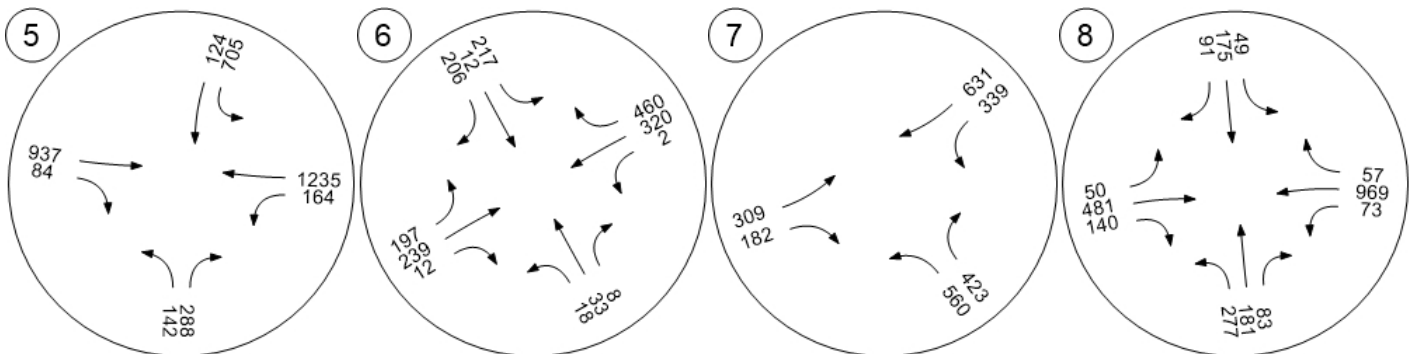

Traffic Volume - Base Volume

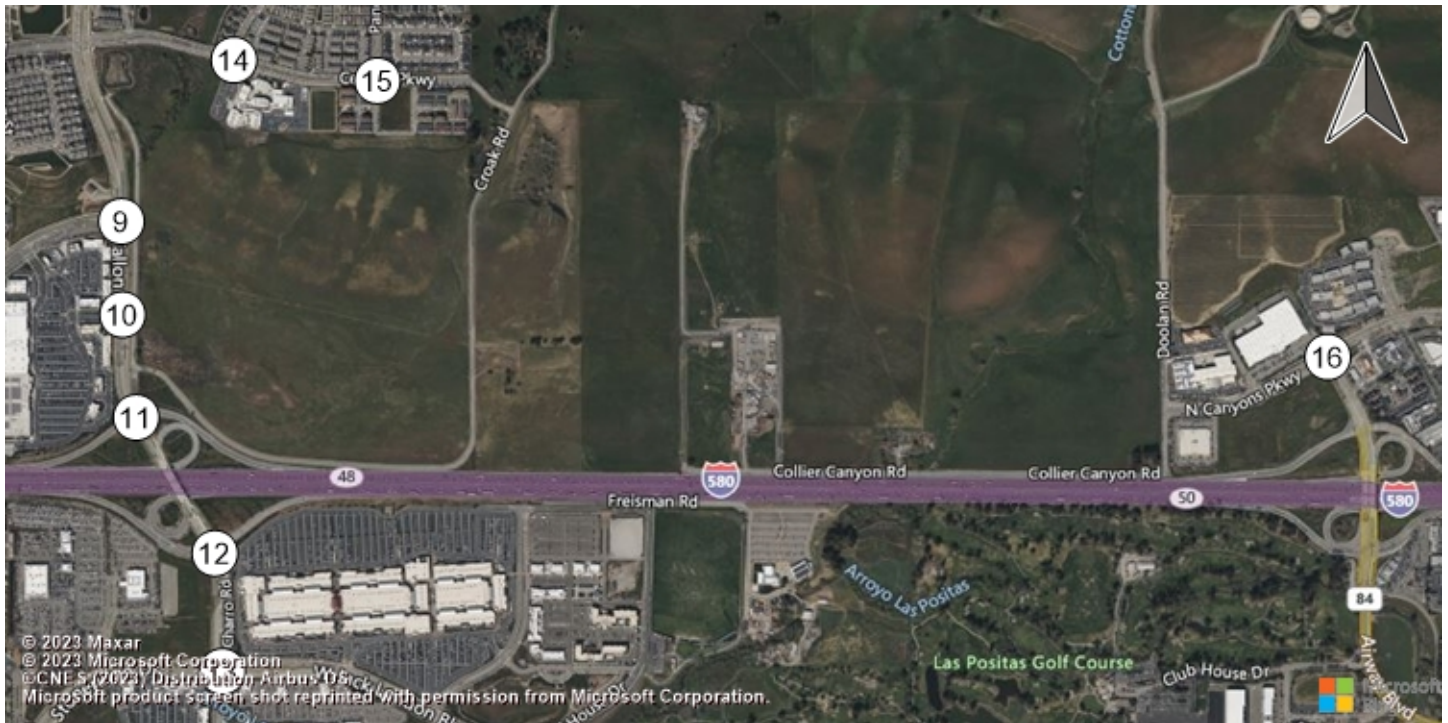

Fallon Road & Dublin Boulevard Fallon Road & Fallon Gateway Fallon Road & I-580 WB Ram El Charro Road & I-580 EB R

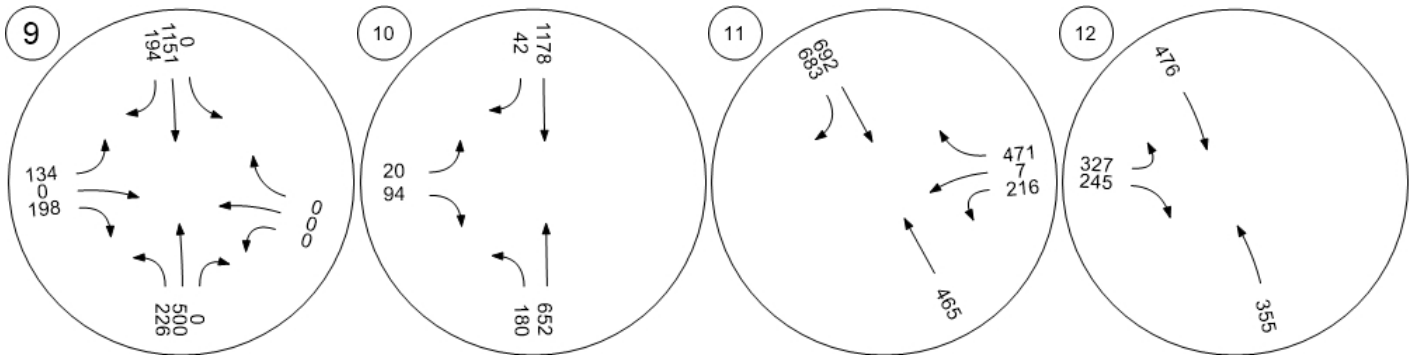

El Charro Road & Jack Lond Central Parkway & Sunset Vi Central Parkway & Panorama Airway Boulevard & N. Canyo

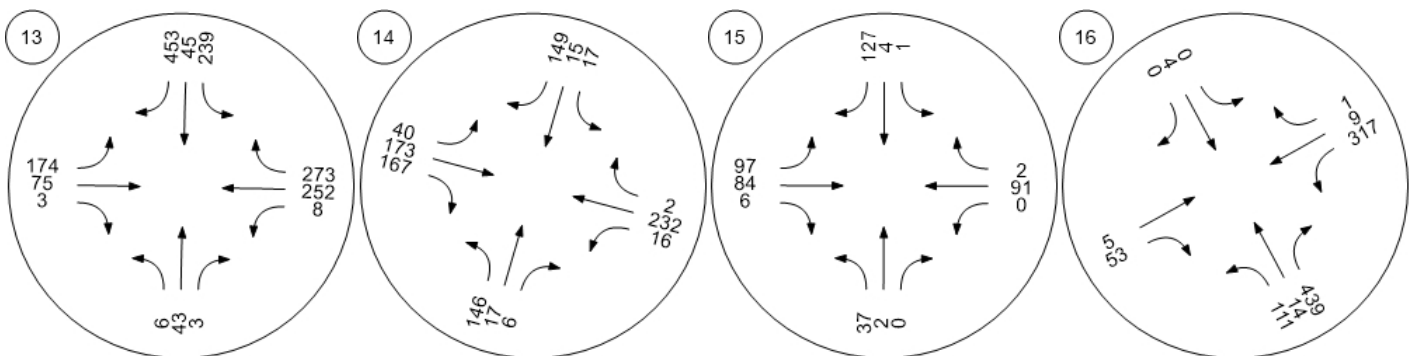



Traffic Volume - Base Volume



Airway Boulevard & I-580 WB

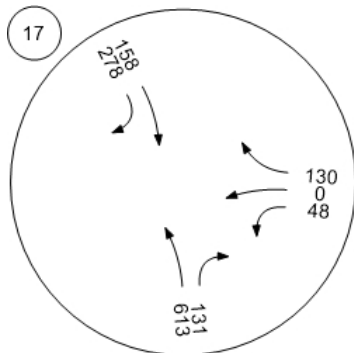

Traffic Volume - Base Volume

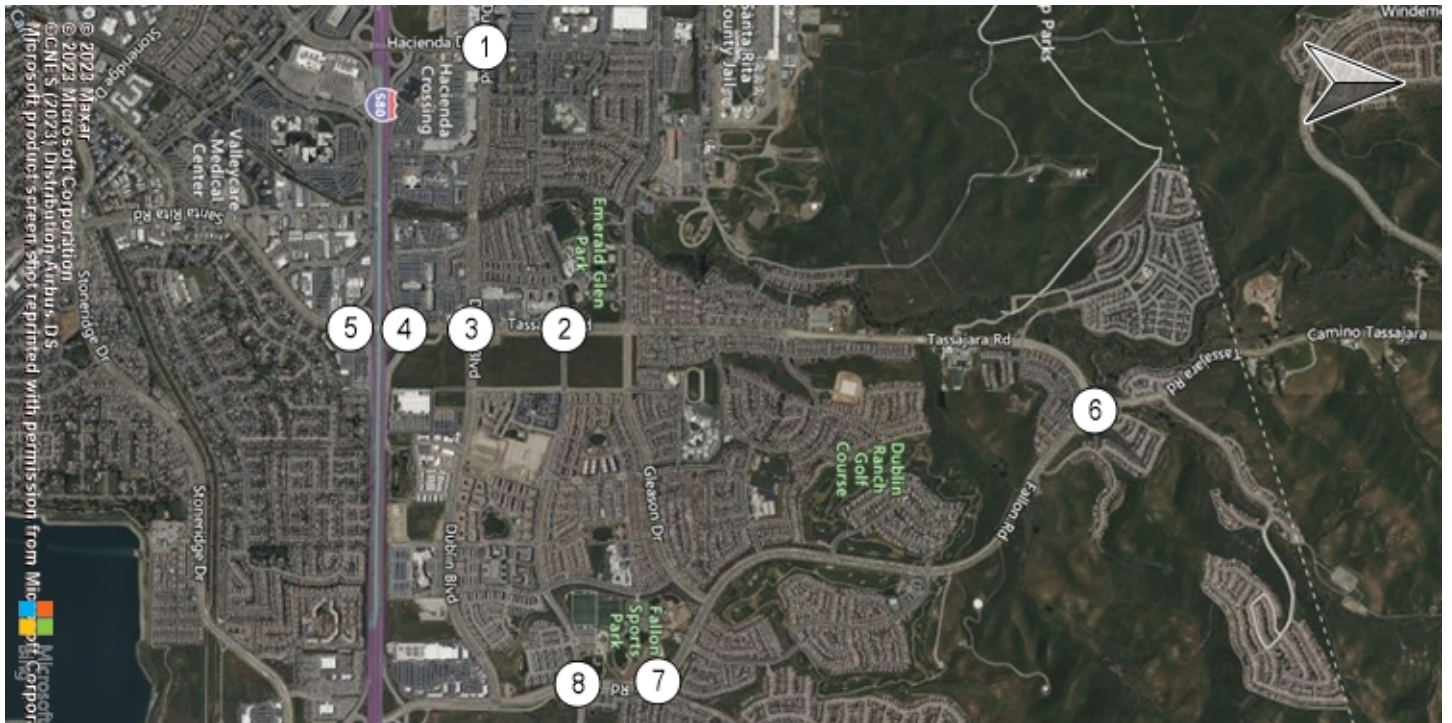

Hacienda Drive & Dublin Boul Tassajara Road & Central Pa Tassajara Road & Dublin Bou Tassajara Road & I-580 WB

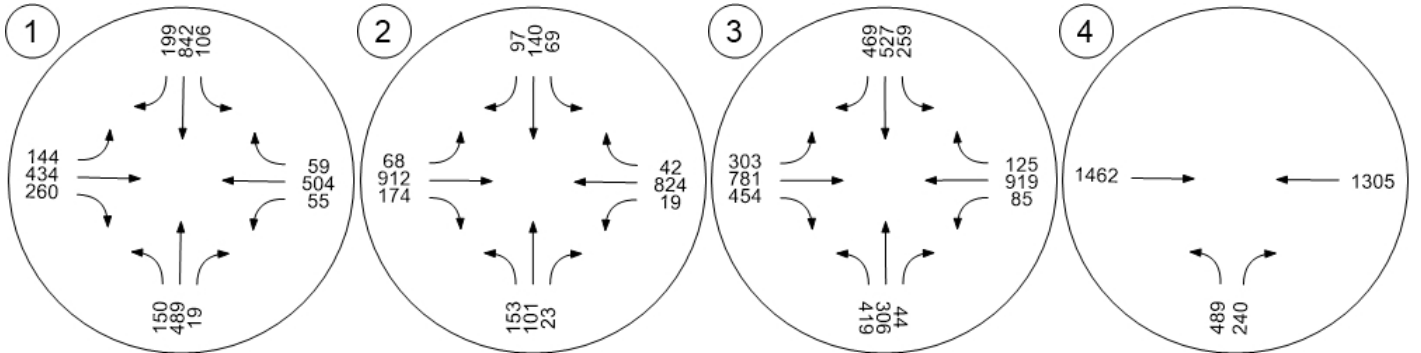

Santa Rita Rd & I-580 EB Ra Tassajara Road & Fallon Roa Fallon Road & Positano Park Fallon Road & Central Parkw

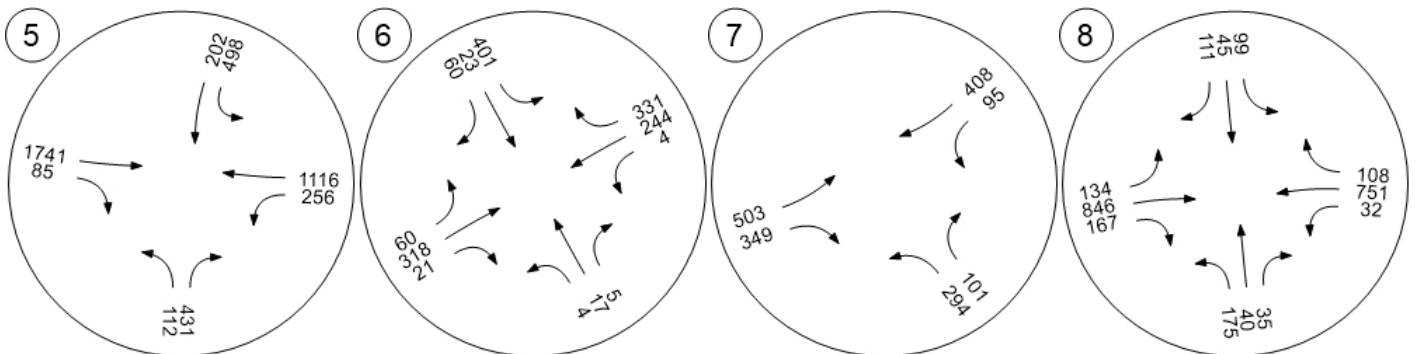



Traffic Volume - Base Volume

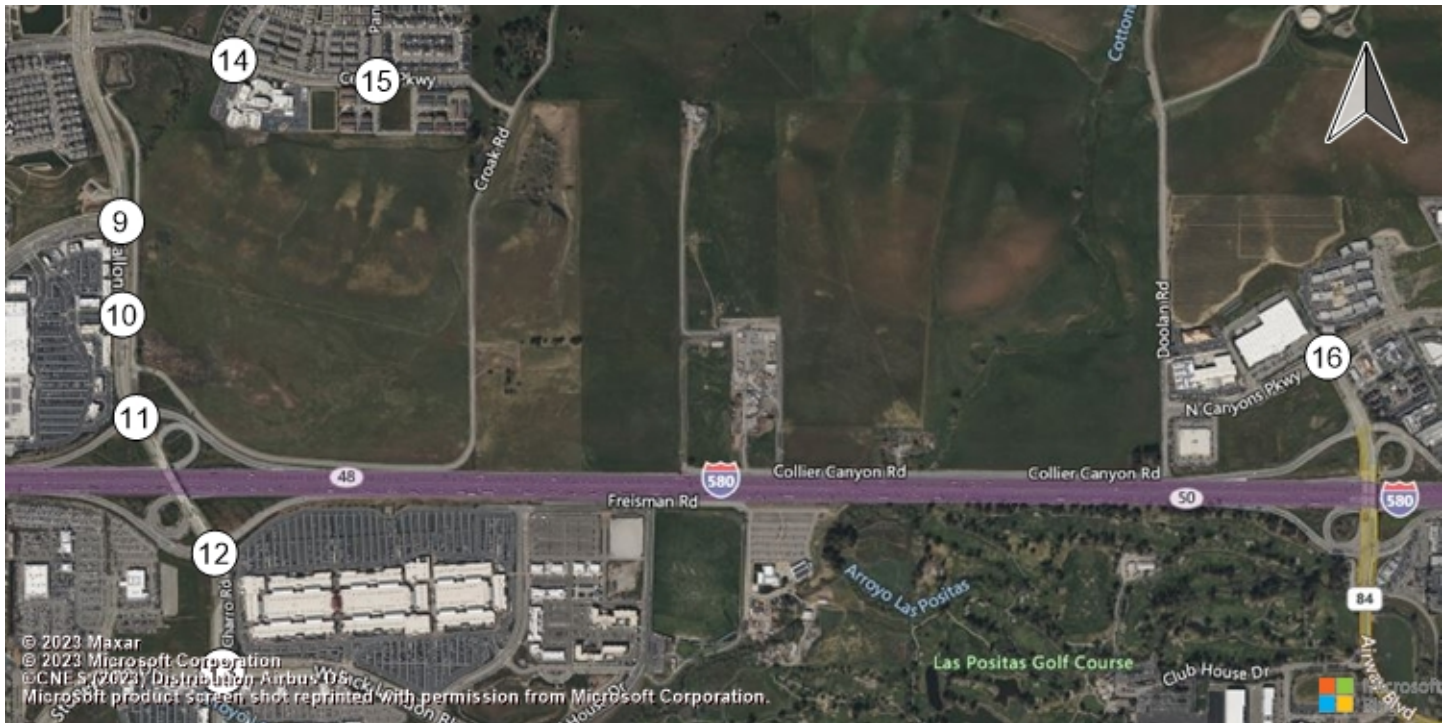

Fallon Road & Dublin Boulevard Fallon Road & Fallon Gateway Fallon Road & I-580 WB Ram El Charro Road & I-580 EB R

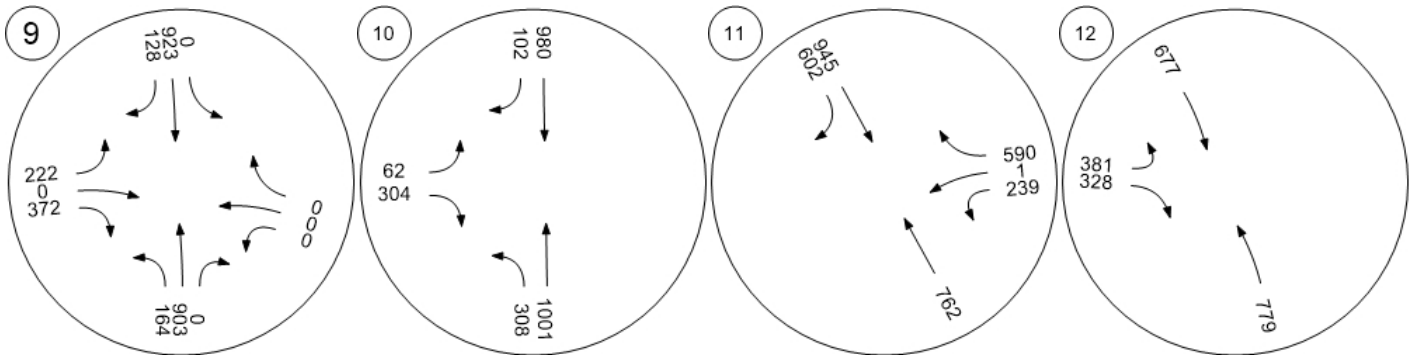

El Charro Road & Jack Lond Central Parkway & Sunset ViCentral Parkway & Panorama Airway Boulevard & N. Canyo

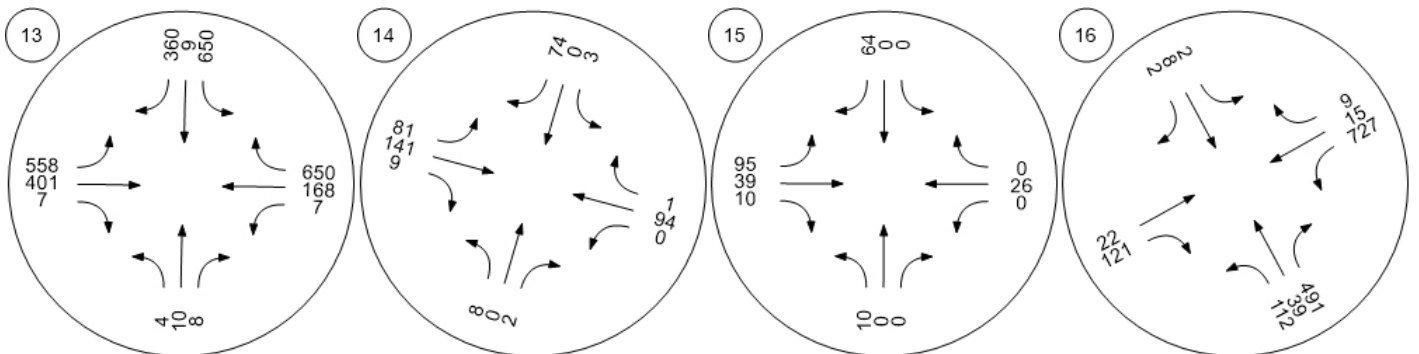

Traffic Volume - Base Volume



Airway Boulevard & I-580 WB

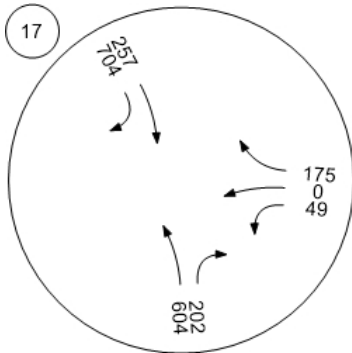



## Appendix C: Existing Operational Outputs

Vistro File: H:\...\PacVest\_20240229.vistro

Scenario 1 Existing AM

Report File: H:\...\ExistingAM\_LOS.pdf

3/1/2024

**Intersection Analysis Summary**

ID	Intersection Name	Control Type	Method	Worst Mvmt	V/C	Delay (s/veh)	LOS
1	Hacienda Drive & Dublin Boulevard	Signalized	HCM 7th Edition	SB Left	0.351	43.5	D
2	Tassajara Road & Central Parkway	Signalized	HCM 7th Edition	SB Left	0.576	28.1	C
3	Tassajara Road & Dublin Boulevard	Signalized	HCM 7th Edition	SB Left	0.481	31.8	C
4	Tassajara Road & I-580 WB Ramps	Signalized	HCM 7th Edition	WB Left	0.587	13.2	B
5	Santa Rita Rd & I-580 EB Ramps/Pimlico Dr	Signalized	HCM 7th Edition	SB Left	0.733	31.4	C
6	Tassajara Road & Fallon Road	Signalized	HCM 7th Edition	SB Left	0.642	21.9	C
7	Fallon Road & Positano Parkway	Signalized	HCM 7th Edition	SB Left	0.782	22.1	C
8	Fallon Road & Central Parkway	Signalized	HCM 7th Edition	SB Left	0.567	31.9	C
9	Fallon Road & Dublin Boulevard	Signalized	HCM 7th Edition	EB Left	0.534	20.1	C
10	Fallon Road & Fallon Gateway	Signalized	HCM 7th Edition	NB Left	0.526	13.3	B
11	Fallon Road & I-580 WB Ramps	Signalized	HCM 7th Edition	NB Thru	0.765	8.2	A
12	El Charro Road & I-580 EB Ramps	Signalized	HCM 7th Edition	EB Right	0.393	6.8	A
13	El Charro Road & Jack London Boulevard	Signalized	HCM 7th Edition	WB Left	0.291	10.5	B
14	Central Parkway & Sunset View Drive	Signalized	HCM 7th Edition	EB Left	0.756	31.0	C
15	Central Parkway & Panorama Drive/Pino Grande Road	All-way stop	HCM 7th Edition	EB Left	0.359	11.0	B
16	Airway Boulevard & N. Canyons Parkway	Signalized	HCM 7th Edition	SB Thru	0.271	13.7	B
17	Airway Boulevard & I-580 WB Ramps	Signalized	HCM 7th Edition	WB Left	0.223	9.8	A



V/C, Delay, LOS: For two-way stop, these values are taken from the movement with the worst (highest) delay value. For all other control types, they are taken for the whole intersection.

**Intersection Level Of Service Report**  
**Intersection 1: Hacienda Drive & Dublin Boulevard**

Control Type:	Signalized	Delay (sec / veh):	43.5
Analysis Method:	HCM 7th Edition	Level Of Service:	D
Analysis Period:	15 minutes	Volume to Capacity (v/c):	0.351

**Intersection Setup**

Name	Hacienda Drive			Hacienda Drive			Dublin Boulevard			Dublin Boulevard		
Approach	Northbound			Southbound			Eastbound			Westbound		
Lane Configuration	[Diagram]			[Diagram]			[Diagram]			[Diagram]		
Turning Movement	Left	Thru	Right	Left	Thru	Right	Left	Thru	Right	Left	Thru	Right
Lane Width [ft]	12.00	12.00	12.00	12.00	12.00	12.00	12.00	12.00	12.00	12.00	12.00	12.00
No. of Lanes in Entry Pocket	2	0	2	2	0	1	2	0	2	2	0	0
Entry Pocket Length [ft]	250.00	100.00	380.00	300.00	100.00	220.00	300.00	100.00	250.00	275.00	100.00	100.00
No. of Lanes in Exit Pocket	0	0	0	0	0	0	0	0	0	0	0	1
Exit Pocket Length [ft]	0.00	0.00	0.00	0.00	0.00	0.00	0.00	0.00	0.00	0.00	0.00	1000.00
Speed [mph]	35.00			35.00			40.00			40.00		
Grade [%]	0.00			0.00			0.00			0.00		
Curb Present	Yes			Yes			Yes			Yes		
Crosswalk	Yes			Yes			Yes			Yes		





**Volumes**

Name	Hacienda Drive			Hacienda Drive			Dublin Boulevard			Dublin Boulevard		
Base Volume Input [veh/h]	208	611	160	11	401	67	77	410	162	186	383	21
Base Volume Adjustment Factor	1.0000	1.0000	1.0000	1.0000	1.0000	1.0000	1.0000	1.0000	1.0000	1.0000	1.0000	1.0000
Heavy Vehicles Percentage [%]	3.40	1.10	1.90	0.00	1.50	4.50	5.20	1.70	8.60	0.50	2.30	4.80
Proportion of CAVs [%]	0.00											
Growth Factor	1.0000	1.0000	1.0000	1.0000	1.0000	1.0000	1.0000	1.0000	1.0000	1.0000	1.0000	1.0000
In-Process Volume [veh/h]	0	0	0	0	0	0	0	0	0	0	0	0
Site-Generated Trips [veh/h]	0	0	0	0	0	0	0	0	0	0	0	0
Diverted Trips [veh/h]	0	0	0	0	0	0	0	0	0	0	0	0
Pass-by Trips [veh/h]	0	0	0	0	0	0	0	0	0	0	0	0
Existing Site Adjustment Volume [veh/h]	0	0	0	0	0	0	0	0	0	0	0	0
Other Volume [veh/h]	0	0	0	0	0	0	0	0	0	0	0	0
Right Turn on Red Volume [veh/h]	0	0	0	0	0	0	0	0	0	0	0	0
Total Hourly Volume [veh/h]	208	611	160	11	401	67	77	410	162	186	383	21
Peak Hour Factor	0.9500	0.9500	0.9500	0.9500	0.9500	0.9500	0.9500	0.9500	0.9500	0.9500	0.9500	0.9500
Other Adjustment Factor	1.0000	1.0000	1.0000	1.0000	1.0000	1.0000	1.0000	1.0000	1.0000	1.0000	1.0000	1.0000
Total 15-Minute Volume [veh/h]	55	161	42	3	106	18	20	108	43	49	101	6
Total Analysis Volume [veh/h]	219	643	168	12	422	71	81	432	171	196	403	22
Presence of On-Street Parking	No		No	No		No	No		No	No		No
On-Street Parking Maneuver Rate [/h]	0	0	0	0	0	0	0	0	0	0	0	0
Local Bus Stopping Rate [/h]	0	0	0	0	0	0	0	0	0	0	0	0
v_do, Outbound Pedestrian Volume crossing	1			3			0			2		
v_di, Inbound Pedestrian Volume crossing m	0			2			1			3		
v_co, Outbound Pedestrian Volume crossing	0			2			3			1		
v_ci, Inbound Pedestrian Volume crossing mi	1			3			2			0		
v_ab, Corner Pedestrian Volume [ped/h]	0			0			0			0		
Bicycle Volume [bicycles/h]	0			0			0			1		



**Intersection Settings**

Located in CBD	No
Signal Coordination Group	-
Cycle Length [s]	150
Active Pattern	Pattern 1
Coordination Type	Time of Day Pattern Coordinated
Actuation Type	Fully actuated
Offset [s]	57.0
Offset Reference	Lead Green - Beginning of First Green
Permissive Mode	SingleBand
Lost time [s]	12.00

**Phasing & Timing (Basic)**

Control Type	Protecte	Permiss	Permiss	Protecte	Permiss	Permiss	Protecte	Permiss	Permiss	Protecte	Permiss	Permiss
Signal Group	3	8	0	7	4	0	5	2	0	1	6	0
Auxiliary Signal Groups												
Maximum Green [s]	20	50	0	20	50	0	20	60	0	20	60	0
Amber [s]	3.5	4.5	0.0	3.5	4.1	0.0	3.5	4.5	0.0	3.5	4.5	0.0
All red [s]	1.5	1.5	0.0	1.0	1.5	0.0	1.0	1.5	0.0	1.0	1.5	0.0
Walk [s]	0	4	0	0	4	0	0	4	0	0	4	0
Pedestrian Clearance [s]	0	32	0	0	40	0	0	43	0	0	35	0
Delayed Vehicle Green [s]	0.0	0.0	0.0	0.0	0.0	0.0	0.0	0.0	0.0	0.0	0.0	0.0
Rest In Walk		No			No			No			No	
I1, Start-Up Lost Time [s]	2.0	2.0	0.0	2.0	2.0	0.0	2.0	2.0	0.0	2.0	2.0	0.0
I2, Clearance Lost Time [s]	2.0	2.0	0.0	2.0	2.0	0.0	2.0	2.0	0.0	2.0	2.0	0.0
Detector Location [ft]	0.0	0.0	0.0	0.0	0.0	0.0	0.0	0.0	0.0	0.0	0.0	0.0
Detector Length [ft]	20.0	20.0	0.0	20.0	20.0	0.0	20.0	20.0	0.0	20.0	20.0	0.0
I, Upstream Filtering Factor	1.00	1.00	1.00	1.00	1.00	1.00	1.00	1.00	1.00	1.00	1.00	1.00

**Phasing & Timing: Pattern 1**

Split [s]	18	55	0	14	51	0	15	61	0	20	66	0
Lead / Lag	Lead	-	-	Lead	-	-	Lead	-	-	Lead	-	-
Minimum Green [s]	4	10	0	4	10	0	4	10	0	8	10	0
Vehicle Extension [s]	3.0	3.5	0.0	3.0	3.5	0.0	3.0	3.5	0.0	3.0	3.5	0.0
Minimum Recall	No	No		No	No		No	Yes		No	Yes	
Maximum Recall	No	No		No	No		No	No		No	No	
Pedestrian Recall	No	No		No	No		No	No		No	No	

**Exclusive Pedestrian Phase**

Pedestrian Signal Group	0
Pedestrian Walk [s]	0
Pedestrian Clearance [s]	0



**Lane Group Calculations**

Lane Group	L	C	R	L	C	R	L	C	R	L	C	C
C, Cycle Length [s]	150	150	150	150	150	150	150	150	150	150	150	150
L, Total Lost Time per Cycle [s]	4.00	4.00	4.00	4.00	4.00	4.00	4.00	4.00	4.00	4.00	4.00	4.00
l1_p, Permitted Start-Up Lost Time [s]	0.00	0.00	0.00	0.00	0.00	0.00	0.00	0.00	0.00	0.00	0.00	0.00
l2, Clearance Lost Time [s]	2.00	2.00	2.00	2.00	2.00	2.00	2.00	2.00	2.00	2.00	2.00	2.00
g_i, Effective Green Time [s]	10	33	33	2	26	26	6	88	88	11	93	93
g / C, Green / Cycle	0.06	0.22	0.22	0.01	0.17	0.17	0.04	0.58	0.58	0.07	0.62	0.62
(v / s)_i Volume / Saturation Flow Rate	0.04	0.18	0.06	0.00	0.08	0.05	0.02	0.08	0.06	0.06	0.08	0.08
s, saturation flow rate [veh/h]	5130	3586	2812	3514	5114	1544	3370	5106	2663	3500	3552	1812
c, Capacity [veh/h]	329	795	624	50	880	266	134	2980	1554	258	2193	1119
d1, Uniform Delay [s]	68.66	55.37	48.33	73.16	56.07	53.90	70.88	14.22	13.91	68.21	11.93	11.94
k, delay calibration	0.11	0.13	0.13	0.11	0.13	0.13	0.11	0.50	0.50	0.11	0.50	0.50
l, Upstream Filtering Factor	1.00	1.00	1.00	1.00	1.00	1.00	1.00	1.00	1.00	1.00	1.00	1.00
d2, Incremental Delay [s]	2.32	2.42	0.28	2.40	0.49	0.64	4.28	0.10	0.14	4.58	0.12	0.24
d3, Initial Queue Delay [s]	0.00	0.00	0.00	0.00	0.00	0.00	0.00	0.00	0.00	0.00	0.00	0.00
Rp, platoon ratio	1.00	1.00	1.00	1.00	1.00	1.00	1.00	1.00	1.00	1.00	1.00	1.00
PF, progression factor	1.00	1.00	1.00	1.00	1.00	1.00	1.00	1.00	1.00	1.00	1.00	1.00

**Lane Group Results**

X, volume / capacity	0.67	0.81	0.27	0.24	0.48	0.27	0.60	0.14	0.11	0.76	0.13	0.13
d, Delay for Lane Group [s/veh]	70.98	57.79	48.61	75.56	56.56	54.55	75.16	14.32	14.05	72.79	12.05	12.18
Lane Group LOS	E	E	D	E	E	D	E	B	B	E	B	B
Critical Lane Group	No	Yes	No	Yes	No	No	No	Yes	No	Yes	No	No
50th-Percentile Queue Length [veh/ln]	2.81	11.76	2.64	0.25	4.86	2.38	1.60	2.23	1.31	3.83	1.95	2.05
50th-Percentile Queue Length [ft/ln]	70.21	293.94	66.10	6.14	121.39	59.60	40.06	55.75	32.74	95.65	48.80	51.31
95th-Percentile Queue Length [veh/ln]	5.05	17.38	4.76	0.44	8.47	4.29	2.88	4.01	2.36	6.89	3.51	3.69
95th-Percentile Queue Length [ft/ln]	126.37	434.52	118.99	11.05	211.74	107.29	72.10	100.34	58.93	172.17	87.84	92.36



**Movement, Approach, & Intersection Results**

d_M, Delay for Movement [s/veh]	70.98	57.79	48.61	75.56	56.56	54.55	75.16	14.32	14.05	72.79	12.09	12.18
Movement LOS	E	E	D	E	E	D	E	B	B	E	B	B
d_A, Approach Delay [s/veh]	59.10			56.73			21.46			31.25		
Approach LOS	E			E			C			C		
d_I, Intersection Delay [s/veh]	43.52											
Intersection LOS	D											
Intersection V/C	0.351											

**Emissions**

Vehicle Miles Traveled [mph]	22.22	65.25	17.05	1.40	49.12	8.26	9.26	49.38	19.55	172.35	246.52	127.19
Stops [stops/h]	202.14	564.21	126.88	11.78	349.51	57.20	76.89	160.51	62.84	183.60	93.67	49.25
Fuel consumption [US gal/h]	5.53	14.29	3.27	0.33	9.36	1.53	2.33	4.60	1.81	10.88	10.44	5.40
CO [g/h]	386.55	999.01	228.27	22.81	654.11	107.17	162.56	321.83	126.26	760.50	729.63	377.34
NOx [g/h]	75.21	194.37	44.41	4.44	127.27	20.85	31.63	62.62	24.57	147.97	141.96	73.42
VOC [g/h]	89.59	231.53	52.90	5.29	151.60	24.84	37.68	74.59	29.26	176.25	169.10	87.45

**Other Modes**

g_Walk,mi, Effective Walk Time [s]	8.0			8.0			8.0			8.0		
M_corner, Corner Circulation Area [ft <sup>2</sup> /ped]	0.00			0.00			0.00			0.00		
M_CW, Crosswalk Circulation Area [ft <sup>2</sup> /ped]	3538.91			931.81			870.62			3179.53		
d_p, Pedestrian Delay [s]	67.23			67.23			67.23			67.23		
I_p,int, Pedestrian LOS Score for Intersectio	3.199			2.929			3.172			2.952		
Crosswalk LOS	C			C			C			C		
s_b, Saturation Flow Rate of the bicycle lane	2000			2000			2000			2000		
c_b, Capacity of the bicycle lane [bicycles/h]	653			605			733			800		
d_b, Bicycle Delay [s]	34.02			36.49			30.10			27.03		
I_b,int, Bicycle LOS Score for Intersection	2.409			1.837			1.936			1.901		
Bicycle LOS	B			A			A			A		

**Sequence**

Ring 1	1	2	3	4	-	-	-	-	-	-	-	-	-	-	-
Ring 2	5	6	7	8	-	-	-	-	-	-	-	-	-	-	-
Ring 3	-	-	-	-	-	-	-	-	-	-	-	-	-	-	-
Ring 4	-	-	-	-	-	-	-	-	-	-	-	-	-	-	-

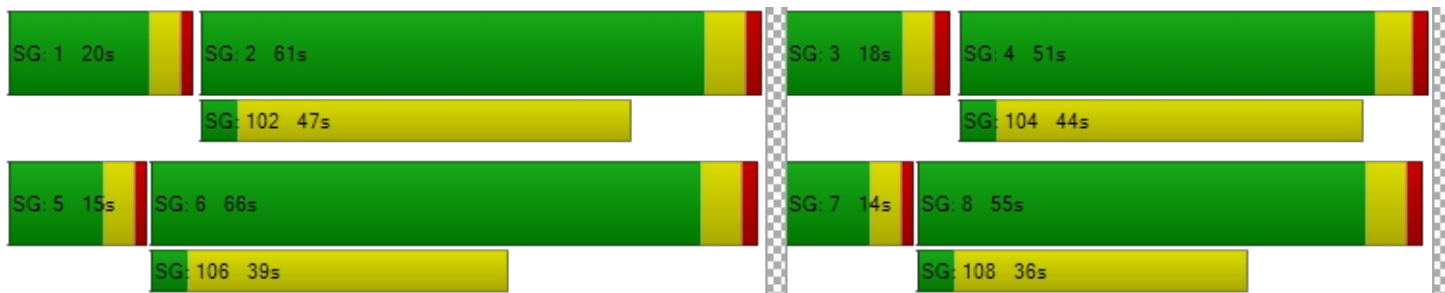

**Intersection Level Of Service Report**  
**Intersection 2: Tassajara Road & Central Parkway**

Control Type:	Signalized	Delay (sec / veh):	28.1
Analysis Method:	HCM 7th Edition	Level Of Service:	C
Analysis Period:	15 minutes	Volume to Capacity (v/c):	0.576

**Intersection Setup**

Name	Tassajara Road			Tassajara Road			Central Parkway			Central Parkway		
Approach	Northbound			Southbound			Eastbound			Westbound		
Lane Configuration	⇐   ⇐			⇐   ⇐			⇐  ⇐			⇐  ⇐		
Turning Movement	Left	Thru	Right	Left	Thru	Right	Left	Thru	Right	Left	Thru	Right
Lane Width [ft]	12.00	12.00	12.00	12.00	12.00	12.00	12.00	12.00	12.00	12.00	12.00	12.00
No. of Lanes in Entry Pocket	1	0	1	1	0	1	1	0	1	2	0	0
Entry Pocket Length [ft]	325.00	100.00	325.00	300.00	100.00	215.00	225.00	100.00	225.00	300.00	100.00	100.00
No. of Lanes in Exit Pocket	0	0	0	0	0	0	0	0	0	0	0	0
Exit Pocket Length [ft]	0.00	0.00	0.00	0.00	0.00	0.00	0.00	0.00	0.00	0.00	0.00	0.00
Speed [mph]	40.00			40.00			35.00			35.00		
Grade [%]	0.00			0.00			0.00			0.00		
Curb Present	Yes			Yes			Yes			Yes		
Crosswalk	Yes			Yes			Yes			Yes		



**Volumes**

Name	Tassajara Road			Tassajara Road			Central Parkway			Central Parkway		
Base Volume Input [veh/h]	32	615	82	13	1165	97	91	105	60	215	136	19
Base Volume Adjustment Factor	1.0000	1.0000	1.0000	1.0000	1.0000	1.0000	1.0000	1.0000	1.0000	1.0000	1.0000	1.0000
Heavy Vehicles Percentage [%]	0.00	2.00	8.50	0.00	0.70	2.10	1.10	0.00	1.70	0.90	0.00	0.00
Proportion of CAVs [%]	0.00											
Growth Factor	1.0000	1.0000	1.0000	1.0000	1.0000	1.0000	1.0000	1.0000	1.0000	1.0000	1.0000	1.0000
In-Process Volume [veh/h]	0	0	0	0	0	0	0	0	0	0	0	0
Site-Generated Trips [veh/h]	0	0	0	0	0	0	0	0	0	0	0	0
Diverted Trips [veh/h]	0	0	0	0	0	0	0	0	0	0	0	0
Pass-by Trips [veh/h]	0	0	0	0	0	0	0	0	0	0	0	0
Existing Site Adjustment Volume [veh/h]	0	0	0	0	0	0	0	0	0	0	0	0
Other Volume [veh/h]	0	0	0	0	0	0	0	0	0	0	0	0
Right Turn on Red Volume [veh/h]	0	0	0	0	0	0	0	0	0	0	0	0
Total Hourly Volume [veh/h]	32	615	82	13	1165	97	91	105	60	215	136	19
Peak Hour Factor	0.9100	0.9100	0.9100	0.9100	0.9100	0.9100	0.9100	0.9100	0.9100	0.9100	0.9100	0.9100
Other Adjustment Factor	1.0000	1.0000	1.0000	1.0000	1.0000	1.0000	1.0000	1.0000	1.0000	1.0000	1.0000	1.0000
Total 15-Minute Volume [veh/h]	9	169	23	4	320	27	25	29	16	59	37	5
Total Analysis Volume [veh/h]	35	676	90	14	1280	107	100	115	66	236	149	21
Presence of On-Street Parking	No		No	No		No	No		No	No		No
On-Street Parking Maneuver Rate [/h]	0	0	0	0	0	0	0	0	0	0	0	0
Local Bus Stopping Rate [/h]	0	0	0	0	0	0	0	0	0	0	0	0
v_do, Outbound Pedestrian Volume crossing	2			2			1			2		
v_di, Inbound Pedestrian Volume crossing m	1			2			2			2		
v_co, Outbound Pedestrian Volume crossing	1			6			7			2		
v_ci, Inbound Pedestrian Volume crossing mi	2			7			6			1		
v_ab, Corner Pedestrian Volume [ped/h]	0			0			0			0		
Bicycle Volume [bicycles/h]	0			0			0			12		



**Intersection Settings**

Located in CBD	No
Signal Coordination Group	-
Cycle Length [s]	130
Active Pattern	Pattern 1
Coordination Type	Time of Day Pattern Coordinated
Actuation Type	Fully actuated
Offset [s]	20.0
Offset Reference	Lead Green - Beginning of First Green
Permissive Mode	SingleBand
Lost time [s]	12.00

**Phasing & Timing (Basic)**

Control Type	Protecte	Permiss	Permiss	Protecte	Permiss	Permiss	Protecte	Permiss	Permiss	Protecte	Permiss	Permiss
Signal Group	3	8	0	7	4	0	5	2	0	1	6	0
Auxiliary Signal Groups												
Maximum Green [s]	20	40	0	20	40	0	20	20	0	20	20	0
Amber [s]	3.5	4.3	0.0	3.5	4.3	0.0	3.5	4.1	0.0	3.5	4.1	0.0
All red [s]	1.0	1.0	0.0	1.0	1.0	0.0	1.0	1.0	0.0	1.0	1.0	0.0
Walk [s]	0	4	0	0	4	0	0	4	0	0	4	0
Pedestrian Clearance [s]	0	20	0	0	24	0	0	36	0	0	30	0
Delayed Vehicle Green [s]	0.0	0.0	0.0	0.0	0.0	0.0	0.0	0.0	0.0	0.0	0.0	0.0
Rest In Walk		No			No			No			No	
I1, Start-Up Lost Time [s]	2.0	2.0	0.0	2.0	2.0	0.0	2.0	2.0	0.0	2.0	2.0	0.0
I2, Clearance Lost Time [s]	2.5	3.3	0.0	2.5	3.3	0.0	2.5	3.1	0.0	2.5	3.1	0.0
Detector Location [ft]	0.0	0.0	0.0	0.0	0.0	0.0	0.0	0.0	0.0	0.0	0.0	0.0
Detector Length [ft]	20.0	20.0	0.0	20.0	20.0	0.0	20.0	20.0	0.0	20.0	20.0	0.0
I, Upstream Filtering Factor	1.00	1.00	1.00	1.00	1.00	1.00	1.00	1.00	1.00	1.00	1.00	1.00

**Phasing & Timing: Pattern 1**

Split [s]	18	48	0	18	48	0	23	45	0	19	41	0
Lead / Lag	Lead	-	-	Lead	-	-	Lead	-	-	Lead	-	-
Minimum Green [s]	13	12	0	13	12	0	13	13	0	14	13	0
Vehicle Extension [s]	2.5	4.0	0.0	2.5	4.0	0.0	2.5	2.5	0.0	2.5	2.5	0.0
Minimum Recall	No	Yes		No	Yes		No	No		No	No	
Maximum Recall	No	No		No	No		No	No		No	No	
Pedestrian Recall	No	No		No	No		No	No		No	No	

**Exclusive Pedestrian Phase**

Pedestrian Signal Group	0
Pedestrian Walk [s]	0
Pedestrian Clearance [s]	0



**Lane Group Calculations**

Lane Group	L	C	R	L	C	R	L	C	R	L	C
C, Cycle Length [s]	130	130	130	130	130	130	130	130	130	130	130
L, Total Lost Time per Cycle [s]	4.50	5.30	5.30	4.50	5.30	5.30	4.50	5.10	5.10	4.50	5.10
l1_p, Permitted Start-Up Lost Time [s]	0.00	0.00	0.00	0.00	0.00	0.00	0.00	0.00	0.00	0.00	0.00
l2, Clearance Lost Time [s]	2.50	3.30	3.30	2.50	3.30	3.30	2.50	3.10	3.10	2.50	3.10
g_i, Effective Green Time [s]	9	77	77	5	73	73	13	14	14	14	16
g / C, Green / Cycle	0.07	0.59	0.59	0.04	0.56	0.56	0.10	0.11	0.11	0.11	0.12
(v / s)_i Volume / Saturation Flow Rate	0.02	0.19	0.06	0.01	0.36	0.07	0.06	0.06	0.04	0.07	0.09
s, saturation flow rate [veh/h]	1810	3560	1503	1810	3598	1570	1794	1900	1580	3489	1848
c, Capacity [veh/h]	130	2106	889	73	2013	878	175	211	176	376	225
d1, Uniform Delay [s]	57.06	13.38	11.53	60.34	19.56	13.51	56.05	54.64	53.55	55.47	55.22
k, delay calibration	0.08	0.50	0.50	0.08	0.50	0.50	0.08	0.08	0.08	0.08	0.08
l, Upstream Filtering Factor	1.00	1.00	1.00	1.00	1.00	1.00	1.00	1.00	1.00	1.00	1.00
d2, Incremental Delay [s]	0.81	0.40	0.23	0.95	1.55	0.28	2.18	1.62	0.98	1.28	3.86
d3, Initial Queue Delay [s]	0.00	0.00	0.00	0.00	0.00	0.00	0.00	0.00	0.00	0.00	0.00
Rp, platoon ratio	1.00	1.00	1.00	1.00	1.00	1.00	1.00	1.00	1.00	1.00	1.00
PF, progression factor	1.00	1.00	1.00	1.00	1.00	1.00	1.00	1.00	1.00	1.00	1.00

**Lane Group Results**

X, volume / capacity	0.27	0.32	0.10	0.19	0.64	0.12	0.57	0.54	0.38	0.63	0.76
d, Delay for Lane Group [s/veh]	57.87	13.78	11.76	61.29	21.11	13.80	58.22	56.26	54.53	56.75	59.09
Lane Group LOS	E	B	B	E	C	B	E	E	D	E	E
Critical Lane Group	Yes	No	No	No	Yes	No	Yes	No	No	No	Yes
50th-Percentile Queue Length [veh/ln]	1.11	4.87	1.15	0.46	12.90	1.51	3.23	3.64	2.04	3.75	5.60
50th-Percentile Queue Length [ft/ln]	27.66	121.79	28.67	11.53	322.49	37.73	80.69	91.07	51.09	93.75	139.93
95th-Percentile Queue Length [veh/ln]	1.99	8.49	2.06	0.83	18.79	2.72	5.81	6.56	3.68	6.75	9.48
95th-Percentile Queue Length [ft/ln]	49.78	212.29	51.61	20.75	469.74	67.91	145.24	163.92	91.96	168.76	236.94



**Movement, Approach, & Intersection Results**

d_M, Delay for Movement [s/veh]	57.87	13.78	11.76	61.29	21.11	13.80	58.22	56.26	54.53	56.75	59.09	59.09
Movement LOS	E	B	B	E	C	B	E	E	D	E	E	E
d_A, Approach Delay [s/veh]	15.48			20.95			56.55			57.73		
Approach LOS	B			C			E			E		
d_I, Intersection Delay [s/veh]	28.07											
Intersection LOS	C											
Intersection V/C	0.576											

**Emissions**

Vehicle Miles Traveled [mph]	10.09	194.95	25.95	2.66	243.49	20.35	13.16	15.13	8.69	32.00	23.05
Stops [stops/h]	30.64	269.86	31.77	12.77	714.55	41.80	89.39	100.89	56.60	207.73	155.03
Fuel consumption [US gal/h]	1.07	11.53	1.46	0.40	21.24	1.44	2.36	2.65	1.49	5.51	4.09
CO [g/h]	75.12	805.98	101.85	27.64	1484.63	100.66	164.87	185.38	104.09	384.94	285.78
NOx [g/h]	14.62	156.81	19.82	5.38	288.86	19.59	32.08	36.07	20.25	74.90	55.60
VOC [g/h]	17.41	186.79	23.60	6.41	344.08	23.33	38.21	42.96	24.12	89.21	66.23

**Other Modes**

g_Walk,mi, Effective Walk Time [s]	8.0			8.0			8.0			8.0		
M_corner, Corner Circulation Area [ft <sup>2</sup> /ped]	0.00			0.00			0.00			0.00		
M_CW, Crosswalk Circulation Area [ft <sup>2</sup> /ped]	1666.25			1344.85			271.89			1196.46		
d_p, Pedestrian Delay [s]	57.24			57.24			57.24			57.24		
I_p,int, Pedestrian LOS Score for Intersectio	3.132			2.949			2.313			2.328		
Crosswalk LOS	C			C			B			B		
s_b, Saturation Flow Rate of the bicycle lane	2000			2000			2000			2000		
c_b, Capacity of the bicycle lane [bicycles/h]	657			657			614			552		
d_b, Bicycle Delay [s]	29.30			29.30			31.21			34.25		
I_b,int, Bicycle LOS Score for Intersection	2.220			2.715			2.023			2.230		
Bicycle LOS	B			B			B			B		

**Sequence**

Ring 1	1	2	3	4	-	-	-	-	-	-	-	-	-	-	-
Ring 2	5	6	7	8	-	-	-	-	-	-	-	-	-	-	-
Ring 3	-	-	-	-	-	-	-	-	-	-	-	-	-	-	-
Ring 4	-	-	-	-	-	-	-	-	-	-	-	-	-	-	-

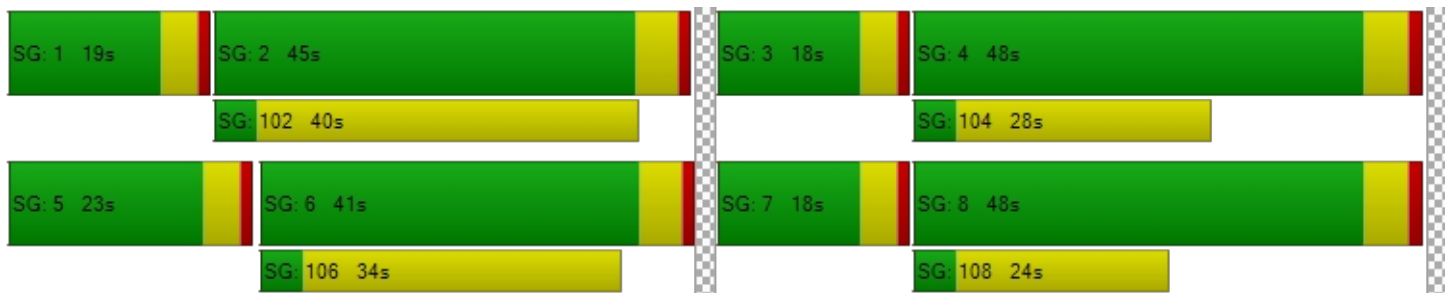

**Intersection Level Of Service Report**  
**Intersection 3: Tassajara Road & Dublin Boulevard**

Control Type:	Signalized	Delay (sec / veh):	31.8
Analysis Method:	HCM 7th Edition	Level Of Service:	C
Analysis Period:	15 minutes	Volume to Capacity (v/c):	0.481

**Intersection Setup**

Name	Tassajara Road			Tassajara Road			Dublin Boulevard			Dublin Boulevard		
Approach	Northbound			Southbound			Eastbound			Westbound		
Lane Configuration	[Diagram]			[Diagram]			[Diagram]			[Diagram]		
Turning Movement	Left	Thru	Right	Left	Thru	Right	Left	Thru	Right	Left	Thru	Right
Lane Width [ft]	12.00	12.00	12.00	12.00	12.00	12.00	12.00	12.00	12.00	12.00	12.00	12.00
No. of Lanes in Entry Pocket	3	0	1	2	0	2	2	0	2	3	0	0
Entry Pocket Length [ft]	380.00	100.00	250.00	295.00	100.00	290.00	265.00	100.00	330.00	395.00	100.00	100.00
No. of Lanes in Exit Pocket	0	0	1	0	0	0	0	0	0	0	0	0
Exit Pocket Length [ft]	0.00	0.00	49.21	0.00	0.00	0.00	0.00	0.00	0.00	0.00	0.00	0.00
Speed [mph]	30.00			40.00			40.00			40.00		
Grade [%]	0.00			0.00			0.00			0.00		
Curb Present	Yes			Yes			Yes			Yes		
Crosswalk	Yes			Yes			Yes			Yes		



**Volumes**

Name	Tassajara Road			Tassajara Road			Dublin Boulevard			Dublin Boulevard		
Base Volume Input [veh/h]	240	631	303	45	1338	122	102	188	148	498	294	51
Base Volume Adjustment Factor	1.0000	1.0000	1.0000	1.0000	1.0000	1.0000	1.0000	1.0000	1.0000	1.0000	1.0000	1.0000
Heavy Vehicles Percentage [%]	3.30	2.90	1.00	0.00	0.70	3.30	2.00	3.70	4.70	1.60	2.00	0.00
Proportion of CAVs [%]	0.00											
Growth Factor	1.0000	1.0000	1.0000	1.0000	1.0000	1.0000	1.0000	1.0000	1.0000	1.0000	1.0000	1.0000
In-Process Volume [veh/h]	0	0	0	0	0	0	0	0	0	0	0	0
Site-Generated Trips [veh/h]	0	0	0	0	0	0	0	0	0	0	0	0
Diverted Trips [veh/h]	0	0	0	0	0	0	0	0	0	0	0	0
Pass-by Trips [veh/h]	0	0	0	0	0	0	0	0	0	0	0	0
Existing Site Adjustment Volume [veh/h]	0	0	0	0	0	0	0	0	0	0	0	0
Other Volume [veh/h]	0	0	0	0	0	0	0	0	0	0	0	0
Right Turn on Red Volume [veh/h]	0	0	0	0	0	0	0	0	0	0	0	0
Total Hourly Volume [veh/h]	240	631	303	45	1338	122	102	188	148	498	294	51
Peak Hour Factor	0.9200	0.9200	0.9200	0.9200	0.9200	0.9200	0.9200	0.9200	0.9200	0.9200	0.9200	0.9200
Other Adjustment Factor	1.0000	1.0000	1.0000	1.0000	1.0000	1.0000	1.0000	1.0000	1.0000	1.0000	1.0000	1.0000
Total 15-Minute Volume [veh/h]	65	171	82	12	364	33	28	51	40	135	80	14
Total Analysis Volume [veh/h]	261	686	329	49	1454	133	111	204	161	541	320	55
Presence of On-Street Parking	No		No	No		No	No		No	No		No
On-Street Parking Maneuver Rate [/h]	0	0	0	0	0	0	0	0	0	0	0	0
Local Bus Stopping Rate [/h]	0	0	0	0	0	0	0	0	0	0	0	0
v_do, Outbound Pedestrian Volume crossing	1			2			2			1		
v_di, Inbound Pedestrian Volume crossing m	1			2			2			1		
v_co, Outbound Pedestrian Volume crossing	0			4			0			3		
v_ci, Inbound Pedestrian Volume crossing mi	0			3			0			4		
v_ab, Corner Pedestrian Volume [ped/h]	0			0			0			0		
Bicycle Volume [bicycles/h]	1			0			0			0		



**Intersection Settings**

Located in CBD	No
Signal Coordination Group	-
Cycle Length [s]	90
Active Pattern	Free Running (No Pattern)
Coordination Type	<i>Free Running</i>
Actuation Type	<i>Fully actuated</i>
Offset [s]	0.0
Offset Reference	Lead Green - Beginning of First Green
Permissive Mode	SingleBand
Lost time [s]	12.00

**Phasing & Timing (Basic)**

Control Type	Protecte	Permiss	Permiss	Protecte	Permiss	Permiss	Protecte	Permiss	Overlap	Protecte	Permiss	Permiss
Signal Group	3	8	0	7	4	0	5	2	2	1	6	0
Auxiliary Signal Groups									2,3			
Maximum Green [s]	20	35	0	20	35	0	20	35	35	20	35	0
Amber [s]	3.5	4.5	0.0	3.5	4.5	0.0	3.5	4.5	4.5	3.5	4.5	0.0
All red [s]	1.5	1.5	0.0	1.5	1.5	0.0	1.5	1.5	1.5	1.5	1.5	0.0
Walk [s]	0	4	0	0	4	0	0	0	0	0	4	0
Pedestrian Clearance [s]	0	29	0	0	42	0	0	0	0	0	42	0
Delayed Vehicle Green [s]	0.0	0.0	0.0	0.0	0.0	0.0	0.0	0.0	0.0	0.0	0.0	0.0
Rest In Walk		No			No			No			No	
I1, Start-Up Lost Time [s]	2.0	2.0	0.0	2.0	2.0	0.0	2.0	2.0	2.0	2.0	2.0	0.0
I2, Clearance Lost Time [s]	2.0	2.0	0.0	2.0	2.0	0.0	2.0	2.0	2.0	2.0	2.0	0.0
Detector Location [ft]	0.0	0.0	0.0	0.0	0.0	0.0	0.0	0.0	0.0	0.0	0.0	0.0
Detector Length [ft]	20.0	20.0	0.0	20.0	20.0	0.0	20.0	20.0	20.0	20.0	20.0	0.0
I, Upstream Filtering Factor	1.00	1.00	1.00	1.00	1.00	1.00	1.00	1.00	1.00	1.00	1.00	1.00

**Phasing & Timing: Free Running (No Pattern)**

Split [s]	0	0	0	0	0	0	0	0	0	0	0	0
Lead / Lag	Lead	-	-	Lead	-	-	Lead	-	-	Lead	-	-
Minimum Green [s]	16	15	0	15	15	0	16	16	16	16	15	0
Vehicle Extension [s]	2.0	4.0	0.0	2.0	4.0	0.0	2.0	3.0	3.0	2.0	3.0	0.0
Minimum Recall	No	Yes		No	Yes		No	No	No	No	No	
Maximum Recall	No	No		No	No		No	No	No	No	No	
Pedestrian Recall	No	No		No	No		No	No	No	No	No	

**Exclusive Pedestrian Phase**

Pedestrian Signal Group	0
Pedestrian Walk [s]	0
Pedestrian Clearance [s]	0



**Lane Group Calculations**

Lane Group	L	C	R	L	C	R	L	C	R	L	C	C
C, Cycle Length [s]	103	103	103	103	103	103	103	103	103	103	103	103
L, Total Lost Time per Cycle [s]	4.00	4.00	4.00	4.00	4.00	4.00	4.00	4.00	4.00	4.00	4.00	4.00
l1_p, Permitted Start-Up Lost Time [s]	0.00	0.00	0.00	0.00	0.00	0.00	0.00	0.00	0.00	0.00	0.00	0.00
l2, Clearance Lost Time [s]	2.00	2.00	2.00	2.00	2.00	2.00	2.00	2.00	0.00	2.00	2.00	2.00
g_i, Effective Green Time [s]	17	38	38	12	34	34	16	19	40	17	20	20
g / C, Green / Cycle	0.16	0.37	0.37	0.12	0.33	0.33	0.16	0.19	0.39	0.16	0.19	0.19
(v / s)_i Volume / Saturation Flow Rate	0.05	0.19	0.21	0.01	0.21	0.05	0.03	0.06	0.06	0.10	0.10	0.10
s, saturation flow rate [veh/h]	5134	3535	1580	3514	6863	2774	3459	3512	2752	5205	1870	1769
c, Capacity [veh/h]	845	1314	587	422	2247	908	548	662	1052	857	364	344
d1, Uniform Delay [s]	37.99	25.30	25.66	40.56	29.66	24.55	37.80	36.12	20.95	40.23	37.35	37.37
k, delay calibration	0.04	0.15	0.21	0.04	0.15	0.15	0.04	0.11	0.11	0.04	0.11	0.11
l, Upstream Filtering Factor	1.00	1.00	1.00	1.00	1.00	1.00	1.00	1.00	1.00	1.00	1.00	1.00
d2, Incremental Delay [s]	0.08	0.46	1.63	0.04	0.45	0.10	0.07	0.26	0.07	0.29	1.19	1.27
d3, Initial Queue Delay [s]	0.00	0.00	0.00	0.00	0.00	0.00	0.00	0.00	0.00	0.00	0.00	0.00
Rp, platoon ratio	1.00	1.00	1.00	1.00	1.00	1.00	1.00	1.00	1.00	1.00	1.00	1.00
PF, progression factor	1.00	1.00	1.00	1.00	1.00	1.00	1.00	1.00	1.00	1.00	1.00	1.00

**Lane Group Results**

X, volume / capacity	0.31	0.52	0.56	0.12	0.65	0.15	0.20	0.31	0.15	0.63	0.53	0.53
d, Delay for Lane Group [s/veh]	38.07	25.76	27.29	40.61	30.11	24.65	37.87	36.38	21.02	40.52	38.54	38.63
Lane Group LOS	D	C	C	D	C	C	D	D	C	D	D	D
Critical Lane Group	Yes	No	No	No	Yes	No	No	Yes	No	Yes	No	No
50th-Percentile Queue Length [veh/ln]	1.94	6.52	6.52	0.55	7.43	1.13	1.20	2.18	1.24	4.17	4.36	4.15
50th-Percentile Queue Length [ft/ln]	48.41	162.93	163.10	13.66	185.65	28.17	29.92	54.57	30.98	104.24	108.88	103.63
95th-Percentile Queue Length [veh/ln]	3.49	10.70	10.71	0.98	11.89	2.03	2.15	3.93	2.23	7.51	7.78	7.46
95th-Percentile Queue Length [ft/ln]	87.14	267.59	267.82	24.60	297.37	50.71	53.86	98.23	55.77	187.63	194.45	186.53



**Movement, Approach, & Intersection Results**

d_M, Delay for Movement [s/veh]	38.07	25.76	27.29	40.61	30.11	24.65	37.87	36.38	21.02	40.52	38.58	38.63
Movement LOS	D	C	C	D	C	C	D	D	C	D	D	D
d_A, Approach Delay [s/veh]	28.67			29.98			31.53			39.73		
Approach LOS	C			C			C			D		
d_I, Intersection Delay [s/veh]	31.84											
Intersection LOS	C											
Intersection V/C	0.481											

**Emissions**

Vehicle Miles Traveled [mph]	53.54	140.72	67.49	14.13	419.31	38.36	97.60	179.38	141.57	650.91	231.41	219.77
Stops [stops/h]	202.64	454.68	227.58	38.13	1036.15	78.62	83.50	152.29	86.46	436.35	151.93	144.60
Fuel consumption [US gal/h]	5.35	11.90	5.86	1.29	34.11	2.81	5.17	9.43	6.61	32.06	11.29	10.73
CO [g/h]	373.64	831.88	409.80	89.87	2384.15	196.66	361.51	659.29	461.97	2241.22	789.18	749.94
NOx [g/h]	72.70	161.85	79.73	17.49	463.87	38.26	70.34	128.27	89.88	436.06	153.54	145.91
VOC [g/h]	86.60	192.80	94.97	20.83	552.55	45.58	83.78	152.80	107.07	519.42	182.90	173.81

**Other Modes**

g_Walk,mi, Effective Walk Time [s]	-6.0			8.0			8.0			8.0		
M_corner, Corner Circulation Area [ft <sup>2</sup> /ped]	0.00			0.00			0.00			0.00		
M_CW, Crosswalk Circulation Area [ft <sup>2</sup> /ped]	0.00			0.00			0.00			0.00		
d_p, Pedestrian Delay [s]	57.77			43.91			43.91			43.91		
I_p,int, Pedestrian LOS Score for Intersectio	3.321			3.299			3.030			2.978		
Crosswalk LOS	C			C			C			C		
s_b, Saturation Flow Rate of the bicycle lane	2000			2000			2000			2000		
c_b, Capacity of the bicycle lane [bicycles/h]	678			678			678			678		
d_b, Bicycle Delay [s]	22.55			22.54			22.54			22.54		
I_b,int, Bicycle LOS Score for Intersection	2.612			2.234			1.952			2.315		
Bicycle LOS	B			B			A			B		

**Sequence**

Ring 1	1	2	3	4	-	-	-	-	-	-	-	-	-	-	-
Ring 2	5	6	7	8	-	-	-	-	-	-	-	-	-	-	-
Ring 3	-	-	-	-	-	-	-	-	-	-	-	-	-	-	-
Ring 4	-	-	-	-	-	-	-	-	-	-	-	-	-	-	-



**Intersection Level Of Service Report**  
**Intersection 4: Tassajara Road & I-580 WB Ramps**

Control Type:	Signalized	Delay (sec / veh):	13.2
Analysis Method:	HCM 7th Edition	Level Of Service:	B
Analysis Period:	15 minutes	Volume to Capacity (v/c):	0.587

**Intersection Setup**

Name	Tassajara Road		Tassajara Road		I-580 WB Ramps	
Approach	Northbound		Southbound		Westbound	
Lane Configuration	↑↑		↑↑↑		↔↔↔↔	
Turning Movement	Thru	Right	Left	Thru	Left	Right
Lane Width [ft]	12.00	12.00	12.00	12.00	12.00	12.00
No. of Lanes in Entry Pocket	0	0	0	0	1	1
Entry Pocket Length [ft]	100.00	100.00	100.00	100.00	100.00	100.00
No. of Lanes in Exit Pocket	0	1	0	0	0	0
Exit Pocket Length [ft]	0.00	49.21	0.00	0.00	0.00	0.00
Speed [mph]	30.00		30.00		30.00	
Grade [%]	0.00		0.00		0.00	
Curb Present	No		No		No	
Crosswalk	Yes		Yes		Yes	



**Volumes**

Name	Tassajara Road		Tassajara Road		I-580 WB Ramps	
Base Volume Input [veh/h]	1205	0	0	931	631	350
Base Volume Adjustment Factor	1.0000	1.0000	1.0000	1.0000	1.0000	1.0000
Heavy Vehicles Percentage [%]	2.30	2.00	2.00	1.80	2.90	4.00
Proportion of CAVs [%]	0.00					
Growth Factor	1.0000	1.0000	1.0000	1.0000	1.0000	1.0000
In-Process Volume [veh/h]	0	0	0	0	0	0
Site-Generated Trips [veh/h]	0	0	0	0	0	0
Diverted Trips [veh/h]	0	0	0	0	0	0
Pass-by Trips [veh/h]	0	0	0	0	0	0
Existing Site Adjustment Volume [veh/h]	0	0	0	0	0	0
Other Volume [veh/h]	0	0	0	0	0	0
Right Turn on Red Volume [veh/h]	0	0	0	0	0	0
Total Hourly Volume [veh/h]	1205	0	0	931	631	350
Peak Hour Factor	0.9800	1.0000	1.0000	0.9800	0.9800	0.9800
Other Adjustment Factor	1.0000	1.0000	1.0000	1.0000	1.0000	1.0000
Total 15-Minute Volume [veh/h]	307	0	0	238	161	89
Total Analysis Volume [veh/h]	1230	0	0	950	644	357
Presence of On-Street Parking	No	No	No	No	No	No
On-Street Parking Maneuver Rate [/h]	0	0	0	0	0	0
Local Bus Stopping Rate [/h]	0	0	0	0	0	0
v_do, Outbound Pedestrian Volume crossing	0		0		0	
v_di, Inbound Pedestrian Volume crossing m	0		0		0	
v_co, Outbound Pedestrian Volume crossing	0		0		0	
v_ci, Inbound Pedestrian Volume crossing mi	0		0		0	
v_ab, Corner Pedestrian Volume [ped/h]	0		0		0	
Bicycle Volume [bicycles/h]	0		0		0	





**Intersection Settings**

Located in CBD	No
Signal Coordination Group	-
Cycle Length [s]	60
Active Pattern	Pattern 1
Coordination Type	Time of Day Pattern Coordinated
Actuation Type	Fully actuated
Offset [s]	20.0
Offset Reference	Beginning of First Yellow
Permissive Mode	SingleBand
Lost time [s]	6.00

**Phasing & Timing (Basic)**

Control Type	Permissive	Permissive	Permissive	Permissive	Split	Split
Signal Group	6	0	0	2	4	0
Auxiliary Signal Groups						
Maximum Green [s]	40	0	0	40	20	0
Amber [s]	4.9	0.0	0.0	4.9	4.4	0.0
All red [s]	1.0	0.0	0.0	1.0	1.0	0.0
Walk [s]	5	0	0	0	0	0
Pedestrian Clearance [s]	16	0	0	0	0	0
Delayed Vehicle Green [s]	0.0	0.0	0.0	0.0	0.0	0.0
Rest In Walk	No			No	No	
I1, Start-Up Lost Time [s]	2.0	0.0	0.0	2.0	2.0	0.0
I2, Clearance Lost Time [s]	3.9	0.0	0.0	3.9	3.4	0.0
Detector Location [ft]	0.0	0.0	0.0	0.0	0.0	0.0
Detector Length [ft]	20.0	0.0	0.0	20.0	20.0	0.0
I, Upstream Filtering Factor	1.00	1.00	1.00	1.00	1.00	1.00

**Phasing & Timing: Pattern 1**

Split [s]	38	0	0	38	22	0
Lead / Lag	-	-	-	-	Lead	-
Minimum Green [s]	7	0	0	7	4	0
Vehicle Extension [s]	3.0	0.0	0.0	3.0	2.0	0.0
Minimum Recall	No			No	No	
Maximum Recall	Yes			Yes	No	
Pedestrian Recall	Yes			No	No	

**Exclusive Pedestrian Phase**

Pedestrian Signal Group	0
Pedestrian Walk [s]	0
Pedestrian Clearance [s]	0



**Lane Group Calculations**

Lane Group	C	C	L	R
C, Cycle Length [s]	66	66	66	66
L, Total Lost Time per Cycle [s]	5.90	5.90	5.40	5.40
l1_p, Permitted Start-Up Lost Time [s]	0.00	0.00	0.00	0.00
l2, Clearance Lost Time [s]	3.90	3.90	3.40	3.40
g_i, Effective Green Time [s]	40	40	15	15
g / C, Green / Cycle	0.61	0.61	0.22	0.22
(v / s)_i Volume / Saturation Flow Rate	0.35	0.19	0.19	0.13
s, saturation flow rate [veh/h]	3552	5102	3434	2768
c, Capacity [veh/h]	2151	3090	767	618
d1, Uniform Delay [s]	7.86	6.31	24.52	22.87
k, delay calibration	0.50	0.50	0.04	0.04
l, Upstream Filtering Factor	1.00	1.00	1.00	1.00
d2, Incremental Delay [s]	1.11	0.26	0.98	0.32
d3, Initial Queue Delay [s]	0.00	0.00	0.00	0.00
Rp, platoon ratio	1.00	1.00	1.00	1.00
PF, progression factor	1.00	1.00	1.00	1.00

**Lane Group Results**

X, volume / capacity	0.57	0.31	0.84	0.58
d, Delay for Lane Group [s/veh]	8.97	6.57	25.50	23.19
Lane Group LOS	A	A	C	C
Critical Lane Group	Yes	No	Yes	No
50th-Percentile Queue Length [veh/ln]	4.41	1.76	4.61	2.36
50th-Percentile Queue Length [ft/ln]	110.23	44.01	115.22	58.91
95th-Percentile Queue Length [veh/ln]	7.85	3.17	8.13	4.24
95th-Percentile Queue Length [ft/ln]	196.33	79.22	203.23	106.05

**Movement, Approach, & Intersection Results**

d_M, Delay for Movement [s/veh]	8.97	0.00	0.00	6.57	25.50	23.19
Movement LOS	A			A	C	C
d_A, Approach Delay [s/veh]	8.97		6.57		24.68	
Approach LOS	A		A		C	
d_I, Intersection Delay [s/veh]	13.19					
Intersection LOS	B					
Intersection V/C	0.587					

**Emissions**

Vehicle Miles Traveled [mph]	207.12	194.87	52.08	28.87
Stops [stops/h]	481.12	288.13	502.87	257.14
Fuel consumption [US gal/h]	13.43	10.88	8.26	4.29
CO [g/h]	938.71	760.82	577.66	300.16
NOx [g/h]	182.64	148.03	112.39	58.40
VOC [g/h]	217.56	176.33	133.88	69.56

**Other Modes**

g_Walk,mi, Effective Walk Time [s]	16.6	16.6	9.0
M_corner, Corner Circulation Area [ft <sup>2</sup> /ped]	0.00	0.00	0.00
M_CW, Crosswalk Circulation Area [ft <sup>2</sup> /ped]	0.00	0.00	0.00
d_p, Pedestrian Delay [s]	18.48	18.48	24.61
I_p,int, Pedestrian LOS Score for Intersectio	2.825	2.769	2.481
Crosswalk LOS	C	C	B
s_b, Saturation Flow Rate of the bicycle lane	2000	2000	2000
c_b, Capacity of the bicycle lane [bicycles/h]	973	973	503
d_b, Bicycle Delay [s]	8.70	8.70	18.48
I_b,int, Bicycle LOS Score for Intersection	2.574	2.082	1.560
Bicycle LOS	B	B	A

**Sequence**

Ring 1	-	2	-	4	-	-	-	-	-	-	-	-	-	-	-	-
Ring 2	-	6	-	-	-	-	-	-	-	-	-	-	-	-	-	-
Ring 3	-	-	-	-	-	-	-	-	-	-	-	-	-	-	-	-
Ring 4	-	-	-	-	-	-	-	-	-	-	-	-	-	-	-	-



**Intersection Level Of Service Report**  
**Intersection 5: Santa Rita Rd & I-580 EB Ramps/Pimlico Dr**

Control Type:	Signalized	Delay (sec / veh):	31.4
Analysis Method:	HCM 7th Edition	Level Of Service:	C
Analysis Period:	15 minutes	Volume to Capacity (v/c):	0.733

**Intersection Setup**

Name	Santa Rita Road			Tassajara Road			I-580 EB Ramps			Pimlico Drive		
Approach	Northbound			Southbound			Eastbound			Westbound		
Lane Configuration	↑			↵			↵↑			↵↵↵↑		
Turning Movement	Left	Thru	Right	Left	Thru	Right	Left	Thru	Right	Left	Thru	Right
Lane Width [ft]	12.00	12.00	12.00	12.00	12.00	12.00	12.00	12.00	12.00	12.00	12.00	12.00
No. of Lanes in Entry Pocket	0	0	1	1	0	0	1	0	0	2	0	1
Entry Pocket Length [ft]	100.00	100.00	250.00	425.00	100.00	100.00	625.00	100.00	100.00	200.00	100.00	250.00
No. of Lanes in Exit Pocket	0	0	0	0	0	2	0	0	0	0	0	0
Exit Pocket Length [ft]	0.00	0.00	0.00	0.00	0.00	49.21	0.00	0.00	0.00	0.00	0.00	0.00
Speed [mph]	30.00			30.00			30.00			30.00		
Grade [%]	0.00			0.00			0.00			0.00		
Curb Present	No			No			No			No		
Crosswalk	Yes			No			Yes			Yes		



**Volumes**

Name	Santa Rita Road			Tassajara Road			I-580 EB Ramps			Pimlico Drive		
Base Volume Input [veh/h]	0	937	84	164	1235	0	705	124	0	142	0	288
Base Volume Adjustment Factor	1.0000	1.0000	1.0000	1.0000	1.0000	1.0000	1.0000	1.0000	1.0000	1.0000	1.0000	1.0000
Heavy Vehicles Percentage [%]	2.00	3.30	2.40	1.80	2.30	2.00	2.10	2.40	2.00	0.70	2.00	2.40
Proportion of CAVs [%]	0.00											
Growth Factor	1.0000	1.0000	1.0000	1.0000	1.0000	1.0000	1.0000	1.0000	1.0000	1.0000	1.0000	1.0000
In-Process Volume [veh/h]	0	0	0	0	0	0	0	0	0	0	0	0
Site-Generated Trips [veh/h]	0	0	0	0	0	0	0	0	0	0	0	0
Diverted Trips [veh/h]	0	0	0	0	0	0	0	0	0	0	0	0
Pass-by Trips [veh/h]	0	0	0	0	0	0	0	0	0	0	0	0
Existing Site Adjustment Volume [veh/h]	0	0	0	0	0	0	0	0	0	0	0	0
Other Volume [veh/h]	0	0	0	0	0	0	0	0	0	0	0	0
Right Turn on Red Volume [veh/h]	0	0	0	0	0	0	0	0	0	0	0	0
Total Hourly Volume [veh/h]	0	937	84	164	1235	0	705	124	0	142	0	288
Peak Hour Factor	1.0000	0.9600	0.9600	0.9600	0.9600	1.0000	0.9600	0.9600	1.0000	0.9600	1.0000	0.9600
Other Adjustment Factor	1.0000	1.0000	1.0000	1.0000	1.0000	1.0000	1.0000	1.0000	1.0000	1.0000	1.0000	1.0000
Total 15-Minute Volume [veh/h]	0	244	22	43	322	0	184	32	0	37	0	75
Total Analysis Volume [veh/h]	0	976	88	171	1286	0	734	129	0	148	0	300
Presence of On-Street Parking	No		No	No		No	No		No	No		No
On-Street Parking Maneuver Rate [/h]	0	0	0	0	0	0	0	0	0	0	0	0
Local Bus Stopping Rate [/h]	0	0	0	0	0	0	0	0	0	0	0	0
v_do, Outbound Pedestrian Volume crossing	5			0			5			0		
v_di, Inbound Pedestrian Volume crossing m	5			0			5			0		
v_co, Outbound Pedestrian Volume crossing	0			2			2			1		
v_ci, Inbound Pedestrian Volume crossing mi	1			2			2			0		
v_ab, Corner Pedestrian Volume [ped/h]	0			0			0			0		
Bicycle Volume [bicycles/h]	0			0			0			0		



**Intersection Settings**

Located in CBD	No
Signal Coordination Group	-
Cycle Length [s]	120
Active Pattern	Pattern 1
Coordination Type	Time of Day Pattern Coordinated
Actuation Type	Fully actuated
Offset [s]	20.0
Offset Reference	Lead Green - Beginning of First Green
Permissive Mode	SingleBand
Lost time [s]	12.00

**Phasing & Timing (Basic)**

Control Type	Permiss	Permiss	Permiss	Protecte	Permiss	Permiss	Protecte	Permiss	Permiss	Permiss	Permiss	Overlap
Signal Group	0	6	0	5	2	0	3	8	0	7	0	4
Auxiliary Signal Groups												4,5
Maximum Green [s]	0	30	0	20	30	0	35	20	0	20	0	20
Amber [s]	0.0	4.4	0.0	3.0	4.4	0.0	4.4	4.4	0.0	3.5	0.0	3.5
All red [s]	0.0	1.0	0.0	1.0	1.0	0.0	1.0	1.0	0.0	1.0	0.0	1.0
Walk [s]	0	5	0	0	5	0	0	5	0	0	0	0
Pedestrian Clearance [s]	0	25	0	0	8	0	0	25	0	0	0	0
Delayed Vehicle Green [s]	0.0	0.0	0.0	0.0	0.0	0.0	0.0	0.0	0.0	0.0	0.0	0.0
Rest In Walk		No			No			No		No		
I1, Start-Up Lost Time [s]	0.0	2.0	0.0	2.0	2.0	0.0	2.0	2.0	0.0	2.0	0.0	2.0
I2, Clearance Lost Time [s]	0.0	3.4	0.0	2.0	3.4	0.0	3.4	3.4	0.0	2.5	0.0	2.5
Detector Location [ft]	0.0	0.0	0.0	0.0	0.0	0.0	0.0	0.0	0.0	0.0	0.0	0.0
Detector Length [ft]	0.0	20.0	0.0	20.0	20.0	0.0	20.0	20.0	0.0	20.0	0.0	0.0
I, Upstream Filtering Factor	1.00	1.00	1.00	1.00	1.00	1.00	1.00	1.00	1.00	1.00	1.00	1.00

**Phasing & Timing: Pattern 1**

Split [s]	0	41	0	25	66	0	40	36	0	18	0	14
Lead / Lag	-	-	-	Lead	-	-	Lead	-	-	Lead	-	-
Minimum Green [s]	0	7	0	5	7	0	5	5	0	5	0	5
Vehicle Extension [s]	0.0	3.0	0.0	3.0	3.0	0.0	3.0	2.0	0.0	3.0	0.0	2.0
Minimum Recall		No		No	No		No	No		No		No
Maximum Recall		Yes		No	Yes		No	No		No		No
Pedestrian Recall		No		No	Yes		No	No		No		No

**Exclusive Pedestrian Phase**

Pedestrian Signal Group	0
Pedestrian Walk [s]	0
Pedestrian Clearance [s]	0



**Lane Group Calculations**

Lane Group	C	C	L	C	L	C	L	R
C, Cycle Length [s]	120	120	120	120	120	120	120	120
L, Total Lost Time per Cycle [s]	5.40	5.40	4.00	5.40	5.40	5.40	4.50	4.00
l1_p, Permitted Start-Up Lost Time [s]	0.00	0.00	0.00	0.00	0.00	0.00	0.00	0.00
l2, Clearance Lost Time [s]	3.40	3.40	2.00	3.40	3.40	3.40	2.50	0.00
g_i, Effective Green Time [s]	53	53	14	70	29	27	7	24
g / C, Green / Cycle	0.44	0.44	0.12	0.59	0.24	0.22	0.06	0.20
(v / s)_i Volume / Saturation Flow Rate	0.20	0.15	0.10	0.36	0.21	0.07	0.04	0.11
s, saturation flow rate [veh/h]	4053	1748	1784	3552	3456	1864	3495	2804
c, Capacity [veh/h]	1778	767	206	2086	822	418	213	561
d1, Uniform Delay [s]	23.52	22.28	51.91	16.01	44.24	38.76	55.23	42.96
k, delay calibration	0.50	0.50	0.13	0.50	0.11	0.04	0.11	0.04
l, Upstream Filtering Factor	1.00	1.00	1.00	1.00	1.00	1.00	1.00	1.00
d2, Incremental Delay [s]	0.82	1.24	9.66	1.38	3.69	0.15	4.08	0.30
d3, Initial Queue Delay [s]	0.00	0.00	0.00	0.00	0.00	0.00	0.00	0.00
Rp, platoon ratio	1.00	1.00	1.00	1.00	1.00	1.00	1.00	1.00
PF, progression factor	1.00	1.00	1.00	1.00	1.00	1.00	1.00	1.00

**Lane Group Results**

X, volume / capacity	0.45	0.35	0.83	0.62	0.89	0.31	0.70	0.53
d, Delay for Lane Group [s/veh]	24.34	23.52	61.57	17.38	47.92	38.92	59.31	43.25
Lane Group LOS	C	C	E	B	D	D	E	D
Critical Lane Group	No	No	No	Yes	Yes	No	No	Yes
50th-Percentile Queue Length [veh/ln]	5.38	5.23	5.58	11.36	10.91	3.20	2.32	4.02
50th-Percentile Queue Length [ft/ln]	134.43	130.75	139.53	283.92	272.74	79.98	57.90	100.38
95th-Percentile Queue Length [veh/ln]	9.18	8.98	9.46	16.88	16.33	5.76	4.17	7.23
95th-Percentile Queue Length [ft/ln]	229.50	224.51	236.39	422.09	408.17	143.97	104.22	180.68

**Movement, Approach, & Intersection Results**

d_M, Delay for Movement [s/veh]	0.00	24.19	23.52	61.57	17.38	0.00	47.92	38.92	0.00	59.31	0.00	43.25
Movement LOS		C	C	E	B		D	D		E		D
d_A, Approach Delay [s/veh]	24.14			22.57			46.58			48.56		
Approach LOS	C			C			D			D		
d_I, Intersection Delay [s/veh]	31.45											
Intersection LOS	C											
Intersection V/C	0.733											

**Emissions**

Vehicle Miles Traveled [mph]	78.71	26.24	28.79	216.55	101.85	17.90	12.63	25.61
Stops [stops/h]	484.10	156.95	167.50	681.64	654.81	96.01	139.01	240.98
Fuel consumption [US gal/h]	9.87	3.22	4.25	17.23	14.97	2.29	3.07	5.03
CO [g/h]	689.74	225.10	297.28	1204.35	1046.26	159.99	214.87	351.30
NOx [g/h]	134.20	43.80	57.84	234.32	203.56	31.13	41.81	68.35
VOC [g/h]	159.86	52.17	68.90	279.12	242.48	37.08	49.80	81.42

**Other Modes**

g_Walk,mi, Effective Walk Time [s]	9.0		0.0		9.0		9.0
M_corner, Corner Circulation Area [ft <sup>2</sup> /ped]	0.00		0.00		0.00		0.00
M_CW, Crosswalk Circulation Area [ft <sup>2</sup> /ped]	653.31		0.00		0.00		0.00
d_p, Pedestrian Delay [s]	51.32		0.00		51.32		51.32
I_p,int, Pedestrian LOS Score for Intersectio	2.874		0.000		2.357		2.478
Crosswalk LOS	C		F		B		B
s_b, Saturation Flow Rate of the bicycle lane	2000		2000		2000		2000
c_b, Capacity of the bicycle lane [bicycles/h]	594		1010		510		225
d_b, Bicycle Delay [s]	29.66		14.69		33.28		47.24
I_b,int, Bicycle LOS Score for Intersection	1.999		2.762		2.984		1.560
Bicycle LOS	A		C		C		A

**Sequence**

Ring 1	-	2	3	4	-	-	-	-	-	-	-	-	-	-	-
Ring 2	5	6	7	8	-	-	-	-	-	-	-	-	-	-	-
Ring 3	-	-	-	-	-	-	-	-	-	-	-	-	-	-	-
Ring 4	-	-	-	-	-	-	-	-	-	-	-	-	-	-	-

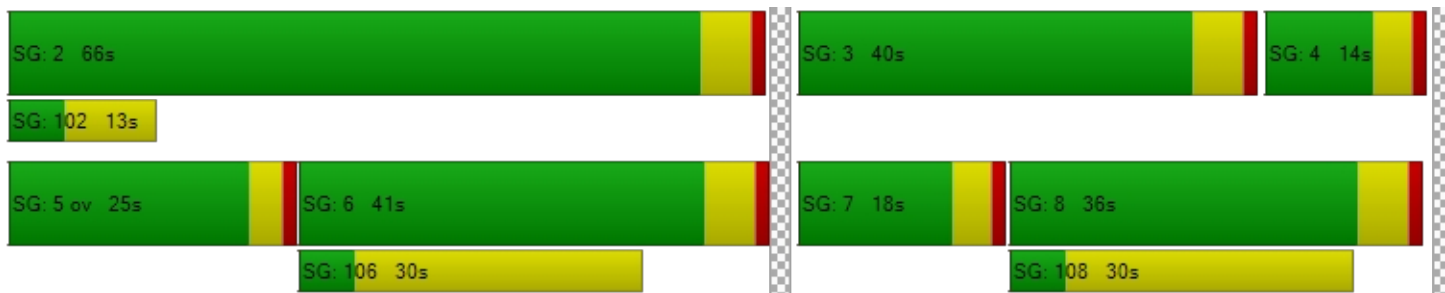



**Intersection Level Of Service Report**  
**Intersection 6: Tassajara Road & Fallon Road**

Control Type:	Signalized	Delay (sec / veh):	21.9
Analysis Method:	HCM 7th Edition	Level Of Service:	C
Analysis Period:	15 minutes	Volume to Capacity (v/c):	0.642

**Intersection Setup**

Name	Fallon Road			Fallon Road			Tassajara Road			Syrah Drive		
Approach	Northbound			Southbound			Eastbound			Westbound		
Lane Configuration												
Turning Movement	Left	Thru	Right	Left	Thru	Right	Left	Thru	Right	Left	Thru	Right
Lane Width [ft]	12.00	12.00	12.00	12.00	12.00	12.00	12.00	12.00	12.00	12.00	12.00	12.00
No. of Lanes in Entry Pocket	1	0	1	1	0	2	1	0	1	1	0	1
Entry Pocket Length [ft]	175.00	100.00	175.00	175.00	100.00	225.00	475.00	100.00	175.00	100.00	100.00	100.00
No. of Lanes in Exit Pocket	0	0	0	0	0	0	0	0	0	0	0	0
Exit Pocket Length [ft]	0.00	0.00	0.00	0.00	0.00	0.00	0.00	0.00	0.00	0.00	0.00	0.00
Speed [mph]	30.00			30.00			30.00			30.00		
Grade [%]	0.00			0.00			0.00			0.00		
Curb Present	No			No			No			No		
Crosswalk	Yes			Yes			Yes			Yes		



**Volumes**

Name	Fallon Road			Fallon Road			Tassajara Road			Syrah Drive		
Base Volume Input [veh/h]	197	239	12	2	320	460	217	12	206	18	33	8
Base Volume Adjustment Factor	1.0000	1.0000	1.0000	1.0000	1.0000	1.0000	1.0000	1.0000	1.0000	1.0000	1.0000	1.0000
Heavy Vehicles Percentage [%]	1.00	1.70	0.00	0.00	0.60	0.20	1.40	0.00	0.50	0.00	0.00	0.00
Proportion of CAVs [%]	0.00											
Growth Factor	1.0000	1.0000	1.0000	1.0000	1.0000	1.0000	1.0000	1.0000	1.0000	1.0000	1.0000	1.0000
In-Process Volume [veh/h]	0	0	0	0	0	0	0	0	0	0	0	0
Site-Generated Trips [veh/h]	0	0	0	0	0	0	0	0	0	0	0	0
Diverted Trips [veh/h]	0	0	0	0	0	0	0	0	0	0	0	0
Pass-by Trips [veh/h]	0	0	0	0	0	0	0	0	0	0	0	0
Existing Site Adjustment Volume [veh/h]	0	0	0	0	0	0	0	0	0	0	0	0
Other Volume [veh/h]	0	0	0	0	0	0	0	0	0	0	0	0
Right Turn on Red Volume [veh/h]	0	0	0	0	0	0	0	0	0	0	0	0
Total Hourly Volume [veh/h]	197	239	12	2	320	460	217	12	206	18	33	8
Peak Hour Factor	0.7800	0.7800	0.7800	0.7800	0.7800	0.7800	0.7800	0.7800	0.7800	0.7800	0.7800	0.7800
Other Adjustment Factor	1.0000	1.0000	1.0000	1.0000	1.0000	1.0000	1.0000	1.0000	1.0000	1.0000	1.0000	1.0000
Total 15-Minute Volume [veh/h]	63	77	4	1	103	147	70	4	66	6	11	3
Total Analysis Volume [veh/h]	253	306	15	3	410	590	278	15	264	23	42	10
Presence of On-Street Parking	No		No	No		No	No		No	No		No
On-Street Parking Maneuver Rate [/h]	0	0	0	0	0	0	0	0	0	0	0	0
Local Bus Stopping Rate [/h]	0	0	0	0	0	0	0	0	0	0	0	0
v_do, Outbound Pedestrian Volume crossing	1			0			0			0		
v_di, Inbound Pedestrian Volume crossing m	0			0			1			0		
v_co, Outbound Pedestrian Volume crossing	0			0			1			0		
v_ci, Inbound Pedestrian Volume crossing mi	0			1			0			0		
v_ab, Corner Pedestrian Volume [ped/h]	0			0			0			0		
Bicycle Volume [bicycles/h]	0			0			0			0		



**Intersection Settings**

Located in CBD	No
Signal Coordination Group	-
Cycle Length [s]	90
Active Pattern	Free Running (No Pattern)
Coordination Type	<i>Free Running</i>
Actuation Type	<i>Fully actuated</i>
Offset [s]	0.0
Offset Reference	Lead Green - Beginning of First Green
Permissive Mode	SingleBand
Lost time [s]	12.00

**Phasing & Timing (Basic)**

Control Type	Protecte	Permiss	Permiss	Protecte	Permiss	Permiss	Protecte	Permiss	Permiss	Protecte	Permiss	Permiss
Signal Group	3	8	0	7	4	0	5	2	0	1	6	0
Auxiliary Signal Groups												
Maximum Green [s]	25	50	0	25	50	0	35	30	0	20	30	0
Amber [s]	3.5	4.8	0.0	3.5	4.8	0.0	3.5	5.0	0.0	3.0	3.6	0.0
All red [s]	1.0	1.0	0.0	1.0	1.0	0.0	1.0	1.0	0.0	1.0	1.0	0.0
Walk [s]	0	4	0	0	0	0	0	4	0	0	3	0
Pedestrian Clearance [s]	0	25	0	0	0	0	0	28	0	0	36	0
Delayed Vehicle Green [s]	0.0	0.0	0.0	0.0	0.0	0.0	0.0	0.0	0.0	0.0	0.0	0.0
Rest In Walk		No			No			No			No	
I1, Start-Up Lost Time [s]	2.0	2.0	0.0	2.0	2.0	0.0	2.0	2.0	0.0	2.0	2.0	0.0
I2, Clearance Lost Time [s]	2.0	2.0	0.0	2.0	2.0	0.0	2.0	2.0	0.0	2.0	2.0	0.0
Detector Location [ft]	0.0	0.0	0.0	0.0	0.0	0.0	0.0	0.0	0.0	0.0	0.0	0.0
Detector Length [ft]	0.0	0.0	0.0	0.0	0.0	0.0	0.0	0.0	0.0	0.0	0.0	0.0
I, Upstream Filtering Factor	1.00	1.00	1.00	1.00	1.00	1.00	1.00	1.00	1.00	1.00	1.00	1.00

**Phasing & Timing: Free Running (No Pattern)**

Split [s]	0	0	0	0	0	0	0	0	0	0	0	0
Lead / Lag	Lead	-	-	Lead	-	-	Lead	-	-	Lead	-	-
Minimum Green [s]	9	10	0	9	10	0	11	8	0	12	9	0
Vehicle Extension [s]	3.0	3.0	0.0	3.0	3.0	0.0	3.0	3.0	0.0	3.0	3.0	0.0
Minimum Recall	No	No		No	No		Yes	No		No	No	
Maximum Recall	No	No		No	No		No	No		No	No	
Pedestrian Recall	No	No		No	No		No	No		No	No	

**Exclusive Pedestrian Phase**

Pedestrian Signal Group	0
Pedestrian Walk [s]	0
Pedestrian Clearance [s]	0



**Lane Group Calculations**

Lane Group	L	C	R	L	C	R	L	C	R	L	C	R
C, Cycle Length [s]	66	66	66	66	66	66	66	66	66	66	66	66
L, Total Lost Time per Cycle [s]	4.00	4.00	4.00	4.00	4.00	4.00	4.00	4.00	4.00	4.00	4.00	4.00
l1_p, Permitted Start-Up Lost Time [s]	0.00	0.00	0.00	0.00	0.00	0.00	0.00	0.00	0.00	0.00	0.00	0.00
l2, Clearance Lost Time [s]	2.00	2.00	2.00	2.00	2.00	2.00	2.00	2.00	2.00	2.00	2.00	2.00
g_i, Effective Green Time [s]	12	30	30	1	19	19	11	15	15	4	8	8
g / C, Green / Cycle	0.18	0.45	0.45	0.01	0.29	0.29	0.17	0.23	0.23	0.06	0.11	0.11
(v / s)_i Volume / Saturation Flow Rate	0.14	0.09	0.01	0.00	0.11	0.21	0.08	0.01	0.16	0.01	0.02	0.01
s, saturation flow rate [veh/h]	1795	3569	1615	1810	3600	2854	3475	1900	1606	1810	1900	1615
c, Capacity [veh/h]	322	1614	730	27	1035	821	605	430	363	114	219	186
d1, Uniform Delay [s]	25.73	10.78	9.95	31.92	18.81	21.02	24.35	19.82	23.53	29.20	26.29	25.87
k, delay calibration	0.11	0.11	0.11	0.11	0.11	0.11	0.11	0.11	0.11	0.11	0.11	0.11
l, Upstream Filtering Factor	1.00	1.00	1.00	1.00	1.00	1.00	1.00	1.00	1.00	1.00	1.00	1.00
d2, Incremental Delay [s]	4.21	0.06	0.01	1.78	0.25	1.20	0.55	0.03	2.78	0.86	0.42	0.12
d3, Initial Queue Delay [s]	0.00	0.00	0.00	0.00	0.00	0.00	0.00	0.00	0.00	0.00	0.00	0.00
Rp, platoon ratio	1.00	1.00	1.00	1.00	1.00	1.00	1.00	1.00	1.00	1.00	1.00	1.00
PF, progression factor	1.00	1.00	1.00	1.00	1.00	1.00	1.00	1.00	1.00	1.00	1.00	1.00

**Lane Group Results**

X, volume / capacity	0.78	0.19	0.02	0.11	0.40	0.72	0.46	0.03	0.73	0.20	0.19	0.05
d, Delay for Lane Group [s/veh]	29.95	10.84	9.96	33.70	19.06	22.22	24.90	19.86	26.31	30.06	26.71	25.99
Lane Group LOS	C	B	A	C	B	C	C	B	C	C	C	C
Critical Lane Group	Yes	No	No	No	No	Yes	No	No	Yes	Yes	No	No
50th-Percentile Queue Length [veh/ln]	3.93	1.20	0.11	0.06	2.37	3.89	1.88	0.17	3.82	0.36	0.59	0.14
50th-Percentile Queue Length [ft/ln]	98.17	30.00	2.74	1.46	59.23	97.20	47.01	4.33	95.48	8.93	14.85	3.48
95th-Percentile Queue Length [veh/ln]	7.07	2.16	0.20	0.11	4.26	7.00	3.38	0.31	6.87	0.64	1.07	0.25
95th-Percentile Queue Length [ft/ln]	176.71	53.99	4.94	2.64	106.61	174.96	84.62	7.80	171.87	16.08	26.73	6.27



**Movement, Approach, & Intersection Results**

d_M, Delay for Movement [s/veh]	29.95	10.84	9.96	33.70	19.06	22.22	24.90	19.86	26.31	30.06	26.71	25.99
Movement LOS	C	B	A	C	B	C	C	B	C	C	C	C
d_A, Approach Delay [s/veh]	19.24			20.96			25.43			27.64		
Approach LOS	B			C			C			C		
d_I, Intersection Delay [s/veh]	21.87											
Intersection LOS	C											
Intersection V/C	0.642											

**Emissions**

Vehicle Miles Traveled [mph]	24.11	29.16	1.43	0.33	44.50	64.04	35.85	1.93	34.05	0.83	1.51	0.36
Stops [stops/h]	215.73	131.83	6.03	3.22	260.29	427.20	206.61	9.52	209.82	19.63	32.63	7.65
Fuel consumption [US gal/h]	3.73	2.60	0.12	0.05	4.86	7.66	4.03	0.19	3.97	0.28	0.47	0.11
CO [g/h]	260.46	182.00	8.57	3.62	339.75	535.73	281.41	13.48	277.79	19.79	32.90	7.68
NOx [g/h]	50.68	35.41	1.67	0.70	66.10	104.23	54.75	2.62	54.05	3.85	6.40	1.50
VOC [g/h]	60.36	42.18	1.99	0.84	78.74	124.16	65.22	3.12	64.38	4.59	7.62	1.78

**Other Modes**

g_Walk,mi, Effective Walk Time [s]	8.0			7.0			-5.8			8.0		
M_corner, Corner Circulation Area [ft <sup>2</sup> /ped]	0.00			0.00			0.00			0.00		
M_CW, Crosswalk Circulation Area [ft <sup>2</sup> /ped]	0.00			0.00			0.00			0.00		
d_p, Pedestrian Delay [s]	25.25			26.14			38.82			25.25		
I_p,int, Pedestrian LOS Score for Intersectio	2.646			2.805			2.691			2.144		
Crosswalk LOS	B			C			B			B		
s_b, Saturation Flow Rate of the bicycle lane	2000			2000			2000			2000		
c_b, Capacity of the bicycle lane [bicycles/h]	1526			1526			916			916		
d_b, Bicycle Delay [s]	1.84			1.84			9.63			9.63		
I_b,int, Bicycle LOS Score for Intersection	2.033			2.387			2.479			1.683		
Bicycle LOS	B			B			B			A		

**Sequence**

Ring 1	1	2	3	4	-	-	-	-	-	-	-	-	-	-	-
Ring 2	5	6	7	8	-	-	-	-	-	-	-	-	-	-	-
Ring 3	-	-	-	-	-	-	-	-	-	-	-	-	-	-	-
Ring 4	-	-	-	-	-	-	-	-	-	-	-	-	-	-	-

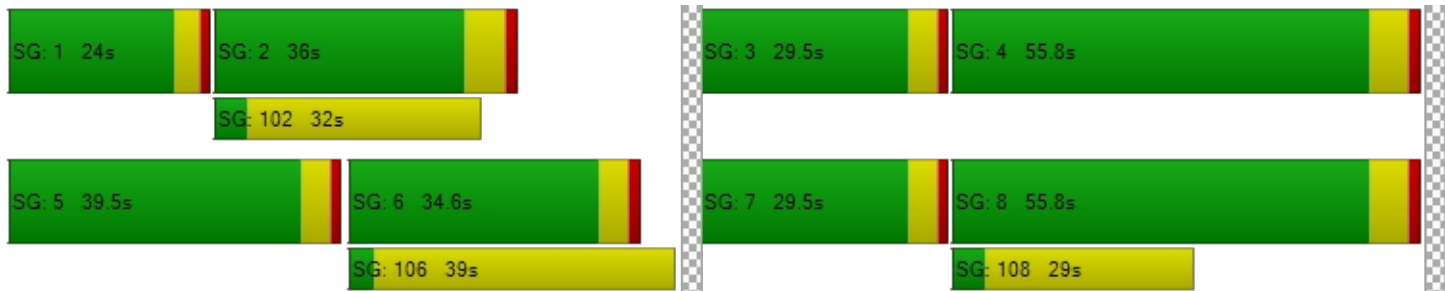

**Intersection Level Of Service Report**  
**Intersection 7: Fallon Road & Positano Parkway**

Control Type:	Signalized	Delay (sec / veh):	22.1
Analysis Method:	HCM 7th Edition	Level Of Service:	C
Analysis Period:	15 minutes	Volume to Capacity (v/c):	0.782

**Intersection Setup**

Name	Fallon Road		Fallon Road		Positano Parkway	
Approach	Northbound		Southbound		Westbound	
Lane Configuration	↑↑↑↔		↔↑↑↑		↔↔↔	
Turning Movement	Thru	Right	Left	Thru	Left	Right
Lane Width [ft]	12.00	12.00	12.00	12.00	12.00	12.00
No. of Lanes in Entry Pocket	0	1	1	0	1	1
Entry Pocket Length [ft]	100.00	225.00	325.00	100.00	375.00	425.00
No. of Lanes in Exit Pocket	0	0	0	0	0	0
Exit Pocket Length [ft]	0.00	0.00	0.00	0.00	0.00	0.00
Speed [mph]	30.00		30.00		30.00	
Grade [%]	0.00		0.00		0.00	
Curb Present	No		No		No	
Crosswalk	Yes		Yes		Yes	



**Volumes**

Name	Fallon Road		Fallon Road		Positano Parkway	
Base Volume Input [veh/h]	309	182	339	631	560	423
Base Volume Adjustment Factor	1.0000	1.0000	1.0000	1.0000	1.0000	1.0000
Heavy Vehicles Percentage [%]	2.90	0.50	0.30	0.60	0.00	0.70
Proportion of CAVs [%]	0.00					
Growth Factor	1.0000	1.0000	1.0000	1.0000	1.0000	1.0000
In-Process Volume [veh/h]	0	0	0	0	0	0
Site-Generated Trips [veh/h]	0	0	0	0	0	0
Diverted Trips [veh/h]	0	0	0	0	0	0
Pass-by Trips [veh/h]	0	0	0	0	0	0
Existing Site Adjustment Volume [veh/h]	0	0	0	0	0	0
Other Volume [veh/h]	0	0	0	0	0	0
Right Turn on Red Volume [veh/h]	0	0	0	0	0	0
Total Hourly Volume [veh/h]	309	182	339	631	560	423
Peak Hour Factor	0.8400	0.8400	0.8400	0.8400	0.8400	0.8400
Other Adjustment Factor	1.0000	1.0000	1.0000	1.0000	1.0000	1.0000
Total 15-Minute Volume [veh/h]	92	54	101	188	167	126
Total Analysis Volume [veh/h]	368	217	404	751	667	504
Presence of On-Street Parking	No	No	No	No	No	No
On-Street Parking Maneuver Rate [/h]	0	0	0	0	0	0
Local Bus Stopping Rate [/h]	0	0	0	0	0	0
v_do, Outbound Pedestrian Volume crossing	0		2		2	
v_di, Inbound Pedestrian Volume crossing m	0		2		2	
v_co, Outbound Pedestrian Volume crossing	0		0		1	
v_ci, Inbound Pedestrian Volume crossing mi	1		0		0	
v_ab, Corner Pedestrian Volume [ped/h]	0		0		0	
Bicycle Volume [bicycles/h]	0		0		2	

**Intersection Settings**

Located in CBD	No
Signal Coordination Group	-
Cycle Length [s]	90
Active Pattern	Free Running (No Pattern)
Coordination Type	<i>Free Running</i>
Actuation Type	<i>Fully actuated</i>
Offset [s]	0.0
Offset Reference	Lead Green - Beginning of First Green
Permissive Mode	SingleBand
Lost time [s]	9.00

**Phasing & Timing (Basic)**

Control Type	Permissive	Permissive	Protected	Permissive	Permissive	Permissive
Signal Group	4	0	7	8	6	0
Auxiliary Signal Groups						
Maximum Green [s]	30	0	20	30	24	0
Amber [s]	4.3	0.0	3.5	4.3	4.0	0.0
All red [s]	1.0	0.0	1.0	1.0	1.0	0.0
Walk [s]	0	0	0	4	4	0
Pedestrian Clearance [s]	0	0	0	20	34	0
Delayed Vehicle Green [s]	0.0	0.0	0.0	0.0	0.0	0.0
Rest In Walk	No			No	No	
I1, Start-Up Lost Time [s]	2.0	0.0	2.0	2.0	2.0	0.0
I2, Clearance Lost Time [s]	2.0	0.0	2.0	2.0	2.0	0.0
Detector Location [ft]	0.0	0.0	0.0	0.0	0.0	0.0
Detector Length [ft]	20.0	0.0	20.0	20.0	20.0	0.0
I, Upstream Filtering Factor	1.00	1.00	1.00	1.00	1.00	1.00

**Phasing & Timing: Free Running (No Pattern)**

Split [s]	14	0	9	14	9	0
Lead / Lag	-	-	Lead	-	Lead	-
Minimum Green [s]	10	0	5	10	5	0
Vehicle Extension [s]	3.0	0.0	3.0	3.0	3.0	0.0
Minimum Recall	Yes		No	Yes	No	
Maximum Recall	No		No	No	No	
Pedestrian Recall	No		No	No	No	

**Exclusive Pedestrian Phase**

Pedestrian Signal Group	0
Pedestrian Walk [s]	0
Pedestrian Clearance [s]	0





**Lane Group Calculations**

Lane Group	C	R	L	C	L	R
C, Cycle Length [s]	68	68	68	68	68	68
L, Total Lost Time per Cycle [s]	4.00	4.00	4.00	4.00	4.00	4.00
l1_p, Permitted Start-Up Lost Time [s]	0.00	0.00	0.00	0.00	0.00	0.00
l2, Clearance Lost Time [s]	2.00	2.00	2.00	2.00	2.00	2.00
g_i, Effective Green Time [s]	14	14	18	35	25	25
g / C, Green / Cycle	0.20	0.20	0.26	0.52	0.36	0.36
(v / s)_i Volume / Saturation Flow Rate	0.07	0.14	0.22	0.15	0.19	0.32
s, saturation flow rate [veh/h]	5057	1607	1805	5151	3514	1580
c, Capacity [veh/h]	1024	325	467	2679	1273	572
d1, Uniform Delay [s]	23.32	24.99	24.06	9.16	17.07	20.15
k, delay calibration	0.11	0.11	0.26	0.11	0.11	0.37
l, Upstream Filtering Factor	1.00	1.00	1.00	1.00	1.00	1.00
d2, Incremental Delay [s]	0.21	2.36	10.79	0.06	0.34	13.71
d3, Initial Queue Delay [s]	0.00	0.00	0.00	0.00	0.00	0.00
Rp, platoon ratio	1.00	1.00	1.00	1.00	1.00	1.00
PF, progression factor	1.00	1.00	1.00	1.00	1.00	1.00

**Lane Group Results**

X, volume / capacity	0.36	0.67	0.86	0.28	0.52	0.88
d, Delay for Lane Group [s/veh]	23.53	27.36	34.85	9.22	17.40	33.86
Lane Group LOS	C	C	C	A	B	C
Critical Lane Group	No	Yes	Yes	No	No	Yes
50th-Percentile Queue Length [veh/ln]	1.63	3.26	7.17	1.82	3.82	8.89
50th-Percentile Queue Length [ft/ln]	40.69	81.52	179.31	45.52	95.49	222.21
95th-Percentile Queue Length [veh/ln]	2.93	5.87	11.56	3.28	6.88	13.78
95th-Percentile Queue Length [ft/ln]	73.24	146.74	289.11	81.93	171.88	344.45



**Movement, Approach, & Intersection Results**

d_M, Delay for Movement [s/veh]	23.53	27.36	34.85	9.22	17.40	33.86
Movement LOS	C	C	C	A	B	C
d_A, Approach Delay [s/veh]	24.95		18.19		24.49	
Approach LOS	C		B		C	
d_I, Intersection Delay [s/veh]	22.08					
Intersection LOS	C					
Intersection V/C	0.782					

**Emissions**

Vehicle Miles Traveled [mph]	92.55	54.58	35.44	65.89	79.98	60.44
Stops [stops/h]	259.07	173.02	380.57	289.83	405.35	471.63
Fuel consumption [US gal/h]	7.00	4.41	6.43	5.72	7.89	8.57
CO [g/h]	489.57	308.31	449.24	400.05	551.81	598.79
NOx [g/h]	95.25	59.99	87.41	77.83	107.36	116.50
VOC [g/h]	113.46	71.45	104.12	92.71	127.89	138.78

**Other Modes**

g_Walk,mi, Effective Walk Time [s]	8.0		8.0		8.7	
M_corner, Corner Circulation Area [ft <sup>2</sup> /ped]	0.00		0.00		0.00	
M_CW, Crosswalk Circulation Area [ft <sup>2</sup> /ped]	0.00		0.00		0.00	
d_p, Pedestrian Delay [s]	26.39		26.39		25.78	
I_p,int, Pedestrian LOS Score for Intersectio	2.861		2.865		2.556	
Crosswalk LOS	C		C		B	
s_b, Saturation Flow Rate of the bicycle lane	2000		2000		2000	
c_b, Capacity of the bicycle lane [bicycles/h]	884		884		707	
d_b, Bicycle Delay [s]	10.56		10.56		14.18	
I_b,int, Bicycle LOS Score for Intersection	1.881		2.195		1.560	
Bicycle LOS	A		B		A	

**Sequence**

Ring 1	-	-	-	8	-	-	-	-	-	-	-	-	-	-	-	-
Ring 2	-	6	7	4	-	-	-	-	-	-	-	-	-	-	-	-
Ring 3	-	-	-	-	-	-	-	-	-	-	-	-	-	-	-	-
Ring 4	-	-	-	-	-	-	-	-	-	-	-	-	-	-	-	-



**Intersection Level Of Service Report**  
**Intersection 8: Fallon Road & Central Parkway**

Control Type:	Signalized	Delay (sec / veh):	31.9
Analysis Method:	HCM 7th Edition	Level Of Service:	C
Analysis Period:	15 minutes	Volume to Capacity (v/c):	0.567

**Intersection Setup**

Name	Fallon Road			Fallon Road			Central Parkway			Central Parkway		
Approach	Northbound			Southbound			Eastbound			Westbound		
Lane Configuration												
Turning Movement	Left	Thru	Right	Left	Thru	Right	Left	Thru	Right	Left	Thru	Right
Lane Width [ft]	12.00	12.00	12.00	12.00	12.00	12.00	12.00	12.00	12.00	12.00	12.00	12.00
No. of Lanes in Entry Pocket	2	0	1	1	0	1	2	0	2	2	0	1
Entry Pocket Length [ft]	300.00	100.00	255.00	295.00	100.00	245.00	350.00	100.00	230.00	250.00	100.00	250.00
No. of Lanes in Exit Pocket	0	0	1	0	0	2	0	0	0	0	0	0
Exit Pocket Length [ft]	0.00	0.00	250.00	0.00	0.00	500.00	0.00	0.00	0.00	0.00	0.00	0.00
Speed [mph]	40.00			30.00			25.00			30.00		
Grade [%]	0.00			0.00			0.00			0.00		
Curb Present	Yes			Yes			Yes			Yes		
Crosswalk	Yes			Yes			Yes			Yes		



**Volumes**

Name	Fallon Road			Fallon Road			Central Parkway			Central Parkway		
Base Volume Input [veh/h]	50	481	140	73	969	57	49	175	91	277	181	83
Base Volume Adjustment Factor	1.0000	1.0000	1.0000	1.0000	1.0000	1.0000	1.0000	1.0000	1.0000	1.0000	1.0000	1.0000
Heavy Vehicles Percentage [%]	6.00	1.20	0.70	0.00	0.40	1.80	0.00	0.60	3.30	0.00	0.60	1.20
Proportion of CAVs [%]	0.00											
Growth Factor	1.0000	1.0000	1.0000	1.0000	1.0000	1.0000	1.0000	1.0000	1.0000	1.0000	1.0000	1.0000
In-Process Volume [veh/h]	0	0	0	0	0	0	0	0	0	0	0	0
Site-Generated Trips [veh/h]	0	0	0	0	0	0	0	0	0	0	0	0
Diverted Trips [veh/h]	0	0	0	0	0	0	0	0	0	0	0	0
Pass-by Trips [veh/h]	0	0	0	0	0	0	0	0	0	0	0	0
Existing Site Adjustment Volume [veh/h]	0	0	0	0	0	0	0	0	0	0	0	0
Other Volume [veh/h]	0	0	0	0	0	0	0	0	0	0	0	0
Right Turn on Red Volume [veh/h]	0	0	0	0	0	0	0	0	0	0	0	0
Total Hourly Volume [veh/h]	50	481	140	73	969	57	49	175	91	277	181	83
Peak Hour Factor	0.7500	0.7500	0.7500	0.7500	0.7500	0.7500	0.7500	0.7500	0.7500	0.7500	0.7500	0.7500
Other Adjustment Factor	1.0000	1.0000	1.0000	1.0000	1.0000	1.0000	1.0000	1.0000	1.0000	1.0000	1.0000	1.0000
Total 15-Minute Volume [veh/h]	17	160	47	24	323	19	16	58	30	92	60	28
Total Analysis Volume [veh/h]	67	641	187	97	1292	76	65	233	121	369	241	111
Presence of On-Street Parking	No		No	No		No	No		No	No		No
On-Street Parking Maneuver Rate [/h]	0	0	0	0	0	0	0	0	0	0	0	0
Local Bus Stopping Rate [/h]	0	0	0	0	0	0	0	0	0	0	0	0
v_do, Outbound Pedestrian Volume crossing	1			2			2			1		
v_di, Inbound Pedestrian Volume crossing m	1			2			2			1		
v_co, Outbound Pedestrian Volume crossing	44			4			43			4		
v_ci, Inbound Pedestrian Volume crossing mi	43			4			44			4		
v_ab, Corner Pedestrian Volume [ped/h]	0			0			0			0		
Bicycle Volume [bicycles/h]	1			0			6			0		



**Intersection Settings**

Located in CBD	No
Signal Coordination Group	-
Cycle Length [s]	90
Active Pattern	Free Running (No Pattern)
Coordination Type	<i>Free Running</i>
Actuation Type	<i>Fully actuated</i>
Offset [s]	0.0
Offset Reference	Lead Green - Beginning of First Green
Permissive Mode	SingleBand
Lost time [s]	12.00

**Phasing & Timing (Basic)**

Control Type	Protecte	Permiss	Permiss	Protecte	Permiss	Permiss	Protecte	Permiss	Permiss	Protecte	Permiss	Permiss
Signal Group	3	8	0	7	4	0	5	2	0	1	6	0
Auxiliary Signal Groups												
Maximum Green [s]	20	30	0	20	30	0	20	30	0	20	30	0
Amber [s]	3.5	4.3	0.0	3.0	4.3	0.0	3.0	4.0	0.0	3.0	4.0	0.0
All red [s]	1.0	1.0	0.0	1.0	1.0	0.0	1.0	1.0	0.0	1.0	1.0	0.0
Walk [s]	0	4	0	0	4	0	0	4	0	0	4	0
Pedestrian Clearance [s]	0	28	0	0	34	0	0	42	0	0	41	0
Delayed Vehicle Green [s]	0.0	0.0	0.0	0.0	0.0	0.0	0.0	0.0	0.0	0.0	0.0	0.0
Rest In Walk		No			No			No			No	
I1, Start-Up Lost Time [s]	2.0	2.0	0.0	2.0	2.0	0.0	2.0	2.0	0.0	2.0	2.0	0.0
I2, Clearance Lost Time [s]	2.0	2.0	0.0	2.0	2.0	0.0	2.0	2.0	0.0	2.0	2.0	0.0
Detector Location [ft]	0.0	0.0	0.0	0.0	0.0	0.0	0.0	0.0	0.0	0.0	0.0	0.0
Detector Length [ft]	20.0	20.0	0.0	20.0	20.0	0.0	20.0	20.0	0.0	20.0	20.0	0.0
I, Upstream Filtering Factor	1.00	1.00	1.00	1.00	1.00	1.00	1.00	1.00	1.00	1.00	1.00	1.00

**Phasing & Timing: Free Running (No Pattern)**

Split [s]	0	0	0	0	0	0	0	0	0	0	0	0
Lead / Lag	Lead	-	-	Lead	-	-	Lead	-	-	Lead	-	-
Minimum Green [s]	10	12	0	10	12	0	10	12	0	10	12	0
Vehicle Extension [s]	2.0	4.0	0.0	2.0	4.0	0.0	2.0	4.0	0.0	2.0	4.0	0.0
Minimum Recall	No	Yes		No	Yes		No	No		No	No	
Maximum Recall	No	No		No	No		No	No		No	No	
Pedestrian Recall	No	No		No	No		No	No		No	No	

**Exclusive Pedestrian Phase**

Pedestrian Signal Group	0
Pedestrian Walk [s]	0
Pedestrian Clearance [s]	0



**Lane Group Calculations**

Lane Group	L	C	R	L	C	R	L	C	R	L	C	R
C, Cycle Length [s]	99	99	99	99	99	99	99	99	99	99	99	99
L, Total Lost Time per Cycle [s]	4.00	4.00	4.00	4.00	4.00	4.00	4.00	4.00	4.00	4.00	4.00	4.00
l1_p, Permitted Start-Up Lost Time [s]	0.00	0.00	0.00	0.00	0.00	0.00	0.00	0.00	0.00	0.00	0.00	0.00
l2, Clearance Lost Time [s]	2.00	2.00	2.00	2.00	2.00	2.00	2.00	2.00	2.00	2.00	2.00	2.00
g_i, Effective Green Time [s]	9	30	30	9	31	31	8	31	31	13	35	35
g / C, Green / Cycle	0.09	0.30	0.30	0.09	0.31	0.31	0.08	0.31	0.31	0.13	0.36	0.36
(v / s)_i Volume / Saturation Flow Rate	0.02	0.13	0.12	0.05	0.25	0.05	0.02	0.12	0.05	0.11	0.13	0.07
s, saturation flow rate [veh/h]	3348	5127	1567	1810	5159	1586	3514	1891	2512	3514	1891	1589
c, Capacity [veh/h]	305	1559	477	171	1588	488	299	589	782	453	672	564
d1, Uniform Delay [s]	41.96	27.54	27.27	43.10	31.81	25.04	42.44	26.91	24.67	42.19	23.71	22.24
k, delay calibration	0.04	0.15	0.15	0.04	0.15	0.15	0.04	0.15	0.15	0.04	0.15	0.15
l, Upstream Filtering Factor	1.00	1.00	1.00	1.00	1.00	1.00	1.00	1.00	1.00	1.00	1.00	1.00
d2, Incremental Delay [s]	0.13	0.25	0.75	1.09	1.50	0.21	0.13	0.61	0.13	1.37	0.46	0.24
d3, Initial Queue Delay [s]	0.00	0.00	0.00	0.00	0.00	0.00	0.00	0.00	0.00	0.00	0.00	0.00
Rp, platoon ratio	1.00	1.00	1.00	1.00	1.00	1.00	1.00	1.00	1.00	1.00	1.00	1.00
PF, progression factor	1.00	1.00	1.00	1.00	1.00	1.00	1.00	1.00	1.00	1.00	1.00	1.00

**Lane Group Results**

X, volume / capacity	0.22	0.41	0.39	0.57	0.81	0.16	0.22	0.40	0.15	0.81	0.36	0.20
d, Delay for Lane Group [s/veh]	42.09	27.79	28.02	44.19	33.31	25.25	42.57	27.53	24.80	43.57	24.18	22.48
Lane Group LOS	D	C	C	D	C	C	D	C	C	D	C	C
Critical Lane Group	Yes	No	No	No	Yes	No	No	Yes	No	Yes	No	No
50th-Percentile Queue Length [veh/ln]	0.75	3.91	3.46	2.32	9.53	1.32	0.75	4.44	1.05	4.45	4.20	1.81
50th-Percentile Queue Length [ft/ln]	18.73	97.73	86.40	57.93	238.36	33.06	18.84	110.93	26.16	111.23	104.96	45.34
95th-Percentile Queue Length [veh/ln]	1.35	7.04	6.22	4.17	14.60	2.38	1.36	7.89	1.88	7.91	7.56	3.26
95th-Percentile Queue Length [ft/ln]	33.71	175.91	155.52	104.28	364.96	59.50	33.92	197.30	47.08	197.72	188.93	81.61



**Movement, Approach, & Intersection Results**

d_M, Delay for Movement [s/veh]	42.09	27.79	28.02	44.19	33.31	25.25	42.57	27.53	24.80	43.57	24.18	22.48
Movement LOS	D	C	C	D	C	C	D	C	C	D	C	C
d_A, Approach Delay [s/veh]	28.91			33.61			29.07			33.84		
Approach LOS	C			C			C			C		
d_I, Intersection Delay [s/veh]	31.91											
Intersection LOS	C											
Intersection V/C	0.567											

**Emissions**

Vehicle Miles Traveled [mph]	17.74	169.72	49.51	24.40	324.95	19.11	5.68	20.36	10.58	83.89	54.79	25.23
Stops [stops/h]	54.31	425.08	125.27	84.00	1036.77	47.93	54.64	160.84	75.85	322.55	152.18	65.74
Fuel consumption [US gal/h]	1.74	13.88	4.07	2.34	27.86	1.44	1.03	2.84	1.38	8.51	4.28	1.91
CO [g/h]	121.82	970.21	284.53	163.61	1947.61	100.81	71.87	198.38	96.26	594.61	299.30	133.49
NOx [g/h]	23.70	188.77	55.36	31.83	378.93	19.61	13.98	38.60	18.73	115.69	58.23	25.97
VOC [g/h]	28.23	224.86	65.94	37.92	451.38	23.36	16.66	45.98	22.31	137.81	69.37	30.94

**Other Modes**

g_Walk,mi, Effective Walk Time [s]	8.0			8.0			8.0			8.0		
M_corner, Corner Circulation Area [ft <sup>2</sup> /ped]	0.00			0.00			0.00			0.00		
M_CW, Crosswalk Circulation Area [ft <sup>2</sup> /ped]	0.00			0.00			0.00			0.00		
d_p, Pedestrian Delay [s]	41.98			41.98			41.98			41.98		
I_p,int, Pedestrian LOS Score for Intersectio	3.243			3.196			2.694			2.548		
Crosswalk LOS	C			C			B			B		
s_b, Saturation Flow Rate of the bicycle lane	2000			2000			2000			2000		
c_b, Capacity of the bicycle lane [bicycles/h]	604			604			604			604		
d_b, Bicycle Delay [s]	24.20			24.19			24.26			24.19		
I_b,int, Bicycle LOS Score for Intersection	2.052			2.365			2.251			2.749		
Bicycle LOS	B			B			B			B		

**Sequence**

Ring 1	1	2	3	4	-	-	-	-	-	-	-	-	-	-	-
Ring 2	5	6	7	8	-	-	-	-	-	-	-	-	-	-	-
Ring 3	-	-	-	-	-	-	-	-	-	-	-	-	-	-	-
Ring 4	-	-	-	-	-	-	-	-	-	-	-	-	-	-	-

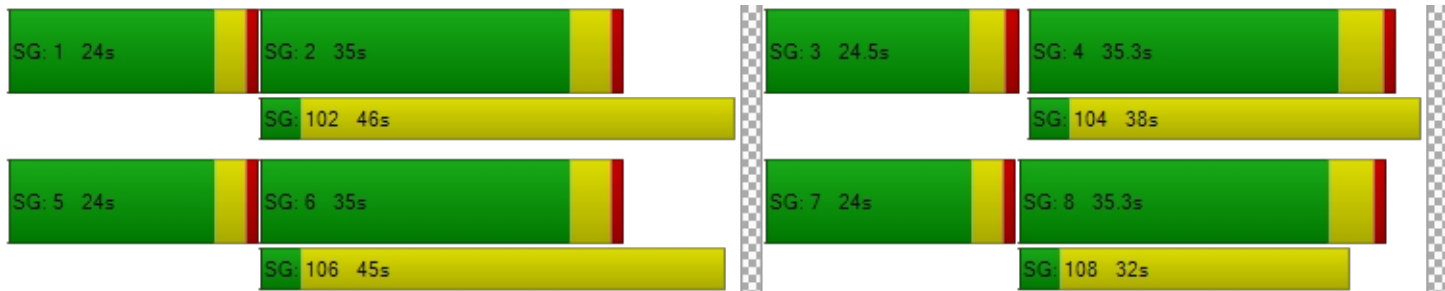

**Intersection Level Of Service Report**  
**Intersection 9: Fallon Road & Dublin Boulevard**

Control Type:	Signalized	Delay (sec / veh):	20.1
Analysis Method:	HCM 7th Edition	Level Of Service:	C
Analysis Period:	15 minutes	Volume to Capacity (v/c):	0.534

**Intersection Setup**

Name	Fallon Road			Fallon Road			Dublin Boulevard			Dublin Boulevard		
Approach	Northbound			Southbound			Eastbound			Westbound		
Lane Configuration	T T T			T T T			T T T T			T T		
Turning Movement	Left	Thru	Right	Left	Thru	Right	Left	Thru	Right	Left	Thru	Right
Lane Width [ft]	12.00	12.00	12.00	12.00	12.00	12.00	12.00	12.00	12.00	12.00	12.00	12.00
No. of Lanes in Entry Pocket	2	0	0	1	0	1	1	0	1	0	0	0
Entry Pocket Length [ft]	430.00	100.00	100.00	140.00	100.00	225.00	400.00	100.00	400.00	100.00	100.00	100.00
No. of Lanes in Exit Pocket	0	0	0	0	0	0	0	0	1	0	0	0
Exit Pocket Length [ft]	0.00	0.00	0.00	0.00	0.00	0.00	0.00	0.00	500.00	0.00	0.00	0.00
Speed [mph]	45.00			45.00			45.00			45.00		
Grade [%]	0.00			0.00			0.00			0.00		
Curb Present	Yes			Yes			Yes			Yes		
Crosswalk	No			No			Yes			Yes		





**Volumes**

Name	Fallon Road			Fallon Road			Dublin Boulevard			Dublin Boulevard		
Base Volume Input [veh/h]	226	500	0	0	1151	194	134	0	198	0	0	0
Base Volume Adjustment Factor	1.0000	1.0000	1.0000	1.0000	1.0000	1.0000	1.0000	1.0000	1.0000	1.0000	1.0000	1.0000
Heavy Vehicles Percentage [%]	3.50	1.20	4.00	1.00	0.50	0.00	0.70	4.00	3.50	1.00	1.00	1.00
Proportion of CAVs [%]	0.00											
Growth Factor	1.0000	1.0000	1.0000	1.0000	1.0000	1.0000	1.0000	1.0000	1.0000	1.0000	1.0000	1.0000
In-Process Volume [veh/h]	0	0	0	0	0	0	0	0	0	0	0	0
Site-Generated Trips [veh/h]	0	0	0	0	0	0	0	0	0	0	0	0
Diverted Trips [veh/h]	0	0	0	0	0	0	0	0	0	0	0	0
Pass-by Trips [veh/h]	0	0	0	0	0	0	0	0	0	0	0	0
Existing Site Adjustment Volume [veh/h]	0	0	0	0	0	0	0	0	0	0	0	0
Other Volume [veh/h]	0	0	0	0	0	0	0	0	0	0	0	0
Right Turn on Red Volume [veh/h]	0	0	0	0	0	0	0	0	0	0	0	0
Total Hourly Volume [veh/h]	226	500	0	0	1151	194	134	0	198	0	0	0
Peak Hour Factor	0.9200	0.9200	0.9400	0.9400	0.9200	0.9200	0.9200	0.9400	0.9200	0.9400	0.9400	0.9400
Other Adjustment Factor	1.0000	1.0000	1.0000	1.0000	1.0000	1.0000	1.0000	1.0000	1.0000	1.0000	1.0000	1.0000
Total 15-Minute Volume [veh/h]	61	136	0	0	313	53	36	0	54	0	0	0
Total Analysis Volume [veh/h]	246	543	0	0	1251	211	146	0	215	0	0	0
Presence of On-Street Parking	No		No	No		No	No		No	No		No
On-Street Parking Maneuver Rate [/h]	0	0	0	0	0	0	0	0	0	0	0	0
Local Bus Stopping Rate [/h]	0	0	0	0	0	0	0	0	0	0	0	0
v_do, Outbound Pedestrian Volume crossing	0			0			0			0		
v_di, Inbound Pedestrian Volume crossing m	0			0			0			0		
v_co, Outbound Pedestrian Volume crossing	2			4			4			3		
v_ci, Inbound Pedestrian Volume crossing mi	3			4			4			2		
v_ab, Corner Pedestrian Volume [ped/h]	0			0			0			0		
Bicycle Volume [bicycles/h]	0			0			0			0		



**Intersection Settings**

Located in CBD	No
Signal Coordination Group	-
Cycle Length [s]	140
Active Pattern	Pattern 1
Coordination Type	Time of Day Pattern Isolated
Actuation Type	Fully actuated
Offset [s]	0.0
Offset Reference	Lead Green - Beginning of First Green
Permissive Mode	SingleBand
Lost time [s]	12.00

**Phasing & Timing (Basic)**

Control Type	Protecte	Permiss	Permiss	Protecte	Permiss	Permiss	Protecte	Permiss	Overlap	Protecte	Permiss	Permiss
Signal Group	3	8	0	7	4	0	5	2	2	1	6	0
Auxiliary Signal Groups									2,3			
Maximum Green [s]	30	30	0	12	30	0	30	30	30	12	12	0
Amber [s]	4.3	4.7	0.0	4.3	4.7	0.0	4.3	4.3	4.3	3.0	4.8	0.0
All red [s]	1.0	1.0	0.0	1.0	1.0	0.0	1.0	1.0	1.0	1.0	1.0	0.0
Walk [s]	0	0	0	0	4	0	0	0	0	0	0	0
Pedestrian Clearance [s]	0	0	0	0	41	0	0	0	0	0	0	0
Delayed Vehicle Green [s]	0.0	0.0	0.0	0.0	0.0	0.0	0.0	0.0	0.0	0.0	0.0	0.0
Rest In Walk		No			No			No			No	
I1, Start-Up Lost Time [s]	2.0	2.0	0.0	2.0	2.0	0.0	2.0	2.0	2.0	2.0	2.0	0.0
I2, Clearance Lost Time [s]	2.0	2.0	0.0	2.0	2.0	0.0	2.0	2.0	2.0	2.0	2.0	0.0
Detector Location [ft]	0.0	0.0	0.0	0.0	0.0	0.0	0.0	0.0	0.0	0.0	0.0	0.0
Detector Length [ft]	20.0	20.0	0.0	20.0	20.0	0.0	0.0	0.0	0.0	20.0	20.0	0.0
I, Upstream Filtering Factor	1.00	1.00	1.00	1.00	1.00	1.00	1.00	1.00	1.00	1.00	1.00	1.00

**Phasing & Timing: Pattern 1**

Split [s]	35	65	0	20	50	0	35	35	35	20	20	0
Lead / Lag	Lead	-	-	Lead	-	-	Lead	-	-	Lead	-	-
Minimum Green [s]	10	12	0	10	12	0	10	12	12	10	10	0
Vehicle Extension [s]	2.0	4.0	0.0	2.0	4.0	0.0	2.0	4.0	4.0	2.0	2.0	0.0
Minimum Recall	No	Yes		No	Yes		No	No	No	No	No	
Maximum Recall	No	No		No	No		No	No	No	No	No	
Pedestrian Recall	No	No		No	No		No	No	No	No	No	

**Exclusive Pedestrian Phase**

Pedestrian Signal Group	0
Pedestrian Walk [s]	0
Pedestrian Clearance [s]	0



**Lane Group Calculations**

Lane Group	L	C	C	L	C	R	L	C	R	L	C
C, Cycle Length [s]	140	140	140	140	140	140	140	140	140	140	140
L, Total Lost Time per Cycle [s]	4.00	4.00	4.00	4.00	4.00	4.00	4.00	4.00	4.00	4.00	4.00
l1_p, Permitted Start-Up Lost Time [s]	0.00	0.00	0.00	0.00	0.00	0.00	0.00	0.00	0.00	0.00	0.00
l2, Clearance Lost Time [s]	2.00	2.00	2.00	2.00	2.00	2.00	2.00	2.00	0.00	2.00	2.00
g_i, Effective Green Time [s]	14	109	109	1	96	96	11	13	32	0	2
g / C, Green / Cycle	0.10	0.78	0.78	0.01	0.69	0.69	0.08	0.10	0.23	0.00	0.01
(v / s)_i Volume / Saturation Flow Rate	0.07	0.14	0.14	0.00	0.35	0.13	0.04	0.00	0.08	0.00	0.00
s, saturation flow rate [veh/h]	3417	1882	1882	1795	3603	1609	3495	1840	2780	1795	1885
c, Capacity [veh/h]	351	1469	1469	17	2477	1106	282	175	604	0	28
d1, Uniform Delay [s]	60.71	3.93	3.93	0.00	10.47	7.86	61.71	0.00	46.46	0.00	0.00
k, delay calibration	0.04	0.50	0.50	0.04	0.50	0.50	0.04	0.15	0.15	0.04	0.04
l, Upstream Filtering Factor	1.00	1.00	1.00	1.00	1.00	1.00	1.00	1.00	1.00	1.00	1.00
d2, Incremental Delay [s]	0.96	0.28	0.28	0.00	0.74	0.38	0.55	0.00	0.51	0.00	0.00
d3, Initial Queue Delay [s]	0.00	0.00	0.00	0.00	0.00	0.00	0.00	0.00	0.00	0.00	0.00
Rp, platoon ratio	1.00	1.00	1.00	1.00	1.00	1.00	1.00	1.00	1.00	1.00	1.00
PF, progression factor	1.00	1.00	1.00	1.00	1.00	1.00	1.00	1.00	1.00	1.00	1.00

**Lane Group Results**

X, volume / capacity	0.70	0.18	0.18	0.00	0.51	0.19	0.52	0.00	0.36	0.00	0.00
d, Delay for Lane Group [s/veh]	61.67	4.21	4.21	0.00	11.21	8.25	62.26	0.00	46.97	0.00	0.00
Lane Group LOS	E	A	A	A	B	A	E	A	D	A	A
Critical Lane Group	Yes	No	No	No	Yes	No	No	No	Yes	No	No
50th-Percentile Queue Length [veh/ln]	4.20	1.68	1.68	0.00	8.47	2.20	2.47	0.00	3.17	0.00	0.00
50th-Percentile Queue Length [ft/ln]	104.96	42.06	42.06	0.00	211.80	54.98	61.83	0.00	79.34	0.00	0.00
95th-Percentile Queue Length [veh/ln]	7.56	3.03	3.03	0.00	13.25	3.96	4.45	0.00	5.71	0.00	0.00
95th-Percentile Queue Length [ft/ln]	188.93	75.71	75.71	0.00	331.14	98.97	111.30	0.00	142.82	0.00	0.00



**Movement, Approach, & Intersection Results**

d_M, Delay for Movement [s/veh]	61.67	4.21	4.21	0.00	11.21	8.25	62.26	0.00	46.97	0.00	0.00	0.00
Movement LOS	E	A	A	A	B	A	E	A	D	A	A	A
d_A, Approach Delay [s/veh]	22.12			10.78			53.15			0.00		
Approach LOS	C			B			D			A		
d_I, Intersection Delay [s/veh]	20.06											
Intersection LOS	C											
Intersection V/C	0.534											

**Emissions**

Vehicle Miles Traveled [mph]	33.04	36.46	36.46	0.00	331.23	55.87	175.66	0.00	258.68	0.00	0.00
Stops [stops/h]	215.94	43.27	43.27	0.00	435.76	56.56	127.22	0.00	163.24	0.00	0.00
Fuel consumption [US gal/h]	6.90	2.02	2.02	0.00	19.63	2.97	9.45	0.00	12.95	0.00	0.00
CO [g/h]	482.59	141.22	141.22	0.00	1371.83	207.77	660.74	0.00	905.30	0.00	0.00
NOx [g/h]	93.89	27.48	27.48	0.00	266.91	40.42	128.56	0.00	176.14	0.00	0.00
VOC [g/h]	111.85	32.73	32.73	0.00	317.94	48.15	153.13	0.00	209.81	0.00	0.00

**Other Modes**

g_Walk,mi, Effective Walk Time [s]	0.0			0.0			8.0			59.3		
M_corner, Corner Circulation Area [ft <sup>2</sup> /ped]	0.00			0.00			0.00			0.00		
M_CW, Crosswalk Circulation Area [ft <sup>2</sup> /ped]	0.00			0.00			404.13			0.00		
d_p, Pedestrian Delay [s]	0.00			0.00			62.22			23.25		
I_p,int, Pedestrian LOS Score for Intersectio	0.000			0.000			2.898			2.115		
Crosswalk LOS	F			F			C			B		
s_b, Saturation Flow Rate of the bicycle lane	2000			2000			2000			2000		
c_b, Capacity of the bicycle lane [bicycles/h]	847			633			424			203		
d_b, Bicycle Delay [s]	23.25			32.70			43.44			56.51		
I_b,int, Bicycle LOS Score for Intersection	2.211			2.766			2.155			1.560		
Bicycle LOS	B			C			B			A		

**Sequence**

Ring 1	1	2	3	4	-	-	-	-	-	-	-	-	-	-	-
Ring 2	5	6	7	8	-	-	-	-	-	-	-	-	-	-	-
Ring 3	-	-	-	-	-	-	-	-	-	-	-	-	-	-	-
Ring 4	-	-	-	-	-	-	-	-	-	-	-	-	-	-	-



**Intersection Level Of Service Report**  
**Intersection 10: Fallon Road & Fallon Gateway**

Control Type:	Signalized	Delay (sec / veh):	13.3
Analysis Method:	HCM 7th Edition	Level Of Service:	B
Analysis Period:	15 minutes	Volume to Capacity (v/c):	0.526

**Intersection Setup**

Name	Fallon Road		Fallon Road		Fallon Gateway	
Approach	Northbound		Southbound		Eastbound	
Lane Configuration	↔ ↑ ↑		↑ ↔		↔↔↔↔	
Turning Movement	Left	Thru	Thru	Right	Left	Right
Lane Width [ft]	12.00	12.00	12.00	12.00	12.00	12.00
No. of Lanes in Entry Pocket	1	0	0	0	1	1
Entry Pocket Length [ft]	275.00	100.00	100.00	100.00	210.00	210.00
No. of Lanes in Exit Pocket	0	0	0	0	0	0
Exit Pocket Length [ft]	0.00	0.00	0.00	0.00	0.00	0.00
Speed [mph]	45.00		40.00		25.00	
Grade [%]	0.00		0.00		0.00	
Curb Present	Yes		Yes		Yes	
Crosswalk	No		No		Yes	



**Volumes**

Name	Fallon Road		Fallon Road		Fallon Gateway	
Base Volume Input [veh/h]	180	652	1178	42	20	94
Base Volume Adjustment Factor	1.0000	1.0000	1.0000	1.0000	1.0000	1.0000
Heavy Vehicles Percentage [%]	1.70	4.10	1.00	0.00	0.00	4.30
Proportion of CAVs [%]	0.00					
Growth Factor	1.0000	1.0000	1.0000	1.0000	1.0000	1.0000
In-Process Volume [veh/h]	0	0	0	0	0	0
Site-Generated Trips [veh/h]	0	0	0	0	0	0
Diverted Trips [veh/h]	0	0	0	0	0	0
Pass-by Trips [veh/h]	0	0	0	0	0	0
Existing Site Adjustment Volume [veh/h]	0	0	0	0	0	0
Other Volume [veh/h]	0	0	0	0	0	0
Right Turn on Red Volume [veh/h]	0	0	0	0	0	0
Total Hourly Volume [veh/h]	180	652	1178	42	20	94
Peak Hour Factor	0.9000	0.9000	0.9000	0.9000	0.9000	0.9000
Other Adjustment Factor	1.0000	1.0000	1.0000	1.0000	1.0000	1.0000
Total 15-Minute Volume [veh/h]	50	181	327	12	6	26
Total Analysis Volume [veh/h]	200	724	1309	47	22	104
Presence of On-Street Parking	No	No	No	No	No	No
On-Street Parking Maneuver Rate [/h]	0	0	0	0	0	0
Local Bus Stopping Rate [/h]	0	0	0	0	0	0
v_do, Outbound Pedestrian Volume crossing	0		0		0	
v_di, Inbound Pedestrian Volume crossing m	0		0		0	
v_co, Outbound Pedestrian Volume crossing	0		0		0	
v_ci, Inbound Pedestrian Volume crossing mi	0		0		0	
v_ab, Corner Pedestrian Volume [ped/h]	0		0		0	
Bicycle Volume [bicycles/h]	0		0		0	



**Intersection Settings**

Located in CBD	No
Signal Coordination Group	-
Cycle Length [s]	105
Active Pattern	Pattern 1
Coordination Type	Time of Day Pattern Isolated
Actuation Type	Fully actuated
Offset [s]	0.0
Offset Reference	Lead Green - Beginning of First Green
Permissive Mode	SingleBand
Lost time [s]	9.00

**Phasing & Timing (Basic)**

Control Type	Protected	Permissive	Permissive	Permissive	Permissive	Overlap
Signal Group	3	8	4	0	2	2
Auxiliary Signal Groups						2,3
Maximum Green [s]	20	40	40	0	30	30
Amber [s]	3.5	4.7	4.7	0.0	3.5	3.5
All red [s]	1.0	1.0	1.0	0.0	1.0	1.0
Walk [s]	0	0	4	0	0	0
Pedestrian Clearance [s]	0	0	28	0	0	0
Delayed Vehicle Green [s]	0.0	0.0	0.0	0.0	0.0	0.0
Rest In Walk		No	No		No	
I1, Start-Up Lost Time [s]	2.0	2.0	2.0	0.0	2.0	2.0
I2, Clearance Lost Time [s]	2.5	3.7	3.7	0.0	2.5	2.5
Detector Location [ft]	0.0	0.0	0.0	0.0	0.0	0.0
Detector Length [ft]	20.0	20.0	0.0	0.0	20.0	20.0
I, Upstream Filtering Factor	1.00	1.00	1.00	1.00	1.00	1.00

**Phasing & Timing: Pattern 1**

Split [s]	25	70	45	0	35	35
Lead / Lag	Lead	-	-	-	Lead	-
Minimum Green [s]	10	10	10	0	10	10
Vehicle Extension [s]	2.0	5.0	5.0	0.0	2.0	2.0
Minimum Recall	No	Yes	Yes		No	No
Maximum Recall	No	No	No		No	No
Pedestrian Recall	No	No	No		No	No

**Exclusive Pedestrian Phase**

Pedestrian Signal Group	0
Pedestrian Walk [s]	0
Pedestrian Clearance [s]	0



**Lane Group Calculations**

Lane Group	L	C	C	C	L	R
C, Cycle Length [s]	64	64	64	64	64	64
L, Total Lost Time per Cycle [s]	4.50	5.70	5.70	5.70	4.50	4.50
l1_p, Permitted Start-Up Lost Time [s]	0.00	0.00	0.00	0.00	0.00	0.00
l2, Clearance Lost Time [s]	2.50	3.70	3.70	3.70	2.50	0.00
g_i, Effective Green Time [s]	10	45	31	31	9	23
g / C, Green / Cycle	0.15	0.70	0.48	0.48	0.14	0.36
(v / s)_i Volume / Saturation Flow Rate	0.06	0.21	0.36	0.36	0.01	0.04
s, saturation flow rate [veh/h]	3467	3500	1885	1862	3514	2761
c, Capacity [veh/h]	525	2456	905	894	491	997
d1, Uniform Delay [s]	24.59	3.61	13.57	13.66	23.95	13.64
k, delay calibration	0.04	0.23	0.25	0.25	0.04	0.04
l, Upstream Filtering Factor	1.00	1.00	1.00	1.00	1.00	1.00
d2, Incremental Delay [s]	0.17	0.14	2.86	3.07	0.01	0.02
d3, Initial Queue Delay [s]	0.00	0.00	0.00	0.00	0.00	0.00
Rp, platoon ratio	1.00	1.00	1.00	1.00	1.00	1.00
PF, progression factor	1.00	1.00	1.00	1.00	1.00	1.00

**Lane Group Results**

X, volume / capacity	0.38	0.29	0.75	0.76	0.04	0.10
d, Delay for Lane Group [s/veh]	24.76	3.75	16.43	16.74	23.97	13.66
Lane Group LOS	C	A	B	B	C	B
Critical Lane Group	Yes	No	No	Yes	No	Yes
50th-Percentile Queue Length [veh/ln]	1.24	0.85	7.01	7.10	0.14	0.47
50th-Percentile Queue Length [ft/ln]	31.02	21.30	175.24	177.45	3.54	11.86
95th-Percentile Queue Length [veh/ln]	2.23	1.53	11.35	11.47	0.25	0.85
95th-Percentile Queue Length [ft/ln]	55.83	38.34	283.80	286.69	6.36	21.35



**Movement, Approach, & Intersection Results**

d_M, Delay for Movement [s/veh]	24.76	3.75	16.58	16.74	23.97	13.66
Movement LOS	C	A	B	B	C	B
d_A, Approach Delay [s/veh]	8.30		16.58		15.46	
Approach LOS	A		B		B	
d_I, Intersection Delay [s/veh]	13.34					
Intersection LOS	B					
Intersection V/C	0.526					

**Emissions**

Vehicle Miles Traveled [mph]	30.43	110.15	91.06	91.06	1.35	6.38
Stops [stops/h]	139.07	95.50	392.86	397.81	15.85	53.19
Fuel consumption [US gal/h]	3.78	5.52	9.39	9.48	0.23	0.78
CO [g/h]	264.21	385.57	656.22	662.61	15.99	54.53
NOx [g/h]	51.40	75.02	127.68	128.92	3.11	10.61
VOC [g/h]	61.23	89.36	152.09	153.57	3.71	12.64

**Other Modes**

g_Walk,mi, Effective Walk Time [s]	0.0		0.0		8.0	
M_corner, Corner Circulation Area [ft <sup>2</sup> /ped]	0.00		0.00		0.00	
M_CW, Crosswalk Circulation Area [ft <sup>2</sup> /ped]	0.00		0.00		0.00	
d_p, Pedestrian Delay [s]	0.00		0.00		24.62	
I_p,int, Pedestrian LOS Score for Intersectio	0.000		0.000		2.489	
Crosswalk LOS	F		F		B	
s_b, Saturation Flow Rate of the bicycle lane	2000		2000		2000	
c_b, Capacity of the bicycle lane [bicycles/h]	2002		1224		950	
d_b, Bicycle Delay [s]	0.00		4.84		8.86	
I_b,int, Bicycle LOS Score for Intersection	2.322		2.678		1.560	
Bicycle LOS	B		B		A	

**Sequence**

Ring 1	-	2	3	4	-	-	-	-	-	-	-	-	-	-	-	-
Ring 2	-	-	-	8	-	-	-	-	-	-	-	-	-	-	-	-
Ring 3	-	-	-	-	-	-	-	-	-	-	-	-	-	-	-	-
Ring 4	-	-	-	-	-	-	-	-	-	-	-	-	-	-	-	-



**Intersection Level Of Service Report**  
**Intersection 11: Fallon Road & I-580 WB Ramps**

Control Type:	Signalized	Delay (sec / veh):	8.2
Analysis Method:	HCM 7th Edition	Level Of Service:	A
Analysis Period:	15 minutes	Volume to Capacity (v/c):	0.765

**Intersection Setup**

Name	Fallon Road			Fallon Road			I-580 WB On-Ramp			I-580 WB Off-Ramp		
Approach	Northbound			Southbound			Eastbound			Westbound		
Lane Configuration	↑			↑↑↑						↑↑↑↑		
Turning Movement	Left	Thru	Right	Left	Thru	Right	Left	Thru	Right	Left	Thru	Right
Lane Width [ft]	12.00	12.00	12.00	12.00	12.00	12.00	12.00	12.00	12.00	12.00	12.00	12.00
No. of Lanes in Entry Pocket	0	0	0	0	0	1	0	0	0	1	0	1
Entry Pocket Length [ft]	100.00	100.00	100.00	100.00	100.00	225.00	100.00	100.00	100.00	170.00	100.00	130.00
No. of Lanes in Exit Pocket	0	0	1	0	0	0	0	0	1	0	0	0
Exit Pocket Length [ft]	0.00	0.00	400.00	0.00	0.00	0.00	0.00	0.00	400.00	0.00	0.00	0.00
Speed [mph]	45.00			40.00			30.00			35.00		
Grade [%]	0.00			0.00			0.00			0.00		
Curb Present	No			No						No		
Crosswalk	No			No			No			No		



**Volumes**

Name	Fallon Road			Fallon Road			I-580 WB On-Ramp			I-580 WB Off-Ramp		
	Base Volume Input [veh/h]	0	465	0	0	692	683	0	0	0	216	7
Base Volume Adjustment Factor	1.0000	1.0000	1.0000	1.0000	1.0000	1.0000	1.0000	1.0000	1.0000	1.0000	1.0000	1.0000
Heavy Vehicles Percentage [%]	2.00	0.60	2.00	2.00	1.90	0.40	2.00	2.00	2.00	4.20	0.00	4.00
Proportion of CAVs [%]	0.00											
Growth Factor	1.0000	1.0000	1.0000	1.0000	1.0000	1.0000	1.0000	1.0000	1.0000	1.0000	1.0000	1.0000
In-Process Volume [veh/h]	0	0	0	0	0	0	0	0	0	0	0	0
Site-Generated Trips [veh/h]	0	0	0	0	0	0	0	0	0	0	0	0
Diverted Trips [veh/h]	0	0	0	0	0	0	0	0	0	0	0	0
Pass-by Trips [veh/h]	0	0	0	0	0	0	0	0	0	0	0	0
Existing Site Adjustment Volume [veh/h]	0	0	0	0	0	0	0	0	0	0	0	0
Other Volume [veh/h]	0	0	0	0	0	0	0	0	0	0	0	0
Right Turn on Red Volume [veh/h]	0	0	0	0	0	0	0	0	0	0	0	0
Total Hourly Volume [veh/h]	0	465	0	0	692	683	0	0	0	216	7	471
Peak Hour Factor	1.0000	0.9500	1.0000	1.0000	0.9500	0.9500	1.0000	1.0000	1.0000	0.9500	0.9500	0.9500
Other Adjustment Factor	1.0000	1.0000	1.0000	1.0000	1.0000	1.0000	1.0000	1.0000	1.0000	1.0000	1.0000	1.0000
Total 15-Minute Volume [veh/h]	0	122	0	0	182	180	0	0	0	57	2	124
Total Analysis Volume [veh/h]	0	489	0	0	728	719	0	0	0	227	7	496
Presence of On-Street Parking	No		No	No		No				No		No
On-Street Parking Maneuver Rate [/h]	0	0	0	0	0	0	0	0	0	0	0	0
Local Bus Stopping Rate [/h]	0	0	0	0	0	0	0	0	0	0	0	0
v_do, Outbound Pedestrian Volume crossing	0			0			0			0		
v_di, Inbound Pedestrian Volume crossing m	0			0			0			0		
v_co, Outbound Pedestrian Volume crossing	0			0			0			0		
v_ci, Inbound Pedestrian Volume crossing mi	0			0			0			0		
v_ab, Corner Pedestrian Volume [ped/h]	0			0			0			0		
Bicycle Volume [bicycles/h]	0			0			0			0		



**Intersection Settings**

Located in CBD	No
Signal Coordination Group	-
Cycle Length [s]	90
Active Pattern	Free Running (No Pattern)
Coordination Type	<i>Free Running</i>
Actuation Type	<i>Fully actuated</i>
Offset [s]	0.0
Offset Reference	Lead Green - Beginning of First Green
Permissive Mode	SingleBand
Lost time [s]	9.00

**Phasing & Timing (Basic)**

Control Type	Permiss	Permiss	Permiss	Permiss	Permiss	Permiss	Permiss	Permiss	Permiss	Permiss	Permiss	Overlap
Signal Group	0	2	0	0	6	0	0	0	0	0	8	1
Auxiliary Signal Groups												1,8
Maximum Green [s]	0	35	0	0	35	0	0	0	0	0	20	15
Amber [s]	0.0	4.8	0.0	0.0	4.8	0.0	0.0	0.0	0.0	0.0	3.7	3.7
All red [s]	0.0	0.5	0.0	0.0	0.5	0.0	0.0	0.0	0.0	0.0	0.5	0.5
Walk [s]	0	0	0	0	0	0	0	0	0	0	0	0
Pedestrian Clearance [s]	0	0	0	0	0	0	0	0	0	0	0	0
Delayed Vehicle Green [s]	0.0	0.0	0.0	0.0	0.0	0.0	0.0	0.0	0.0	0.0	0.0	0.0
Rest In Walk		No			No						No	
I1, Start-Up Lost Time [s]	0.0	2.0	0.0	0.0	2.0	0.0	0.0	0.0	0.0	0.0	2.0	2.0
I2, Clearance Lost Time [s]	0.0	3.3	0.0	0.0	3.3	0.0	0.0	0.0	0.0	0.0	2.2	2.2
Detector Location [ft]	0.0	0.0	0.0	0.0	0.0	0.0	0.0	0.0	0.0	0.0	0.0	0.0
Detector Length [ft]	0.0	20.0	0.0	0.0	20.0	0.0	0.0	0.0	0.0	0.0	20.0	20.0
I, Upstream Filtering Factor	1.00	1.00	1.00	1.00	1.00	1.00	1.00	1.00	1.00	1.00	1.00	1.00

**Phasing & Timing: Free Running (No Pattern)**

Split [s]	0	0	0	0	0	0	0	0	0	0	0	0
Lead / Lag	-	-	-	-	-	-	-	-	-	-	-	-
Minimum Green [s]	0	10	0	0	10	0	0	0	0	0	5	4
Vehicle Extension [s]	0.0	0.0	0.0	0.0	0.0	0.0	0.0	0.0	0.0	0.0	0.0	0.0
Minimum Recall		Yes			Yes						No	No
Maximum Recall		No			No						No	No
Pedestrian Recall		No			No						No	No

**Exclusive Pedestrian Phase**

Pedestrian Signal Group	0
Pedestrian Walk [s]	0
Pedestrian Clearance [s]	0



**Lane Group Calculations**

Lane Group	C	C	R		L	C	R
C, Cycle Length [s]	38	38	38		38	38	38
L, Total Lost Time per Cycle [s]	5.30	5.30	5.30		4.20	4.20	4.20
l1_p, Permitted Start-Up Lost Time [s]	0.00	0.00	0.00		0.00	0.00	0.00
l2, Clearance Lost Time [s]	3.30	3.30	3.30		2.20	2.20	0.00
g_i, Effective Green Time [s]	11	22	22		7	7	17
g / C, Green / Cycle	0.30	0.58	0.58		0.17	0.17	0.45
(v / s)_i Volume / Saturation Flow Rate	0.26	0.20	0.45		0.07	0.07	0.18
s, saturation flow rate [veh/h]	1891	3563	1610		1749	1815	2768
c, Capacity [veh/h]	564	2066	934		303	314	1258
d1, Uniform Delay [s]	12.76	4.26	6.13		14.07	14.07	6.97
k, delay calibration	0.04	0.04	0.04		0.04	0.04	0.04
l, Upstream Filtering Factor	1.00	1.00	1.00		1.00	1.00	1.00
d2, Incremental Delay [s]	1.61	0.04	0.51		0.29	0.28	0.07
d3, Initial Queue Delay [s]	0.00	0.00	0.00		0.00	0.00	0.00
Rp, platoon ratio	1.00	1.00	1.00		1.00	1.00	1.00
PF, progression factor	1.00	1.00	1.00		1.00	1.00	1.00

**Lane Group Results**

X, volume / capacity	0.87	0.35	0.77		0.38	0.38	0.39
d, Delay for Lane Group [s/veh]	14.38	4.30	6.65		14.36	14.35	7.04
Lane Group LOS	B	A	A		B	B	A
Critical Lane Group	No	No	Yes		No	No	Yes
50th-Percentile Queue Length [veh/ln]	2.83	0.53	1.61		0.72	0.75	0.83
50th-Percentile Queue Length [ft/ln]	70.77	13.31	40.35		18.12	18.76	20.71
95th-Percentile Queue Length [veh/ln]	5.10	0.96	2.91		1.30	1.35	1.49
95th-Percentile Queue Length [ft/ln]	127.39	23.95	72.64		32.62	33.76	37.27

**Movement, Approach, & Intersection Results**

d_M, Delay for Movement [s/veh]	0.00	14.38	0.00	0.00	4.30	6.65	0.00	0.00	0.00	14.36	14.35	7.04
Movement LOS		B			A	A				B	B	A
d_A, Approach Delay [s/veh]	14.38		5.47			0.00			9.39			
Approach LOS	B		A			A			A			
d_I, Intersection Delay [s/veh]	8.17											
Intersection LOS	A											
Intersection V/C	0.765											

**Emissions**

Vehicle Miles Traveled [mph]	50.96	110.76	109.39		16.67	17.28	71.95
Stops [stops/h]	265.96	100.01	151.65		68.09	70.49	155.63
Fuel consumption [US gal/h]	6.48	5.59	6.38		1.48	1.54	4.62
CO [g/h]	453.27	390.56	446.01		103.69	107.41	323.24
NOx [g/h]	88.19	75.99	86.78		20.17	20.90	62.89
VOC [g/h]	105.05	90.52	103.37		24.03	24.89	74.91

**Other Modes**

g_Walk,mi, Effective Walk Time [s]	0.0	0.0	0.0	0.0
M_corner, Corner Circulation Area [ft <sup>2</sup> /ped]	0.00	0.00	0.00	0.00
M_CW, Crosswalk Circulation Area [ft <sup>2</sup> /ped]	0.00	0.00	0.00	0.00
d_p, Pedestrian Delay [s]	0.00	0.00	0.00	0.00
I_p,int, Pedestrian LOS Score for Intersectio	0.000	0.000	0.000	0.000
Crosswalk LOS	F	F	F	F
s_b, Saturation Flow Rate of the bicycle lane	2000	2000	2000	2000
c_b, Capacity of the bicycle lane [bicycles/h]	1827	1827	0	1044
d_b, Bicycle Delay [s]	0.14	0.14	19.16	4.38
I_b,int, Bicycle LOS Score for Intersection	2.366	2.753	4.132	2.764
Bicycle LOS	B	C	D	C

**Sequence**

Ring 1	1	2	-	-	-	-	-	-	-	-	-	-	-	-	-
Ring 2	-	6	-	8	-	-	-	-	-	-	-	-	-	-	-
Ring 3	-	-	-	-	-	-	-	-	-	-	-	-	-	-	-
Ring 4	-	-	-	-	-	-	-	-	-	-	-	-	-	-	-



**Intersection Level Of Service Report**  
**Intersection 12: El Charro Road & I-580 EB Ramps**

Control Type:	Signalized	Delay (sec / veh):	6.8
Analysis Method:	HCM 7th Edition	Level Of Service:	A
Analysis Period:	15 minutes	Volume to Capacity (v/c):	0.393

**Intersection Setup**

Name	El Charro Road			Fallon Road			I-580 EB Off-Ramp			I-580 EB On-Ramp		
Approach	Northbound			Southbound			Eastbound			Westbound		
Lane Configuration	↑↑			↑↑			↵↵↵↵					
Turning Movement	Left	Thru	Right	Left	Thru	Right	Left	Thru	Right	Left	Thru	Right
Lane Width [ft]	12.00	12.00	12.00	12.00	12.00	12.00	12.00	12.00	12.00	12.00	12.00	12.00
No. of Lanes in Entry Pocket	0	0	0	1	0	0	1	0	1	0	0	0
Entry Pocket Length [ft]	100.00	100.00	100.00	135.00	100.00	100.00	350.00	100.00	350.00	100.00	100.00	100.00
No. of Lanes in Exit Pocket	0	0	0	0	0	1	0	0	0	0	0	0
Exit Pocket Length [ft]	0.00	0.00	0.00	0.00	0.00	100.00	0.00	0.00	0.00	0.00	0.00	0.00
Speed [mph]	30.00			40.00			35.00			30.00		
Grade [%]	0.00			0.00			0.00			0.00		
Curb Present	No			No			No					
Crosswalk	No			No			No			Yes		



**Volumes**

Name	El Charro Road			Fallon Road			I-580 EB Off-Ramp			I-580 EB On-Ramp		
Base Volume Input [veh/h]	0	355	0	0	476	0	327	0	245	0	0	0
Base Volume Adjustment Factor	1.0000	1.0000	1.0000	1.0000	1.0000	1.0000	1.0000	1.0000	1.0000	1.0000	1.0000	1.0000
Heavy Vehicles Percentage [%]	2.00	10.40	2.00	2.00	2.70	2.00	0.90	2.00	10.60	2.00	2.00	2.00
Proportion of CAVs [%]	0.00											
Growth Factor	1.0000	1.0000	1.0000	1.0000	1.0000	1.0000	1.0000	1.0000	1.0000	1.0000	1.0000	1.0000
In-Process Volume [veh/h]	0	0	0	0	0	0	0	0	0	0	0	0
Site-Generated Trips [veh/h]	0	0	0	0	0	0	0	0	0	0	0	0
Diverted Trips [veh/h]	0	0	0	0	0	0	0	0	0	0	0	0
Pass-by Trips [veh/h]	0	0	0	0	0	0	0	0	0	0	0	0
Existing Site Adjustment Volume [veh/h]	0	0	0	0	0	0	0	0	0	0	0	0
Other Volume [veh/h]	0	0	0	0	0	0	0	0	0	0	0	0
Right Turn on Red Volume [veh/h]	0	0	0	0	0	0	0	0	0	0	0	0
Total Hourly Volume [veh/h]	0	355	0	0	476	0	327	0	245	0	0	0
Peak Hour Factor	1.0000	0.9300	1.0000	1.0000	0.9300	1.0000	0.9300	1.0000	0.9300	1.0000	1.0000	1.0000
Other Adjustment Factor	1.0000	1.0000	1.0000	1.0000	1.0000	1.0000	1.0000	1.0000	1.0000	1.0000	1.0000	1.0000
Total 15-Minute Volume [veh/h]	0	95	0	0	128	0	88	0	66	0	0	0
Total Analysis Volume [veh/h]	0	382	0	0	512	0	352	0	263	0	0	0
Presence of On-Street Parking	No		No	No		No	No		No			
On-Street Parking Maneuver Rate [/h]	0	0	0	0	0	0	0	0	0	0	0	0
Local Bus Stopping Rate [/h]	0	0	0	0	0	0	0	0	0	0	0	0
v_do, Outbound Pedestrian Volume crossing	0			0			0			0		
v_di, Inbound Pedestrian Volume crossing m	0			0			0			0		
v_co, Outbound Pedestrian Volume crossing	0			0			0			0		
v_ci, Inbound Pedestrian Volume crossing mi	0			0			0			0		
v_ab, Corner Pedestrian Volume [ped/h]	0			0			0			0		
Bicycle Volume [bicycles/h]	0			0			0			0		





**Intersection Settings**

Located in CBD	No
Signal Coordination Group	-
Cycle Length [s]	90
Active Pattern	Free Running (No Pattern)
Coordination Type	<i>Free Running</i>
Actuation Type	<i>Fully actuated</i>
Offset [s]	0.0
Offset Reference	Lead Green - Beginning of First Green
Permissive Mode	SingleBand
Lost time [s]	9.00

**Phasing & Timing (Basic)**

Control Type	Permiss	Permiss	Permiss	Permiss	Permiss	Permiss	Permiss	Permiss	Permiss	Permiss	Permiss	Permiss
Signal Group	0	2	0	0	6	0	4	0	0	0	0	0
Auxiliary Signal Groups												
Maximum Green [s]	0	40	0	0	40	0	26	0	0	0	0	0
Amber [s]	0.0	4.8	0.0	0.0	4.8	0.0	3.7	0.0	0.0	0.0	0.0	0.0
All red [s]	0.0	1.0	0.0	0.0	1.0	0.0	0.5	0.0	0.0	0.0	0.0	0.0
Walk [s]	0	0	0	0	0	0	0	0	0	0	0	0
Pedestrian Clearance [s]	0	0	0	0	0	0	0	0	0	0	0	0
Delayed Vehicle Green [s]	0.0	0.0	0.0	0.0	0.0	0.0	0.0	0.0	0.0	0.0	0.0	0.0
Rest In Walk		No			No		No					
I1, Start-Up Lost Time [s]	0.0	2.0	0.0	0.0	2.0	0.0	2.0	0.0	0.0	0.0	0.0	0.0
I2, Clearance Lost Time [s]	0.0	3.3	0.0	0.0	3.3	0.0	2.7	0.0	0.0	0.0	0.0	0.0
Detector Location [ft]	0.0	0.0	0.0	0.0	0.0	0.0	0.0	0.0	0.0	0.0	0.0	0.0
Detector Length [ft]	0.0	20.0	0.0	0.0	20.0	0.0	20.0	0.0	0.0	0.0	0.0	0.0
I, Upstream Filtering Factor	1.00	1.00	1.00	1.00	1.00	1.00	1.00	1.00	1.00	1.00	1.00	1.00

**Phasing & Timing: Free Running (No Pattern)**

Split [s]	0	0	0	0	0	0	0	0	0	0	0	0
Lead / Lag	-	-	-	-	-	-	Lead	-	-	-	-	-
Minimum Green [s]	0	10	0	0	10	0	4	0	0	0	0	0
Vehicle Extension [s]	0.0	0.0	0.0	0.0	0.0	0.0	0.0	0.0	0.0	0.0	0.0	0.0
Minimum Recall		Yes			Yes		No					
Maximum Recall		No			No		No					
Pedestrian Recall		No			No		No					

**Exclusive Pedestrian Phase**

Pedestrian Signal Group	0
Pedestrian Walk [s]	0
Pedestrian Clearance [s]	0



**Lane Group Calculations**

Lane Group	C	C	L	R	
C, Cycle Length [s]	24	24	24	24	
L, Total Lost Time per Cycle [s]	5.30	5.30	4.70	4.70	
l1_p, Permitted Start-Up Lost Time [s]	0.00	0.00	0.00	0.00	
l2, Clearance Lost Time [s]	3.30	3.30	2.70	2.70	
g_i, Effective Green Time [s]	10	10	4	4	
g / C, Green / Cycle	0.43	0.43	0.16	0.16	
(v / s)_i Volume / Saturation Flow Rate	0.12	0.14	0.10	0.10	
s, saturation flow rate [veh/h]	3320	3540	3489	2619	
c, Capacity [veh/h]	1414	1508	557	418	
d1, Uniform Delay [s]	4.49	4.65	9.47	9.47	
k, delay calibration	0.04	0.04	0.04	0.04	
l, Upstream Filtering Factor	1.00	1.00	1.00	1.00	
d2, Incremental Delay [s]	0.04	0.05	0.44	0.58	
d3, Initial Queue Delay [s]	0.00	0.00	0.00	0.00	
Rp, platoon ratio	1.00	1.00	1.00	1.00	
PF, progression factor	1.00	1.00	1.00	1.00	

**Lane Group Results**

X, volume / capacity	0.27	0.34	0.63	0.63	
d, Delay for Lane Group [s/veh]	4.53	4.70	9.92	10.05	
Lane Group LOS	A	A	A	B	
Critical Lane Group	No	Yes	Yes	No	
50th-Percentile Queue Length [veh/ln]	0.21	0.16	0.53	0.40	
50th-Percentile Queue Length [ft/ln]	5.29	3.95	13.13	10.01	
95th-Percentile Queue Length [veh/ln]	0.38	0.28	0.95	0.72	
95th-Percentile Queue Length [ft/ln]	9.53	7.10	23.63	18.01	

**Movement, Approach, & Intersection Results**

d_M, Delay for Movement [s/veh]	0.00	4.53	0.00	0.00	4.70	0.00	9.92	0.00	10.05	0.00	0.00	0.00
Movement LOS		A			A		A		B			
d_A, Approach Delay [s/veh]	4.53				4.70		9.98		0.00			
Approach LOS	A				A		A		A			
d_I, Intersection Delay [s/veh]	6.81											
Intersection LOS	A											
Intersection V/C	0.393											

**Emissions**

Vehicle Miles Traveled [mph]	65.76	50.29	40.90	30.56
Stops [stops/h]	63.47	47.32	157.41	120.02
Fuel consumption [US gal/h]	3.41	2.76	3.45	2.61
CO [g/h]	238.36	192.61	241.39	182.13
NOx [g/h]	46.38	37.47	46.97	35.44
VOC [g/h]	55.24	44.64	55.94	42.21

**Other Modes**

g_Walk,mi, Effective Walk Time [s]	0.0	0.0	0.0	-5.8
M_corner, Corner Circulation Area [ft <sup>2</sup> /ped]	0.00	0.00	0.00	0.00
M_CW, Crosswalk Circulation Area [ft <sup>2</sup> /ped]	0.00	0.00	0.00	0.00
d_p, Pedestrian Delay [s]	0.00	0.00	0.00	18.51
I_p,int, Pedestrian LOS Score for Intersectio	0.000	0.000	0.000	1.689
Crosswalk LOS	F	F	F	A
s_b, Saturation Flow Rate of the bicycle lane	2000	2000	2000	2000
c_b, Capacity of the bicycle lane [bicycles/h]	3331	3331	2165	0
d_b, Bicycle Delay [s]	5.32	5.32	0.08	12.01
I_b,int, Bicycle LOS Score for Intersection	1.875	1.982	1.560	4.132
Bicycle LOS	A	A	A	D

**Sequence**

Ring 1	-	2	-	4	-	-	-	-	-	-	-	-	-	-	-	-
Ring 2	-	6	-	-	-	-	-	-	-	-	-	-	-	-	-	-
Ring 3	-	-	-	-	-	-	-	-	-	-	-	-	-	-	-	-
Ring 4	-	-	-	-	-	-	-	-	-	-	-	-	-	-	-	-



**Intersection Level Of Service Report**  
**Intersection 13: El Charro Road & Jack London Boulevard**

Control Type:	Signalized	Delay (sec / veh):	10.5
Analysis Method:	HCM 7th Edition	Level Of Service:	B
Analysis Period:	15 minutes	Volume to Capacity (v/c):	0.291

**Intersection Setup**

Name	El Charro Road			El Charro Road			Stoneridge Drive			Jack London Boulevard		
Approach	Northbound			Southbound			Eastbound			Westbound		
Lane Configuration	TUT			TUT			TUT			TUT		
Turning Movement	Left	Thru	Right	Left	Thru	Right	Left	Thru	Right	Left	Thru	Right
Lane Width [ft]	12.00	12.00	12.00	12.00	12.00	12.00	12.00	12.00	12.00	12.00	12.00	12.00
No. of Lanes in Entry Pocket	1	0	2	2	0	1	3	0	1	1	0	2
Entry Pocket Length [ft]	125.00	100.00	175.00	650.00	100.00	450.00	450.00	100.00	325.00	400.00	100.00	775.00
No. of Lanes in Exit Pocket	0	0	0	0	0	1	1	0	0	0	0	0
Exit Pocket Length [ft]	0.00	0.00	0.00	0.00	0.00	49.21	450.00	0.00	0.00	0.00	0.00	0.00
Speed [mph]	30.00			30.00			30.00			30.00		
Grade [%]	0.00			0.00			0.00			0.00		
Curb Present	Yes			Yes			Yes			Yes		
Crosswalk	Yes			No			Yes			Yes		



**Volumes**

Name	El Charro Road			El Charro Road			Stoneridge Drive			Jack London Boulevard		
Base Volume Input [veh/h]	6	43	3	239	45	453	174	75	3	8	252	273
Base Volume Adjustment Factor	1.0000	1.0000	1.0000	1.0000	1.0000	1.0000	1.0000	1.0000	1.0000	1.0000	1.0000	1.0000
Heavy Vehicles Percentage [%]	0.00	86.00	33.30	0.40	66.70	0.20	2.30	5.30	0.00	37.50	1.20	1.10
Proportion of CAVs [%]	0.00											
Growth Factor	1.0000	1.0000	1.0000	1.0000	1.0000	1.0000	1.0000	1.0000	1.0000	1.0000	1.0000	1.0000
In-Process Volume [veh/h]	0	0	0	0	0	0	0	0	0	0	0	0
Site-Generated Trips [veh/h]	0	0	0	0	0	0	0	0	0	0	0	0
Diverted Trips [veh/h]	0	0	0	0	0	0	0	0	0	0	0	0
Pass-by Trips [veh/h]	0	0	0	0	0	0	0	0	0	0	0	0
Existing Site Adjustment Volume [veh/h]	0	0	0	0	0	0	0	0	0	0	0	0
Other Volume [veh/h]	0	0	0	0	0	0	0	0	0	0	0	0
Right Turn on Red Volume [veh/h]	0	0	0	0	0	0	0	0	0	0	0	0
Total Hourly Volume [veh/h]	6	43	3	239	45	453	174	75	3	8	252	273
Peak Hour Factor	0.8900	0.8900	0.8900	0.8900	0.8900	0.8900	0.8900	0.8900	0.8900	0.8900	0.8900	0.8900
Other Adjustment Factor	1.0000	1.0000	1.0000	1.0000	1.0000	1.0000	1.0000	1.0000	1.0000	1.0000	1.0000	1.0000
Total 15-Minute Volume [veh/h]	2	12	1	67	13	127	49	21	1	2	71	77
Total Analysis Volume [veh/h]	7	48	3	269	51	509	196	84	3	9	283	307
Presence of On-Street Parking	No		No	No		No	No		No	No		No
On-Street Parking Maneuver Rate [/h]	0	0	0	0	0	0	0	0	0	0	0	0
Local Bus Stopping Rate [/h]	0	0	0	0	0	0	0	0	0	0	0	0
v_do, Outbound Pedestrian Volume crossing	0			0			0			0		
v_di, Inbound Pedestrian Volume crossing m	0			0			0			0		
v_co, Outbound Pedestrian Volume crossing	0			0			0			1		
v_ci, Inbound Pedestrian Volume crossing mi	1			0			0			0		
v_ab, Corner Pedestrian Volume [ped/h]	0			0			0			0		
Bicycle Volume [bicycles/h]	0			0			1			0		



**Intersection Settings**

Located in CBD	No
Signal Coordination Group	-
Cycle Length [s]	90
Active Pattern	Free Running (No Pattern)
Coordination Type	<i>Free Running</i>
Actuation Type	<i>Fully actuated</i>
Offset [s]	0.0
Offset Reference	Lead Green - Beginning of First Green
Permissive Mode	SingleBand
Lost time [s]	12.00

**Phasing & Timing (Basic)**

Control Type	Protecte	Permiss	Permiss	Protecte	Permiss	Unsigna	Protecte	Permiss	Permiss	Protecte	Permiss	Overlap
Signal Group	7	4	0	3	8	0	1	6	0	5	2	2
Auxiliary Signal Groups												2,3
Maximum Green [s]	13	25	0	35	20	0	20	25	0	15	20	20
Amber [s]	3.0	5.0	0.0	3.0	4.3	0.0	3.0	4.3	0.0	3.0	4.3	4.3
All red [s]	1.0	1.0	0.0	1.0	1.0	0.0	1.0	1.0	0.0	1.0	1.0	1.0
Walk [s]	0	5	0	0	5	0	0	5	0	0	0	0
Pedestrian Clearance [s]	0	28	0	0	28	0	0	30	0	0	0	0
Delayed Vehicle Green [s]	0.0	0.0	0.0	0.0	0.0	0.0	0.0	0.0	0.0	0.0	0.0	0.0
Rest In Walk		No			No			No			No	
I1, Start-Up Lost Time [s]	2.0	2.0	0.0	2.0	2.0	0.0	2.0	2.0	0.0	2.0	2.0	2.0
I2, Clearance Lost Time [s]	2.0	2.0	0.0	2.0	2.0	0.0	2.0	2.0	0.0	2.0	2.0	2.0
Detector Location [ft]	0.0	0.0	0.0	0.0	0.0	0.0	0.0	0.0	0.0	0.0	0.0	0.0
Detector Length [ft]	20.0	20.0	0.0	20.0	20.0	0.0	20.0	20.0	0.0	0.0	0.0	0.0
I, Upstream Filtering Factor	1.00	1.00	1.00	1.00	1.00	1.00	1.00	1.00	1.00	1.00	1.00	1.00

**Phasing & Timing: Free Running (No Pattern)**

Split [s]	0	0	0	0	0	0	0	0	0	0	0	0
Lead / Lag	Lead	-	-	Lead	-	-	Lead	-	-	Lead	-	-
Minimum Green [s]	4	5	0	7	5	0	5	4	0	4	7	7
Vehicle Extension [s]	2.0	2.5	0.0	2.5	2.5	0.0	2.0	3.0	0.0	2.0	3.0	3.0
Minimum Recall	No	No		No	No		No	Yes		No	Yes	Yes
Maximum Recall	No	No		No	No		No	No		No	No	No
Pedestrian Recall	No	No		No	No		No	No		No	No	No

**Exclusive Pedestrian Phase**

Pedestrian Signal Group	0
Pedestrian Walk [s]	0
Pedestrian Clearance [s]	0



**Lane Group Calculations**

Lane Group	L	C	C	L	C	L	C	R	L	C	R
C, Cycle Length [s]	40	40	40	40	40	40	40	40	40	40	40
L, Total Lost Time per Cycle [s]	4.00	4.00	4.00	4.00	4.00	4.00	4.00	4.00	4.00	4.00	4.00
l1_p, Permitted Start-Up Lost Time [s]	0.00	0.00	0.00	0.00	0.00	0.00	0.00	0.00	0.00	0.00	0.00
l2, Clearance Lost Time [s]	2.00	2.00	2.00	2.00	2.00	2.00	2.00	2.00	2.00	2.00	0.00
g_i, Effective Green Time [s]	0	4	4	7	11	4	12	12	0	8	19
g / C, Green / Cycle	0.01	0.11	0.11	0.17	0.27	0.11	0.31	0.31	0.01	0.21	0.48
(v / s)_i Volume / Saturation Flow Rate	0.00	0.03	0.03	0.05	0.06	0.04	0.02	0.00	0.01	0.08	0.11
s, saturation flow rate [veh/h]	1810	1160	591	5254	899	5175	3466	1581	1273	3583	2834
c, Capacity [veh/h]	15	129	66	886	244	583	1075	490	14	746	1351
d1, Uniform Delay [s]	19.78	16.29	16.31	14.60	11.27	16.40	9.77	9.55	19.75	13.64	6.16
k, delay calibration	0.04	0.08	0.08	0.08	0.08	0.04	0.11	0.11	0.04	0.11	0.11
l, Upstream Filtering Factor	1.00	1.00	1.00	1.00	1.00	1.00	1.00	1.00	1.00	1.00	1.00
d2, Incremental Delay [s]	7.76	0.78	1.59	0.14	0.31	0.13	0.03	0.00	18.71	0.32	0.08
d3, Initial Queue Delay [s]	0.00	0.00	0.00	0.00	0.00	0.00	0.00	0.00	0.00	0.00	0.00
Rp, platoon ratio	1.00	1.00	1.00	1.00	1.00	1.00	1.00	1.00	1.00	1.00	1.00
PF, progression factor	1.00	1.00	1.00	1.00	1.00	1.00	1.00	1.00	1.00	1.00	1.00

**Lane Group Results**

X, volume / capacity	0.46	0.26	0.27	0.30	0.21	0.34	0.08	0.01	0.66	0.38	0.23
d, Delay for Lane Group [s/veh]	27.54	17.07	17.89	14.74	11.58	16.52	9.80	9.56	38.46	13.96	6.24
Lane Group LOS	C	B	B	B	B	B	A	A	D	B	A
Critical Lane Group	No	No	Yes	Yes	No	Yes	No	No	No	No	Yes
50th-Percentile Queue Length [veh/ln]	0.09	0.13	0.16	0.61	0.30	0.48	0.21	0.01	0.14	0.94	0.52
50th-Percentile Queue Length [ft/ln]	2.25	3.35	3.88	15.26	7.56	11.98	5.23	0.37	3.59	23.44	12.94
95th-Percentile Queue Length [veh/ln]	0.16	0.24	0.28	1.10	0.54	0.86	0.38	0.03	0.26	1.69	0.93
95th-Percentile Queue Length [ft/ln]	4.05	6.04	6.98	27.47	13.61	21.56	9.42	0.67	6.47	42.19	23.29



**Movement, Approach, & Intersection Results**

d_M, Delay for Movement [s/veh]	27.54	17.32	17.89	14.74	11.58	0.00	16.52	9.80	9.56	38.46	13.96	6.24
Movement LOS	C	B	B	B	B		B	A	A	D	B	A
d_A, Approach Delay [s/veh]	18.59			5.89			14.46			10.37		
Approach LOS	B			A			B			B		
d_I, Intersection Delay [s/veh]	10.53											
Intersection LOS	B											
Intersection V/C	0.291											

**Emissions**

Vehicle Miles Traveled [mph]	0.44	2.12	1.11	46.31	8.78	20.99	8.99	0.32	1.56	49.17	53.34
Stops [stops/h]	8.11	24.21	13.99	165.24	27.29	129.68	37.78	1.35	12.97	169.20	93.42
Fuel consumption [US gal/h]	0.10	0.34	0.19	3.63	0.63	2.24	0.75	0.03	0.21	3.76	3.10
CO [g/h]	7.15	23.59	13.07	253.47	44.21	156.55	52.19	1.85	14.43	263.02	216.81
NOx [g/h]	1.39	4.59	2.54	49.32	8.60	30.46	10.15	0.36	2.81	51.18	42.18
VOC [g/h]	1.66	5.47	3.03	58.74	10.25	36.28	12.10	0.43	3.35	60.96	50.25

**Other Modes**

g_Walk,mi, Effective Walk Time [s]	9.0			0.0			9.0			9.0		
M_corner, Corner Circulation Area [ft <sup>2</sup> /ped]	0.00			0.00			0.00			0.00		
M_CW, Crosswalk Circulation Area [ft <sup>2</sup> /ped]	0.00			0.00			0.00			0.00		
d_p, Pedestrian Delay [s]	11.96			0.00			11.96			11.96		
I_p,int, Pedestrian LOS Score for Intersectio	2.280			0.000			2.868			2.799		
Crosswalk LOS	B			F			C			C		
s_b, Saturation Flow Rate of the bicycle lane	2000			2000			2000			2000		
c_b, Capacity of the bicycle lane [bicycles/h]	1253			1003			1253			1003		
d_b, Bicycle Delay [s]	2.78			4.96			2.78			4.96		
I_b,int, Bicycle LOS Score for Intersection	1.592			2.088			1.793			2.054		
Bicycle LOS	A			B			A			B		

**Sequence**

Ring 1	1	2	3	4	-	-	-	-	-	-	-	-	-	-	-
Ring 2	5	6	7	8	-	-	-	-	-	-	-	-	-	-	-
Ring 3	-	-	-	-	-	-	-	-	-	-	-	-	-	-	-
Ring 4	-	-	-	-	-	-	-	-	-	-	-	-	-	-	-





**Intersection Level Of Service Report**  
**Intersection 14: Central Parkway & Sunset View Drive**

Control Type:	Signalized	Delay (sec / veh):	31.0
Analysis Method:	HCM 7th Edition	Level Of Service:	C
Analysis Period:	15 minutes	Volume to Capacity (v/c):	0.756

**Intersection Setup**

Name	Driveway			Sunset View Drive			Central Parkway			Central Parkway		
Approach	Northbound			Southbound			Eastbound			Westbound		
Lane Configuration	↵↵			↵↵			↵↵↵			↵↵		
Turning Movement	Left	Thru	Right	Left	Thru	Right	Left	Thru	Right	Left	Thru	Right
Lane Width [ft]	12.00	12.00	12.00	12.00	12.00	12.00	12.00	12.00	12.00	12.00	12.00	12.00
No. of Lanes in Entry Pocket	1	0	0	0	0	1	1	0	1	1	0	0
Entry Pocket Length [ft]	250.00	100.00	100.00	100.00	100.00	85.00	225.00	100.00	800.00	150.00	100.00	100.00
No. of Lanes in Exit Pocket	0	0	0	0	0	0	0	0	0	0	0	0
Exit Pocket Length [ft]	0.00	0.00	0.00	0.00	0.00	0.00	0.00	0.00	0.00	0.00	0.00	0.00
Speed [mph]	30.00			30.00			30.00			30.00		
Grade [%]	0.00			0.00			0.00			0.00		
Curb Present	No			No			No			No		
Crosswalk	Yes			Yes			Yes			Yes		



**Volumes**

Name	Driveway			Sunset View Drive			Central Parkway			Central Parkway		
Base Volume Input [veh/h]	146	17	6	17	15	149	40	173	167	16	232	2
Base Volume Adjustment Factor	1.0000	1.0000	1.0000	1.0000	1.0000	1.0000	1.0000	1.0000	1.0000	1.0000	1.0000	1.0000
Heavy Vehicles Percentage [%]	0.70	0.00	0.00	0.00	0.00	2.00	2.50	1.70	0.00	0.00	0.40	0.00
Proportion of CAVs [%]	0.00											
Growth Factor	1.0000	1.0000	1.0000	1.0000	1.0000	1.0000	1.0000	1.0000	1.0000	1.0000	1.0000	1.0000
In-Process Volume [veh/h]	0	0	0	0	0	0	0	0	0	0	0	0
Site-Generated Trips [veh/h]	0	0	0	0	0	0	0	0	0	0	0	0
Diverted Trips [veh/h]	0	0	0	0	0	0	0	0	0	0	0	0
Pass-by Trips [veh/h]	0	0	0	0	0	0	0	0	0	0	0	0
Existing Site Adjustment Volume [veh/h]	0	0	0	0	0	0	0	0	0	0	0	0
Other Volume [veh/h]	0	0	0	0	0	0	0	0	0	0	0	0
Right Turn on Red Volume [veh/h]	0	0	0	0	0	0	0	0	0	0	0	0
Total Hourly Volume [veh/h]	146	17	6	17	15	149	40	173	167	16	232	2
Peak Hour Factor	0.5500	0.5500	0.5500	0.5500	0.5500	0.5500	0.5500	0.5500	0.5500	0.5500	0.5500	0.5500
Other Adjustment Factor	1.0000	1.0000	1.0000	1.0000	1.0000	1.0000	1.0000	1.0000	1.0000	1.0000	1.0000	1.0000
Total 15-Minute Volume [veh/h]	66	8	3	8	7	68	18	79	76	7	105	1
Total Analysis Volume [veh/h]	265	31	11	31	27	271	73	315	304	29	422	4
Presence of On-Street Parking	No		No	No		No	No		No	No		No
On-Street Parking Maneuver Rate [/h]	0	0	0	0	0	0	0	0	0	0	0	0
Local Bus Stopping Rate [/h]	0	0	0	0	0	0	0	0	0	0	0	0
v_do, Outbound Pedestrian Volume crossing	74			14			74			14		
v_di, Inbound Pedestrian Volume crossing m	74			14			74			14		
v_co, Outbound Pedestrian Volume crossing	123			37			37			124		
v_ci, Inbound Pedestrian Volume crossing mi	124			37			37			123		
v_ab, Corner Pedestrian Volume [ped/h]	0			0			0			0		
Bicycle Volume [bicycles/h]	2			0			11			0		



**Intersection Settings**

Located in CBD	No
Signal Coordination Group	-
Cycle Length [s]	90
Active Pattern	Free Running (No Pattern)
Coordination Type	<i>Free Running</i>
Actuation Type	<i>Fully actuated</i>
Offset [s]	0.0
Offset Reference	Lead Green - Beginning of First Green
Permissive Mode	SingleBand
Lost time [s]	12.00

**Phasing & Timing (Basic)**

Control Type	Protecte	Permiss	Permiss	Protecte	Permiss	Permiss	Protecte	Permiss	Permiss	Protecte	Permiss	Permiss
Signal Group	3	8	0	7	4	0	5	2	0	1	6	0
Auxiliary Signal Groups												
Maximum Green [s]	30	30	0	20	20	0	20	25	0	20	25	0
Amber [s]	3.0	3.0	0.0	3.0	3.0	0.0	3.0	3.6	0.0	3.0	3.6	0.0
All red [s]	1.0	1.0	0.0	1.0	1.0	0.0	1.0	1.0	0.0	1.0	1.0	0.0
Walk [s]	0	4	0	0	4	0	0	4	0	0	4	0
Pedestrian Clearance [s]	0	24	0	0	21	0	0	16	0	0	17	0
Delayed Vehicle Green [s]	0.0	0.0	0.0	0.0	0.0	0.0	0.0	0.0	0.0	0.0	0.0	0.0
Rest In Walk		No			No			No			No	
I1, Start-Up Lost Time [s]	2.0	2.0	0.0	2.0	2.0	0.0	2.0	2.0	0.0	2.0	2.0	0.0
I2, Clearance Lost Time [s]	2.0	2.0	0.0	2.0	2.0	0.0	2.0	2.0	0.0	2.0	2.0	0.0
Detector Location [ft]	0.0	0.0	0.0	0.0	0.0	0.0	0.0	0.0	0.0	0.0	0.0	0.0
Detector Length [ft]	20.0	20.0	0.0	20.0	20.0	0.0	20.0	20.0	0.0	20.0	20.0	0.0
I, Upstream Filtering Factor	1.00	1.00	1.00	1.00	1.00	1.00	1.00	1.00	1.00	1.00	1.00	1.00

**Phasing & Timing: Free Running (No Pattern)**

Split [s]	9	14	0	9	14	0	9	14	0	9	14	0
Lead / Lag	Lead	-	-	Lead	-	-	Lead	-	-	Lead	-	-
Minimum Green [s]	5	10	0	5	10	0	5	10	0	5	10	0
Vehicle Extension [s]	2.0	4.0	0.0	2.0	4.0	0.0	2.0	4.0	0.0	2.0	4.0	0.0
Minimum Recall	No	No		No	No		No	Yes		No	Yes	
Maximum Recall	No	No		No	No		No	No		No	No	
Pedestrian Recall	No	No		No	No		No	No		No	No	

**Exclusive Pedestrian Phase**

Pedestrian Signal Group	0
Pedestrian Walk [s]	0
Pedestrian Clearance [s]	0



**Lane Group Calculations**

Lane Group	L	C	L	C	L	C	R	L	C
C, Cycle Length [s]	73	73	73	73	73	73	73	73	73
L, Total Lost Time per Cycle [s]	4.00	4.00	4.00	4.00	4.00	4.00	4.00	4.00	4.00
l1_p, Permitted Start-Up Lost Time [s]	0.00	0.00	0.00	0.00	0.00	0.00	0.00	0.00	0.00
l2, Clearance Lost Time [s]	2.00	2.00	2.00	2.00	2.00	2.00	2.00	2.00	2.00
g_i, Effective Green Time [s]	13	30	2	20	4	22	22	2	20
g / C, Green / Cycle	0.18	0.42	0.03	0.28	0.05	0.30	0.30	0.03	0.27
(v / s)_i Volume / Saturation Flow Rate	0.15	0.03	0.02	0.21	0.04	0.17	0.26	0.02	0.23
s, saturation flow rate [veh/h]	1800	1603	1810	1432	1774	1874	1173	1810	1890
c, Capacity [veh/h]	316	671	59	394	96	559	350	56	519
d1, Uniform Delay [s]	28.96	12.63	34.60	24.11	33.91	21.53	22.06	34.67	24.67
k, delay calibration	0.04	0.15	0.04	0.28	0.04	0.15	0.29	0.04	0.23
l, Upstream Filtering Factor	1.00	1.00	1.00	1.00	1.00	1.00	1.00	1.00	1.00
d2, Incremental Delay [s]	2.30	0.06	2.68	7.52	4.59	1.28	15.76	2.71	6.65
d3, Initial Queue Delay [s]	0.00	0.00	0.00	0.00	0.00	0.00	0.00	0.00	0.00
Rp, platoon ratio	1.00	1.00	1.00	1.00	1.00	1.00	1.00	1.00	1.00
PF, progression factor	1.00	1.00	1.00	1.00	1.00	1.00	1.00	1.00	1.00

**Lane Group Results**

X, volume / capacity	0.84	0.06	0.53	0.76	0.76	0.56	0.87	0.52	0.82
d, Delay for Lane Group [s/veh]	31.25	12.68	37.29	31.63	38.50	22.80	37.83	37.38	31.32
Lane Group LOS	C	B	D	C	D	C	D	D	C
Critical Lane Group	Yes	No	No	Yes	No	No	Yes	Yes	No
50th-Percentile Queue Length [veh/ln]	4.47	0.39	0.57	5.23	1.35	4.46	5.75	0.53	7.41
50th-Percentile Queue Length [ft/ln]	111.70	9.77	14.19	130.65	33.84	111.57	143.72	13.31	185.22
95th-Percentile Queue Length [veh/ln]	7.93	0.70	1.02	8.98	2.44	7.93	9.68	0.96	11.87
95th-Percentile Queue Length [ft/ln]	198.36	17.59	25.54	224.38	60.91	198.19	242.03	23.96	296.82

**Movement, Approach, & Intersection Results**

d_M, Delay for Movement [s/veh]	31.25	12.68	12.68	37.29	31.63	31.63	38.50	22.80	37.83	37.38	31.32	31.32
Movement LOS	C	B	B	D	C	C	D	C	D	D	C	C
d_A, Approach Delay [s/veh]	28.71			32.16			31.06			31.70		
Approach LOS	C			C			C			C		
d_I, Intersection Delay [s/veh]	31.02											
Intersection LOS	C											
Intersection V/C	0.756											

**Emissions**

Vehicle Miles Traveled [mph]	7.22	1.14	1.15	11.08	16.60	71.61	69.11	6.13	90.05
Stops [stops/h]	221.84	19.41	28.19	259.48	67.21	221.59	285.44	26.44	367.85
Fuel consumption [US gal/h]	3.21	0.26	0.44	3.81	1.63	5.63	6.76	0.62	8.45
CO [g/h]	224.26	18.37	30.64	266.15	113.68	393.82	472.67	43.27	590.96
NOx [g/h]	43.63	3.57	5.96	51.78	22.12	76.62	91.96	8.42	114.98
VOC [g/h]	51.98	4.26	7.10	61.68	26.35	91.27	109.55	10.03	136.96

**Other Modes**

g_Walk,mi, Effective Walk Time [s]	8.0	8.0	8.0	8.0
M_corner, Corner Circulation Area [ft <sup>2</sup> /ped]	0.00	0.00	0.00	0.00
M_CW, Crosswalk Circulation Area [ft <sup>2</sup> /ped]	0.00	0.00	0.00	0.00
d_p, Pedestrian Delay [s]	28.69	28.69	28.69	28.69
I_p,int, Pedestrian LOS Score for Intersectio	2.149	2.074	2.525	2.196
Crosswalk LOS	B	B	B	B
s_b, Saturation Flow Rate of the bicycle lane	2000	2000	2000	2000
c_b, Capacity of the bicycle lane [bicycles/h]	828	552	690	690
d_b, Bicycle Delay [s]	12.47	19.01	15.65	15.56
I_b,int, Bicycle LOS Score for Intersection	2.066	2.102	2.701	2.310
Bicycle LOS	B	B	B	B

**Sequence**

Ring 1	1	2	3	4	-	-	-	-	-	-	-	-	-	-	-
Ring 2	5	6	7	8	-	-	-	-	-	-	-	-	-	-	-
Ring 3	-	-	-	-	-	-	-	-	-	-	-	-	-	-	-
Ring 4	-	-	-	-	-	-	-	-	-	-	-	-	-	-	-

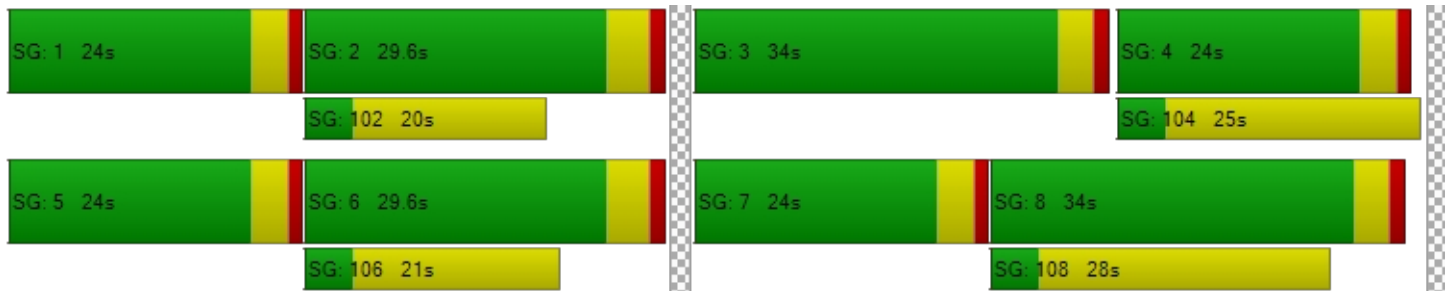

**Intersection Level Of Service Report**

**Intersection 15: Central Parkway & Panorama Drive/Pino Grande Road**

Control Type:	All-way stop	Delay (sec / veh):	11.0
Analysis Method:	HCM 7th Edition	Level Of Service:	B
Analysis Period:	15 minutes	Volume to Capacity (v/c):	0.359

**Intersection Setup**

Name	Pino Grande Road			Panorama Drive			Central Parkway			Central Parkway		
Approach	Northbound			Southbound			Eastbound			Westbound		
Lane Configuration	+			+r			+r			+r		
Turning Movement	Left	Thru	Right	Left	Thru	Right	Left	Thru	Right	Left	Thru	Right
Lane Width [ft]	12.00	12.00	12.00	12.00	12.00	12.00	12.00	12.00	12.00	12.00	12.00	12.00
No. of Lanes in Entry Pocket	0	0	0	0	0	1	1	0	0	1	0	0
Entry Pocket Length [ft]	100.00	100.00	100.00	100.00	100.00	100.00	275.00	100.00	100.00	100.00	100.00	100.00
No. of Lanes in Exit Pocket	0	0	0	0	0	0	0	0	0	0	0	0
Exit Pocket Length [ft]	0.00	0.00	0.00	0.00	0.00	0.00	0.00	0.00	0.00	0.00	0.00	0.00
Speed [mph]	30.00			30.00			30.00			30.00		
Grade [%]	0.00			0.00			0.00			0.00		
Crosswalk	Yes			Yes			Yes			Yes		

**Volumes**

Name	Pino Grande Road			Panorama Drive			Central Parkway			Central Parkway		
Base Volume Input [veh/h]	37	2	0	1	4	127	97	84	6	0	91	2
Base Volume Adjustment Factor	1.0000	1.0000	1.0000	1.0000	1.0000	1.0000	1.0000	1.0000	1.0000	1.0000	1.0000	1.0000
Heavy Vehicles Percentage [%]	0.00	0.00	0.00	0.00	0.00	0.00	2.10	1.20	0.00	0.00	0.00	0.00
Growth Factor	1.0000	1.0000	1.0000	1.0000	1.0000	1.0000	1.0000	1.0000	1.0000	1.0000	1.0000	1.0000
In-Process Volume [veh/h]	0	0	0	0	0	0	0	0	0	0	0	0
Site-Generated Trips [veh/h]	0	0	0	0	0	0	0	0	0	0	0	0
Diverted Trips [veh/h]	0	0	0	0	0	0	0	0	0	0	0	0
Pass-by Trips [veh/h]	0	0	0	0	0	0	0	0	0	0	0	0
Existing Site Adjustment Volume [veh/h]	0	0	0	0	0	0	0	0	0	0	0	0
Other Volume [veh/h]	0	0	0	0	0	0	0	0	0	0	0	0
Total Hourly Volume [veh/h]	37	2	0	1	4	127	97	84	6	0	91	2
Peak Hour Factor	0.5300	0.5300	0.5300	0.5300	0.5300	0.5300	0.5300	0.5300	0.5300	0.5300	0.5300	0.5300
Other Adjustment Factor	1.0000	1.0000	1.0000	1.0000	1.0000	1.0000	1.0000	1.0000	1.0000	1.0000	1.0000	1.0000
Total 15-Minute Volume [veh/h]	17	1	0	0	2	60	46	40	3	0	43	1
Total Analysis Volume [veh/h]	70	4	0	2	8	240	183	158	11	0	172	4
Pedestrian Volume [ped/h]	117			1			103			89		



**Intersection Settings**

**Lanes**

Capacity per Entry Lane [veh/h]	549	581	669	578	636	608	610
Degree of Utilization, x	0.13	0.02	0.36	0.32	0.27	0.00	0.29

**Movement, Approach, & Intersection Results**

95th-Percentile Queue Length [veh]	0.46	0.05	1.63	1.35	1.07	0.00	1.19
95th-Percentile Queue Length [ft]	11.60	1.31	40.78	33.79	26.64	0.00	29.79
Approach Delay [s/veh]	10.58	10.99		11.11		10.99	
Approach LOS	B	B		B		B	
Intersection Delay [s/veh]	11.01						
Intersection LOS	B						



**Intersection Level Of Service Report**  
**Intersection 16: Airway Boulevard & N. Canyons Parkway**

Control Type:	Signalized	Delay (sec / veh):	13.7
Analysis Method:	HCM 7th Edition	Level Of Service:	B
Analysis Period:	15 minutes	Volume to Capacity (v/c):	0.271

**Intersection Setup**

Name	Airway Boulevard			Driveway			N. Canyons Parkway			N Canyons Parkway		
Approach	Northbound			Southbound			Eastbound			Westbound		
Lane Configuration	⇌⇌⇌			+			⇌⇌			⇌⇌⇌		
Turning Movement	Left	Thru	Right	Left	Thru	Right	Left	Thru	Right	Left	Thru	Right
Lane Width [ft]	12.00	12.00	12.00	12.00	12.00	12.00	12.00	12.00	12.00	12.00	12.00	12.00
No. of Lanes in Entry Pocket	0	0	0	0	0	0	0	0	0	1	0	1
Entry Pocket Length [ft]	100.00	100.00	100.00	100.00	100.00	100.00	100.00	100.00	100.00	110.00	100.00	195.00
No. of Lanes in Exit Pocket	0	0	0	0	0	0	0	0	0	0	0	0
Exit Pocket Length [ft]	0.00	0.00	0.00	0.00	0.00	0.00	0.00	0.00	0.00	0.00	0.00	0.00
Speed [mph]	40.00			30.00			40.00			40.00		
Grade [%]	0.00			0.00			0.00			0.00		
Curb Present	Yes			Yes			Yes			Yes		
Crosswalk	Yes			Yes			Yes			No		





**Volumes**

Name	Airway Boulevard			Driveway			N. Canyons Parkway			N Canyons Parkway		
Base Volume Input [veh/h]	111	14	439	0	4	0	0	5	53	317	9	1
Base Volume Adjustment Factor	1.0000	1.0000	1.0000	1.0000	1.0000	1.0000	1.0000	1.0000	1.0000	1.0000	1.0000	1.0000
Heavy Vehicles Percentage [%]	3.60	0.00	2.10	0.00	0.00	0.00	2.00	0.00	22.60	4.40	0.00	0.00
Proportion of CAVs [%]	0.00											
Growth Factor	1.0000	1.0000	1.0000	1.0000	1.0000	1.0000	1.0000	1.0000	1.0000	1.0000	1.0000	1.0000
In-Process Volume [veh/h]	0	0	0	0	0	0	0	0	0	0	0	0
Site-Generated Trips [veh/h]	0	0	0	0	0	0	0	0	0	0	0	0
Diverted Trips [veh/h]	0	0	0	0	0	0	0	0	0	0	0	0
Pass-by Trips [veh/h]	0	0	0	0	0	0	0	0	0	0	0	0
Existing Site Adjustment Volume [veh/h]	0	0	0	0	0	0	0	0	0	0	0	0
Other Volume [veh/h]	0	0	0	0	0	0	0	0	0	0	0	0
Right Turn on Red Volume [veh/h]	0	0	0	0	0	0	0	0	0	0	0	0
Total Hourly Volume [veh/h]	111	14	439	0	4	0	0	5	53	317	9	1
Peak Hour Factor	0.8900	0.8900	0.8900	0.8900	0.8900	0.8900	1.0000	0.8900	0.8900	0.8900	0.8900	0.8900
Other Adjustment Factor	1.0000	1.0000	1.0000	1.0000	1.0000	1.0000	1.0000	1.0000	1.0000	1.0000	1.0000	1.0000
Total 15-Minute Volume [veh/h]	31	4	123	0	1	0	0	1	15	89	3	0
Total Analysis Volume [veh/h]	125	16	493	0	4	0	0	6	60	356	10	1
Presence of On-Street Parking	No		No	No		No	No		No	No		No
On-Street Parking Maneuver Rate [/h]	0	0	0	0	0	0	0	0	0	0	0	0
Local Bus Stopping Rate [/h]	0	0	0	0	0	0	0	0	0	0	0	0
v_do, Outbound Pedestrian Volume crossing	0			0			0			0		
v_di, Inbound Pedestrian Volume crossing m	0			0			0			0		
v_co, Outbound Pedestrian Volume crossing	0			1			0			0		
v_ci, Inbound Pedestrian Volume crossing mi	0			0			0			1		
v_ab, Corner Pedestrian Volume [ped/h]	0			0			0			0		
Bicycle Volume [bicycles/h]	0			0			0			0		



**Intersection Settings**

Located in CBD	No
Signal Coordination Group	-
Cycle Length [s]	105
Active Pattern	Pattern 1
Coordination Type	Time of Day Pattern Coordinated
Actuation Type	Fully actuated
Offset [s]	0.0
Offset Reference	Lead Green - Beginning of First Green
Permissive Mode	SingleBand
Lost time [s]	12.00

**Phasing & Timing (Basic)**

Control Type	Split	Split	Overlap	Split	Split	Split	Permiss	Permiss	Permiss	Protecte	Permiss	Permiss
Signal Group	0	8	8	0	4	0	0	2	0	1	6	0
Auxiliary Signal Groups			1,8									
Maximum Green [s]	0	20	20	0	12	0	0	15	0	50	50	0
Amber [s]	0.0	3.2	3.2	0.0	3.0	0.0	0.0	5.0	0.0	5.0	5.0	0.0
All red [s]	0.0	1.0	1.0	0.0	1.0	0.0	0.0	1.0	0.0	1.0	1.0	0.0
Walk [s]	0	0	0	0	5	0	0	5	0	0	5	0
Pedestrian Clearance [s]	0	0	0	0	28	0	0	29	0	0	12	0
Delayed Vehicle Green [s]	0.0	0.0	0.0	0.0	0.0	0.0	0.0	0.0	0.0	0.0	0.0	0.0
Rest In Walk		No			No			No			No	
I1, Start-Up Lost Time [s]	0.0	2.0	2.0	0.0	2.0	0.0	0.0	2.0	0.0	2.0	2.0	0.0
I2, Clearance Lost Time [s]	0.0	2.0	2.0	0.0	2.0	0.0	0.0	2.0	0.0	2.0	2.0	0.0
Detector Location [ft]	0.0	0.0	0.0	0.0	0.0	0.0	0.0	0.0	0.0	0.0	0.0	0.0
Detector Length [ft]	0.0	20.0	20.0	0.0	20.0	0.0	0.0	20.0	0.0	20.0	20.0	0.0
I, Upstream Filtering Factor	1.00	1.00	1.00	1.00	1.00	1.00	1.00	1.00	1.00	1.00	1.00	1.00

**Phasing & Timing: Pattern 1**

Split [s]	0	25	25	0	20	0	0	30	0	30	60	0
Lead / Lag	-	-	-	-	-	-	-	-	-	Lead	-	-
Minimum Green [s]	0	4	4	0	3	0	0	10	0	3	7	0
Vehicle Extension [s]	0.0	2.0	2.0	0.0	2.0	0.0	0.0	2.0	0.0	2.0	2.0	0.0
Minimum Recall		No	No		No			No		No	Yes	
Maximum Recall		No	No		No			No		Yes	Yes	
Pedestrian Recall		No	No		No			No		No	No	

**Exclusive Pedestrian Phase**

Pedestrian Signal Group	0
Pedestrian Walk [s]	0
Pedestrian Clearance [s]	0



**Lane Group Calculations**

Lane Group	C	R	C	C	R	L	C	R
C, Cycle Length [s]	105	105	105	105	105	105	105	105
L, Total Lost Time per Cycle [s]	4.00	4.00	4.00	4.00	4.00	4.00	4.00	4.00
l1_p, Permitted Start-Up Lost Time [s]	0.00	0.00	0.00	0.00	0.00	0.00	0.00	0.00
l2, Clearance Lost Time [s]	2.00	0.00	2.00	2.00	2.00	2.00	2.00	2.00
g_i, Effective Green Time [s]	11	82	0	11	11	67	82	82
g / C, Green / Cycle	0.11	0.78	0.00	0.10	0.10	0.64	0.78	0.78
(v / s)_i Volume / Saturation Flow Rate	0.08	0.18	0.00	0.00	0.05	0.10	0.01	0.00
s, saturation flow rate [veh/h]	1819	2811	1900	3618	1327	3392	1900	1614
c, Capacity [veh/h]	193	2143	7	364	134	2162	1475	1253
d1, Uniform Delay [s]	45.49	3.59	52.26	42.55	44.49	7.72	2.65	2.64
k, delay calibration	0.04	0.50	0.04	0.04	0.04	0.50	0.50	0.50
l, Upstream Filtering Factor	1.00	1.00	1.00	1.00	1.00	1.00	1.00	1.00
d2, Incremental Delay [s]	1.99	0.25	26.31	0.01	0.88	0.16	0.01	0.00
d3, Initial Queue Delay [s]	0.00	0.00	0.00	0.00	0.00	0.00	0.00	0.00
Rp, platoon ratio	1.00	1.00	1.00	1.00	1.00	1.00	1.00	1.00
PF, progression factor	1.00	1.00	1.00	1.00	1.00	1.00	1.00	1.00

**Lane Group Results**

X, volume / capacity	0.73	0.23	0.59	0.02	0.45	0.16	0.01	0.00
d, Delay for Lane Group [s/veh]	47.49	3.84	78.56	42.56	45.37	7.88	2.66	2.64
Lane Group LOS	D	A	E	D	D	A	A	A
Critical Lane Group	Yes	Yes	Yes	No	Yes	No	No	No
50th-Percentile Queue Length [veh/ln]	3.58	1.15	0.15	0.07	1.47	1.49	0.04	0.00
50th-Percentile Queue Length [ft/ln]	89.59	28.64	3.87	1.73	36.80	37.16	0.89	0.09
95th-Percentile Queue Length [veh/ln]	6.45	2.06	0.28	0.12	2.65	2.68	0.06	0.01
95th-Percentile Queue Length [ft/ln]	161.27	51.55	6.97	3.11	66.23	66.89	1.59	0.16

**Movement, Approach, & Intersection Results**

d_M, Delay for Movement [s/veh]	47.49	47.49	3.84	78.56	78.56	78.56	0.00	42.56	45.37	7.88	2.66	2.64
Movement LOS	D	D	A	E	E	E		D	D	A	A	A
d_A, Approach Delay [s/veh]	13.55			78.56				45.11		7.73		
Approach LOS	B			E				D		A		
d_I, Intersection Delay [s/veh]	13.74											
Intersection LOS	B											
Intersection V/C	0.271											

**Emissions**

Vehicle Miles Traveled [mph]	16.74	58.54	0.14	0.39	3.91	29.12	0.82	0.08
Stops [stops/h]	122.84	78.54	5.31	4.74	50.45	101.90	1.21	0.12
Fuel consumption [US gal/h]	3.17	3.25	0.10	0.11	1.19	2.62	0.05	0.00
CO [g/h]	221.51	227.47	6.92	7.87	83.16	182.80	3.26	0.33
NOx [g/h]	43.10	44.26	1.35	1.53	16.18	35.57	0.63	0.06
VOC [g/h]	51.34	52.72	1.60	1.82	19.27	42.37	0.76	0.08

**Other Modes**

g_Walk,mi, Effective Walk Time [s]	9.0	9.0	9.0	0.0
M_corner, Corner Circulation Area [ft <sup>2</sup> /ped]	0.00	0.00	0.00	0.00
M_CW, Crosswalk Circulation Area [ft <sup>2</sup> /ped]	0.00	5853.56	0.00	0.00
d_p, Pedestrian Delay [s]	43.90	43.90	43.90	0.00
I_p,int, Pedestrian LOS Score for Intersectio	2.690	1.734	2.361	0.000
Crosswalk LOS	B	A	B	F
s_b, Saturation Flow Rate of the bicycle lane	2000	2000	2000	2000
c_b, Capacity of the bicycle lane [bicycles/h]	396	305	457	1028
d_b, Bicycle Delay [s]	33.77	37.73	31.25	12.39
I_b,int, Bicycle LOS Score for Intersection	2.606	1.566	1.614	2.165
Bicycle LOS	B	A	A	B

**Sequence**

Ring 1	1	2	4	8	-	-	-	-	-	-	-	-	-	-	-
Ring 2	-	6	-	-	-	-	-	-	-	-	-	-	-	-	-
Ring 3	-	-	-	-	-	-	-	-	-	-	-	-	-	-	-
Ring 4	-	-	-	-	-	-	-	-	-	-	-	-	-	-	-



**Intersection Level Of Service Report**  
**Intersection 17: Airway Boulevard & I-580 WB Ramps**

Control Type:	Signalized	Delay (sec / veh):	9.8
Analysis Method:	HCM 7th Edition	Level Of Service:	A
Analysis Period:	15 minutes	Volume to Capacity (v/c):	0.223

**Intersection Setup**

Name	Airway Boulevard			Airway Boulevard			I-580 WB On-Ramp			I-580 WB Off-Ramp		
Approach	Northbound			Southbound			Eastbound			Westbound		
Lane Configuration	r			r						r rr		
Turning Movement	Left	Thru	Right	Left	Thru	Right	Left	Thru	Right	Left	Thru	Right
Lane Width [ft]	12.00	12.00	12.00	12.00	12.00	12.00	12.00	12.00	12.00	12.00	12.00	12.00
No. of Lanes in Entry Pocket	0	0	0	0	0	1	0	0	0	1	0	1
Entry Pocket Length [ft]	100.00	100.00	100.00	100.00	100.00	250.00	100.00	100.00	100.00	150.00	100.00	490.00
No. of Lanes in Exit Pocket	0	0	0	0	0	0	0	0	0	0	0	0
Exit Pocket Length [ft]	0.00	0.00	0.00	0.00	0.00	0.00	0.00	0.00	0.00	0.00	0.00	0.00
Speed [mph]	40.00			40.00			30.00			45.00		
Grade [%]	0.00			0.00			0.00			0.00		
Curb Present	Yes			Yes						Yes		
Crosswalk	No			No			No			Yes		



**Volumes**

Name	Airway Boulevard			Airway Boulevard			I-580 WB On-Ramp			I-580 WB Off-Ramp		
	Base Volume Input [veh/h]	0	613	131	0	158	278	0	0	0	48	0
Base Volume Adjustment Factor	1.0000	1.0000	1.0000	1.0000	1.0000	1.0000	1.0000	1.0000	1.0000	1.0000	1.0000	1.0000
Heavy Vehicles Percentage [%]	2.00	2.90	9.20	2.00	5.70	6.80	2.00	2.00	2.00	4.20	0.00	8.50
Proportion of CAVs [%]	0.00											
Growth Factor	1.0000	1.0000	1.0000	1.0000	1.0000	1.0000	1.0000	1.0000	1.0000	1.0000	1.0000	1.0000
In-Process Volume [veh/h]	0	0	0	0	0	0	0	0	0	0	0	0
Site-Generated Trips [veh/h]	0	0	0	0	0	0	0	0	0	0	0	0
Diverted Trips [veh/h]	0	0	0	0	0	0	0	0	0	0	0	0
Pass-by Trips [veh/h]	0	0	0	0	0	0	0	0	0	0	0	0
Existing Site Adjustment Volume [veh/h]	0	0	0	0	0	0	0	0	0	0	0	0
Other Volume [veh/h]	0	0	0	0	0	0	0	0	0	0	0	0
Right Turn on Red Volume [veh/h]	0	0	0	0	0	0	0	0	0	0	0	0
Total Hourly Volume [veh/h]	0	613	131	0	158	278	0	0	0	48	0	130
Peak Hour Factor	1.0000	0.8700	0.8700	1.0000	0.8700	0.8700	1.0000	1.0000	1.0000	0.8700	0.8700	0.8700
Other Adjustment Factor	1.0000	1.0000	1.0000	1.0000	1.0000	1.0000	1.0000	1.0000	1.0000	1.0000	1.0000	1.0000
Total 15-Minute Volume [veh/h]	0	176	38	0	45	80	0	0	0	14	0	37
Total Analysis Volume [veh/h]	0	705	151	0	182	320	0	0	0	55	0	149
Presence of On-Street Parking	No		No	No		No				No		No
On-Street Parking Maneuver Rate [/h]	0	0	0	0	0	0	0	0	0	0	0	0
Local Bus Stopping Rate [/h]	0	0	0	0	0	0	0	0	0	0	0	0
v_do, Outbound Pedestrian Volume crossing	0			0			0			0		
v_di, Inbound Pedestrian Volume crossing m	0			0			0			0		
v_co, Outbound Pedestrian Volume crossing	1			0			0			1		
v_ci, Inbound Pedestrian Volume crossing mi	1			0			0			1		
v_ab, Corner Pedestrian Volume [ped/h]	0			0			0			0		
Bicycle Volume [bicycles/h]	0			0			0			0		



**Intersection Settings**

Located in CBD	No
Signal Coordination Group	-
Cycle Length [s]	105
Active Pattern	Pattern 1
Coordination Type	Time of Day Pattern Coordinated
Actuation Type	Fully actuated
Offset [s]	91.0
Offset Reference	Lead Green - Beginning of First Green
Permissive Mode	SingleBand
Lost time [s]	9.00

**Phasing & Timing (Basic)**

Control Type	Permiss	Permiss	Unsigna	Permiss	Permiss	Unsigna	Permiss	Permiss	Permiss	Permiss	Permiss	Overlap
Signal Group	0	2	0	0	6	0	0	0	0	0	8	1
Auxiliary Signal Groups												1,8
Maximum Green [s]	0	30	0	0	25	0	0	0	0	0	20	12
Amber [s]	0.0	4.3	0.0	0.0	4.3	0.0	0.0	0.0	0.0	0.0	3.0	3.0
All red [s]	0.0	1.0	0.0	0.0	1.0	0.0	0.0	0.0	0.0	0.0	1.0	0.0
Walk [s]	0	7	0	0	0	0	0	0	0	0	0	0
Pedestrian Clearance [s]	0	15	0	0	0	0	0	0	0	0	0	0
Delayed Vehicle Green [s]	0.0	0.0	0.0	0.0	0.0	0.0	0.0	0.0	0.0	0.0	0.0	0.0
Rest In Walk		No			No						No	
I1, Start-Up Lost Time [s]	0.0	2.0	0.0	0.0	2.0	0.0	0.0	0.0	0.0	0.0	2.0	2.0
I2, Clearance Lost Time [s]	0.0	2.0	0.0	0.0	2.0	0.0	0.0	0.0	0.0	0.0	2.0	2.0
Detector Location [ft]	0.0	0.0	0.0	0.0	0.0	0.0	0.0	0.0	0.0	0.0	0.0	0.0
Detector Length [ft]	0.0	20.0	0.0	0.0	20.0	0.0	0.0	0.0	0.0	0.0	20.0	20.0
I, Upstream Filtering Factor	1.00	1.00	1.00	1.00	1.00	1.00	1.00	1.00	1.00	1.00	1.00	1.00

**Phasing & Timing: Pattern 1**

Split [s]	0	74	0	0	89	0	0	0	0	0	16	15
Lead / Lag	-	-	-	-	-	-	-	-	-	-	-	-
Minimum Green [s]	0	11	0	0	8	0	0	0	0	0	4	4
Vehicle Extension [s]	0.0	0.0	0.0	0.0	0.0	0.0	0.0	0.0	0.0	0.0	0.0	0.0
Minimum Recall		Yes			Yes						No	No
Maximum Recall		No			No						No	No
Pedestrian Recall		No			No						No	No

**Exclusive Pedestrian Phase**

Pedestrian Signal Group	0
Pedestrian Walk [s]	0
Pedestrian Clearance [s]	0



**Lane Group Calculations**

Lane Group	C	C		L	C	R
C, Cycle Length [s]	105	105		105	105	105
L, Total Lost Time per Cycle [s]	4.00	4.00		4.00	4.00	4.00
l1_p, Permitted Start-Up Lost Time [s]	0.00	0.00		0.00	0.00	0.00
l2, Clearance Lost Time [s]	2.00	2.00		2.00	2.00	0.00
g_i, Effective Green Time [s]	80	90		7	7	17
g / C, Green / Cycle	0.76	0.86		0.07	0.07	0.16
(v / s)_i Volume / Saturation Flow Rate	0.20	0.04		0.02	0.02	0.06
s, saturation flow rate [veh/h]	3535	4943		1749	1810	2667
c, Capacity [veh/h]	2688	4230		119	123	461
d1, Uniform Delay [s]	3.76	1.13		46.29	46.27	38.01
k, delay calibration	0.50	0.50		0.04	0.04	0.04
l, Upstream Filtering Factor	1.00	1.00		1.00	1.00	1.00
d2, Incremental Delay [s]	0.24	0.02		0.37	0.34	0.15
d3, Initial Queue Delay [s]	0.00	0.00		0.00	0.00	0.00
Rp, platoon ratio	1.00	1.00		1.00	1.00	1.00
PF, progression factor	1.00	1.00		1.00	1.00	1.00

**Lane Group Results**

X, volume / capacity	0.26	0.04		0.23	0.22	0.32
d, Delay for Lane Group [s/veh]	4.00	1.15		46.66	46.61	38.16
Lane Group LOS	A	A		D	D	D
Critical Lane Group	Yes	No		No	No	Yes
50th-Percentile Queue Length [veh/ln]	1.69	0.06		0.67	0.67	1.63
50th-Percentile Queue Length [ft/ln]	42.36	1.54		16.79	16.77	40.77
95th-Percentile Queue Length [veh/ln]	3.05	0.11		1.21	1.21	2.94
95th-Percentile Queue Length [ft/ln]	76.24	2.78		30.22	30.19	73.39





**Movement, Approach, & Intersection Results**

d_M, Delay for Movement [s/veh]	0.00	4.00	0.00	0.00	1.15	0.00	0.00	0.00	0.00	0.00	46.63	46.61	38.16
Movement LOS		A			A						D	D	D
d_A, Approach Delay [s/veh]	3.37		0.45			0.00			40.44				
Approach LOS	A		A			A			D				
d_I, Intersection Delay [s/veh]	9.82												
Intersection LOS	A												
Intersection V/C	0.223												

**Emissions**

Vehicle Miles Traveled [mph]	58.81	21.61	2.70	2.70	14.65
Stops [stops/h]	116.24	6.35	23.04	23.01	111.89
Fuel consumption [US gal/h]	3.82	0.88	0.64	0.64	3.05
CO [g/h]	267.16	61.45	44.76	44.71	213.22
NOx [g/h]	51.98	11.96	8.71	8.70	41.49
VOC [g/h]	61.92	14.24	10.37	10.36	49.42

**Other Modes**

g_Walk,mi, Effective Walk Time [s]	0.0	0.0	0.0	11.0
M_corner, Corner Circulation Area [ft <sup>2</sup> /ped]	0.00	0.00	0.00	0.00
M_CW, Crosswalk Circulation Area [ft <sup>2</sup> /ped]	0.00	0.00	0.00	0.00
d_p, Pedestrian Delay [s]	0.00	0.00	0.00	42.05
I_p,int, Pedestrian LOS Score for Intersectio	0.000	0.000	0.000	2.367
Crosswalk LOS	F	F	F	B
s_b, Saturation Flow Rate of the bicycle lane	2000	2000	2000	2000
c_b, Capacity of the bicycle lane [bicycles/h]	1309	1595	0	229
d_b, Bicycle Delay [s]	6.26	2.15	52.47	41.16
I_b,int, Bicycle LOS Score for Intersection	2.141	1.660	4.132	1.896
Bicycle LOS	B	A	D	A

**Sequence**

Ring 1	1	2	-	-	-	-	-	-	-	-	-	-	-	-	-	-
Ring 2	-	6	-	8	-	-	-	-	-	-	-	-	-	-	-	-
Ring 3	-	-	-	-	-	-	-	-	-	-	-	-	-	-	-	-
Ring 4	-	-	-	-	-	-	-	-	-	-	-	-	-	-	-	-



Vistro File: H:\...\PacVest\_20240229.vistro

Scenario 2 Existing PM

Report File: H:\...\ExistingPM\_LOS.pdf

3/1/2024

**Intersection Analysis Summary**

ID	Intersection Name	Control Type	Method	Worst Mvmt	V/C	Delay (s/veh)	LOS
1	Hacienda Drive & Dublin Boulevard	Signalized	HCM 7th Edition	SB Left	0.397	38.7	D
2	Tassajara Road & Central Parkway	Signalized	HCM 7th Edition	SB Left	0.475	27.9	C
3	Tassajara Road & Dublin Boulevard	Signalized	HCM 7th Edition	NB Right	0.665	37.0	D
4	Tassajara Road & I-580 WB Ramps	Signalized	HCM 7th Edition	WB Left	0.627	11.1	B
5	Santa Rita Rd & I-580 EB Ramps/Pimlico Dr	Signalized	HCM 7th Edition	SB Left	0.810	33.2	C
6	Tassajara Road & Fallon Road	Signalized	HCM 7th Edition	WB Left	0.394	15.2	B
7	Fallon Road & Positano Parkway	Signalized	HCM 7th Edition	SB Left	0.500	9.3	A
8	Fallon Road & Central Parkway	Signalized	HCM 7th Edition	SB Left	0.359	20.9	C
9	Fallon Road & Dublin Boulevard	Signalized	HCM 7th Edition	EB Left	0.484	21.4	C
10	Fallon Road & Fallon Gateway	Signalized	HCM 7th Edition	NB Left	0.589	13.0	B
11	Fallon Road & I-580 WB Ramps	Signalized	HCM 7th Edition	NB Thru	0.535	17.1	B
12	El Charro Road & I-580 EB Ramps	Signalized	HCM 7th Edition	EB Right	0.544	6.9	A
13	El Charro Road & Jack London Boulevard	Signalized	HCM 7th Edition	NB Right	0.691	11.3	B
14	Central Parkway & Sunset View Drive	Signalized	HCM 7th Edition	SB Left	0.259	11.1	B
15	Central Parkway & Panorama Drive/Pino Grande Road	All-way stop	HCM 7th Edition	EB Left	0.146	8.0	A
16	Airway Boulevard & N. Canyons Parkway	Signalized	HCM 7th Edition	SB Thru	0.455	16.4	B
17	Airway Boulevard & I-580 WB Ramps	Signalized	HCM 7th Edition	WB Left	0.214	10.1	B



V/C, Delay, LOS: For two-way stop, these values are taken from the movement with the worst (highest) delay value. For all other control types, they are taken for the whole intersection.



**Intersection Level Of Service Report**  
**Intersection 1: Hacienda Drive & Dublin Boulevard**

Control Type:	Signalized	Delay (sec / veh):	38.7
Analysis Method:	HCM 7th Edition	Level Of Service:	D
Analysis Period:	15 minutes	Volume to Capacity (v/c):	0.397

**Intersection Setup**

Name	Hacienda Drive			Hacienda Drive			Dublin Boulevard			Dublin Boulevard		
Approach	Northbound			Southbound			Eastbound			Westbound		
Lane Configuration	[Diagram]			[Diagram]			[Diagram]			[Diagram]		
Turning Movement	Left	Thru	Right	Left	Thru	Right	Left	Thru	Right	Left	Thru	Right
Lane Width [ft]	12.00	12.00	12.00	12.00	12.00	12.00	12.00	12.00	12.00	12.00	12.00	12.00
No. of Lanes in Entry Pocket	2	0	2	2	0	1	2	0	2	2	0	0
Entry Pocket Length [ft]	250.00	100.00	380.00	300.00	100.00	220.00	300.00	100.00	250.00	275.00	100.00	100.00
No. of Lanes in Exit Pocket	0	0	0	0	0	0	0	0	0	0	0	1
Exit Pocket Length [ft]	0.00	0.00	0.00	0.00	0.00	0.00	0.00	0.00	0.00	0.00	0.00	1000.00
Speed [mph]	35.00			35.00			40.00			40.00		
Grade [%]	0.00			0.00			0.00			0.00		
Curb Present	Yes			Yes			Yes			Yes		
Crosswalk	Yes			Yes			Yes			Yes		



**Volumes**

Name	Hacienda Drive			Hacienda Drive			Dublin Boulevard			Dublin Boulevard		
Base Volume Input [veh/h]	144	434	260	55	504	59	106	842	199	150	489	19
Base Volume Adjustment Factor	1.0000	1.0000	1.0000	1.0000	1.0000	1.0000	1.0000	1.0000	1.0000	1.0000	1.0000	1.0000
Heavy Vehicles Percentage [%]	0.00	0.20	0.80	0.00	0.20	5.10	1.90	1.10	1.50	1.30	1.60	0.00
Proportion of CAVs [%]	0.00											
Growth Factor	1.0000	1.0000	1.0000	1.0000	1.0000	1.0000	1.0000	1.0000	1.0000	1.0000	1.0000	1.0000
In-Process Volume [veh/h]	0	0	0	0	0	0	0	0	0	0	0	0
Site-Generated Trips [veh/h]	0	0	0	0	0	0	0	0	0	0	0	0
Diverted Trips [veh/h]	0	0	0	0	0	0	0	0	0	0	0	0
Pass-by Trips [veh/h]	0	0	0	0	0	0	0	0	0	0	0	0
Existing Site Adjustment Volume [veh/h]	0	0	0	0	0	0	0	0	0	0	0	0
Other Volume [veh/h]	0	0	0	0	0	0	0	0	0	0	0	0
Right Turn on Red Volume [veh/h]	0	0	0	0	0	0	0	0	0	0	0	0
Total Hourly Volume [veh/h]	144	434	260	55	504	59	106	842	199	150	489	19
Peak Hour Factor	0.9400	0.9400	0.9400	0.9400	0.9400	0.9400	0.9400	0.9400	0.9400	0.9400	0.9400	0.9400
Other Adjustment Factor	1.0000	1.0000	1.0000	1.0000	1.0000	1.0000	1.0000	1.0000	1.0000	1.0000	1.0000	1.0000
Total 15-Minute Volume [veh/h]	38	115	69	15	134	16	28	224	53	40	130	5
Total Analysis Volume [veh/h]	153	462	277	59	536	63	113	896	212	160	520	20
Presence of On-Street Parking	No		No	No		No	No		No	No		No
On-Street Parking Maneuver Rate [/h]	0	0	0	0	0	0	0	0	0	0	0	0
Local Bus Stopping Rate [/h]	0	0	0	0	0	0	0	0	0	0	0	0
v_do, Outbound Pedestrian Volume crossing	5			2			4			2		
v_di, Inbound Pedestrian Volume crossing m	4			2			5			2		
v_co, Outbound Pedestrian Volume crossing	6			1			2			7		
v_ci, Inbound Pedestrian Volume crossing mi	7			2			1			6		
v_ab, Corner Pedestrian Volume [ped/h]	0			0			0			0		
Bicycle Volume [bicycles/h]	1			0			4			1		



**Intersection Settings**

Located in CBD	No
Signal Coordination Group	-
Cycle Length [s]	150
Active Pattern	Pattern 1
Coordination Type	Time of Day Pattern Coordinated
Actuation Type	Fully actuated
Offset [s]	113.0
Offset Reference	Lead Green - Beginning of First Green
Permissive Mode	SingleBand
Lost time [s]	12.00

**Phasing & Timing (Basic)**

Control Type	Protecte	Permiss	Permiss	Protecte	Permiss	Permiss	Protecte	Permiss	Permiss	Protecte	Permiss	Permiss
Signal Group	3	8	0	7	4	0	5	2	0	1	6	0
Auxiliary Signal Groups												
Maximum Green [s]	20	50	0	20	50	0	20	60	0	20	60	0
Amber [s]	3.5	4.5	0.0	3.5	4.1	0.0	3.5	4.5	0.0	3.5	4.5	0.0
All red [s]	1.5	1.5	0.0	1.0	1.5	0.0	1.0	1.5	0.0	1.0	1.5	0.0
Walk [s]	0	4	0	0	4	0	0	4	0	0	4	0
Pedestrian Clearance [s]	0	32	0	0	40	0	0	43	0	0	35	0
Delayed Vehicle Green [s]	0.0	0.0	0.0	0.0	0.0	0.0	0.0	0.0	0.0	0.0	0.0	0.0
Rest In Walk		No			No			No			No	
I1, Start-Up Lost Time [s]	2.0	2.0	0.0	2.0	2.0	0.0	2.0	2.0	0.0	2.0	2.0	0.0
I2, Clearance Lost Time [s]	2.0	2.0	0.0	2.0	2.0	0.0	2.0	2.0	0.0	2.0	2.0	0.0
Detector Location [ft]	0.0	0.0	0.0	0.0	0.0	0.0	0.0	0.0	0.0	0.0	0.0	0.0
Detector Length [ft]	20.0	20.0	0.0	20.0	20.0	0.0	20.0	20.0	0.0	20.0	20.0	0.0
I, Upstream Filtering Factor	1.00	1.00	1.00	1.00	1.00	1.00	1.00	1.00	1.00	1.00	1.00	1.00

**Phasing & Timing: Pattern 1**

Split [s]	18	55	0	14	51	0	15	61	0	20	66	0
Lead / Lag	Lead	-	-	Lead	-	-	Lead	-	-	Lead	-	-
Minimum Green [s]	4	10	0	4	10	0	4	10	0	8	10	0
Vehicle Extension [s]	3.0	3.5	0.0	3.0	3.5	0.0	3.0	3.5	0.0	3.0	3.5	0.0
Minimum Recall	No	No		No	No		No	Yes		No	Yes	
Maximum Recall	No	No		No	No		No	No		No	No	
Pedestrian Recall	No	No		No	No		No	No		No	No	

**Exclusive Pedestrian Phase**

Pedestrian Signal Group	0
Pedestrian Walk [s]	0
Pedestrian Clearance [s]	0



**Lane Group Calculations**

Lane Group	L	C	R	L	C	R	L	C	R	L	C	C
C, Cycle Length [s]	150	150	150	150	150	150	150	150	150	150	150	150
L, Total Lost Time per Cycle [s]	4.00	4.00	4.00	4.00	4.00	4.00	4.00	4.00	4.00	4.00	4.00	4.00
l1_p, Permitted Start-Up Lost Time [s]	0.00	0.00	0.00	0.00	0.00	0.00	0.00	0.00	0.00	0.00	0.00	0.00
l2, Clearance Lost Time [s]	2.00	2.00	2.00	2.00	2.00	2.00	2.00	2.00	2.00	2.00	2.00	2.00
g_i, Effective Green Time [s]	8	28	28	5	25	25	7	92	92	10	94	94
g / C, Green / Cycle	0.05	0.19	0.19	0.03	0.17	0.17	0.05	0.61	0.61	0.06	0.63	0.63
(v / s)_i Volume / Saturation Flow Rate	0.03	0.13	0.10	0.02	0.10	0.04	0.03	0.17	0.08	0.05	0.10	0.10
s, saturation flow rate [veh/h]	5271	3612	2746	3514	5167	1542	3461	5131	2774	3478	3572	1837
c, Capacity [veh/h]	265	680	517	110	875	261	171	3130	1693	222	2230	1147
d1, Uniform Delay [s]	69.70	56.69	54.78	71.61	57.77	53.97	70.11	13.82	12.34	68.96	11.75	11.76
k, delay calibration	0.11	0.13	0.13	0.11	0.13	0.13	0.11	0.50	0.50	0.11	0.50	0.50
l, Upstream Filtering Factor	1.00	1.00	1.00	1.00	1.00	1.00	1.00	1.00	1.00	1.00	1.00	1.00
d2, Incremental Delay [s]	1.98	1.45	1.04	3.99	0.84	0.57	4.34	0.23	0.15	4.41	0.15	0.30
d3, Initial Queue Delay [s]	0.00	0.00	0.00	0.00	0.00	0.00	0.00	0.00	0.00	0.00	0.00	0.00
Rp, platoon ratio	1.00	1.00	1.00	1.00	1.00	1.00	1.00	1.00	1.00	1.00	1.00	1.00
PF, progression factor	1.00	1.00	1.00	1.00	1.00	1.00	1.00	1.00	1.00	1.00	1.00	1.00

**Lane Group Results**

X, volume / capacity	0.58	0.68	0.54	0.54	0.61	0.24	0.66	0.29	0.13	0.72	0.16	0.16
d, Delay for Lane Group [s/veh]	71.68	58.14	55.83	75.61	58.62	54.54	74.45	14.06	12.49	73.37	11.91	12.06
Lane Group LOS	E	E	E	E	E	D	E	B	B	E	B	B
Critical Lane Group	No	Yes	No	Yes	No	No	No	Yes	No	Yes	No	No
50th-Percentile Queue Length [veh/ln]	1.96	8.28	4.79	1.18	6.35	2.11	2.22	4.73	1.51	3.13	2.48	2.61
50th-Percentile Queue Length [ft/ln]	49.11	206.91	119.77	29.48	158.80	52.79	55.57	118.28	37.83	78.22	61.88	65.31
95th-Percentile Queue Length [veh/ln]	3.54	12.99	8.38	2.12	10.49	3.80	4.00	8.30	2.72	5.63	4.46	4.70
95th-Percentile Queue Length [ft/ln]	88.41	324.86	209.51	53.07	262.13	95.01	100.02	207.46	68.09	140.80	111.38	117.56



**Movement, Approach, & Intersection Results**

d_M, Delay for Movement [s/veh]	71.68	58.14	55.83	75.61	58.62	54.54	74.45	14.06	12.49	73.37	11.96	12.06
Movement LOS	E	E	E	E	E	D	E	B	B	E	B	B
d_A, Approach Delay [s/veh]	59.75			59.75			19.37			26.00		
Approach LOS	E			E			B			C		
d_I, Intersection Delay [s/veh]	38.74											
Intersection LOS	D											
Intersection V/C	0.397											

**Emissions**

Vehicle Miles Traveled [mph]	15.53	46.88	28.11	6.87	62.39	7.33	12.92	102.41	24.23	140.69	312.81	162.03
Stops [stops/h]	141.41	397.16	229.90	56.59	457.22	50.66	106.66	340.56	72.60	150.14	118.77	62.68
Fuel consumption [US gal/h]	3.89	10.24	5.95	1.60	12.21	1.36	3.22	9.58	2.12	8.90	13.23	6.87
CO [g/h]	271.69	715.75	415.70	111.49	853.44	95.04	225.24	669.41	148.19	622.33	925.04	480.35
NOx [g/h]	52.86	139.26	80.88	21.69	166.05	18.49	43.82	130.24	28.83	121.08	179.98	93.46
VOC [g/h]	62.97	165.88	96.34	25.84	197.79	22.03	52.20	155.14	34.34	144.23	214.39	111.33

**Other Modes**

g_Walk,mi, Effective Walk Time [s]	8.0			8.0			8.0			8.0		
M_corner, Corner Circulation Area [ft <sup>2</sup> /ped]	0.00			0.00			0.00			0.00		
M_CW, Crosswalk Circulation Area [ft <sup>2</sup> /ped]	355.69			1169.67			1473.17			161.35		
d_p, Pedestrian Delay [s]	67.23			67.23			67.23			67.23		
I_p,int, Pedestrian LOS Score for Intersectio	3.197			2.930			3.247			3.065		
Crosswalk LOS	C			C			C			C		
s_b, Saturation Flow Rate of the bicycle lane	2000			2000			2000			2000		
c_b, Capacity of the bicycle lane [bicycles/h]	653			605			733			800		
d_b, Bicycle Delay [s]	34.04			36.49			30.16			27.03		
I_b,int, Bicycle LOS Score for Intersection	2.296			1.922			2.231			1.945		
Bicycle LOS	B			A			B			A		

**Sequence**

Ring 1	1	2	3	4	-	-	-	-	-	-	-	-	-	-	-
Ring 2	5	6	7	8	-	-	-	-	-	-	-	-	-	-	-
Ring 3	-	-	-	-	-	-	-	-	-	-	-	-	-	-	-
Ring 4	-	-	-	-	-	-	-	-	-	-	-	-	-	-	-

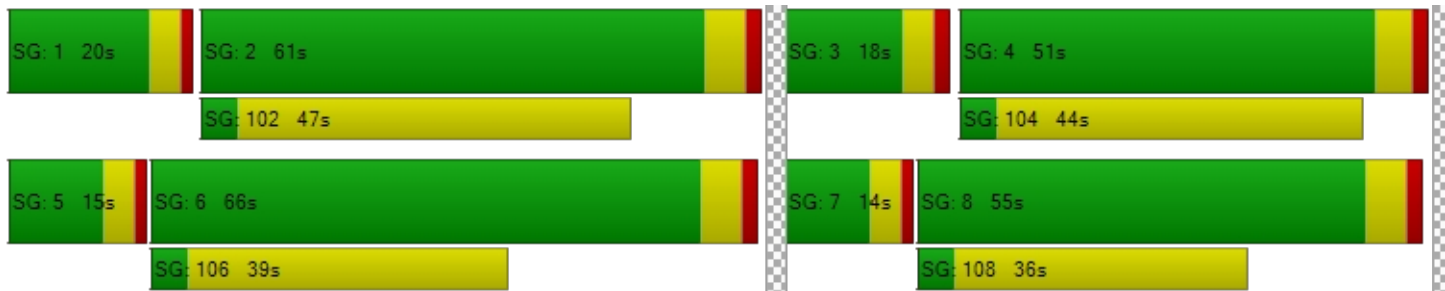



**Intersection Level Of Service Report**  
**Intersection 2: Tassajara Road & Central Parkway**

Control Type:	Signalized	Delay (sec / veh):	27.9
Analysis Method:	HCM 7th Edition	Level Of Service:	C
Analysis Period:	15 minutes	Volume to Capacity (v/c):	0.475

**Intersection Setup**

Name	Tassajara Road			Tassajara Road			Central Parkway			Central Parkway		
Approach	Northbound			Southbound			Eastbound			Westbound		
Lane Configuration	⇐   ⇐			⇐   ⇐			⇐  ⇐			⇐  ⇐		
Turning Movement	Left	Thru	Right	Left	Thru	Right	Left	Thru	Right	Left	Thru	Right
Lane Width [ft]	12.00	12.00	12.00	12.00	12.00	12.00	12.00	12.00	12.00	12.00	12.00	12.00
No. of Lanes in Entry Pocket	1	0	1	1	0	1	1	0	1	2	0	0
Entry Pocket Length [ft]	325.00	100.00	325.00	300.00	100.00	215.00	225.00	100.00	225.00	300.00	100.00	100.00
No. of Lanes in Exit Pocket	0	0	0	0	0	0	0	0	0	0	0	0
Exit Pocket Length [ft]	0.00	0.00	0.00	0.00	0.00	0.00	0.00	0.00	0.00	0.00	0.00	0.00
Speed [mph]	40.00			40.00			35.00			35.00		
Grade [%]	0.00			0.00			0.00			0.00		
Curb Present	Yes			Yes			Yes			Yes		
Crosswalk	Yes			Yes			Yes			Yes		



**Volumes**

Name	Tassajara Road			Tassajara Road			Central Parkway			Central Parkway		
Base Volume Input [veh/h]	68	912	174	19	824	42	69	140	97	153	101	23
Base Volume Adjustment Factor	1.0000	1.0000	1.0000	1.0000	1.0000	1.0000	1.0000	1.0000	1.0000	1.0000	1.0000	1.0000
Heavy Vehicles Percentage [%]	0.00	0.10	0.00	0.00	0.60	0.00	0.00	0.00	0.00	0.00	0.00	0.00
Proportion of CAVs [%]	0.00											
Growth Factor	1.0000	1.0000	1.0000	1.0000	1.0000	1.0000	1.0000	1.0000	1.0000	1.0000	1.0000	1.0000
In-Process Volume [veh/h]	0	0	0	0	0	0	0	0	0	0	0	0
Site-Generated Trips [veh/h]	0	0	0	0	0	0	0	0	0	0	0	0
Diverted Trips [veh/h]	0	0	0	0	0	0	0	0	0	0	0	0
Pass-by Trips [veh/h]	0	0	0	0	0	0	0	0	0	0	0	0
Existing Site Adjustment Volume [veh/h]	0	0	0	0	0	0	0	0	0	0	0	0
Other Volume [veh/h]	0	0	0	0	0	0	0	0	0	0	0	0
Right Turn on Red Volume [veh/h]	0	0	0	0	0	0	0	0	0	0	0	0
Total Hourly Volume [veh/h]	68	912	174	19	824	42	69	140	97	153	101	23
Peak Hour Factor	0.8900	0.8900	0.8900	0.8900	0.8900	0.8900	0.8900	0.8900	0.8900	0.8900	0.8900	0.8900
Other Adjustment Factor	1.0000	1.0000	1.0000	1.0000	1.0000	1.0000	1.0000	1.0000	1.0000	1.0000	1.0000	1.0000
Total 15-Minute Volume [veh/h]	19	256	49	5	231	12	19	39	27	43	28	6
Total Analysis Volume [veh/h]	76	1025	196	21	926	47	78	157	109	172	113	26
Presence of On-Street Parking	No		No	No		No	No		No	No		No
On-Street Parking Maneuver Rate [/h]	0	0	0	0	0	0	0	0	0	0	0	0
Local Bus Stopping Rate [/h]	0	0	0	0	0	0	0	0	0	0	0	0
v_do, Outbound Pedestrian Volume crossing	2			1			2			0		
v_di, Inbound Pedestrian Volume crossing m	2			0			2			1		
v_co, Outbound Pedestrian Volume crossing	0			4			5			0		
v_ci, Inbound Pedestrian Volume crossing mi	0			5			4			0		
v_ab, Corner Pedestrian Volume [ped/h]	0			0			0			0		
Bicycle Volume [bicycles/h]	1			1			0			0		



**Intersection Settings**

Located in CBD	No
Signal Coordination Group	-
Cycle Length [s]	130
Active Pattern	Pattern 1
Coordination Type	Time of Day Pattern Coordinated
Actuation Type	Fully actuated
Offset [s]	124.0
Offset Reference	Lead Green - Beginning of First Green
Permissive Mode	SingleBand
Lost time [s]	12.00

**Phasing & Timing (Basic)**

Control Type	Protecte	Permiss	Permiss	Protecte	Permiss	Permiss	Protecte	Permiss	Permiss	Protecte	Permiss	Permiss
Signal Group	3	8	0	7	4	0	5	2	0	1	6	0
Auxiliary Signal Groups												
Maximum Green [s]	20	40	0	20	40	0	20	20	0	20	20	0
Amber [s]	3.5	4.3	0.0	3.5	4.3	0.0	3.5	4.1	0.0	3.5	4.1	0.0
All red [s]	1.0	1.0	0.0	1.0	1.0	0.0	1.0	1.0	0.0	1.0	1.0	0.0
Walk [s]	0	4	0	0	4	0	0	4	0	0	4	0
Pedestrian Clearance [s]	0	20	0	0	24	0	0	36	0	0	30	0
Delayed Vehicle Green [s]	0.0	0.0	0.0	0.0	0.0	0.0	0.0	0.0	0.0	0.0	0.0	0.0
Rest In Walk		No			No			No			No	
I1, Start-Up Lost Time [s]	2.0	2.0	0.0	2.0	2.0	0.0	2.0	2.0	0.0	2.0	2.0	0.0
I2, Clearance Lost Time [s]	2.5	3.3	0.0	2.5	3.3	0.0	2.5	3.1	0.0	2.5	3.1	0.0
Detector Location [ft]	0.0	0.0	0.0	0.0	0.0	0.0	0.0	0.0	0.0	0.0	0.0	0.0
Detector Length [ft]	20.0	20.0	0.0	20.0	20.0	0.0	20.0	20.0	0.0	20.0	20.0	0.0
I, Upstream Filtering Factor	1.00	1.00	1.00	1.00	1.00	1.00	1.00	1.00	1.00	1.00	1.00	1.00

**Phasing & Timing: Pattern 1**

Split [s]	18	48	0	18	48	0	18	45	0	19	46	0
Lead / Lag	Lead	-	-	Lead	-	-	Lead	-	-	Lead	-	-
Minimum Green [s]	13	12	0	13	12	0	13	13	0	14	13	0
Vehicle Extension [s]	2.5	4.0	0.0	2.5	4.0	0.0	2.5	2.5	0.0	2.5	2.5	0.0
Minimum Recall	No	Yes		No	Yes		No	No		No	No	
Maximum Recall	No	No		No	No		No	No		No	No	
Pedestrian Recall	No	No		No	No		No	No		No	No	

**Exclusive Pedestrian Phase**

Pedestrian Signal Group	0
Pedestrian Walk [s]	0
Pedestrian Clearance [s]	0



**Lane Group Calculations**

Lane Group	L	C	R	L	C	R	L	C	R	L	C
C, Cycle Length [s]	130	130	130	130	130	130	130	130	130	130	130
L, Total Lost Time per Cycle [s]	4.50	5.30	5.30	4.50	5.30	5.30	4.50	5.10	5.10	4.50	5.10
l1_p, Permitted Start-Up Lost Time [s]	0.00	0.00	0.00	0.00	0.00	0.00	0.00	0.00	0.00	0.00	0.00
l2, Clearance Lost Time [s]	2.50	3.30	3.30	2.50	3.30	3.30	2.50	3.10	3.10	2.50	3.10
g_i, Effective Green Time [s]	12	75	75	7	69	69	12	15	15	14	17
g / C, Green / Cycle	0.09	0.58	0.58	0.05	0.53	0.53	0.09	0.11	0.11	0.11	0.13
(v / s)_i Volume / Saturation Flow Rate	0.04	0.28	0.12	0.01	0.26	0.03	0.04	0.08	0.07	0.05	0.08
s, saturation flow rate [veh/h]	1810	3615	1582	1810	3600	1568	1810	1900	1598	3514	1838
c, Capacity [veh/h]	170	2077	909	97	1924	838	171	218	184	378	236
d1, Uniform Delay [s]	55.70	16.41	13.38	58.90	18.97	14.51	55.71	55.49	54.59	54.40	53.41
k, delay calibration	0.08	0.50	0.50	0.08	0.50	0.50	0.08	0.08	0.08	0.08	0.08
l, Upstream Filtering Factor	1.00	1.00	1.00	1.00	1.00	1.00	1.00	1.00	1.00	1.00	1.00
d2, Incremental Delay [s]	1.37	0.84	0.54	0.82	0.87	0.13	1.42	3.30	2.27	0.63	1.74
d3, Initial Queue Delay [s]	0.00	0.00	0.00	0.00	0.00	0.00	0.00	0.00	0.00	0.00	0.00
Rp, platoon ratio	1.00	1.00	1.00	1.00	1.00	1.00	1.00	1.00	1.00	1.00	1.00
PF, progression factor	1.00	1.00	1.00	1.00	1.00	1.00	1.00	1.00	1.00	1.00	1.00

**Lane Group Results**

X, volume / capacity	0.45	0.49	0.22	0.22	0.48	0.06	0.46	0.72	0.59	0.45	0.59
d, Delay for Lane Group [s/veh]	57.07	17.25	13.92	59.72	19.83	14.64	57.13	58.79	56.86	55.03	55.15
Lane Group LOS	E	B	B	E	B	B	E	E	E	E	E
Critical Lane Group	Yes	No	No	No	Yes	No	No	Yes	No	Yes	No
50th-Percentile Queue Length [veh/ln]	2.40	8.83	2.82	0.68	8.62	0.68	2.48	5.14	3.49	2.67	4.38
50th-Percentile Queue Length [ft/ln]	59.90	220.78	70.39	16.94	215.58	17.04	61.99	128.43	87.19	66.64	109.47
95th-Percentile Queue Length [veh/ln]	4.31	13.70	5.07	1.22	13.44	1.23	4.46	8.85	6.28	4.80	7.81
95th-Percentile Queue Length [ft/ln]	107.81	342.62	126.70	30.49	335.97	30.67	111.58	221.36	156.95	119.95	195.27



**Movement, Approach, & Intersection Results**

d_M, Delay for Movement [s/veh]	57.07	17.25	13.92	59.72	19.83	14.64	57.13	58.79	56.86	55.03	55.15	55.15
Movement LOS	E	B	B	E	B	B	E	E	E	E	E	E
d_A, Approach Delay [s/veh]	19.08			20.43			57.80			55.08		
Approach LOS	B			C			E			E		
d_I, Intersection Delay [s/veh]	27.86											
Intersection LOS	C											
Intersection V/C	0.475											

**Emissions**

Vehicle Miles Traveled [mph]	21.92	295.60	56.52	3.99	176.15	8.94	10.26	20.66	14.34	23.32	18.85
Stops [stops/h]	66.36	489.18	77.98	18.76	477.66	18.87	68.68	142.29	96.60	147.66	121.28
Fuel consumption [US gal/h]	2.32	18.99	3.35	0.58	14.74	0.65	1.81	3.74	2.53	3.93	3.19
CO [g/h]	162.13	1327.56	233.89	40.72	1030.30	45.13	126.83	261.12	177.14	274.40	223.00
NOx [g/h]	31.55	258.29	45.51	7.92	200.46	8.78	24.68	50.80	34.47	53.39	43.39
VOC [g/h]	37.58	307.67	54.21	9.44	238.78	10.46	29.39	60.52	41.05	63.59	51.68

**Other Modes**

g_Walk,mi, Effective Walk Time [s]	8.0		8.0		8.0		8.0	
M_corner, Corner Circulation Area [ft <sup>2</sup> /ped]	0.00		0.00		0.00		0.00	
M_CW, Crosswalk Circulation Area [ft <sup>2</sup> /ped]	1148.63		5331.48		497.74		0.00	
d_p, Pedestrian Delay [s]	57.24		57.24		57.24		57.24	
I_p,int, Pedestrian LOS Score for Intersectio	3.152		2.932		2.316		2.345	
Crosswalk LOS	C		C		B		B	
s_b, Saturation Flow Rate of the bicycle lane	2000		2000		2000		2000	
c_b, Capacity of the bicycle lane [bicycles/h]	657		657		614		629	
d_b, Bicycle Delay [s]	29.32		29.32		31.21		30.52	
I_b,int, Bicycle LOS Score for Intersection	2.630		2.380		2.127		2.073	
Bicycle LOS	B		B		B		B	

**Sequence**

Ring 1	1	2	3	4	-	-	-	-	-	-	-	-	-	-	-
Ring 2	5	6	7	8	-	-	-	-	-	-	-	-	-	-	-
Ring 3	-	-	-	-	-	-	-	-	-	-	-	-	-	-	-
Ring 4	-	-	-	-	-	-	-	-	-	-	-	-	-	-	-



**Intersection Level Of Service Report**  
**Intersection 3: Tassajara Road & Dublin Boulevard**

Control Type:	Signalized	Delay (sec / veh):	37.0
Analysis Method:	HCM 7th Edition	Level Of Service:	D
Analysis Period:	15 minutes	Volume to Capacity (v/c):	0.665

**Intersection Setup**

Name	Tassajara Road			Tassajara Road			Dublin Boulevard			Dublin Boulevard		
Approach	Northbound			Southbound			Eastbound			Westbound		
Lane Configuration	[Diagram]			[Diagram]			[Diagram]			[Diagram]		
Turning Movement	Left	Thru	Right	Left	Thru	Right	Left	Thru	Right	Left	Thru	Right
Lane Width [ft]	12.00	12.00	12.00	12.00	12.00	12.00	12.00	12.00	12.00	12.00	12.00	12.00
No. of Lanes in Entry Pocket	3	0	1	2	0	2	2	0	2	3	0	0
Entry Pocket Length [ft]	380.00	100.00	250.00	295.00	100.00	290.00	265.00	100.00	330.00	395.00	100.00	100.00
No. of Lanes in Exit Pocket	0	0	1	0	0	0	0	0	0	0	0	0
Exit Pocket Length [ft]	0.00	0.00	49.21	0.00	0.00	0.00	0.00	0.00	0.00	0.00	0.00	0.00
Speed [mph]	30.00			40.00			40.00			40.00		
Grade [%]	0.00			0.00			0.00			0.00		
Curb Present	Yes			Yes			Yes			Yes		
Crosswalk	Yes			Yes			Yes			Yes		



**Volumes**

Name	Tassajara Road			Tassajara Road			Dublin Boulevard			Dublin Boulevard		
	Base Volume Input [veh/h]	303	781	454	85	919	125	259	527	469	419	306
Base Volume Adjustment Factor	1.0000	1.0000	1.0000	1.0000	1.0000	1.0000	1.0000	1.0000	1.0000	1.0000	1.0000	1.0000
Heavy Vehicles Percentage [%]	0.70	0.00	0.00	1.20	0.40	0.00	0.40	0.80	13.00	0.20	1.30	0.00
Proportion of CAVs [%]	0.00											
Growth Factor	1.0000	1.0000	1.0000	1.0000	1.0000	1.0000	1.0000	1.0000	1.0000	1.0000	1.0000	1.0000
In-Process Volume [veh/h]	0	0	0	0	0	0	0	0	0	0	0	0
Site-Generated Trips [veh/h]	0	0	0	0	0	0	0	0	0	0	0	0
Diverted Trips [veh/h]	0	0	0	0	0	0	0	0	0	0	0	0
Pass-by Trips [veh/h]	0	0	0	0	0	0	0	0	0	0	0	0
Existing Site Adjustment Volume [veh/h]	0	0	0	0	0	0	0	0	0	0	0	0
Other Volume [veh/h]	0	0	0	0	0	0	0	0	0	0	0	0
Right Turn on Red Volume [veh/h]	0	0	0	0	0	0	0	0	0	0	0	0
Total Hourly Volume [veh/h]	303	781	454	85	919	125	259	527	469	419	306	44
Peak Hour Factor	0.9100	0.9100	0.9100	0.9100	0.9100	0.9100	0.9100	0.9100	0.9100	0.9100	0.9100	0.9100
Other Adjustment Factor	1.0000	1.0000	1.0000	1.0000	1.0000	1.0000	1.0000	1.0000	1.0000	1.0000	1.0000	1.0000
Total 15-Minute Volume [veh/h]	83	215	125	23	252	34	71	145	129	115	84	12
Total Analysis Volume [veh/h]	333	858	499	93	1010	137	285	579	515	460	336	48
Presence of On-Street Parking	No		No	No		No	No		No	No		No
On-Street Parking Maneuver Rate [/h]	0	0	0	0	0	0	0	0	0	0	0	0
Local Bus Stopping Rate [/h]	0	0	0	0	0	0	0	0	0	0	0	0
v_do, Outbound Pedestrian Volume crossing	0			2			3			0		
v_di, Inbound Pedestrian Volume crossing m	0			3			2			0		
v_co, Outbound Pedestrian Volume crossing	0			4			0			3		
v_ci, Inbound Pedestrian Volume crossing mi	0			3			0			4		
v_ab, Corner Pedestrian Volume [ped/h]	0			0			0			0		
Bicycle Volume [bicycles/h]	1			0			1			0		



**Intersection Settings**

Located in CBD	No
Signal Coordination Group	-
Cycle Length [s]	90
Active Pattern	Free Running (No Pattern)
Coordination Type	<i>Free Running</i>
Actuation Type	<i>Fully actuated</i>
Offset [s]	0.0
Offset Reference	Lead Green - Beginning of First Green
Permissive Mode	SingleBand
Lost time [s]	12.00

**Phasing & Timing (Basic)**

Control Type	Protecte	Permiss	Permiss	Protecte	Permiss	Permiss	Protecte	Permiss	Overlap	Protecte	Permiss	Permiss
Signal Group	3	8	0	7	4	0	5	2	2	1	6	0
Auxiliary Signal Groups									2,3			
Maximum Green [s]	20	35	0	20	35	0	20	35	35	20	35	0
Amber [s]	3.5	4.5	0.0	3.5	4.5	0.0	3.5	4.5	4.5	3.5	4.5	0.0
All red [s]	1.5	1.5	0.0	1.5	1.5	0.0	1.5	1.5	1.5	1.5	1.5	0.0
Walk [s]	0	4	0	0	4	0	0	0	0	0	4	0
Pedestrian Clearance [s]	0	29	0	0	42	0	0	0	0	0	42	0
Delayed Vehicle Green [s]	0.0	0.0	0.0	0.0	0.0	0.0	0.0	0.0	0.0	0.0	0.0	0.0
Rest In Walk		No			No			No			No	
I1, Start-Up Lost Time [s]	2.0	2.0	0.0	2.0	2.0	0.0	2.0	2.0	2.0	2.0	2.0	0.0
I2, Clearance Lost Time [s]	2.0	2.0	0.0	2.0	2.0	0.0	2.0	2.0	2.0	2.0	2.0	0.0
Detector Location [ft]	0.0	0.0	0.0	0.0	0.0	0.0	0.0	0.0	0.0	0.0	0.0	0.0
Detector Length [ft]	20.0	20.0	0.0	20.0	20.0	0.0	20.0	20.0	20.0	20.0	20.0	0.0
I, Upstream Filtering Factor	1.00	1.00	1.00	1.00	1.00	1.00	1.00	1.00	1.00	1.00	1.00	1.00

**Phasing & Timing: Free Running (No Pattern)**

Split [s]	0	0	0	0	0	0	0	0	0	0	0	0
Lead / Lag	Lead	-	-	Lead	-	-	Lead	-	-	Lead	-	-
Minimum Green [s]	16	15	0	15	15	0	16	16	16	16	15	0
Vehicle Extension [s]	2.0	4.0	0.0	2.0	4.0	0.0	2.0	3.0	3.0	2.0	3.0	0.0
Minimum Recall	No	Yes		No	Yes		No	No	No	No	No	
Maximum Recall	No	No		No	No		No	No	No	No	No	
Pedestrian Recall	No	No		No	No		No	No	No	No	No	

**Exclusive Pedestrian Phase**

Pedestrian Signal Group	0
Pedestrian Walk [s]	0
Pedestrian Clearance [s]	0





**Lane Group Calculations**

Lane Group	L	C	R	L	C	R	L	C	R	L	C	C
C, Cycle Length [s]	109	109	109	109	109	109	109	109	109	109	109	109
L, Total Lost Time per Cycle [s]	4.00	4.00	4.00	4.00	4.00	4.00	4.00	4.00	4.00	4.00	4.00	4.00
l1_p, Permitted Start-Up Lost Time [s]	0.00	0.00	0.00	0.00	0.00	0.00	0.00	0.00	0.00	0.00	0.00	0.00
l2, Clearance Lost Time [s]	2.00	2.00	2.00	2.00	2.00	2.00	2.00	2.00	0.00	2.00	2.00	2.00
g_i, Effective Green Time [s]	19	37	37	15	32	32	17	24	47	17	24	24
g / C, Green / Cycle	0.18	0.34	0.34	0.14	0.30	0.30	0.16	0.22	0.44	0.16	0.22	0.22
(v / s)_i Volume / Saturation Flow Rate	0.06	0.24	0.31	0.03	0.15	0.05	0.08	0.16	0.20	0.09	0.10	0.10
s, saturation flow rate [veh/h]	5242	3618	1595	3481	6879	2844	3503	3595	2547	5263	1880	1794
c, Capacity [veh/h]	939	1224	540	484	2052	848	547	790	1085	822	413	394
d1, Uniform Delay [s]	39.21	31.27	34.52	41.51	31.45	28.19	42.24	39.54	22.44	42.52	37.04	37.05
k, delay calibration	0.04	0.15	0.45	0.04	0.15	0.15	0.04	0.11	0.11	0.04	0.11	0.11
l, Upstream Filtering Factor	1.00	1.00	1.00	1.00	1.00	1.00	1.00	1.00	1.00	1.00	1.00	1.00
d2, Incremental Delay [s]	0.08	1.05	22.14	0.07	0.26	0.13	0.29	1.34	0.32	0.22	0.85	0.89
d3, Initial Queue Delay [s]	0.00	0.00	0.00	0.00	0.00	0.00	0.00	0.00	0.00	0.00	0.00	0.00
Rp, platoon ratio	1.00	1.00	1.00	1.00	1.00	1.00	1.00	1.00	1.00	1.00	1.00	1.00
PF, progression factor	1.00	1.00	1.00	1.00	1.00	1.00	1.00	1.00	1.00	1.00	1.00	1.00

**Lane Group Results**

X, volume / capacity	0.35	0.70	0.92	0.19	0.49	0.16	0.52	0.73	0.47	0.56	0.47	0.48
d, Delay for Lane Group [s/veh]	39.30	32.33	56.66	41.58	31.72	28.31	42.53	40.88	22.76	42.75	37.88	37.95
Lane Group LOS	D	C	E	D	C	C	D	D	C	D	D	D
Critical Lane Group	No	No	Yes	Yes	No	No	No	No	Yes	Yes	No	No
50th-Percentile Queue Length [veh/ln]	2.61	9.81	15.68	1.09	5.33	1.30	3.46	7.14	4.57	3.74	4.54	4.35
50th-Percentile Queue Length [ft/ln]	65.20	245.18	392.02	27.23	133.22	32.53	86.55	178.51	114.14	93.58	113.39	108.74
95th-Percentile Queue Length [veh/ln]	4.69	14.94	22.18	1.96	9.11	2.34	6.23	11.52	8.07	6.74	8.03	7.77
95th-Percentile Queue Length [ft/ln]	117.36	373.58	554.38	49.02	227.87	58.56	155.79	288.07	201.74	168.44	200.71	194.25



**Movement, Approach, & Intersection Results**

d_M, Delay for Movement [s/veh]	39.30	32.33	56.66	41.58	31.72	28.31	42.53	40.88	22.76	42.75	37.91	37.95
Movement LOS	D	C	E	D	C	C	D	D	C	D	D	D
d_A, Approach Delay [s/veh]	40.89			32.08			34.45			40.55		
Approach LOS	D			C			C			D		
d_I, Intersection Delay [s/veh]	36.99											
Intersection LOS	D											
Intersection V/C	0.665											

**Emissions**

Vehicle Miles Traveled [mph]	68.31	176.00	102.36	26.82	291.27	39.51	250.61	509.13	452.85	553.45	236.01	226.00
Stops [stops/h]	258.73	648.65	518.56	72.05	704.91	86.06	228.98	472.26	301.96	371.35	149.99	143.84
Fuel consumption [US gal/h]	6.90	16.47	12.83	2.46	23.88	3.05	13.69	27.69	21.57	27.47	11.44	10.96
CO [g/h]	482.62	1151.47	896.97	171.63	1668.96	213.19	957.12	1935.74	1507.95	1920.43	799.63	766.02
NOx [g/h]	93.90	224.03	174.52	33.39	324.72	41.48	186.22	376.62	293.39	373.65	155.58	149.04
VOC [g/h]	111.85	266.86	207.88	39.78	386.80	49.41	221.82	448.63	349.48	445.08	185.32	177.53

**Other Modes**

g_Walk,mi, Effective Walk Time [s]	-6.0		8.0		8.0		8.0	
M_corner, Corner Circulation Area [ft <sup>2</sup> /ped]	0.00		0.00		0.00		0.00	
M_CW, Crosswalk Circulation Area [ft <sup>2</sup> /ped]	0.00		0.00		0.00		0.00	
d_p, Pedestrian Delay [s]	60.60		46.72		46.72		46.72	
I_p,int, Pedestrian LOS Score for Intersectio	3.347		3.294		3.176		3.064	
Crosswalk LOS	C		C		C		C	
s_b, Saturation Flow Rate of the bicycle lane	2000		2000		2000		2000	
c_b, Capacity of the bicycle lane [bicycles/h]	643		643		643		643	
d_b, Bicycle Delay [s]	25.07		25.06		25.07		25.06	
I_b,int, Bicycle LOS Score for Intersection	2.954		2.071		2.697		2.256	
Bicycle LOS	C		B		B		B	

**Sequence**

Ring 1	1	2	3	4	-	-	-	-	-	-	-	-	-	-	-
Ring 2	5	6	7	8	-	-	-	-	-	-	-	-	-	-	-
Ring 3	-	-	-	-	-	-	-	-	-	-	-	-	-	-	-
Ring 4	-	-	-	-	-	-	-	-	-	-	-	-	-	-	-



**Intersection Level Of Service Report**  
**Intersection 4: Tassajara Road & I-580 WB Ramps**

Control Type:	Signalized	Delay (sec / veh):	11.1
Analysis Method:	HCM 7th Edition	Level Of Service:	B
Analysis Period:	15 minutes	Volume to Capacity (v/c):	0.627

**Intersection Setup**

Name	Tassajara Road		Tassajara Road		I-580 WB Ramps	
Approach	Northbound		Southbound		Westbound	
Lane Configuration	↑↑		↑↑↑		←←←→→	
Turning Movement	Thru	Right	Left	Thru	Left	Right
Lane Width [ft]	12.00	12.00	12.00	12.00	12.00	12.00
No. of Lanes in Entry Pocket	0	0	0	0	1	1
Entry Pocket Length [ft]	100.00	100.00	100.00	100.00	100.00	100.00
No. of Lanes in Exit Pocket	0	1	0	0	0	0
Exit Pocket Length [ft]	0.00	49.21	0.00	0.00	0.00	0.00
Speed [mph]	30.00		30.00		30.00	
Grade [%]	0.00		0.00		0.00	
Curb Present	No		No		No	
Crosswalk	Yes		Yes		Yes	



**Volumes**

Name	Tassajara Road		Tassajara Road		I-580 WB Ramps	
Base Volume Input [veh/h]	1462	0	0	1305	489	240
Base Volume Adjustment Factor	1.0000	1.0000	1.0000	1.0000	1.0000	1.0000
Heavy Vehicles Percentage [%]	0.40	2.00	2.00	0.80	0.40	1.70
Proportion of CAVs [%]	0.00					
Growth Factor	1.0000	1.0000	1.0000	1.0000	1.0000	1.0000
In-Process Volume [veh/h]	0	0	0	0	0	0
Site-Generated Trips [veh/h]	0	0	0	0	0	0
Diverted Trips [veh/h]	0	0	0	0	0	0
Pass-by Trips [veh/h]	0	0	0	0	0	0
Existing Site Adjustment Volume [veh/h]	0	0	0	0	0	0
Other Volume [veh/h]	0	0	0	0	0	0
Right Turn on Red Volume [veh/h]	0	0	0	0	0	0
Total Hourly Volume [veh/h]	1462	0	0	1305	489	240
Peak Hour Factor	0.9600	1.0000	1.0000	0.9600	0.9600	0.9600
Other Adjustment Factor	1.0000	1.0000	1.0000	1.0000	1.0000	1.0000
Total 15-Minute Volume [veh/h]	381	0	0	340	127	63
Total Analysis Volume [veh/h]	1523	0	0	1359	509	250
Presence of On-Street Parking	No	No	No	No	No	No
On-Street Parking Maneuver Rate [/h]	0	0	0	0	0	0
Local Bus Stopping Rate [/h]	0	0	0	0	0	0
v_do, Outbound Pedestrian Volume crossing	0		0		0	
v_di, Inbound Pedestrian Volume crossing m	0		0		0	
v_co, Outbound Pedestrian Volume crossing	0		0		0	
v_ci, Inbound Pedestrian Volume crossing mi	0		0		0	
v_ab, Corner Pedestrian Volume [ped/h]	0		0		0	
Bicycle Volume [bicycles/h]	1		0		0	



**Intersection Settings**

Located in CBD	No
Signal Coordination Group	-
Cycle Length [s]	60
Active Pattern	Pattern 1
Coordination Type	Time of Day Pattern Coordinated
Actuation Type	Fully actuated
Offset [s]	29.0
Offset Reference	Beginning of First Yellow
Permissive Mode	SingleBand
Lost time [s]	6.00

**Phasing & Timing (Basic)**

Control Type	Permissive	Permissive	Permissive	Permissive	Permissive	Permissive
Signal Group	6	0	0	2	4	0
Auxiliary Signal Groups						
Maximum Green [s]	40	0	0	40	20	0
Amber [s]	4.9	0.0	0.0	4.9	4.4	0.0
All red [s]	1.0	0.0	0.0	1.0	1.0	0.0
Walk [s]	5	0	0	0	0	0
Pedestrian Clearance [s]	16	0	0	0	0	0
Delayed Vehicle Green [s]	0.0	0.0	0.0	0.0	0.0	0.0
Rest In Walk	No			No	No	
I1, Start-Up Lost Time [s]	2.0	0.0	0.0	2.0	2.0	0.0
I2, Clearance Lost Time [s]	3.9	0.0	0.0	3.9	3.4	0.0
Detector Location [ft]	0.0	0.0	0.0	0.0	0.0	0.0
Detector Length [ft]	20.0	0.0	0.0	20.0	20.0	0.0
I, Upstream Filtering Factor	1.00	1.00	1.00	1.00	1.00	1.00

**Phasing & Timing: Pattern 1**

Split [s]	36	0	0	36	24	0
Lead / Lag	-	-	-	-	Lead	-
Minimum Green [s]	7	0	0	7	4	0
Vehicle Extension [s]	3.0	0.0	0.0	3.0	2.0	0.0
Minimum Recall	No			No	No	
Maximum Recall	Yes			Yes	No	
Pedestrian Recall	Yes			No	No	

**Exclusive Pedestrian Phase**

Pedestrian Signal Group	0
Pedestrian Walk [s]	0
Pedestrian Clearance [s]	0



**Lane Group Calculations**

Lane Group	C	C	L	R
C, Cycle Length [s]	63	63	63	63
L, Total Lost Time per Cycle [s]	5.90	5.90	5.40	5.40
l1_p, Permitted Start-Up Lost Time [s]	0.00	0.00	0.00	0.00
l2, Clearance Lost Time [s]	3.90	3.90	3.40	3.40
g_i, Effective Green Time [s]	40	40	12	12
g / C, Green / Cycle	0.63	0.63	0.19	0.19
(v / s)_i Volume / Saturation Flow Rate	0.42	0.26	0.15	0.09
s, saturation flow rate [veh/h]	3606	5143	3503	2820
c, Capacity [veh/h]	2282	3255	660	531
d1, Uniform Delay [s]	7.38	5.79	24.36	22.84
k, delay calibration	0.50	0.50	0.04	0.04
l, Upstream Filtering Factor	1.00	1.00	1.00	1.00
d2, Incremental Delay [s]	1.57	0.40	0.73	0.24
d3, Initial Queue Delay [s]	0.00	0.00	0.00	0.00
Rp, platoon ratio	1.00	1.00	1.00	1.00
PF, progression factor	1.00	1.00	1.00	1.00

**Lane Group Results**

X, volume / capacity	0.67	0.42	0.77	0.47
d, Delay for Lane Group [s/veh]	8.94	6.19	25.09	23.08
Lane Group LOS	A	A	C	C
Critical Lane Group	Yes	No	Yes	No
50th-Percentile Queue Length [veh/ln]	5.17	2.30	3.45	1.58
50th-Percentile Queue Length [ft/ln]	129.34	57.60	86.29	39.42
95th-Percentile Queue Length [veh/ln]	8.90	4.15	6.21	2.84
95th-Percentile Queue Length [ft/ln]	222.60	103.68	155.32	70.95

**Movement, Approach, & Intersection Results**

d_M, Delay for Movement [s/veh]	8.94	0.00	0.00	6.19	25.09	23.08
Movement LOS	A			A	C	C
d_A, Approach Delay [s/veh]	8.94		6.19		24.43	
Approach LOS	A		A		C	
d_I, Intersection Delay [s/veh]	11.14					
Intersection LOS	B					
Intersection V/C	0.627					

**Emissions**

Vehicle Miles Traveled [mph]	256.45	278.77	41.16	20.22
Stops [stops/h]	589.82	393.98	393.48	179.75
Fuel consumption [US gal/h]	16.59	15.36	6.47	3.00
CO [g/h]	1159.48	1073.95	452.07	209.69
NOx [g/h]	225.59	208.95	87.96	40.80
VOC [g/h]	268.72	248.90	104.77	48.60

**Other Modes**

g_Walk,mi, Effective Walk Time [s]	18.6	18.6	9.0
M_corner, Corner Circulation Area [ft <sup>2</sup> /ped]	0.00	0.00	0.00
M_CW, Crosswalk Circulation Area [ft <sup>2</sup> /ped]	0.00	0.00	0.00
d_p, Pedestrian Delay [s]	15.72	15.72	23.22
I_p,int, Pedestrian LOS Score for Intersectio	2.929	2.878	2.431
Crosswalk LOS	C	C	B
s_b, Saturation Flow Rate of the bicycle lane	2000	2000	2000
c_b, Capacity of the bicycle lane [bicycles/h]	953	953	589
d_b, Bicycle Delay [s]	8.66	8.65	15.72
I_b,int, Bicycle LOS Score for Intersection	2.816	2.307	1.560
Bicycle LOS	C	B	A

**Sequence**

Ring 1	-	2	-	4	-	-	-	-	-	-	-	-	-	-	-	-
Ring 2	-	6	-	-	-	-	-	-	-	-	-	-	-	-	-	-
Ring 3	-	-	-	-	-	-	-	-	-	-	-	-	-	-	-	-
Ring 4	-	-	-	-	-	-	-	-	-	-	-	-	-	-	-	-



**Intersection Level Of Service Report**  
**Intersection 5: Santa Rita Rd & I-580 EB Ramps/Pimlico Dr**

Control Type:	Signalized	Delay (sec / veh):	33.2
Analysis Method:	HCM 7th Edition	Level Of Service:	C
Analysis Period:	15 minutes	Volume to Capacity (v/c):	0.810

**Intersection Setup**

Name	Santa Rita Road			Tassajara Road			I-580 EB Ramps			Pimlico Drive		
Approach	Northbound			Southbound			Eastbound			Westbound		
Lane Configuration	↑↑↑↑			↵↑↑			↵↑↑			↵↵↵↵		
Turning Movement	Left	Thru	Right	Left	Thru	Right	Left	Thru	Right	Left	Thru	Right
Lane Width [ft]	12.00	12.00	12.00	12.00	12.00	12.00	12.00	12.00	12.00	12.00	12.00	12.00
No. of Lanes in Entry Pocket	0	0	1	1	0	0	1	0	0	2	0	1
Entry Pocket Length [ft]	100.00	100.00	250.00	425.00	100.00	100.00	625.00	100.00	100.00	200.00	100.00	250.00
No. of Lanes in Exit Pocket	0	0	0	0	0	2	0	0	0	0	0	0
Exit Pocket Length [ft]	0.00	0.00	0.00	0.00	0.00	49.21	0.00	0.00	0.00	0.00	0.00	0.00
Speed [mph]	30.00			30.00			30.00			30.00		
Grade [%]	0.00			0.00			0.00			0.00		
Curb Present	No			No			No			No		
Crosswalk	Yes			No			Yes			Yes		





**Volumes**

Name	Santa Rita Road			Tassajara Road			I-580 EB Ramps			Pimlico Drive		
Base Volume Input [veh/h]	0	1741	85	256	1116	0	498	202	0	112	0	431
Base Volume Adjustment Factor	1.0000	1.0000	1.0000	1.0000	1.0000	1.0000	1.0000	1.0000	1.0000	1.0000	1.0000	1.0000
Heavy Vehicles Percentage [%]	2.00	0.30	1.20	0.40	0.40	2.00	1.20	0.50	2.00	0.00	2.00	0.00
Proportion of CAVs [%]	0.00											
Growth Factor	1.0000	1.0000	1.0000	1.0000	1.0000	1.0000	1.0000	1.0000	1.0000	1.0000	1.0000	1.0000
In-Process Volume [veh/h]	0	0	0	0	0	0	0	0	0	0	0	0
Site-Generated Trips [veh/h]	0	0	0	0	0	0	0	0	0	0	0	0
Diverted Trips [veh/h]	0	0	0	0	0	0	0	0	0	0	0	0
Pass-by Trips [veh/h]	0	0	0	0	0	0	0	0	0	0	0	0
Existing Site Adjustment Volume [veh/h]	0	0	0	0	0	0	0	0	0	0	0	0
Other Volume [veh/h]	0	0	0	0	0	0	0	0	0	0	0	0
Right Turn on Red Volume [veh/h]	0	0	0	0	0	0	0	0	0	0	0	0
Total Hourly Volume [veh/h]	0	1741	85	256	1116	0	498	202	0	112	0	431
Peak Hour Factor	1.0000	0.9600	0.9600	0.9600	0.9600	1.0000	0.9600	0.9600	1.0000	0.9600	1.0000	0.9600
Other Adjustment Factor	1.0000	1.0000	1.0000	1.0000	1.0000	1.0000	1.0000	1.0000	1.0000	1.0000	1.0000	1.0000
Total 15-Minute Volume [veh/h]	0	453	22	67	291	0	130	53	0	29	0	112
Total Analysis Volume [veh/h]	0	1814	89	267	1163	0	519	210	0	117	0	449
Presence of On-Street Parking	No		No	No		No	No		No	No		No
On-Street Parking Maneuver Rate [/h]	0	0	0	0	0	0	0	0	0	0	0	0
Local Bus Stopping Rate [/h]	0	0	0	0	0	0	0	0	0	0	0	0
v_do, Outbound Pedestrian Volume crossing	1			0			0			0		
v_di, Inbound Pedestrian Volume crossing m	0			0			1			0		
v_co, Outbound Pedestrian Volume crossing	0			2			3			1		
v_ci, Inbound Pedestrian Volume crossing mi	1			3			2			0		
v_ab, Corner Pedestrian Volume [ped/h]	0			0			0			0		
Bicycle Volume [bicycles/h]	1			0			0			0		



**Intersection Settings**

Located in CBD	No
Signal Coordination Group	-
Cycle Length [s]	120
Active Pattern	Pattern 1
Coordination Type	Time of Day Pattern Coordinated
Actuation Type	Fully actuated
Offset [s]	13.0
Offset Reference	Lead Green - Beginning of First Green
Permissive Mode	SingleBand
Lost time [s]	12.00

**Phasing & Timing (Basic)**

Control Type	Permiss	Permiss	Permiss	Protecte	Permiss	Permiss	Protecte	Permiss	Permiss	Permiss	Permiss	Overlap
Signal Group	0	6	0	5	2	0	3	8	0	7	0	4
Auxiliary Signal Groups												4,5
Maximum Green [s]	0	30	0	20	30	0	27	20	0	20	0	20
Amber [s]	0.0	4.4	0.0	3.0	4.4	0.0	4.4	4.4	0.0	3.5	0.0	3.5
All red [s]	0.0	1.0	0.0	1.0	1.0	0.0	1.0	1.0	0.0	1.0	0.0	1.0
Walk [s]	0	5	0	0	5	0	0	5	0	0	0	0
Pedestrian Clearance [s]	0	25	0	0	8	0	0	25	0	0	0	0
Delayed Vehicle Green [s]	0.0	0.0	0.0	0.0	0.0	0.0	0.0	0.0	0.0	0.0	0.0	0.0
Rest In Walk		No			No			No		No		
I1, Start-Up Lost Time [s]	0.0	2.0	0.0	2.0	2.0	0.0	2.0	2.0	0.0	2.0	0.0	2.0
I2, Clearance Lost Time [s]	0.0	3.4	0.0	2.0	3.4	0.0	3.4	3.4	0.0	2.5	0.0	2.5
Detector Location [ft]	0.0	0.0	0.0	0.0	0.0	0.0	0.0	0.0	0.0	0.0	0.0	0.0
Detector Length [ft]	0.0	0.0	0.0	0.0	0.0	0.0	0.0	0.0	0.0	0.0	0.0	0.0
I, Upstream Filtering Factor	1.00	1.00	1.00	1.00	1.00	1.00	1.00	1.00	1.00	1.00	1.00	1.00

**Phasing & Timing: Pattern 1**

Split [s]	0	40	0	28	68	0	32	36	0	16	0	20
Lead / Lag	-	-	-	Lead	-	-	Lead	-	-	Lead	-	-
Minimum Green [s]	0	7	0	5	7	0	5	5	0	5	0	5
Vehicle Extension [s]	0.0	3.0	0.0	3.0	3.0	0.0	3.0	2.0	0.0	3.0	0.0	2.0
Minimum Recall		No		No	No		No	No		No		No
Maximum Recall		Yes		No	Yes		No	No		No		No
Pedestrian Recall		No		No	Yes		No	No		No		No

**Exclusive Pedestrian Phase**

Pedestrian Signal Group	0
Pedestrian Walk [s]	0
Pedestrian Clearance [s]	0



**Lane Group Calculations**

Lane Group	C	C	L	C	L	C	L	R
C, Cycle Length [s]	120	120	120	120	120	120	120	120
L, Total Lost Time per Cycle [s]	5.40	5.40	4.00	5.40	5.40	5.40	4.50	4.00
l1_p, Permitted Start-Up Lost Time [s]	0.00	0.00	0.00	0.00	0.00	0.00	0.00	0.00
l2, Clearance Lost Time [s]	3.40	3.40	2.00	3.40	3.40	3.40	2.50	0.00
g_i, Effective Green Time [s]	53	53	20	76	20	23	6	32
g / C, Green / Cycle	0.44	0.44	0.16	0.63	0.17	0.19	0.05	0.27
(v / s)_i Volume / Saturation Flow Rate	0.33	0.26	0.15	0.32	0.15	0.11	0.03	0.16
s, saturation flow rate [veh/h]	4379	1826	1804	3606	3481	1892	3514	2859
c, Capacity [veh/h]	1919	801	293	2287	592	355	177	767
d1, Uniform Delay [s]	28.05	25.57	49.34	11.83	48.54	44.48	55.92	38.08
k, delay calibration	0.50	0.50	0.35	0.50	0.11	0.10	0.11	0.04
l, Upstream Filtering Factor	1.00	1.00	1.00	1.00	1.00	1.00	1.00	1.00
d2, Incremental Delay [s]	2.66	3.24	26.32	0.81	4.36	1.50	4.18	0.27
d3, Initial Queue Delay [s]	0.00	0.00	0.00	0.00	0.00	0.00	0.00	0.00
Rp, platoon ratio	1.00	1.00	1.00	1.00	1.00	1.00	1.00	1.00
PF, progression factor	1.00	1.00	1.00	1.00	1.00	1.00	1.00	1.00

**Lane Group Results**

X, volume / capacity	0.74	0.59	0.91	0.51	0.88	0.59	0.66	0.59
d, Delay for Lane Group [s/veh]	30.71	28.80	75.67	12.64	52.89	45.98	60.11	38.35
Lane Group LOS	C	C	E	B	D	D	E	D
Critical Lane Group	Yes	No	Yes	No	Yes	No	No	Yes
50th-Percentile Queue Length [veh/ln]	11.65	10.91	9.98	8.24	7.91	5.86	1.84	5.75
50th-Percentile Queue Length [ft/ln]	291.30	272.74	249.55	206.10	197.75	146.41	46.08	143.80
95th-Percentile Queue Length [veh/ln]	17.25	16.33	15.16	12.95	12.52	9.83	3.32	9.69
95th-Percentile Queue Length [ft/ln]	431.25	408.17	379.09	323.82	313.07	245.64	82.94	242.14

**Movement, Approach, & Intersection Results**

d_M, Delay for Movement [s/veh]	0.00	30.30	28.80	75.67	12.64	0.00	52.89	45.98	0.00	60.11	0.00	38.35
Movement LOS		C	C	E	B		D	D		E		D
d_A, Approach Delay [s/veh]	30.23			24.41			50.90			42.85		
Approach LOS	C			C			D			D		
d_I, Intersection Delay [s/veh]	33.23											
Intersection LOS	C											
Intersection V/C	0.810											

**Emissions**

Vehicle Miles Traveled [mph]	140.77	46.92	44.96	195.83	72.02	29.14	9.99	38.32
Stops [stops/h]	1049.16	327.44	299.60	494.87	474.83	175.78	110.64	345.29
Fuel consumption [US gal/h]	20.51	6.53	7.62	13.79	11.17	4.14	2.45	6.99
CO [g/h]	1433.67	456.40	532.42	963.81	781.03	289.08	171.49	488.54
NOx [g/h]	278.94	88.80	103.59	187.52	151.96	56.24	33.37	95.05
VOC [g/h]	332.27	105.78	123.39	223.37	181.01	67.00	39.74	113.22

**Other Modes**

g_Walk,mi, Effective Walk Time [s]	9.0	0.0	9.0	9.0
M_corner, Corner Circulation Area [ft <sup>2</sup> /ped]	0.00	0.00	0.00	0.00
M_CW, Crosswalk Circulation Area [ft <sup>2</sup> /ped]	6543.07	0.00	0.00	0.00
d_p, Pedestrian Delay [s]	51.31	0.00	51.31	51.31
I_p,int, Pedestrian LOS Score for Intersectio	2.985	0.000	2.324	2.536
Crosswalk LOS	C	F	B	B
s_b, Saturation Flow Rate of the bicycle lane	2000	2000	2000	2000
c_b, Capacity of the bicycle lane [bicycles/h]	577	1044	510	192
d_b, Bicycle Delay [s]	30.38	13.71	33.28	49.02
I_b,int, Bicycle LOS Score for Intersection	2.345	2.739	2.762	1.560
Bicycle LOS	B	B	C	A

**Sequence**



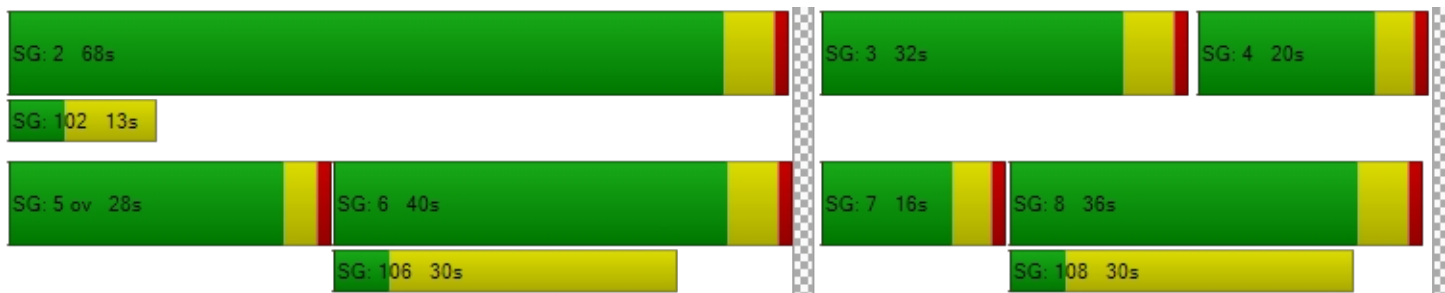

Ring 1	-	2	3	4	-	-	-	-	-	-	-	-	-	-	-
Ring 2	5	6	7	8	-	-	-	-	-	-	-	-	-	-	-
Ring 3	-	-	-	-	-	-	-	-	-	-	-	-	-	-	-
Ring 4	-	-	-	-	-	-	-	-	-	-	-	-	-	-	-



**Intersection Level Of Service Report**  
**Intersection 6: Tassajara Road & Fallon Road**

Control Type:	Signalized	Delay (sec / veh):	15.2
Analysis Method:	HCM 7th Edition	Level Of Service:	B
Analysis Period:	15 minutes	Volume to Capacity (v/c):	0.394

**Intersection Setup**

Name	Fallon Road			Fallon Road			Tassajara Road			Syrah Drive		
Approach	Northbound			Southbound			Eastbound			Westbound		
Lane Configuration												
Turning Movement	Left	Thru	Right	Left	Thru	Right	Left	Thru	Right	Left	Thru	Right
Lane Width [ft]	12.00	12.00	12.00	12.00	12.00	12.00	12.00	12.00	12.00	12.00	12.00	12.00
No. of Lanes in Entry Pocket	1	0	1	1	0	2	1	0	1	1	0	1
Entry Pocket Length [ft]	175.00	100.00	175.00	175.00	100.00	225.00	475.00	100.00	175.00	100.00	100.00	100.00
No. of Lanes in Exit Pocket	0	0	0	0	0	0	0	0	0	0	0	0
Exit Pocket Length [ft]	0.00	0.00	0.00	0.00	0.00	0.00	0.00	0.00	0.00	0.00	0.00	0.00
Speed [mph]	30.00			30.00			30.00			30.00		
Grade [%]	0.00			0.00			0.00			0.00		
Curb Present	No			No			No			No		
Crosswalk	Yes			Yes			Yes			Yes		



**Volumes**

Name	Fallon Road			Fallon Road			Tassajara Road			Syrah Drive		
Base Volume Input [veh/h]	60	318	21	4	244	331	401	23	60	4	17	5
Base Volume Adjustment Factor	1.0000	1.0000	1.0000	1.0000	1.0000	1.0000	1.0000	1.0000	1.0000	1.0000	1.0000	1.0000
Heavy Vehicles Percentage [%]	0.00	0.00	4.80	0.00	2.50	0.30	0.20	0.00	0.00	0.00	0.00	20.00
Proportion of CAVs [%]	0.00											
Growth Factor	1.0000	1.0000	1.0000	1.0000	1.0000	1.0000	1.0000	1.0000	1.0000	1.0000	1.0000	1.0000
In-Process Volume [veh/h]	0	0	0	0	0	0	0	0	0	0	0	0
Site-Generated Trips [veh/h]	0	0	0	0	0	0	0	0	0	0	0	0
Diverted Trips [veh/h]	0	0	0	0	0	0	0	0	0	0	0	0
Pass-by Trips [veh/h]	0	0	0	0	0	0	0	0	0	0	0	0
Existing Site Adjustment Volume [veh/h]	0	0	0	0	0	0	0	0	0	0	0	0
Other Volume [veh/h]	0	0	0	0	0	0	0	0	0	0	0	0
Right Turn on Red Volume [veh/h]	0	0	0	0	0	0	0	0	0	0	0	0
Total Hourly Volume [veh/h]	60	318	21	4	244	331	401	23	60	4	17	5
Peak Hour Factor	0.9200	0.9200	0.9200	0.9200	0.9200	0.9200	0.9200	0.9200	0.9200	0.9200	0.9200	0.9200
Other Adjustment Factor	1.0000	1.0000	1.0000	1.0000	1.0000	1.0000	1.0000	1.0000	1.0000	1.0000	1.0000	1.0000
Total 15-Minute Volume [veh/h]	16	86	6	1	66	90	109	6	16	1	5	1
Total Analysis Volume [veh/h]	65	346	23	4	265	360	436	25	65	4	18	5
Presence of On-Street Parking	No		No	No		No	No		No	No		No
On-Street Parking Maneuver Rate [/h]	0	0	0	0	0	0	0	0	0	0	0	0
Local Bus Stopping Rate [/h]	0	0	0	0	0	0	0	0	0	0	0	0
v_do, Outbound Pedestrian Volume crossing	0			0			0			0		
v_di, Inbound Pedestrian Volume crossing m	0			0			0			0		
v_co, Outbound Pedestrian Volume crossing	0			0			0			0		
v_ci, Inbound Pedestrian Volume crossing mi	0			0			0			0		
v_ab, Corner Pedestrian Volume [ped/h]	0			0			0			0		
Bicycle Volume [bicycles/h]	0			0			0			0		



**Intersection Settings**

Located in CBD	No
Signal Coordination Group	-
Cycle Length [s]	90
Active Pattern	Free Running (No Pattern)
Coordination Type	<i>Free Running</i>
Actuation Type	<i>Fully actuated</i>
Offset [s]	0.0
Offset Reference	Lead Green - Beginning of First Green
Permissive Mode	SingleBand
Lost time [s]	12.00

**Phasing & Timing (Basic)**

Control Type	Protecte	Permiss	Permiss	Protecte	Permiss	Permiss	Protecte	Permiss	Permiss	Protecte	Permiss	Permiss
Signal Group	3	8	0	7	4	0	5	2	0	1	6	0
Auxiliary Signal Groups												
Maximum Green [s]	25	50	0	25	50	0	35	30	0	20	30	0
Amber [s]	3.5	4.8	0.0	3.5	4.8	0.0	3.5	5.0	0.0	3.0	3.6	0.0
All red [s]	1.0	1.0	0.0	1.0	1.0	0.0	1.0	1.0	0.0	1.0	1.0	0.0
Walk [s]	0	4	0	0	0	0	0	4	0	0	3	0
Pedestrian Clearance [s]	0	25	0	0	0	0	0	28	0	0	36	0
Delayed Vehicle Green [s]	0.0	0.0	0.0	0.0	0.0	0.0	0.0	0.0	0.0	0.0	0.0	0.0
Rest In Walk		No			No			No			No	
I1, Start-Up Lost Time [s]	2.0	2.0	0.0	2.0	2.0	0.0	2.0	2.0	0.0	2.0	2.0	0.0
I2, Clearance Lost Time [s]	2.0	2.0	0.0	2.0	2.0	0.0	2.0	2.0	0.0	2.0	2.0	0.0
Detector Location [ft]	0.0	0.0	0.0	0.0	0.0	0.0	0.0	0.0	0.0	0.0	0.0	0.0
Detector Length [ft]	0.0	0.0	0.0	0.0	0.0	0.0	0.0	0.0	0.0	0.0	0.0	0.0
I, Upstream Filtering Factor	1.00	1.00	1.00	1.00	1.00	1.00	1.00	1.00	1.00	1.00	1.00	1.00

**Phasing & Timing: Free Running (No Pattern)**

Split [s]	0	0	0	0	0	0	0	0	0	0	0	0
Lead / Lag	Lead	-	-	Lead	-	-	Lead	-	-	Lead	-	-
Minimum Green [s]	9	10	0	9	10	0	11	8	0	12	9	0
Vehicle Extension [s]	3.0	3.0	0.0	3.0	3.0	0.0	3.0	3.0	0.0	3.0	3.0	0.0
Minimum Recall	No	No		No	No		Yes	No		No	No	
Maximum Recall	No	No		No	No		No	No		No	No	
Pedestrian Recall	No	No		No	No		No	No		No	No	

**Exclusive Pedestrian Phase**

Pedestrian Signal Group	0
Pedestrian Walk [s]	0
Pedestrian Clearance [s]	0



**Lane Group Calculations**

Lane Group	L	C	R	L	C	R	L	C	R	L	C	R
C, Cycle Length [s]	48	48	48	48	48	48	48	48	48	48	48	48
L, Total Lost Time per Cycle [s]	4.00	4.00	4.00	4.00	4.00	4.00	4.00	4.00	4.00	4.00	4.00	4.00
l1_p, Permitted Start-Up Lost Time [s]	0.00	0.00	0.00	0.00	0.00	0.00	0.00	0.00	0.00	0.00	0.00	0.00
l2, Clearance Lost Time [s]	2.00	2.00	2.00	2.00	2.00	2.00	2.00	2.00	2.00	2.00	2.00	2.00
g_i, Effective Green Time [s]	6	17	17	1	12	12	11	14	14	1	3	3
g / C, Green / Cycle	0.12	0.35	0.35	0.02	0.25	0.25	0.24	0.29	0.29	0.01	0.06	0.06
(v / s)_i Volume / Saturation Flow Rate	0.04	0.10	0.01	0.00	0.07	0.13	0.12	0.01	0.04	0.00	0.01	0.00
s, saturation flow rate [veh/h]	1810	3618	1554	1810	3546	2852	3509	1900	1615	1810	1900	1360
c, Capacity [veh/h]	220	1252	538	38	871	700	836	548	466	25	122	87
d1, Uniform Delay [s]	19.36	11.44	10.50	23.24	14.88	15.76	16.03	12.41	12.76	23.57	21.39	21.27
k, delay calibration	0.11	0.11	0.11	0.11	0.11	0.11	0.11	0.11	0.11	0.11	0.11	0.11
l, Upstream Filtering Factor	1.00	1.00	1.00	1.00	1.00	1.00	1.00	1.00	1.00	1.00	1.00	1.00
d2, Incremental Delay [s]	0.74	0.12	0.03	1.21	0.20	0.59	0.51	0.03	0.14	2.91	0.55	0.27
d3, Initial Queue Delay [s]	0.00	0.00	0.00	0.00	0.00	0.00	0.00	0.00	0.00	0.00	0.00	0.00
Rp, platoon ratio	1.00	1.00	1.00	1.00	1.00	1.00	1.00	1.00	1.00	1.00	1.00	1.00
PF, progression factor	1.00	1.00	1.00	1.00	1.00	1.00	1.00	1.00	1.00	1.00	1.00	1.00

**Lane Group Results**

X, volume / capacity	0.30	0.28	0.04	0.11	0.30	0.51	0.52	0.05	0.14	0.16	0.15	0.06
d, Delay for Lane Group [s/veh]	20.10	11.56	10.53	24.44	15.08	16.34	16.53	12.45	12.90	26.48	21.95	21.54
Lane Group LOS	C	B	B	C	B	B	B	B	B	C	C	C
Critical Lane Group	Yes	No	No	No	No	Yes	Yes	No	No	No	Yes	No
50th-Percentile Queue Length [veh/ln]	0.64	1.14	0.14	0.05	1.06	1.54	1.88	0.17	0.47	0.06	0.19	0.06
50th-Percentile Queue Length [ft/ln]	16.11	28.61	3.55	1.34	26.41	38.58	46.95	4.34	11.69	1.54	4.85	1.38
95th-Percentile Queue Length [veh/ln]	1.16	2.06	0.26	0.10	1.90	2.78	3.38	0.31	0.84	0.11	0.35	0.10
95th-Percentile Queue Length [ft/ln]	29.00	51.50	6.39	2.42	47.55	69.44	84.51	7.81	21.03	2.78	8.74	2.48





**Movement, Approach, & Intersection Results**

d_M, Delay for Movement [s/veh]	20.10	11.56	10.53	24.44	15.08	16.34	16.53	12.45	12.90	26.48	21.95	21.54
Movement LOS	C	B	B	C	B	B	B	B	B	C	C	C
d_A, Approach Delay [s/veh]	12.78			15.86			15.89			22.54		
Approach LOS	B			B			B			C		
d_I, Intersection Delay [s/veh]	15.16											
Intersection LOS	B											
Intersection V/C	0.394											

**Emissions**

Vehicle Miles Traveled [mph]	6.19	32.97	2.19	0.43	28.76	39.08	56.23	3.22	8.38	0.14	0.65	0.18
Stops [stops/h]	48.15	171.01	10.61	4.01	157.87	230.54	280.60	12.96	34.92	4.61	14.51	4.11
Fuel consumption [US gal/h]	0.79	3.12	0.20	0.06	2.87	4.08	5.33	0.27	0.71	0.05	0.19	0.05
CO [g/h]	55.01	217.80	13.85	4.19	200.57	285.18	372.72	18.71	49.53	3.70	13.08	3.64
NOx [g/h]	10.70	42.38	2.69	0.82	39.02	55.49	72.52	3.64	9.64	0.72	2.55	0.71
VOC [g/h]	12.75	50.48	3.21	0.97	46.48	66.09	86.38	4.34	11.48	0.86	3.03	0.84

**Other Modes**

g_Walk,mi, Effective Walk Time [s]	8.0			7.0			-5.8			8.0		
M_corner, Corner Circulation Area [ft <sup>2</sup> /ped]	0.00			0.00			0.00			0.00		
M_CW, Crosswalk Circulation Area [ft <sup>2</sup> /ped]	0.00			0.00			0.00			0.00		
d_p, Pedestrian Delay [s]	16.76			17.60			30.24			16.76		
I_p,int, Pedestrian LOS Score for Intersectio	2.548			2.763			2.604			2.121		
Crosswalk LOS	B			C			B			B		
s_b, Saturation Flow Rate of the bicycle lane	2000			2000			2000			2000		
c_b, Capacity of the bicycle lane [bicycles/h]	2075			2075			1245			1245		
d_b, Bicycle Delay [s]	0.03			0.03			3.43			3.43		
I_b,int, Bicycle LOS Score for Intersection	1.918			2.079			2.428			1.604		
Bicycle LOS	A			B			B			A		

**Sequence**

Ring 1	1	2	3	4	-	-	-	-	-	-	-	-	-	-	-
Ring 2	5	6	7	8	-	-	-	-	-	-	-	-	-	-	-
Ring 3	-	-	-	-	-	-	-	-	-	-	-	-	-	-	-
Ring 4	-	-	-	-	-	-	-	-	-	-	-	-	-	-	-



**Intersection Level Of Service Report**  
**Intersection 7: Fallon Road & Positano Parkway**

Control Type:	Signalized	Delay (sec / veh):	9.3
Analysis Method:	HCM 7th Edition	Level Of Service:	A
Analysis Period:	15 minutes	Volume to Capacity (v/c):	0.500

**Intersection Setup**

Name	Fallon Road		Fallon Road		Positano Parkway	
Approach	Northbound		Southbound		Westbound	
Lane Configuration	↑↑↑↔		↔↑↑↑		↔↔↔	
Turning Movement	Thru	Right	Left	Thru	Left	Right
Lane Width [ft]	12.00	12.00	12.00	12.00	12.00	12.00
No. of Lanes in Entry Pocket	0	1	1	0	1	1
Entry Pocket Length [ft]	100.00	225.00	325.00	100.00	375.00	425.00
No. of Lanes in Exit Pocket	0	0	0	0	0	0
Exit Pocket Length [ft]	0.00	0.00	0.00	0.00	0.00	0.00
Speed [mph]	30.00		30.00		30.00	
Grade [%]	0.00		0.00		0.00	
Curb Present	No		No		No	
Crosswalk	Yes		Yes		Yes	



**Volumes**

Name	Fallon Road		Fallon Road		Positano Parkway	
Base Volume Input [veh/h]	503	349	95	408	294	101
Base Volume Adjustment Factor	1.0000	1.0000	1.0000	1.0000	1.0000	1.0000
Heavy Vehicles Percentage [%]	0.20	0.00	0.00	1.50	0.00	0.00
Proportion of CAVs [%]	0.00					
Growth Factor	1.0000	1.0000	1.0000	1.0000	1.0000	1.0000
In-Process Volume [veh/h]	0	0	0	0	0	0
Site-Generated Trips [veh/h]	0	0	0	0	0	0
Diverted Trips [veh/h]	0	0	0	0	0	0
Pass-by Trips [veh/h]	0	0	0	0	0	0
Existing Site Adjustment Volume [veh/h]	0	0	0	0	0	0
Other Volume [veh/h]	0	0	0	0	0	0
Right Turn on Red Volume [veh/h]	0	0	0	0	0	0
Total Hourly Volume [veh/h]	503	349	95	408	294	101
Peak Hour Factor	0.9300	0.9300	0.9300	0.9300	0.9300	0.9300
Other Adjustment Factor	1.0000	1.0000	1.0000	1.0000	1.0000	1.0000
Total 15-Minute Volume [veh/h]	135	94	26	110	79	27
Total Analysis Volume [veh/h]	541	375	102	439	316	109
Presence of On-Street Parking	No	No	No	No	No	No
On-Street Parking Maneuver Rate [/h]	0	0	0	0	0	0
Local Bus Stopping Rate [/h]	0	0	0	0	0	0
v_do, Outbound Pedestrian Volume crossing	0		1		0	
v_di, Inbound Pedestrian Volume crossing m	0		0		1	
v_co, Outbound Pedestrian Volume crossing	0		0		1	
v_ci, Inbound Pedestrian Volume crossing mi	1		0		0	
v_ab, Corner Pedestrian Volume [ped/h]	0		0		0	
Bicycle Volume [bicycles/h]	0		0		0	



**Intersection Settings**

Located in CBD	No
Signal Coordination Group	-
Cycle Length [s]	90
Active Pattern	Free Running (No Pattern)
Coordination Type	<i>Free Running</i>
Actuation Type	<i>Fully actuated</i>
Offset [s]	0.0
Offset Reference	Lead Green - Beginning of First Green
Permissive Mode	SingleBand
Lost time [s]	9.00

**Phasing & Timing (Basic)**

Control Type	Permissive	Permissive	Protected	Permissive	Permissive	Permissive
Signal Group	4	0	7	8	6	0
Auxiliary Signal Groups						
Maximum Green [s]	30	0	20	30	24	0
Amber [s]	4.3	0.0	3.5	4.3	4.0	0.0
All red [s]	1.0	0.0	1.0	1.0	1.0	0.0
Walk [s]	0	0	0	4	4	0
Pedestrian Clearance [s]	0	0	0	20	34	0
Delayed Vehicle Green [s]	0.0	0.0	0.0	0.0	0.0	0.0
Rest In Walk	No			No	No	
I1, Start-Up Lost Time [s]	2.0	0.0	2.0	2.0	2.0	0.0
I2, Clearance Lost Time [s]	2.0	0.0	2.0	2.0	2.0	0.0
Detector Location [ft]	0.0	0.0	0.0	0.0	0.0	0.0
Detector Length [ft]	20.0	0.0	20.0	20.0	20.0	0.0
I, Upstream Filtering Factor	1.00	1.00	1.00	1.00	1.00	1.00

**Phasing & Timing: Free Running (No Pattern)**

Split [s]	14	0	9	14	9	0
Lead / Lag	-	-	Lead	-	Lead	-
Minimum Green [s]	10	0	5	10	5	0
Vehicle Extension [s]	3.0	0.0	3.0	3.0	3.0	0.0
Minimum Recall	Yes		No	Yes	No	
Maximum Recall	No		No	No	No	
Pedestrian Recall	No		No	No	No	

**Exclusive Pedestrian Phase**

Pedestrian Signal Group	0
Pedestrian Walk [s]	0
Pedestrian Clearance [s]	0



**Lane Group Calculations**

Lane Group	C	R	L	C	L	R
C, Cycle Length [s]	37	37	37	37	37	37
L, Total Lost Time per Cycle [s]	4.00	4.00	4.00	4.00	4.00	4.00
l1_p, Permitted Start-Up Lost Time [s]	0.00	0.00	0.00	0.00	0.00	0.00
l2, Clearance Lost Time [s]	2.00	2.00	2.00	2.00	2.00	2.00
g_i, Effective Green Time [s]	14	14	4	22	7	7
g / C, Green / Cycle	0.37	0.37	0.10	0.58	0.20	0.20
(v / s)_i Volume / Saturation Flow Rate	0.10	0.23	0.06	0.09	0.09	0.07
s, saturation flow rate [veh/h]	5167	1615	1810	5114	3514	1613
c, Capacity [veh/h]	1922	601	186	2978	710	326
d1, Uniform Delay [s]	8.17	9.53	15.84	3.54	12.98	12.67
k, delay calibration	0.11	0.11	0.11	0.11	0.11	0.11
l, Upstream Filtering Factor	1.00	1.00	1.00	1.00	1.00	1.00
d2, Incremental Delay [s]	0.08	1.07	2.53	0.02	0.44	0.60
d3, Initial Queue Delay [s]	0.00	0.00	0.00	0.00	0.00	0.00
Rp, platoon ratio	1.00	1.00	1.00	1.00	1.00	1.00
PF, progression factor	1.00	1.00	1.00	1.00	1.00	1.00

**Lane Group Results**

X, volume / capacity	0.28	0.62	0.55	0.15	0.44	0.33
d, Delay for Lane Group [s/veh]	8.25	10.60	18.37	3.56	13.42	13.27
Lane Group LOS	A	B	B	A	B	B
Critical Lane Group	No	Yes	Yes	No	Yes	No
50th-Percentile Queue Length [veh/ln]	0.73	1.92	0.82	0.23	0.97	0.68
50th-Percentile Queue Length [ft/ln]	18.34	48.07	20.38	5.80	24.15	16.88
95th-Percentile Queue Length [veh/ln]	1.32	3.46	1.47	0.42	1.74	1.22
95th-Percentile Queue Length [ft/ln]	33.01	86.52	36.69	10.44	43.47	30.39

**Movement, Approach, & Intersection Results**

d_M, Delay for Movement [s/veh]	8.25	10.60	18.37	3.56	13.42	13.27
Movement LOS	A	B	B	A	B	B
d_A, Approach Delay [s/veh]	9.21		6.36		13.38	
Approach LOS	A		A		B	
d_I, Intersection Delay [s/veh]	9.33					
Intersection LOS	A					
Intersection V/C	0.500					

**Emissions**

Vehicle Miles Traveled [mph]	136.07	94.32	8.95	38.52	37.89	13.07
Stops [stops/h]	214.24	187.19	79.37	67.77	188.07	65.75
Fuel consumption [US gal/h]	7.69	5.73	1.19	2.28	3.46	1.20
CO [g/h]	537.81	400.25	83.06	159.26	242.00	83.58
NOx [g/h]	104.64	77.87	16.16	30.99	47.08	16.26
VOC [g/h]	124.64	92.76	19.25	36.91	56.09	19.37

**Other Modes**

g_Walk,mi, Effective Walk Time [s]	8.0		8.0		8.7	
M_corner, Corner Circulation Area [ft <sup>2</sup> /ped]	0.00		0.00		0.00	
M_CW, Crosswalk Circulation Area [ft <sup>2</sup> /ped]	0.00		0.00		0.00	
d_p, Pedestrian Delay [s]	11.35		11.35		10.81	
I_p,int, Pedestrian LOS Score for Intersectio	2.781		2.715		2.304	
Crosswalk LOS	C		B		B	
s_b, Saturation Flow Rate of the bicycle lane	2000		2000		2000	
c_b, Capacity of the bicycle lane [bicycles/h]	1623		1623		1298	
d_b, Bicycle Delay [s]	0.66		0.66		2.28	
I_b,int, Bicycle LOS Score for Intersection	2.063		1.857		1.560	
Bicycle LOS	B		A		A	

**Sequence**

Ring 1	-	-	-	8	-	-	-	-	-	-	-	-	-	-	-	-
Ring 2	-	6	7	4	-	-	-	-	-	-	-	-	-	-	-	-
Ring 3	-	-	-	-	-	-	-	-	-	-	-	-	-	-	-	-
Ring 4	-	-	-	-	-	-	-	-	-	-	-	-	-	-	-	-

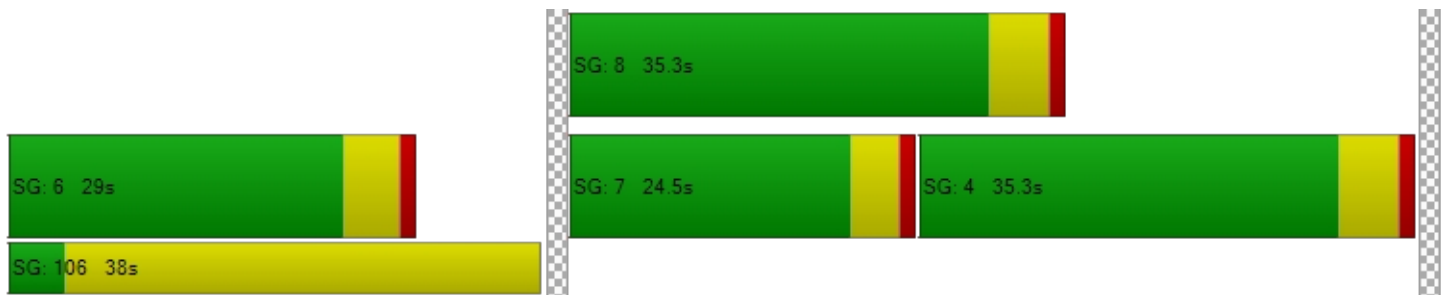

**Intersection Level Of Service Report**  
**Intersection 8: Fallon Road & Central Parkway**

Control Type:	Signalized	Delay (sec / veh):	20.9
Analysis Method:	HCM 7th Edition	Level Of Service:	C
Analysis Period:	15 minutes	Volume to Capacity (v/c):	0.359

**Intersection Setup**

Name	Fallon Road			Fallon Road			Central Parkway			Central Parkway		
Approach	Northbound			Southbound			Eastbound			Westbound		
Lane Configuration												
Turning Movement	Left	Thru	Right	Left	Thru	Right	Left	Thru	Right	Left	Thru	Right
Lane Width [ft]	12.00	12.00	12.00	12.00	12.00	12.00	12.00	12.00	12.00	12.00	12.00	12.00
No. of Lanes in Entry Pocket	2	0	1	1	0	1	2	0	2	2	0	1
Entry Pocket Length [ft]	300.00	100.00	255.00	295.00	100.00	245.00	350.00	100.00	230.00	250.00	100.00	250.00
No. of Lanes in Exit Pocket	0	0	1	0	0	2	0	0	0	0	0	0
Exit Pocket Length [ft]	0.00	0.00	250.00	0.00	0.00	500.00	0.00	0.00	0.00	0.00	0.00	0.00
Speed [mph]	40.00			30.00			25.00			30.00		
Grade [%]	0.00			0.00			0.00			0.00		
Curb Present	Yes			Yes			Yes			Yes		
Crosswalk	Yes			Yes			Yes			Yes		



**Volumes**

Name	Fallon Road			Fallon Road			Central Parkway			Central Parkway		
Base Volume Input [veh/h]	134	846	167	32	751	108	99	45	111	175	40	35
Base Volume Adjustment Factor	1.0000	1.0000	1.0000	1.0000	1.0000	1.0000	1.0000	1.0000	1.0000	1.0000	1.0000	1.0000
Heavy Vehicles Percentage [%]	0.70	0.10	0.00	0.00	0.40	0.00	0.00	0.00	0.00	0.00	0.00	0.00
Proportion of CAVs [%]	0.00											
Growth Factor	1.0000	1.0000	1.0000	1.0000	1.0000	1.0000	1.0000	1.0000	1.0000	1.0000	1.0000	1.0000
In-Process Volume [veh/h]	0	0	0	0	0	0	0	0	0	0	0	0
Site-Generated Trips [veh/h]	0	0	0	0	0	0	0	0	0	0	0	0
Diverted Trips [veh/h]	0	0	0	0	0	0	0	0	0	0	0	0
Pass-by Trips [veh/h]	0	0	0	0	0	0	0	0	0	0	0	0
Existing Site Adjustment Volume [veh/h]	0	0	0	0	0	0	0	0	0	0	0	0
Other Volume [veh/h]	0	0	0	0	0	0	0	0	0	0	0	0
Right Turn on Red Volume [veh/h]	0	0	0	0	0	0	0	0	0	0	0	0
Total Hourly Volume [veh/h]	134	846	167	32	751	108	99	45	111	175	40	35
Peak Hour Factor	0.9200	0.9200	0.9200	0.9200	0.9200	0.9200	0.9200	0.9200	0.9200	0.9200	0.9200	0.9200
Other Adjustment Factor	1.0000	1.0000	1.0000	1.0000	1.0000	1.0000	1.0000	1.0000	1.0000	1.0000	1.0000	1.0000
Total 15-Minute Volume [veh/h]	36	230	45	9	204	29	27	12	30	48	11	10
Total Analysis Volume [veh/h]	146	920	182	35	816	117	108	49	121	190	43	38
Presence of On-Street Parking	No		No	No		No	No		No	No		No
On-Street Parking Maneuver Rate [/h]	0	0	0	0	0	0	0	0	0	0	0	0
Local Bus Stopping Rate [/h]	0	0	0	0	0	0	0	0	0	0	0	0
v_do, Outbound Pedestrian Volume crossing	1			4			4			1		
v_di, Inbound Pedestrian Volume crossing m	1			4			4			1		
v_co, Outbound Pedestrian Volume crossing	2			6			1			5		
v_ci, Inbound Pedestrian Volume crossing mi	1			5			2			6		
v_ab, Corner Pedestrian Volume [ped/h]	0			0			0			0		
Bicycle Volume [bicycles/h]	0			1			0			0		





**Intersection Settings**

Located in CBD	No
Signal Coordination Group	-
Cycle Length [s]	90
Active Pattern	Free Running (No Pattern)
Coordination Type	<i>Free Running</i>
Actuation Type	<i>Fully actuated</i>
Offset [s]	0.0
Offset Reference	Lead Green - Beginning of First Green
Permissive Mode	SingleBand
Lost time [s]	12.00

**Phasing & Timing (Basic)**

Control Type	Protecte	Permiss	Permiss	Protecte	Permiss	Permiss	Protecte	Permiss	Permiss	Protecte	Permiss	Permiss
Signal Group	3	8	0	7	4	0	5	2	0	1	6	0
Auxiliary Signal Groups												
Maximum Green [s]	20	30	0	20	30	0	20	30	0	20	30	0
Amber [s]	3.5	4.3	0.0	3.0	4.3	0.0	3.0	4.0	0.0	3.0	4.0	0.0
All red [s]	1.0	1.0	0.0	1.0	1.0	0.0	1.0	1.0	0.0	1.0	1.0	0.0
Walk [s]	0	4	0	0	4	0	0	4	0	0	4	0
Pedestrian Clearance [s]	0	28	0	0	34	0	0	42	0	0	41	0
Delayed Vehicle Green [s]	0.0	0.0	0.0	0.0	0.0	0.0	0.0	0.0	0.0	0.0	0.0	0.0
Rest In Walk		No			No			No			No	
I1, Start-Up Lost Time [s]	2.0	2.0	0.0	2.0	2.0	0.0	2.0	2.0	0.0	2.0	2.0	0.0
I2, Clearance Lost Time [s]	2.0	2.0	0.0	2.0	2.0	0.0	2.0	2.0	0.0	2.0	2.0	0.0
Detector Location [ft]	0.0	0.0	0.0	0.0	0.0	0.0	0.0	0.0	0.0	0.0	0.0	0.0
Detector Length [ft]	20.0	20.0	0.0	20.0	20.0	0.0	20.0	20.0	0.0	20.0	20.0	0.0
I, Upstream Filtering Factor	1.00	1.00	1.00	1.00	1.00	1.00	1.00	1.00	1.00	1.00	1.00	1.00

**Phasing & Timing: Free Running (No Pattern)**

Split [s]	0	0	0	0	0	0	0	0	0	0	0	0
Lead / Lag	Lead	-	-	Lead	-	-	Lead	-	-	Lead	-	-
Minimum Green [s]	10	12	0	10	12	0	10	12	0	10	12	0
Vehicle Extension [s]	2.0	4.0	0.0	2.0	4.0	0.0	2.0	4.0	0.0	2.0	4.0	0.0
Minimum Recall	No	Yes		No	Yes		No	No		No	No	
Maximum Recall	No	No		No	No		No	No		No	No	
Pedestrian Recall	No	No		No	No		No	No		No	No	

**Exclusive Pedestrian Phase**

Pedestrian Signal Group	0
Pedestrian Walk [s]	0
Pedestrian Clearance [s]	0



**Lane Group Calculations**

Lane Group	L	C	R	L	C	R	L	C	R	L	C	R
C, Cycle Length [s]	69	69	69	69	69	69	69	69	69	69	69	69
L, Total Lost Time per Cycle [s]	4.00	4.00	4.00	4.00	4.00	4.00	4.00	4.00	4.00	4.00	4.00	4.00
l1_p, Permitted Start-Up Lost Time [s]	0.00	0.00	0.00	0.00	0.00	0.00	0.00	0.00	0.00	0.00	0.00	0.00
l2, Clearance Lost Time [s]	2.00	2.00	2.00	2.00	2.00	2.00	2.00	2.00	2.00	2.00	2.00	2.00
g_i, Effective Green Time [s]	10	25	25	5	20	20	9	14	14	10	15	15
g / C, Green / Cycle	0.14	0.36	0.36	0.07	0.29	0.29	0.13	0.20	0.20	0.14	0.21	0.21
(v / s)_i Volume / Saturation Flow Rate	0.04	0.18	0.11	0.02	0.16	0.07	0.03	0.03	0.04	0.05	0.02	0.02
s, saturation flow rate [veh/h]	3495	5172	1611	1810	5159	1581	3514	1900	2845	3514	1900	1590
c, Capacity [veh/h]	502	1857	578	130	1483	454	447	374	560	496	400	335
d1, Uniform Delay [s]	26.48	17.28	16.01	30.40	20.87	18.94	27.19	22.91	23.31	26.98	22.05	22.07
k, delay calibration	0.04	0.15	0.15	0.04	0.15	0.15	0.04	0.15	0.15	0.04	0.15	0.15
l, Upstream Filtering Factor	1.00	1.00	1.00	1.00	1.00	1.00	1.00	1.00	1.00	1.00	1.00	1.00
d2, Incremental Delay [s]	0.12	0.29	0.44	0.41	0.46	0.42	0.10	0.22	0.27	0.18	0.17	0.21
d3, Initial Queue Delay [s]	0.00	0.00	0.00	0.00	0.00	0.00	0.00	0.00	0.00	0.00	0.00	0.00
Rp, platoon ratio	1.00	1.00	1.00	1.00	1.00	1.00	1.00	1.00	1.00	1.00	1.00	1.00
PF, progression factor	1.00	1.00	1.00	1.00	1.00	1.00	1.00	1.00	1.00	1.00	1.00	1.00

**Lane Group Results**

X, volume / capacity	0.29	0.50	0.31	0.27	0.55	0.26	0.24	0.13	0.22	0.38	0.11	0.11
d, Delay for Lane Group [s/veh]	26.60	17.57	16.45	30.81	21.33	19.36	27.30	23.13	23.58	27.16	22.21	22.28
Lane Group LOS	C	B	B	C	C	B	C	C	C	C	C	C
Critical Lane Group	Yes	No	No	No	Yes	No	No	No	Yes	Yes	No	No
50th-Percentile Queue Length [veh/ln]	1.01	3.39	1.91	0.55	3.55	1.41	0.79	0.66	0.83	1.38	0.56	0.50
50th-Percentile Queue Length [ft/ln]	25.14	84.78	47.69	13.69	88.75	35.37	19.78	16.62	20.67	34.43	13.94	12.41
95th-Percentile Queue Length [veh/ln]	1.81	6.10	3.43	0.99	6.39	2.55	1.42	1.20	1.49	2.48	1.00	0.89
95th-Percentile Queue Length [ft/ln]	45.25	152.60	85.84	24.64	159.76	63.67	35.61	29.91	37.21	61.98	25.09	22.34



**Movement, Approach, & Intersection Results**

d_M, Delay for Movement [s/veh]	26.60	17.57	16.45	30.81	21.33	19.36	27.30	23.13	23.58	27.16	22.21	22.28
Movement LOS	C	B	B	C	C	B	C	C	C	C	C	C
d_A, Approach Delay [s/veh]	18.47			21.43			24.94			25.69		
Approach LOS	B			C			C			C		
d_I, Intersection Delay [s/veh]	20.86											
Intersection LOS	C											
Intersection V/C	0.359											

**Emissions**

Vehicle Miles Traveled [mph]	38.66	243.59	48.19	8.80	205.23	29.43	9.44	4.28	10.58	43.19	9.78	8.64
Stops [stops/h]	104.84	530.36	99.45	28.55	555.22	73.76	82.50	34.65	86.21	143.59	29.07	25.89
Fuel consumption [US gal/h]	3.20	17.23	3.31	0.74	15.06	2.08	1.34	0.56	1.39	3.62	0.76	0.67
CO [g/h]	224.03	1204.09	231.54	51.69	1052.51	145.39	93.73	38.88	96.94	253.14	52.94	46.90
NOx [g/h]	43.59	234.27	45.05	10.06	204.78	28.29	18.24	7.56	18.86	49.25	10.30	9.12
VOC [g/h]	51.92	279.06	53.66	11.98	243.93	33.69	21.72	9.01	22.47	58.67	12.27	10.87

**Other Modes**

g_Walk,mi, Effective Walk Time [s]	8.0			8.0			8.0			8.0		
M_corner, Corner Circulation Area [ft <sup>2</sup> /ped]	0.00			0.00			0.00			0.00		
M_CW, Crosswalk Circulation Area [ft <sup>2</sup> /ped]	0.00			0.00			0.00			0.00		
d_p, Pedestrian Delay [s]	26.99			26.99			26.99			26.99		
I_p,int, Pedestrian LOS Score for Intersectio	3.182			3.154			2.651			2.394		
Crosswalk LOS	C			C			B			B		
s_b, Saturation Flow Rate of the bicycle lane	2000			2000			2000			2000		
c_b, Capacity of the bicycle lane [bicycles/h]	869			869			869			869		
d_b, Bicycle Delay [s]	11.04			11.05			11.04			11.04		
I_b,int, Bicycle LOS Score for Intersection	2.246			2.092			2.018			2.007		
Bicycle LOS	B			B			B			B		

**Sequence**

Ring 1	1	2	3	4	-	-	-	-	-	-	-	-	-	-	-
Ring 2	5	6	7	8	-	-	-	-	-	-	-	-	-	-	-
Ring 3	-	-	-	-	-	-	-	-	-	-	-	-	-	-	-
Ring 4	-	-	-	-	-	-	-	-	-	-	-	-	-	-	-

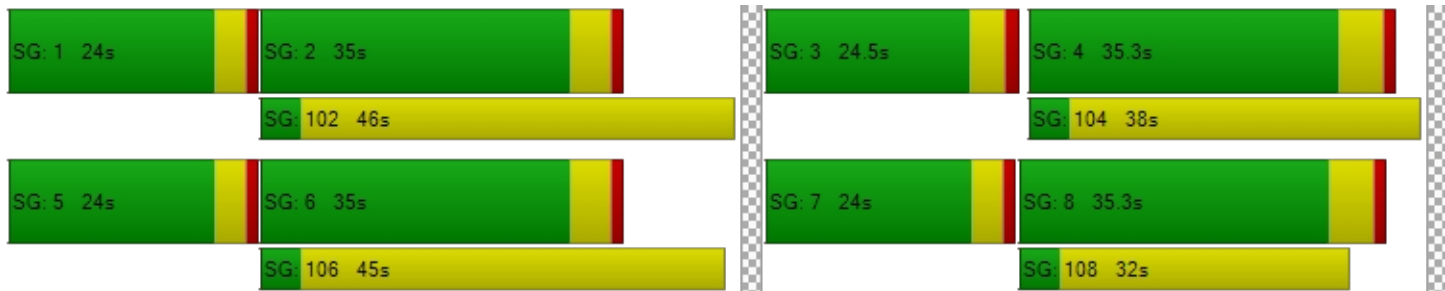

**Intersection Level Of Service Report**  
**Intersection 9: Fallon Road & Dublin Boulevard**

Control Type:	Signalized	Delay (sec / veh):	21.4
Analysis Method:	HCM 7th Edition	Level Of Service:	C
Analysis Period:	15 minutes	Volume to Capacity (v/c):	0.484

**Intersection Setup**

Name	Fallon Road			Fallon Road			Dublin Boulevard			Dublin Boulevard		
Approach	Northbound			Southbound			Eastbound			Westbound		
Lane Configuration	[Diagram]			[Diagram]			[Diagram]			[Diagram]		
Turning Movement	Left	Thru	Right	Left	Thru	Right	Left	Thru	Right	Left	Thru	Right
Lane Width [ft]	12.00	12.00	12.00	12.00	12.00	12.00	12.00	12.00	12.00	12.00	12.00	12.00
No. of Lanes in Entry Pocket	2	0	0	1	0	1	1	0	1	0	0	0
Entry Pocket Length [ft]	430.00	100.00	100.00	140.00	100.00	225.00	400.00	100.00	400.00	100.00	100.00	100.00
No. of Lanes in Exit Pocket	0	0	0	0	0	0	0	0	1	0	0	0
Exit Pocket Length [ft]	0.00	0.00	0.00	0.00	0.00	0.00	0.00	0.00	500.00	0.00	0.00	0.00
Speed [mph]	45.00			45.00			45.00			45.00		
Grade [%]	0.00			0.00			0.00			0.00		
Curb Present	Yes			Yes			Yes			Yes		
Crosswalk	No			No			Yes			Yes		



**Volumes**

Name	Fallon Road			Fallon Road			Dublin Boulevard			Dublin Boulevard		
Base Volume Input [veh/h]	164	903	0	0	923	128	222	0	372	0	0	0
Base Volume Adjustment Factor	1.0000	1.0000	1.0000	1.0000	1.0000	1.0000	1.0000	1.0000	1.0000	1.0000	1.0000	1.0000
Heavy Vehicles Percentage [%]	3.70	0.30	4.00	1.00	0.70	1.60	0.00	4.00	2.20	1.00	1.00	1.00
Proportion of CAVs [%]	0.00											
Growth Factor	1.0000	1.0000	1.0000	1.0000	1.0000	1.0000	1.0000	1.0000	1.0000	1.0000	1.0000	1.0000
In-Process Volume [veh/h]	0	0	0	0	0	0	0	0	0	0	0	0
Site-Generated Trips [veh/h]	0	0	0	0	0	0	0	0	0	0	0	0
Diverted Trips [veh/h]	0	0	0	0	0	0	0	0	0	0	0	0
Pass-by Trips [veh/h]	0	0	0	0	0	0	0	0	0	0	0	0
Existing Site Adjustment Volume [veh/h]	0	0	0	0	0	0	0	0	0	0	0	0
Other Volume [veh/h]	0	0	0	0	0	0	0	0	0	0	0	0
Right Turn on Red Volume [veh/h]	0	0	0	0	0	0	0	0	0	0	0	0
Total Hourly Volume [veh/h]	164	903	0	0	923	128	222	0	372	0	0	0
Peak Hour Factor	0.9400	0.9400	0.9400	0.9400	0.9400	0.9400	0.9400	0.9400	0.9400	0.9400	0.9400	0.9400
Other Adjustment Factor	1.0000	1.0000	1.0000	1.0000	1.0000	1.0000	1.0000	1.0000	1.0000	1.0000	1.0000	1.0000
Total 15-Minute Volume [veh/h]	44	240	0	0	245	34	59	0	99	0	0	0
Total Analysis Volume [veh/h]	174	961	0	0	982	136	236	0	396	0	0	0
Presence of On-Street Parking	No		No	No		No	No		No	No		No
On-Street Parking Maneuver Rate [/h]	0	0	0	0	0	0	0	0	0	0	0	0
Local Bus Stopping Rate [/h]	0	0	0	0	0	0	0	0	0	0	0	0
v_do, Outbound Pedestrian Volume crossing	0			0			0			0		
v_di, Inbound Pedestrian Volume crossing m	0			0			0			0		
v_co, Outbound Pedestrian Volume crossing	0			2			3			0		
v_ci, Inbound Pedestrian Volume crossing mi	0			3			2			0		
v_ab, Corner Pedestrian Volume [ped/h]	0			0			0			0		
Bicycle Volume [bicycles/h]	0			1			0			0		



**Intersection Settings**

Located in CBD	No
Signal Coordination Group	-
Cycle Length [s]	140
Active Pattern	Pattern 1
Coordination Type	Time of Day Pattern Isolated
Actuation Type	Fully actuated
Offset [s]	0.0
Offset Reference	Lead Green - Beginning of First Green
Permissive Mode	SingleBand
Lost time [s]	12.00

**Phasing & Timing (Basic)**

Control Type	Protecte	Permiss	Permiss	Protecte	Permiss	Permiss	Protecte	Permiss	Overlap	Protecte	Permiss	Permiss
Signal Group	3	8	0	7	4	0	5	2	2	1	6	0
Auxiliary Signal Groups									2,3			
Maximum Green [s]	30	30	0	12	30	0	30	30	30	12	12	0
Amber [s]	4.3	4.7	0.0	4.3	4.7	0.0	4.3	4.3	4.3	3.0	4.8	0.0
All red [s]	1.0	1.0	0.0	1.0	1.0	0.0	1.0	1.0	1.0	1.0	1.0	0.0
Walk [s]	0	0	0	0	4	0	0	0	0	0	0	0
Pedestrian Clearance [s]	0	0	0	0	41	0	0	0	0	0	0	0
Delayed Vehicle Green [s]	0.0	0.0	0.0	0.0	0.0	0.0	0.0	0.0	0.0	0.0	0.0	0.0
Rest In Walk		No			No			No			No	
I1, Start-Up Lost Time [s]	2.0	2.0	0.0	2.0	2.0	0.0	2.0	2.0	2.0	2.0	2.0	0.0
I2, Clearance Lost Time [s]	2.0	2.0	0.0	2.0	2.0	0.0	2.0	2.0	2.0	2.0	2.0	0.0
Detector Location [ft]	0.0	0.0	0.0	0.0	0.0	0.0	0.0	0.0	0.0	0.0	0.0	0.0
Detector Length [ft]	20.0	20.0	0.0	20.0	20.0	0.0	0.0	0.0	0.0	20.0	20.0	0.0
I, Upstream Filtering Factor	1.00	1.00	1.00	1.00	1.00	1.00	1.00	1.00	1.00	1.00	1.00	1.00

**Phasing & Timing: Pattern 1**

Split [s]	35	65	0	20	50	0	35	35	35	20	20	0
Lead / Lag	Lead	-	-	Lead	-	-	Lead	-	-	Lead	-	-
Minimum Green [s]	10	12	0	10	12	0	10	12	12	10	10	0
Vehicle Extension [s]	2.0	4.0	0.0	2.0	4.0	0.0	2.0	4.0	4.0	2.0	2.0	0.0
Minimum Recall	No	Yes		No	Yes		No	No	No	No	No	
Maximum Recall	No	No		No	No		No	No	No	No	No	
Pedestrian Recall	No	No		No	No		No	No	No	No	No	

**Exclusive Pedestrian Phase**

Pedestrian Signal Group	0
Pedestrian Walk [s]	0
Pedestrian Clearance [s]	0



**Lane Group Calculations**

Lane Group	L	C	C	L	C	R	L	C	R	L	C
C, Cycle Length [s]	140	140	140	140	140	140	140	140	140	140	140
L, Total Lost Time per Cycle [s]	4.00	4.00	4.00	4.00	4.00	4.00	4.00	4.00	4.00	4.00	4.00
l1_p, Permitted Start-Up Lost Time [s]	0.00	0.00	0.00	0.00	0.00	0.00	0.00	0.00	0.00	0.00	0.00
l2, Clearance Lost Time [s]	2.00	2.00	2.00	2.00	2.00	2.00	2.00	2.00	0.00	2.00	2.00
g_i, Effective Green Time [s]	22	108	108	1	87	87	13	15	41	0	2
g / C, Green / Cycle	0.16	0.77	0.77	0.01	0.62	0.62	0.09	0.10	0.29	0.00	0.01
(v / s)_i Volume / Saturation Flow Rate	0.05	0.25	0.25	0.00	0.27	0.09	0.07	0.00	0.14	0.00	0.00
s, saturation flow rate [veh/h]	3411	1895	1895	1795	3598	1571	3514	1840	2809	1795	1885
c, Capacity [veh/h]	535	1464	1464	17	2247	981	320	191	787	0	25
d1, Uniform Delay [s]	52.42	4.87	4.87	0.00	13.56	10.78	61.98	0.00	42.22	0.00	0.00
k, delay calibration	0.04	0.50	0.50	0.04	0.50	0.50	0.04	0.15	0.15	0.04	0.04
l, Upstream Filtering Factor	1.00	1.00	1.00	1.00	1.00	1.00	1.00	1.00	1.00	1.00	1.00
d2, Incremental Delay [s]	0.13	0.60	0.60	0.00	0.62	0.29	1.26	0.00	0.71	0.00	0.00
d3, Initial Queue Delay [s]	0.00	0.00	0.00	0.00	0.00	0.00	0.00	0.00	0.00	0.00	0.00
Rp, platoon ratio	1.00	1.00	1.00	1.00	1.00	1.00	1.00	1.00	1.00	1.00	1.00
PF, progression factor	1.00	1.00	1.00	1.00	1.00	1.00	1.00	1.00	1.00	1.00	1.00

**Lane Group Results**

X, volume / capacity	0.33	0.33	0.33	0.00	0.44	0.14	0.74	0.00	0.50	0.00	0.00
d, Delay for Lane Group [s/veh]	52.55	5.47	5.47	0.00	14.18	11.07	63.24	0.00	42.93	0.00	0.00
Lane Group LOS	D	A	A	A	B	B	E	A	D	A	A
Critical Lane Group	Yes	No	No	No	Yes	No	No	No	Yes	No	No
50th-Percentile Queue Length [veh/ln]	2.69	3.65	3.65	0.00	7.64	1.72	4.08	0.00	5.71	0.00	0.00
50th-Percentile Queue Length [ft/ln]	67.19	91.16	91.16	0.00	191.03	43.00	101.90	0.00	142.69	0.00	0.00
95th-Percentile Queue Length [veh/ln]	4.84	6.56	6.56	0.00	12.17	3.10	7.34	0.00	9.63	0.00	0.00
95th-Percentile Queue Length [ft/ln]	120.95	164.08	164.08	0.00	304.36	77.40	183.42	0.00	240.64	0.00	0.00



**Movement, Approach, & Intersection Results**

d_M, Delay for Movement [s/veh]	52.55	5.47	5.47	0.00	14.18	11.07	63.24	0.00	42.93	0.00	0.00	0.00
Movement LOS	D	A	A	A	B	B	E	A	D	A	A	A
d_A, Approach Delay [s/veh]	12.68			13.80			50.51			0.00		
Approach LOS	B			B			D			A		
d_I, Intersection Delay [s/veh]	21.40											
Intersection LOS	C											
Intersection V/C	0.484											

**Emissions**

Vehicle Miles Traveled [mph]	23.37	64.53	64.53	0.00	260.01	36.01	283.94	0.00	476.45	0.00	0.00
Stops [stops/h]	138.24	93.77	93.77	0.00	393.02	44.23	209.64	0.00	293.56	0.00	0.00
Fuel consumption [US gal/h]	4.38	3.91	3.91	0.00	16.63	2.09	15.38	0.00	23.44	0.00	0.00
CO [g/h]	306.18	273.49	273.49	0.00	1162.62	146.14	1074.80	0.00	1638.51	0.00	0.00
NOx [g/h]	59.57	53.21	53.21	0.00	226.20	28.43	209.12	0.00	318.79	0.00	0.00
VOC [g/h]	70.96	63.38	63.38	0.00	269.45	33.87	249.10	0.00	379.74	0.00	0.00

**Other Modes**

g_Walk,mi, Effective Walk Time [s]	0.0			0.0			8.0			59.3		
M_corner, Corner Circulation Area [ft <sup>2</sup> /ped]	0.00			0.00			0.00			0.00		
M_CW, Crosswalk Circulation Area [ft <sup>2</sup> /ped]	0.00			0.00			787.71			0.00		
d_p, Pedestrian Delay [s]	0.00			0.00			62.22			23.25		
I_p,int, Pedestrian LOS Score for Intersectio	0.000			0.000			2.921			2.115		
Crosswalk LOS	F			F			C			B		
s_b, Saturation Flow Rate of the bicycle lane	2000			2000			2000			2000		
c_b, Capacity of the bicycle lane [bicycles/h]	847			633			424			203		
d_b, Bicycle Delay [s]	23.25			32.72			43.44			56.51		
I_b,int, Bicycle LOS Score for Intersection	2.496			2.482			2.602			1.560		
Bicycle LOS	B			B			B			A		

**Sequence**

Ring 1	1	2	3	4	-	-	-	-	-	-	-	-	-	-	-
Ring 2	5	6	7	8	-	-	-	-	-	-	-	-	-	-	-
Ring 3	-	-	-	-	-	-	-	-	-	-	-	-	-	-	-
Ring 4	-	-	-	-	-	-	-	-	-	-	-	-	-	-	-





**Intersection Level Of Service Report**  
**Intersection 10: Fallon Road & Fallon Gateway**

Control Type:	Signalized	Delay (sec / veh):	13.0
Analysis Method:	HCM 7th Edition	Level Of Service:	B
Analysis Period:	15 minutes	Volume to Capacity (v/c):	0.589

**Intersection Setup**

Name	Fallon Road		Fallon Road		Fallon Gateway	
Approach	Northbound		Southbound		Eastbound	
Lane Configuration	↵↵		↵		↵↵↵↵	
Turning Movement	Left	Thru	Thru	Right	Left	Right
Lane Width [ft]	12.00	12.00	12.00	12.00	12.00	12.00
No. of Lanes in Entry Pocket	1	0	0	0	1	1
Entry Pocket Length [ft]	275.00	100.00	100.00	100.00	210.00	210.00
No. of Lanes in Exit Pocket	0	0	0	0	0	0
Exit Pocket Length [ft]	0.00	0.00	0.00	0.00	0.00	0.00
Speed [mph]	45.00		40.00		25.00	
Grade [%]	0.00		0.00		0.00	
Curb Present	Yes		Yes		Yes	
Crosswalk	No		No		Yes	



**Volumes**

Name	Fallon Road		Fallon Road		Fallon Gateway	
Base Volume Input [veh/h]	308	1001	980	102	62	304
Base Volume Adjustment Factor	1.0000	1.0000	1.0000	1.0000	1.0000	1.0000
Heavy Vehicles Percentage [%]	1.00	0.60	1.30	1.00	0.00	1.30
Proportion of CAVs [%]	0.00					
Growth Factor	1.0000	1.0000	1.0000	1.0000	1.0000	1.0000
In-Process Volume [veh/h]	0	0	0	0	0	0
Site-Generated Trips [veh/h]	0	0	0	0	0	0
Diverted Trips [veh/h]	0	0	0	0	0	0
Pass-by Trips [veh/h]	0	0	0	0	0	0
Existing Site Adjustment Volume [veh/h]	0	0	0	0	0	0
Other Volume [veh/h]	0	0	0	0	0	0
Right Turn on Red Volume [veh/h]	0	0	0	0	0	0
Total Hourly Volume [veh/h]	308	1001	980	102	62	304
Peak Hour Factor	0.9400	0.9400	0.9400	0.9400	0.9400	0.9400
Other Adjustment Factor	1.0000	1.0000	1.0000	1.0000	1.0000	1.0000
Total 15-Minute Volume [veh/h]	82	266	261	27	16	81
Total Analysis Volume [veh/h]	328	1065	1043	109	66	323
Presence of On-Street Parking	No	No	No	No	No	No
On-Street Parking Maneuver Rate [/h]	0	0	0	0	0	0
Local Bus Stopping Rate [/h]	0	0	0	0	0	0
v_do, Outbound Pedestrian Volume crossing	0		0		0	
v_di, Inbound Pedestrian Volume crossing m	0		0		0	
v_co, Outbound Pedestrian Volume crossing	0		0		0	
v_ci, Inbound Pedestrian Volume crossing mi	0		0		0	
v_ab, Corner Pedestrian Volume [ped/h]	0		0		0	
Bicycle Volume [bicycles/h]	0		0		0	



**Intersection Settings**

Located in CBD	No
Signal Coordination Group	-
Cycle Length [s]	105
Active Pattern	Pattern 1
Coordination Type	Time of Day Pattern Isolated
Actuation Type	Fully actuated
Offset [s]	0.0
Offset Reference	Lead Green - Beginning of First Green
Permissive Mode	SingleBand
Lost time [s]	9.00

**Phasing & Timing (Basic)**

Control Type	Protected	Permissive	Permissive	Permissive	Permissive	Overlap
Signal Group	3	8	4	0	2	2
Auxiliary Signal Groups						2,3
Maximum Green [s]	20	40	40	0	30	30
Amber [s]	3.5	4.7	4.7	0.0	3.5	3.5
All red [s]	1.0	1.0	1.0	0.0	1.0	1.0
Walk [s]	0	0	4	0	0	0
Pedestrian Clearance [s]	0	0	28	0	0	0
Delayed Vehicle Green [s]	0.0	0.0	0.0	0.0	0.0	0.0
Rest In Walk		No	No		No	
I1, Start-Up Lost Time [s]	2.0	2.0	2.0	0.0	2.0	2.0
I2, Clearance Lost Time [s]	2.5	3.7	3.7	0.0	2.5	2.5
Detector Location [ft]	0.0	0.0	0.0	0.0	0.0	0.0
Detector Length [ft]	20.0	20.0	0.0	0.0	20.0	20.0
I, Upstream Filtering Factor	1.00	1.00	1.00	1.00	1.00	1.00

**Phasing & Timing: Pattern 1**

Split [s]	25	70	45	0	35	35
Lead / Lag	Lead	-	-	-	Lead	-
Minimum Green [s]	10	10	10	0	10	10
Vehicle Extension [s]	2.0	5.0	5.0	0.0	2.0	2.0
Minimum Recall	No	Yes	Yes		No	No
Maximum Recall	No	No	No		No	No
Pedestrian Recall	No	No	No		No	No

**Exclusive Pedestrian Phase**

Pedestrian Signal Group	0
Pedestrian Walk [s]	0
Pedestrian Clearance [s]	0



**Lane Group Calculations**

Lane Group	L	C	C	C	L	R
C, Cycle Length [s]	61	61	61	61	61	61
L, Total Lost Time per Cycle [s]	4.50	5.70	5.70	5.70	4.50	4.50
l1_p, Permitted Start-Up Lost Time [s]	0.00	0.00	0.00	0.00	0.00	0.00
l2, Clearance Lost Time [s]	2.50	3.70	3.70	3.70	2.50	0.00
g_i, Effective Green Time [s]	10	41	27	27	10	24
g / C, Green / Cycle	0.16	0.67	0.43	0.43	0.16	0.40
(v / s)_i Volume / Saturation Flow Rate	0.09	0.30	0.31	0.32	0.02	0.11
s, saturation flow rate [veh/h]	3486	3600	1880	1820	3514	2829
c, Capacity [veh/h]	567	2415	818	792	573	1128
d1, Uniform Delay [s]	23.76	4.72	14.13	14.34	21.91	12.52
k, delay calibration	0.04	0.23	0.23	0.23	0.04	0.04
l, Upstream Filtering Factor	1.00	1.00	1.00	1.00	1.00	1.00
d2, Incremental Delay [s]	0.35	0.27	2.38	2.75	0.03	0.05
d3, Initial Queue Delay [s]	0.00	0.00	0.00	0.00	0.00	0.00
Rp, platoon ratio	1.00	1.00	1.00	1.00	1.00	1.00
PF, progression factor	1.00	1.00	1.00	1.00	1.00	1.00

**Lane Group Results**

X, volume / capacity	0.58	0.44	0.70	0.73	0.12	0.29
d, Delay for Lane Group [s/veh]	24.11	4.99	16.51	17.09	21.95	12.57
Lane Group LOS	C	A	B	B	C	B
Critical Lane Group	Yes	No	No	Yes	No	Yes
50th-Percentile Queue Length [veh/ln]	1.96	1.64	5.77	5.91	0.39	1.39
50th-Percentile Queue Length [ft/ln]	49.09	40.94	144.13	147.68	9.81	34.73
95th-Percentile Queue Length [veh/ln]	3.53	2.95	9.70	9.89	0.71	2.50
95th-Percentile Queue Length [ft/ln]	88.36	73.69	242.58	247.33	17.66	62.51

**Movement, Approach, & Intersection Results**

d_M, Delay for Movement [s/veh]	24.11	4.99	16.77	17.09	21.95	12.57
Movement LOS	C	A	B	B	C	B
d_A, Approach Delay [s/veh]	9.50		16.80		14.16	
Approach LOS	A		B		B	
d_I, Intersection Delay [s/veh]	12.98					
Intersection LOS	B					
Intersection V/C	0.589					

**Emissions**

Vehicle Miles Traveled [mph]	49.90	162.03	77.36	77.36	4.05	19.82
Stops [stops/h]	230.62	192.33	338.55	346.88	46.10	163.13
Fuel consumption [US gal/h]	6.19	9.03	8.03	8.18	0.65	2.34
CO [g/h]	432.50	631.06	561.43	571.90	45.69	163.80
NOx [g/h]	84.15	122.78	109.23	111.27	8.89	31.87
VOC [g/h]	100.24	146.25	130.12	132.54	10.59	37.96

**Other Modes**

g_Walk,mi, Effective Walk Time [s]	0.0		0.0		8.0	
M_corner, Corner Circulation Area [ft <sup>2</sup> /ped]	0.00		0.00		0.00	
M_CW, Crosswalk Circulation Area [ft <sup>2</sup> /ped]	0.00		0.00		0.00	
d_p, Pedestrian Delay [s]	0.00		0.00		23.18	
I_p,int, Pedestrian LOS Score for Intersectio	0.000		0.000		2.548	
Crosswalk LOS	F		F		B	
s_b, Saturation Flow Rate of the bicycle lane	2000		2000		2000	
c_b, Capacity of the bicycle lane [bicycles/h]	2098		1282		995	
d_b, Bicycle Delay [s]	0.07		3.95		7.74	
I_b,int, Bicycle LOS Score for Intersection	2.709		2.510		1.560	
Bicycle LOS	B		B		A	

**Sequence**

Ring 1	-	2	3	4	-	-	-	-	-	-	-	-	-	-	-	-
Ring 2	-	-	-	8	-	-	-	-	-	-	-	-	-	-	-	-
Ring 3	-	-	-	-	-	-	-	-	-	-	-	-	-	-	-	-
Ring 4	-	-	-	-	-	-	-	-	-	-	-	-	-	-	-	-

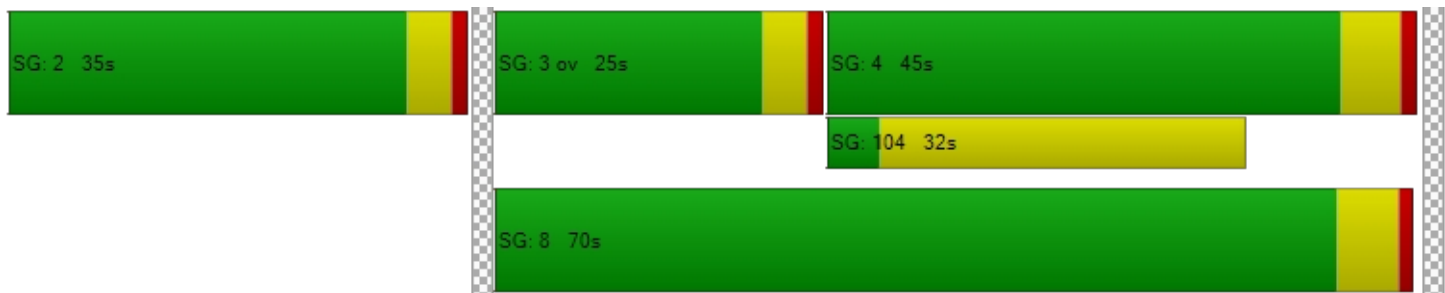

**Intersection Level Of Service Report**  
**Intersection 11: Fallon Road & I-580 WB Ramps**

Control Type:	Signalized	Delay (sec / veh):	17.1
Analysis Method:	HCM 7th Edition	Level Of Service:	B
Analysis Period:	15 minutes	Volume to Capacity (v/c):	0.535

**Intersection Setup**

Name	Fallon Road			Fallon Road			I-580 WB On-Ramp			I-580 WB Off-Ramp		
Approach	Northbound			Southbound			Eastbound			Westbound		
Lane Configuration	↑			↑↑↑						↑↑↑		
Turning Movement	Left	Thru	Right	Left	Thru	Right	Left	Thru	Right	Left	Thru	Right
Lane Width [ft]	12.00	12.00	12.00	12.00	12.00	12.00	12.00	12.00	12.00	12.00	12.00	12.00
No. of Lanes in Entry Pocket	0	0	0	0	0	1	0	0	0	1	0	1
Entry Pocket Length [ft]	100.00	100.00	100.00	100.00	100.00	225.00	100.00	100.00	100.00	170.00	100.00	130.00
No. of Lanes in Exit Pocket	0	0	1	0	0	0	0	0	1	0	0	0
Exit Pocket Length [ft]	0.00	0.00	400.00	0.00	0.00	0.00	0.00	0.00	400.00	0.00	0.00	0.00
Speed [mph]	45.00			40.00			30.00			35.00		
Grade [%]	0.00			0.00			0.00			0.00		
Curb Present	No			No						No		
Crosswalk	No			No			No			No		



**Volumes**

Name	Fallon Road			Fallon Road			I-580 WB On-Ramp			I-580 WB Off-Ramp		
	Base Volume Input [veh/h]	0	762	0	0	945	602	0	0	0	239	1
Base Volume Adjustment Factor	1.0000	1.0000	1.0000	1.0000	1.0000	1.0000	1.0000	1.0000	1.0000	1.0000	1.0000	1.0000
Heavy Vehicles Percentage [%]	2.00	0.10	2.00	2.00	0.60	1.00	2.00	2.00	2.00	0.80	0.00	1.50
Proportion of CAVs [%]	0.00											
Growth Factor	1.0000	1.0000	1.0000	1.0000	1.0000	1.0000	1.0000	1.0000	1.0000	1.0000	1.0000	1.0000
In-Process Volume [veh/h]	0	0	0	0	0	0	0	0	0	0	0	0
Site-Generated Trips [veh/h]	0	0	0	0	0	0	0	0	0	0	0	0
Diverted Trips [veh/h]	0	0	0	0	0	0	0	0	0	0	0	0
Pass-by Trips [veh/h]	0	0	0	0	0	0	0	0	0	0	0	0
Existing Site Adjustment Volume [veh/h]	0	0	0	0	0	0	0	0	0	0	0	0
Other Volume [veh/h]	0	0	0	0	0	0	0	0	0	0	0	0
Right Turn on Red Volume [veh/h]	0	0	0	0	0	0	0	0	0	0	0	0
Total Hourly Volume [veh/h]	0	762	0	0	945	602	0	0	0	239	1	590
Peak Hour Factor	1.0000	0.9500	1.0000	1.0000	0.9500	0.9500	1.0000	1.0000	1.0000	0.9500	0.9500	0.9500
Other Adjustment Factor	1.0000	1.0000	1.0000	1.0000	1.0000	1.0000	1.0000	1.0000	1.0000	1.0000	1.0000	1.0000
Total 15-Minute Volume [veh/h]	0	201	0	0	249	158	0	0	0	63	0	155
Total Analysis Volume [veh/h]	0	802	0	0	995	634	0	0	0	252	1	621
Presence of On-Street Parking	No		No	No		No				No		No
On-Street Parking Maneuver Rate [/h]	0	0	0	0	0	0	0	0	0	0	0	0
Local Bus Stopping Rate [/h]	0	0	0	0	0	0	0	0	0	0	0	0
v_do, Outbound Pedestrian Volume crossing	0			0			0			0		
v_di, Inbound Pedestrian Volume crossing m	0			0			0			0		
v_co, Outbound Pedestrian Volume crossing	0			0			0			0		
v_ci, Inbound Pedestrian Volume crossing mi	0			0			0			0		
v_ab, Corner Pedestrian Volume [ped/h]	0			0			0			0		
Bicycle Volume [bicycles/h]	0			0			0			0		



**Intersection Settings**

Located in CBD	No
Signal Coordination Group	-
Cycle Length [s]	90
Active Pattern	Free Running (No Pattern)
Coordination Type	<i>Free Running</i>
Actuation Type	<i>Fully actuated</i>
Offset [s]	0.0
Offset Reference	Lead Green - Beginning of First Green
Permissive Mode	SingleBand
Lost time [s]	9.00

**Phasing & Timing (Basic)**

Control Type	Permiss	Permiss	Permiss	Permiss	Permiss	Permiss	Permiss	Permiss	Permiss	Permiss	Permiss	Overlap
Signal Group	0	2	0	0	6	0	0	0	0	0	8	1
Auxiliary Signal Groups												1,8
Maximum Green [s]	0	35	0	0	35	0	0	0	0	0	20	15
Amber [s]	0.0	4.8	0.0	0.0	4.8	0.0	0.0	0.0	0.0	0.0	3.7	3.7
All red [s]	0.0	0.5	0.0	0.0	0.5	0.0	0.0	0.0	0.0	0.0	0.5	0.5
Walk [s]	0	0	0	0	0	0	0	0	0	0	0	0
Pedestrian Clearance [s]	0	0	0	0	0	0	0	0	0	0	0	0
Delayed Vehicle Green [s]	0.0	0.0	0.0	0.0	0.0	0.0	0.0	0.0	0.0	0.0	0.0	0.0
Rest In Walk		No			No						No	
I1, Start-Up Lost Time [s]	0.0	2.0	0.0	0.0	2.0	0.0	0.0	0.0	0.0	0.0	2.0	2.0
I2, Clearance Lost Time [s]	0.0	3.3	0.0	0.0	3.3	0.0	0.0	0.0	0.0	0.0	2.2	2.2
Detector Location [ft]	0.0	0.0	0.0	0.0	0.0	0.0	0.0	0.0	0.0	0.0	0.0	0.0
Detector Length [ft]	0.0	20.0	0.0	0.0	20.0	0.0	0.0	0.0	0.0	0.0	20.0	20.0
I, Upstream Filtering Factor	1.00	1.00	1.00	1.00	1.00	1.00	1.00	1.00	1.00	1.00	1.00	1.00

**Phasing & Timing: Free Running (No Pattern)**

Split [s]	0	0	0	0	0	0	0	0	0	0	0	0
Lead / Lag	-	-	-	-	-	-	-	-	-	-	-	-
Minimum Green [s]	0	10	0	0	10	0	0	0	0	0	5	4
Vehicle Extension [s]	0.0	0.0	0.0	0.0	0.0	0.0	0.0	0.0	0.0	0.0	0.0	0.0
Minimum Recall		Yes			Yes						No	No
Maximum Recall		No			No						No	No
Pedestrian Recall		No			No						No	No

**Exclusive Pedestrian Phase**

Pedestrian Signal Group	0
Pedestrian Walk [s]	0
Pedestrian Clearance [s]	0





**Lane Group Calculations**

Lane Group	C	C	R		L	C	R
C, Cycle Length [s]	74	74	74		74	74	74
L, Total Lost Time per Cycle [s]	5.30	5.30	5.30		4.20	4.20	4.20
l1_p, Permitted Start-Up Lost Time [s]	0.00	0.00	0.00		0.00	0.00	0.00
l2, Clearance Lost Time [s]	3.30	3.30	3.30		2.20	2.20	0.00
g_i, Effective Green Time [s]	32	50	50		14	14	32
g / C, Green / Cycle	0.44	0.68	0.68		0.19	0.19	0.43
(v / s)_i Volume / Saturation Flow Rate	0.42	0.28	0.40		0.07	0.07	0.22
s, saturation flow rate [veh/h]	1898	3600	1602		1798	1810	2825
c, Capacity [veh/h]	834	2462	1095		338	340	1222
d1, Uniform Delay [s]	20.14	5.11	6.12		26.23	26.23	15.27
k, delay calibration	0.33	0.04	0.28		0.04	0.04	0.04
l, Upstream Filtering Factor	1.00	1.00	1.00		1.00	1.00	1.00
d2, Incremental Delay [s]	17.75	0.04	1.27		0.25	0.25	0.12
d3, Initial Queue Delay [s]	0.00	0.00	0.00		0.00	0.00	0.00
Rp, platoon ratio	1.00	1.00	1.00		1.00	1.00	1.00
PF, progression factor	1.00	1.00	1.00		1.00	1.00	1.00

**Lane Group Results**

X, volume / capacity	0.96	0.40	0.58		0.37	0.37	0.51
d, Delay for Lane Group [s/veh]	37.89	5.15	7.39		26.48	26.48	15.39
Lane Group LOS	D	A	A		C	C	B
Critical Lane Group	Yes	No	No		No	No	Yes
50th-Percentile Queue Length [veh/ln]	15.14	2.18	3.69		1.86	1.87	3.42
50th-Percentile Queue Length [ft/ln]	378.40	54.51	92.32		46.51	46.81	85.38
95th-Percentile Queue Length [veh/ln]	21.52	3.92	6.65		3.35	3.37	6.15
95th-Percentile Queue Length [ft/ln]	537.91	98.12	166.18		83.73	84.26	153.69



**Movement, Approach, & Intersection Results**

d_M, Delay for Movement [s/veh]	0.00	37.89	0.00	0.00	5.15	7.39	0.00	0.00	0.00	26.48	26.48	15.39
Movement LOS		D			A	A				C	C	B
d_A, Approach Delay [s/veh]	37.89		6.02			0.00			18.60			
Approach LOS	D		A			A			B			
d_I, Intersection Delay [s/veh]	17.08											
Intersection LOS	B											
Intersection V/C	0.535											

**Emissions**

Vehicle Miles Traveled [mph]	83.59	151.38	96.46	18.29	18.41	90.09
Stops [stops/h]	738.08	212.66	180.08	90.73	91.31	333.09
Fuel consumption [US gal/h]	18.23	8.56	6.18	2.06	2.07	7.88
CO [g/h]	1273.96	598.00	431.84	143.93	144.85	551.08
NOx [g/h]	247.87	116.35	84.02	28.00	28.18	107.22
VOC [g/h]	295.25	138.59	100.08	33.36	33.57	127.72

**Other Modes**

g_Walk,mi, Effective Walk Time [s]	0.0	0.0	0.0	0.0
M_corner, Corner Circulation Area [ft <sup>2</sup> /ped]	0.00	0.00	0.00	0.00
M_CW, Crosswalk Circulation Area [ft <sup>2</sup> /ped]	0.00	0.00	0.00	0.00
d_p, Pedestrian Delay [s]	0.00	0.00	0.00	0.00
I_p,int, Pedestrian LOS Score for Intersectio	0.000	0.000	0.000	0.000
Crosswalk LOS	F	F	F	F
s_b, Saturation Flow Rate of the bicycle lane	2000	2000	2000	2000
c_b, Capacity of the bicycle lane [bicycles/h]	948	948	0	542
d_b, Bicycle Delay [s]	10.21	10.21	36.91	19.62
I_b,int, Bicycle LOS Score for Intersection	2.883	2.904	4.132	3.002
Bicycle LOS	C	C	D	C

**Sequence**

Ring 1	1	2	-	-	-	-	-	-	-	-	-	-	-	-	-
Ring 2	-	6	-	8	-	-	-	-	-	-	-	-	-	-	-
Ring 3	-	-	-	-	-	-	-	-	-	-	-	-	-	-	-
Ring 4	-	-	-	-	-	-	-	-	-	-	-	-	-	-	-



**Intersection Level Of Service Report**  
**Intersection 12: El Charro Road & I-580 EB Ramps**

Control Type:	Signalized	Delay (sec / veh):	6.9
Analysis Method:	HCM 7th Edition	Level Of Service:	A
Analysis Period:	15 minutes	Volume to Capacity (v/c):	0.544

**Intersection Setup**

Name	El Charro Road			Fallon Road			I-580 EB Off-Ramp			I-580 EB On-Ramp		
Approach	Northbound			Southbound			Eastbound			Westbound		
Lane Configuration	↑↑			↑↑			↵↵↵↵					
Turning Movement	Left	Thru	Right	Left	Thru	Right	Left	Thru	Right	Left	Thru	Right
Lane Width [ft]	12.00	12.00	12.00	12.00	12.00	12.00	12.00	12.00	12.00	12.00	12.00	12.00
No. of Lanes in Entry Pocket	0	0	0	1	0	0	1	0	1	0	0	0
Entry Pocket Length [ft]	100.00	100.00	100.00	135.00	100.00	100.00	350.00	100.00	350.00	100.00	100.00	100.00
No. of Lanes in Exit Pocket	0	0	0	0	0	1	0	0	0	0	0	0
Exit Pocket Length [ft]	0.00	0.00	0.00	0.00	0.00	100.00	0.00	0.00	0.00	0.00	0.00	0.00
Speed [mph]	30.00			40.00			35.00			30.00		
Grade [%]	0.00			0.00			0.00			0.00		
Curb Present	No			No			No					
Crosswalk	No			No			No			Yes		



**Volumes**

Name	El Charro Road			Fallon Road			I-580 EB Off-Ramp			I-580 EB On-Ramp		
Base Volume Input [veh/h]	0	779	0	0	677	0	381	0	328	0	0	0
Base Volume Adjustment Factor	1.0000	1.0000	1.0000	1.0000	1.0000	1.0000	1.0000	1.0000	1.0000	1.0000	1.0000	1.0000
Heavy Vehicles Percentage [%]	2.00	0.80	2.00	2.00	0.40	2.00	0.30	2.00	1.80	2.00	2.00	2.00
Proportion of CAVs [%]	0.00											
Growth Factor	1.0000	1.0000	1.0000	1.0000	1.0000	1.0000	1.0000	1.0000	1.0000	1.0000	1.0000	1.0000
In-Process Volume [veh/h]	0	0	0	0	0	0	0	0	0	0	0	0
Site-Generated Trips [veh/h]	0	0	0	0	0	0	0	0	0	0	0	0
Diverted Trips [veh/h]	0	0	0	0	0	0	0	0	0	0	0	0
Pass-by Trips [veh/h]	0	0	0	0	0	0	0	0	0	0	0	0
Existing Site Adjustment Volume [veh/h]	0	0	0	0	0	0	0	0	0	0	0	0
Other Volume [veh/h]	0	0	0	0	0	0	0	0	0	0	0	0
Right Turn on Red Volume [veh/h]	0	0	0	0	0	0	0	0	0	0	0	0
Total Hourly Volume [veh/h]	0	779	0	0	677	0	381	0	328	0	0	0
Peak Hour Factor	1.0000	0.9600	1.0000	1.0000	0.9600	1.0000	0.9600	1.0000	0.9600	1.0000	1.0000	1.0000
Other Adjustment Factor	1.0000	1.0000	1.0000	1.0000	1.0000	1.0000	1.0000	1.0000	1.0000	1.0000	1.0000	1.0000
Total 15-Minute Volume [veh/h]	0	203	0	0	176	0	99	0	85	0	0	0
Total Analysis Volume [veh/h]	0	811	0	0	705	0	397	0	342	0	0	0
Presence of On-Street Parking	No		No	No		No	No		No			
On-Street Parking Maneuver Rate [/h]	0	0	0	0	0	0	0	0	0	0	0	0
Local Bus Stopping Rate [/h]	0	0	0	0	0	0	0	0	0	0	0	0
v_do, Outbound Pedestrian Volume crossing	0			0			0			0		
v_di, Inbound Pedestrian Volume crossing m	0			0			0			0		
v_co, Outbound Pedestrian Volume crossing	0			0			0			0		
v_ci, Inbound Pedestrian Volume crossing mi	0			0			0			0		
v_ab, Corner Pedestrian Volume [ped/h]	0			0			0			0		
Bicycle Volume [bicycles/h]	0			0			0			0		



**Intersection Settings**

Located in CBD	No
Signal Coordination Group	-
Cycle Length [s]	90
Active Pattern	Free Running (No Pattern)
Coordination Type	<i>Free Running</i>
Actuation Type	<i>Fully actuated</i>
Offset [s]	0.0
Offset Reference	Lead Green - Beginning of First Green
Permissive Mode	SingleBand
Lost time [s]	9.00

**Phasing & Timing (Basic)**

Control Type	Permiss	Permiss	Permiss	Permiss	Permiss	Permiss	Permiss	Permiss	Permiss	Permiss	Permiss	Permiss
Signal Group	0	2	0	0	6	0	4	0	0	0	0	0
Auxiliary Signal Groups												
Maximum Green [s]	0	40	0	0	40	0	26	0	0	0	0	0
Amber [s]	0.0	4.8	0.0	0.0	4.8	0.0	3.7	0.0	0.0	0.0	0.0	0.0
All red [s]	0.0	1.0	0.0	0.0	1.0	0.0	0.5	0.0	0.0	0.0	0.0	0.0
Walk [s]	0	0	0	0	0	0	0	0	0	0	0	0
Pedestrian Clearance [s]	0	0	0	0	0	0	0	0	0	0	0	0
Delayed Vehicle Green [s]	0.0	0.0	0.0	0.0	0.0	0.0	0.0	0.0	0.0	0.0	0.0	0.0
Rest In Walk		No			No		No					
I1, Start-Up Lost Time [s]	0.0	2.0	0.0	0.0	2.0	0.0	2.0	0.0	0.0	0.0	0.0	0.0
I2, Clearance Lost Time [s]	0.0	3.3	0.0	0.0	3.3	0.0	2.7	0.0	0.0	0.0	0.0	0.0
Detector Location [ft]	0.0	0.0	0.0	0.0	0.0	0.0	0.0	0.0	0.0	0.0	0.0	0.0
Detector Length [ft]	0.0	0.0	0.0	0.0	0.0	0.0	0.0	0.0	0.0	0.0	0.0	0.0
I, Upstream Filtering Factor	1.00	1.00	1.00	1.00	1.00	1.00	1.00	1.00	1.00	1.00	1.00	1.00

**Phasing & Timing: Free Running (No Pattern)**

Split [s]	0	0	0	0	0	0	0	0	0	0	0	0
Lead / Lag	-	-	-	-	-	-	Lead	-	-	-	-	-
Minimum Green [s]	0	10	0	0	10	0	4	0	0	0	0	0
Vehicle Extension [s]	0.0	0.0	0.0	0.0	0.0	0.0	0.0	0.0	0.0	0.0	0.0	0.0
Minimum Recall		Yes			Yes		No					
Maximum Recall		No			No		No					
Pedestrian Recall		No			No		No					

**Exclusive Pedestrian Phase**

Pedestrian Signal Group	0
Pedestrian Walk [s]	0
Pedestrian Clearance [s]	0



**Lane Group Calculations**

Lane Group	C	C	L	R	
C, Cycle Length [s]	25	25	25	25	
L, Total Lost Time per Cycle [s]	5.30	5.30	4.70	4.70	
l1_p, Permitted Start-Up Lost Time [s]	0.00	0.00	0.00	0.00	
l2, Clearance Lost Time [s]	3.30	3.30	2.70	2.70	
g_i, Effective Green Time [s]	11	11	4	4	
g / C, Green / Cycle	0.42	0.42	0.18	0.18	
(v / s)_i Volume / Saturation Flow Rate	0.23	0.20	0.11	0.12	
s, saturation flow rate [veh/h]	3595	3606	3506	2818	
c, Capacity [veh/h]	1517	1522	623	501	
d1, Uniform Delay [s]	5.39	5.19	9.53	9.61	
k, delay calibration	0.04	0.04	0.04	0.04	
l, Upstream Filtering Factor	1.00	1.00	1.00	1.00	
d2, Incremental Delay [s]	0.11	0.08	0.41	0.62	
d3, Initial Queue Delay [s]	0.00	0.00	0.00	0.00	
Rp, platoon ratio	1.00	1.00	1.00	1.00	
PF, progression factor	1.00	1.00	1.00	1.00	

**Lane Group Results**

X, volume / capacity	0.53	0.46	0.64	0.68	
d, Delay for Lane Group [s/veh]	5.50	5.27	9.93	10.23	
Lane Group LOS	A	A	A	B	
Critical Lane Group	Yes	No	No	Yes	
50th-Percentile Queue Length [veh/ln]	0.60	0.30	0.61	0.55	
50th-Percentile Queue Length [ft/ln]	15.08	7.60	15.34	13.65	
95th-Percentile Queue Length [veh/ln]	1.09	0.55	1.10	0.98	
95th-Percentile Queue Length [ft/ln]	27.15	13.68	27.61	24.57	

**Movement, Approach, & Intersection Results**

d_M, Delay for Movement [s/veh]	0.00	5.50	0.00	0.00	5.27	0.00	9.93	0.00	10.23	0.00	0.00	0.00
Movement LOS		A			A		A		B			
d_A, Approach Delay [s/veh]	5.50				5.27		10.07		0.00			
Approach LOS	A				A		B		A			
d_I, Intersection Delay [s/veh]	6.92											
Intersection LOS	A											
Intersection V/C	0.544											

**Emissions**

Vehicle Miles Traveled [mph]	139.61	69.24	46.13	39.74
Stops [stops/h]	174.61	88.02	177.61	158.02
Fuel consumption [US gal/h]	7.62	4.10	3.90	3.42
CO [g/h]	532.59	286.64	272.37	238.73
NOx [g/h]	103.62	55.77	52.99	46.45
VOC [g/h]	123.43	66.43	63.12	55.33

**Other Modes**

g_Walk,mi, Effective Walk Time [s]	0.0	0.0	0.0	-5.8
M_corner, Corner Circulation Area [ft <sup>2</sup> /ped]	0.00	0.00	0.00	0.00
M_CW, Crosswalk Circulation Area [ft <sup>2</sup> /ped]	0.00	0.00	0.00	0.00
d_p, Pedestrian Delay [s]	0.00	0.00	0.00	18.91
I_p,int, Pedestrian LOS Score for Intersectio	0.000	0.000	0.000	1.690
Crosswalk LOS	F	F	F	A
s_b, Saturation Flow Rate of the bicycle lane	2000	2000	2000	2000
c_b, Capacity of the bicycle lane [bicycles/h]	3216	3216	2090	0
d_b, Bicycle Delay [s]	4.60	4.60	0.03	12.44
I_b,int, Bicycle LOS Score for Intersection	2.229	2.141	1.560	4.132
Bicycle LOS	B	B	A	D

**Sequence**

Ring 1	-	2	-	4	-	-	-	-	-	-	-	-	-	-	-	-
Ring 2	-	6	-	-	-	-	-	-	-	-	-	-	-	-	-	-
Ring 3	-	-	-	-	-	-	-	-	-	-	-	-	-	-	-	-
Ring 4	-	-	-	-	-	-	-	-	-	-	-	-	-	-	-	-



**Intersection Level Of Service Report**  
**Intersection 13: El Charro Road & Jack London Boulevard**

Control Type:	Signalized	Delay (sec / veh):	11.3
Analysis Method:	HCM 7th Edition	Level Of Service:	B
Analysis Period:	15 minutes	Volume to Capacity (v/c):	0.691

**Intersection Setup**

Name	El Charro Road			El Charro Road			Stoneridge Drive			Jack London Boulevard		
Approach	Northbound			Southbound			Eastbound			Westbound		
Lane Configuration	TUT			RTURT			TURT			TUT		
Turning Movement	Left	Thru	Right	Left	Thru	Right	Left	Thru	Right	Left	Thru	Right
Lane Width [ft]	12.00	12.00	12.00	12.00	12.00	12.00	12.00	12.00	12.00	12.00	12.00	12.00
No. of Lanes in Entry Pocket	1	0	2	2	0	1	3	0	1	1	0	2
Entry Pocket Length [ft]	125.00	100.00	175.00	650.00	100.00	450.00	450.00	100.00	325.00	400.00	100.00	775.00
No. of Lanes in Exit Pocket	0	0	0	0	0	2	1	0	0	0	0	0
Exit Pocket Length [ft]	0.00	0.00	0.00	0.00	0.00	100.00	450.00	0.00	0.00	0.00	0.00	0.00
Speed [mph]	30.00			30.00			30.00			30.00		
Grade [%]	0.00			0.00			0.00			0.00		
Curb Present	Yes			Yes			Yes			Yes		
Crosswalk	Yes			No			Yes			Yes		





**Volumes**

Name	El Charro Road			El Charro Road			Stoneridge Drive			Jack London Boulevard		
Base Volume Input [veh/h]	4	10	8	650	9	360	558	401	7	7	168	650
Base Volume Adjustment Factor	1.0000	1.0000	1.0000	1.0000	1.0000	1.0000	1.0000	1.0000	1.0000	1.0000	1.0000	1.0000
Heavy Vehicles Percentage [%]	0.00	20.00	0.00	0.30	44.40	0.80	0.50	0.50	0.00	0.00	1.80	0.60
Proportion of CAVs [%]	0.00											
Growth Factor	1.0000	1.0000	1.0000	1.0000	1.0000	1.0000	1.0000	1.0000	1.0000	1.0000	1.0000	1.0000
In-Process Volume [veh/h]	0	0	0	0	0	0	0	0	0	0	0	0
Site-Generated Trips [veh/h]	0	0	0	0	0	0	0	0	0	0	0	0
Diverted Trips [veh/h]	0	0	0	0	0	0	0	0	0	0	0	0
Pass-by Trips [veh/h]	0	0	0	0	0	0	0	0	0	0	0	0
Existing Site Adjustment Volume [veh/h]	0	0	0	0	0	0	0	0	0	0	0	0
Other Volume [veh/h]	0	0	0	0	0	0	0	0	0	0	0	0
Right Turn on Red Volume [veh/h]	0	0	0	0	0	0	0	0	0	0	0	0
Total Hourly Volume [veh/h]	4	10	8	650	9	360	558	401	7	7	168	650
Peak Hour Factor	0.9200	0.9200	0.9200	0.9200	0.9200	0.9200	0.9200	0.9200	0.9200	0.9200	0.9200	0.9200
Other Adjustment Factor	1.0000	1.0000	1.0000	1.0000	1.0000	1.0000	1.0000	1.0000	1.0000	1.0000	1.0000	1.0000
Total 15-Minute Volume [veh/h]	1	3	2	177	2	98	152	109	2	2	46	177
Total Analysis Volume [veh/h]	4	11	9	707	10	391	607	436	8	8	183	707
Presence of On-Street Parking	No		No	No		No	No		No	No		No
On-Street Parking Maneuver Rate [/h]	0	0	0	0	0	0	0	0	0	0	0	0
Local Bus Stopping Rate [/h]	0	0	0	0	0	0	0	0	0	0	0	0
v_do, Outbound Pedestrian Volume crossing	0			0			0			0		
v_di, Inbound Pedestrian Volume crossing m	0			0			0			0		
v_co, Outbound Pedestrian Volume crossing	0			0			0			0		
v_ci, Inbound Pedestrian Volume crossing mi	0			0			0			0		
v_ab, Corner Pedestrian Volume [ped/h]	0			0			0			0		
Bicycle Volume [bicycles/h]	0			0			0			0		



**Intersection Settings**

Located in CBD	No
Signal Coordination Group	-
Cycle Length [s]	90
Active Pattern	Free Running (No Pattern)
Coordination Type	<i>Free Running</i>
Actuation Type	<i>Fully actuated</i>
Offset [s]	0.0
Offset Reference	Lead Green - Beginning of First Green
Permissive Mode	SingleBand
Lost time [s]	12.00

**Phasing & Timing (Basic)**

Control Type	ProtPer	Permiss	Permiss	Protecte	Permiss	Permiss	ProtPer	Permiss	Permiss	ProtPer	Permiss	Overlap
Signal Group	7	4	0	3	8	0	1	6	0	5	2	2
Auxiliary Signal Groups												2,3
Maximum Green [s]	5	25	0	35	20	0	4	25	0	7	20	20
Amber [s]	3.0	5.0	0.0	3.0	4.3	0.0	3.0	4.3	0.0	3.0	4.3	4.3
All red [s]	1.0	1.0	0.0	1.0	1.0	0.0	1.0	1.0	0.0	1.0	1.0	1.0
Walk [s]	0	5	0	0	5	0	0	5	0	0	0	0
Pedestrian Clearance [s]	0	28	0	0	28	0	0	30	0	0	0	0
Delayed Vehicle Green [s]	0.0	0.0	0.0	0.0	0.0	0.0	0.0	0.0	0.0	0.0	0.0	0.0
Rest In Walk		No			No			No			No	
I1, Start-Up Lost Time [s]	2.0	2.0	0.0	2.0	2.0	0.0	2.0	2.0	0.0	2.0	2.0	2.0
I2, Clearance Lost Time [s]	2.0	2.0	0.0	2.0	2.0	0.0	2.0	2.0	0.0	2.0	2.0	2.0
Detector Location [ft]	0.0	0.0	0.0	0.0	0.0	0.0	0.0	0.0	0.0	0.0	0.0	0.0
Detector Length [ft]	0.0	0.0	0.0	0.0	0.0	0.0	0.0	0.0	0.0	0.0	0.0	0.0
I, Upstream Filtering Factor	1.00	1.00	1.00	1.00	1.00	1.00	1.00	1.00	1.00	1.00	1.00	1.00

**Phasing & Timing: Free Running (No Pattern)**

Split [s]	0	0	0	0	0	0	0	0	0	0	0	0
Lead / Lag	Lead	-	-	Lead	-	-	Lead	-	-	Lead	-	-
Minimum Green [s]	4	5	0	7	5	0	5	4	0	4	7	7
Vehicle Extension [s]	2.0	2.5	0.0	2.5	2.5	0.0	2.0	3.0	0.0	2.0	3.0	3.0
Minimum Recall	Yes	No		No	No		Yes	Yes		Yes	Yes	Yes
Maximum Recall	No	No		No	No		No	No		No	No	No
Pedestrian Recall	No	No		No	No		No	No		No	No	No

**Exclusive Pedestrian Phase**

Pedestrian Signal Group	0
Pedestrian Walk [s]	0
Pedestrian Clearance [s]	0



**Lane Group Calculations**

Lane Group	L	C	C	L	C	R	L	C	R	L	C	R
C, Cycle Length [s]	44	44	44	44	44	44	44	44	44	44	44	44
L, Total Lost Time per Cycle [s]	4.00	4.00	4.00	4.00	4.00	4.00	4.00	4.00	4.00	4.00	4.00	4.00
l1_p, Permitted Start-Up Lost Time [s]	0.00	0.00	0.00	0.00	0.00	0.00	0.00	0.00	0.00	0.00	0.00	0.00
l2, Clearance Lost Time [s]	0.00	2.00	2.00	2.00	2.00	2.00	0.00	2.00	2.00	0.00	2.00	0.00
g_i, Effective Green Time [s]	20	3	3	13	16	16	16	12	12	16	8	25
g / C, Green / Cycle	0.45	0.07	0.07	0.29	0.35	0.35	0.37	0.27	0.27	0.37	0.19	0.57
(v / s)_i Volume / Saturation Flow Rate	0.00	0.00	0.01	0.13	0.01	0.24	0.20	0.12	0.00	0.01	0.05	0.25
s, saturation flow rate [veh/h]	1077	3046	1360	5259	1234	1605	3093	3603	1615	1085	3566	2845
c, Capacity [veh/h]	886	216	97	1513	437	568	1469	975	437	550	673	1613
d1, Uniform Delay [s]	7.87	19.14	19.20	12.95	9.29	12.19	10.92	13.38	11.82	9.88	15.33	5.51
k, delay calibration	0.08	0.08	0.08	0.08	0.08	0.08	0.04	0.11	0.11	0.11	0.11	0.11
l, Upstream Filtering Factor	1.00	1.00	1.00	1.00	1.00	1.00	1.00	1.00	1.00	1.00	1.00	1.00
d2, Incremental Delay [s]	0.00	0.07	0.31	0.17	0.02	1.11	0.07	0.32	0.02	0.01	0.22	0.19
d3, Initial Queue Delay [s]	0.00	0.00	0.00	0.00	0.00	0.00	0.00	0.00	0.00	0.00	0.00	0.00
Rp, platoon ratio	1.00	1.00	1.00	1.00	1.00	1.00	1.00	1.00	1.00	1.00	1.00	1.00
PF, progression factor	1.00	1.00	1.00	1.00	1.00	1.00	1.00	1.00	1.00	1.00	1.00	1.00

**Lane Group Results**

X, volume / capacity	0.00	0.05	0.09	0.47	0.02	0.69	0.41	0.45	0.02	0.01	0.27	0.44
d, Delay for Lane Group [s/veh]	7.87	19.21	19.51	13.12	9.31	13.30	10.99	13.70	11.83	9.89	15.54	5.70
Lane Group LOS	A	B	B	B	A	B	B	B	B	A	B	A
Critical Lane Group	Yes	No	No	No	No	Yes	Yes	No	No	No	No	Yes
50th-Percentile Queue Length [veh/ln]	0.02	0.05	0.09	1.62	0.05	2.78	1.20	1.54	0.05	0.04	0.70	1.18
50th-Percentile Queue Length [ft/ln]	0.45	1.23	2.13	40.39	1.32	69.49	29.92	38.58	1.27	1.08	17.51	29.57
95th-Percentile Queue Length [veh/ln]	0.03	0.09	0.15	2.91	0.09	5.00	2.15	2.78	0.09	0.08	1.26	2.13
95th-Percentile Queue Length [ft/ln]	0.82	2.21	3.84	72.70	2.37	125.09	53.86	69.45	2.28	1.95	31.51	53.22



**Movement, Approach, & Intersection Results**

d_M, Delay for Movement [s/veh]	7.87	19.21	19.51	13.12	9.31	13.30	10.99	13.70	11.83	9.89	15.54	5.70
Movement LOS	A	B	B	B	A	B	B	B	B	A	B	A
d_A, Approach Delay [s/veh]	17.43			13.15			12.12			7.74		
Approach LOS	B			B			B			A		
d_I, Intersection Delay [s/veh]	11.26											
Intersection LOS	B											
Intersection V/C	0.691											

**Emissions**

Vehicle Miles Traveled [mph]	0.25	0.70	0.57	121.71	1.72	67.31	77.49	55.66	1.02	1.39	31.79	122.83
Stops [stops/h]	1.48	8.01	6.96	395.74	4.30	226.96	293.17	252.01	4.13	3.54	114.35	193.14
Fuel consumption [US gal/h]	0.03	0.12	0.10	9.09	0.11	5.08	6.17	4.90	0.08	0.09	2.52	6.94
CO [g/h]	1.75	8.11	6.83	635.05	7.94	355.33	431.15	342.47	5.88	6.49	176.11	485.38
NOx [g/h]	0.34	1.58	1.33	123.56	1.54	69.13	83.89	66.63	1.14	1.26	34.26	94.44
VOC [g/h]	0.41	1.88	1.58	147.18	1.84	82.35	99.92	79.37	1.36	1.50	40.82	112.49

**Other Modes**

g_Walk,mi, Effective Walk Time [s]	9.0			0.0			9.0			9.0		
M_corner, Corner Circulation Area [ft <sup>2</sup> /ped]	0.00			0.00			0.00			0.00		
M_CW, Crosswalk Circulation Area [ft <sup>2</sup> /ped]	0.00			0.00			0.00			0.00		
d_p, Pedestrian Delay [s]	13.96			0.00			13.96			13.96		
I_p,int, Pedestrian LOS Score for Intersectio	2.276			0.000			2.991			2.938		
Crosswalk LOS	B			F			C			C		
s_b, Saturation Flow Rate of the bicycle lane	2000			2000			2000			2000		
c_b, Capacity of the bicycle lane [bicycles/h]	1134			907			1134			907		
d_b, Bicycle Delay [s]	4.13			6.58			4.13			6.58		
I_b,int, Bicycle LOS Score for Intersection	1.573			3.388			2.427			2.300		
Bicycle LOS	A			C			B			B		

**Sequence**

Ring 1	1	2	3	4	-	-	-	-	-	-	-	-	-	-	-
Ring 2	5	6	7	8	-	-	-	-	-	-	-	-	-	-	-
Ring 3	-	-	-	-	-	-	-	-	-	-	-	-	-	-	-
Ring 4	-	-	-	-	-	-	-	-	-	-	-	-	-	-	-



**Intersection Level Of Service Report**  
**Intersection 14: Central Parkway & Sunset View Drive**

Control Type:	Signalized	Delay (sec / veh):	11.1
Analysis Method:	HCM 7th Edition	Level Of Service:	B
Analysis Period:	15 minutes	Volume to Capacity (v/c):	0.259

**Intersection Setup**

Name	Driveway			Sunset View Drive			Central Parkway			Central Parkway		
Approach	Northbound			Southbound			Eastbound			Westbound		
Lane Configuration	↵↵			↵↵			↵↵↵			↵↵		
Turning Movement	Left	Thru	Right	Left	Thru	Right	Left	Thru	Right	Left	Thru	Right
Lane Width [ft]	12.00	12.00	12.00	12.00	12.00	12.00	12.00	12.00	12.00	12.00	12.00	12.00
No. of Lanes in Entry Pocket	1	0	0	0	0	1	1	0	1	1	0	0
Entry Pocket Length [ft]	250.00	100.00	100.00	100.00	100.00	85.00	225.00	100.00	800.00	150.00	100.00	100.00
No. of Lanes in Exit Pocket	0	0	0	0	0	0	0	0	0	0	0	0
Exit Pocket Length [ft]	0.00	0.00	0.00	0.00	0.00	0.00	0.00	0.00	0.00	0.00	0.00	0.00
Speed [mph]	30.00			30.00			30.00			30.00		
Grade [%]	0.00			0.00			0.00			0.00		
Curb Present	No			No			No			No		
Crosswalk	Yes			Yes			Yes			Yes		



**Volumes**

Name	Driveway			Sunset View Drive			Central Parkway			Central Parkway		
Base Volume Input [veh/h]	8	0	2	3	0	74	81	141	9	0	94	1
Base Volume Adjustment Factor	1.0000	1.0000	1.0000	1.0000	1.0000	1.0000	1.0000	1.0000	1.0000	1.0000	1.0000	1.0000
Heavy Vehicles Percentage [%]	0.00	0.00	0.00	0.00	0.00	0.00	0.00	0.00	0.00	0.00	0.00	0.00
Proportion of CAVs [%]	0.00											
Growth Factor	1.0000	1.0000	1.0000	1.0000	1.0000	1.0000	1.0000	1.0000	1.0000	1.0000	1.0000	1.0000
In-Process Volume [veh/h]	0	0	0	0	0	0	0	0	0	0	0	0
Site-Generated Trips [veh/h]	0	0	0	0	0	0	0	0	0	0	0	0
Diverted Trips [veh/h]	0	0	0	0	0	0	0	0	0	0	0	0
Pass-by Trips [veh/h]	0	0	0	0	0	0	0	0	0	0	0	0
Existing Site Adjustment Volume [veh/h]	0	0	0	0	0	0	0	0	0	0	0	0
Other Volume [veh/h]	0	0	0	0	0	0	0	0	0	0	0	0
Right Turn on Red Volume [veh/h]	0	0	0	0	0	0	0	0	0	0	0	0
Total Hourly Volume [veh/h]	8	0	2	3	0	74	81	141	9	0	94	1
Peak Hour Factor	0.9200	0.9200	0.9200	0.9200	0.9200	0.9200	0.9200	0.9200	0.9200	0.9200	0.9200	0.9200
Other Adjustment Factor	1.0000	1.0000	1.0000	1.0000	1.0000	1.0000	1.0000	1.0000	1.0000	1.0000	1.0000	1.0000
Total 15-Minute Volume [veh/h]	2	0	1	1	0	20	22	38	2	0	26	0
Total Analysis Volume [veh/h]	9	0	2	3	0	80	88	153	10	0	102	1
Presence of On-Street Parking	No		No	No		No	No		No	No		No
On-Street Parking Maneuver Rate [/h]	0	0	0	0	0	0	0	0	0	0	0	0
Local Bus Stopping Rate [/h]	0	0	0	0	0	0	0	0	0	0	0	0
v_do, Outbound Pedestrian Volume crossing	2			1			1			0		
v_di, Inbound Pedestrian Volume crossing m	1			0			2			1		
v_co, Outbound Pedestrian Volume crossing	0			0			0			0		
v_ci, Inbound Pedestrian Volume crossing mi	0			0			0			0		
v_ab, Corner Pedestrian Volume [ped/h]	0			0			0			0		
Bicycle Volume [bicycles/h]	0			0			1			0		



**Intersection Settings**

Located in CBD	No
Signal Coordination Group	-
Cycle Length [s]	90
Active Pattern	Free Running (No Pattern)
Coordination Type	<i>Free Running</i>
Actuation Type	<i>Fully actuated</i>
Offset [s]	0.0
Offset Reference	Lead Green - Beginning of First Green
Permissive Mode	SingleBand
Lost time [s]	12.00

**Phasing & Timing (Basic)**

Control Type	Protecte	Permiss	Permiss	Protecte	Permiss	Permiss	Protecte	Permiss	Permiss	Protecte	Permiss	Permiss
Signal Group	3	8	0	7	4	0	5	2	0	1	6	0
Auxiliary Signal Groups												
Maximum Green [s]	30	30	0	20	20	0	20	25	0	20	25	0
Amber [s]	3.0	3.0	0.0	3.0	3.0	0.0	3.0	3.6	0.0	3.0	3.6	0.0
All red [s]	1.0	1.0	0.0	1.0	1.0	0.0	1.0	1.0	0.0	1.0	1.0	0.0
Walk [s]	0	4	0	0	4	0	0	4	0	0	4	0
Pedestrian Clearance [s]	0	24	0	0	21	0	0	16	0	0	17	0
Delayed Vehicle Green [s]	0.0	0.0	0.0	0.0	0.0	0.0	0.0	0.0	0.0	0.0	0.0	0.0
Rest In Walk		No			No			No			No	
I1, Start-Up Lost Time [s]	2.0	2.0	0.0	2.0	2.0	0.0	2.0	2.0	0.0	2.0	2.0	0.0
I2, Clearance Lost Time [s]	2.0	2.0	0.0	2.0	2.0	0.0	2.0	2.0	0.0	2.0	2.0	0.0
Detector Location [ft]	0.0	0.0	0.0	0.0	0.0	0.0	0.0	0.0	0.0	0.0	0.0	0.0
Detector Length [ft]	20.0	20.0	0.0	20.0	20.0	0.0	20.0	20.0	0.0	20.0	20.0	0.0
I, Upstream Filtering Factor	1.00	1.00	1.00	1.00	1.00	1.00	1.00	1.00	1.00	1.00	1.00	1.00

**Phasing & Timing: Free Running (No Pattern)**

Split [s]	9	14	0	9	14	0	9	14	0	9	14	0
Lead / Lag	Lead	-	-	Lead	-	-	Lead	-	-	Lead	-	-
Minimum Green [s]	5	10	0	5	10	0	5	10	0	5	10	0
Vehicle Extension [s]	2.0	4.0	0.0	2.0	4.0	0.0	2.0	4.0	0.0	2.0	4.0	0.0
Minimum Recall	No	No		No	No		No	Yes		No	Yes	
Maximum Recall	No	No		No	No		No	No		No	No	
Pedestrian Recall	No	No		No	No		No	No		No	No	

**Exclusive Pedestrian Phase**

Pedestrian Signal Group	0
Pedestrian Walk [s]	0
Pedestrian Clearance [s]	0



**Lane Group Calculations**

Lane Group	L	C	L	C	L	C	R	L	C
C, Cycle Length [s]	31	31	31	31	31	31	31	31	31
L, Total Lost Time per Cycle [s]	4.00	4.00	4.00	4.00	4.00	4.00	4.00	4.00	4.00
l1_p, Permitted Start-Up Lost Time [s]	0.00	0.00	0.00	0.00	0.00	0.00	0.00	0.00	0.00
l2, Clearance Lost Time [s]	2.00	2.00	2.00	2.00	2.00	2.00	2.00	2.00	2.00
g_i, Effective Green Time [s]	0	5	0	5	3	9	9	0	7
g / C, Green / Cycle	0.01	0.17	0.00	0.16	0.09	0.30	0.30	0.00	0.21
(v / s)_i Volume / Saturation Flow Rate	0.00	0.00	0.00	0.05	0.05	0.08	0.01	0.00	0.05
s, saturation flow rate [veh/h]	1810	1615	1810	1615	1810	1900	1573	1810	1897
c, Capacity [veh/h]	23	280	8	266	159	577	477	1	409
d1, Uniform Delay [s]	15.11	10.56	15.31	11.32	13.49	8.14	7.53	0.00	10.03
k, delay calibration	0.04	0.15	0.04	0.15	0.04	0.15	0.15	0.04	0.15
l, Upstream Filtering Factor	1.00	1.00	1.00	1.00	1.00	1.00	1.00	1.00	1.00
d2, Incremental Delay [s]	3.82	0.01	9.60	0.89	1.11	0.35	0.02	0.00	0.45
d3, Initial Queue Delay [s]	0.00	0.00	0.00	0.00	0.00	0.00	0.00	0.00	0.00
Rp, platoon ratio	1.00	1.00	1.00	1.00	1.00	1.00	1.00	1.00	1.00
PF, progression factor	1.00	1.00	1.00	1.00	1.00	1.00	1.00	1.00	1.00

**Lane Group Results**

X, volume / capacity	0.39	0.01	0.36	0.30	0.55	0.27	0.02	0.00	0.25
d, Delay for Lane Group [s/veh]	18.93	10.58	24.92	12.22	14.60	8.49	7.56	0.00	10.49
Lane Group LOS	B	B	C	B	B	A	A	A	B
Critical Lane Group	Yes	No	No	Yes	Yes	No	No	No	Yes
50th-Percentile Queue Length [veh/ln]	0.07	0.01	0.04	0.42	0.50	0.57	0.03	0.00	0.47
50th-Percentile Queue Length [ft/ln]	1.87	0.24	0.97	10.58	12.55	14.13	0.85	0.00	11.66
95th-Percentile Queue Length [veh/ln]	0.13	0.02	0.07	0.76	0.90	1.02	0.06	0.00	0.84
95th-Percentile Queue Length [ft/ln]	3.37	0.43	1.75	19.05	22.59	25.44	1.54	0.00	20.99





**Movement, Approach, & Intersection Results**

d_M, Delay for Movement [s/veh]	18.93	10.58	10.58	24.92	12.22	12.22	14.60	8.49	7.56	0.00	10.49	10.49
Movement LOS	B	B	B	C	B	B	B	A	A	A	B	B
d_A, Approach Delay [s/veh]	17.41			12.68			10.59			10.49		
Approach LOS	B			B			B			B		
d_I, Intersection Delay [s/veh]	11.12											
Intersection LOS	B											
Intersection V/C	0.259											

**Emissions**

Vehicle Miles Traveled [mph]	0.25	0.05	0.11	2.97	20.01	34.78	2.27	0.00	21.77
Stops [stops/h]	8.78	1.11	4.56	49.65	58.89	66.33	4.00	0.00	54.72
Fuel consumption [US gal/h]	0.09	0.01	0.05	0.60	1.41	2.06	0.13	0.00	1.42
CO [g/h]	6.52	0.89	3.15	41.64	98.59	144.18	9.16	0.00	99.16
NOx [g/h]	1.27	0.17	0.61	8.10	19.18	28.05	1.78	0.00	19.29
VOC [g/h]	1.51	0.21	0.73	9.65	22.85	33.41	2.12	0.00	22.98

**Other Modes**

g_Walk,mi, Effective Walk Time [s]	8.0	8.0	8.0	8.0
M_corner, Corner Circulation Area [ft <sup>2</sup> /ped]	0.00	0.00	0.00	0.00
M_CW, Crosswalk Circulation Area [ft <sup>2</sup> /ped]	0.00	0.00	0.00	0.00
d_p, Pedestrian Delay [s]	8.39	8.39	8.39	8.39
I_p,int, Pedestrian LOS Score for Intersectio	1.890	1.939	2.181	1.968
Crosswalk LOS	A	A	B	A
s_b, Saturation Flow Rate of the bicycle lane	2000	2000	2000	2000
c_b, Capacity of the bicycle lane [bicycles/h]	1955	1304	1629	1629
d_b, Bicycle Delay [s]	0.01	1.86	0.53	0.53
I_b,int, Bicycle LOS Score for Intersection	1.578	1.697	1.974	1.730
Bicycle LOS	A	A	A	A

**Sequence**

Ring 1	1	2	3	4	-	-	-	-	-	-	-	-	-	-	-
Ring 2	5	6	7	8	-	-	-	-	-	-	-	-	-	-	-
Ring 3	-	-	-	-	-	-	-	-	-	-	-	-	-	-	-
Ring 4	-	-	-	-	-	-	-	-	-	-	-	-	-	-	-

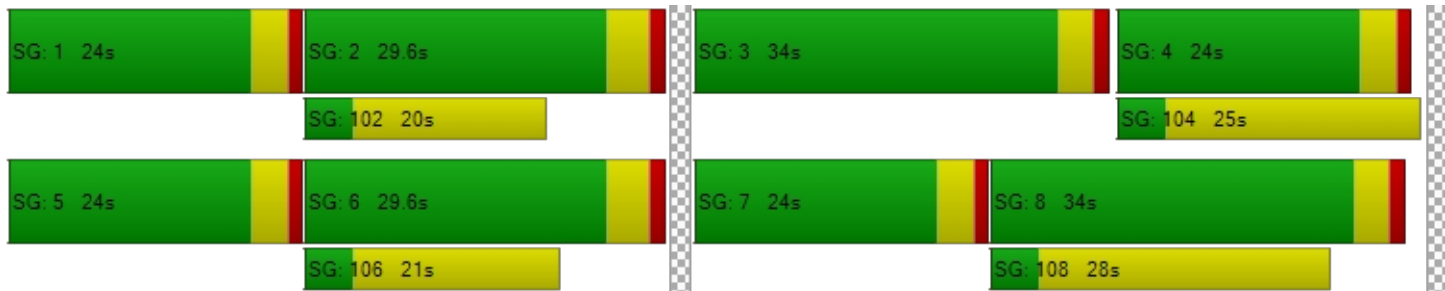

**Intersection Level Of Service Report**

**Intersection 15: Central Parkway & Panorama Drive/Pino Grande Road**

Control Type:	All-way stop	Delay (sec / veh):	8.0
Analysis Method:	HCM 7th Edition	Level Of Service:	A
Analysis Period:	15 minutes	Volume to Capacity (v/c):	0.146

**Intersection Setup**

Name	Pino Grande Road			Panorama Drive			Central Parkway			Central Parkway		
Approach	Northbound			Southbound			Eastbound			Westbound		
Lane Configuration	+			+r			+r			+r		
Turning Movement	Left	Thru	Right	Left	Thru	Right	Left	Thru	Right	Left	Thru	Right
Lane Width [ft]	12.00	12.00	12.00	12.00	12.00	12.00	12.00	12.00	12.00	12.00	12.00	12.00
No. of Lanes in Entry Pocket	0	0	0	0	0	1	1	0	0	1	0	0
Entry Pocket Length [ft]	100.00	100.00	100.00	100.00	100.00	100.00	275.00	100.00	100.00	100.00	100.00	100.00
No. of Lanes in Exit Pocket	0	0	0	0	0	0	0	0	0	0	0	0
Exit Pocket Length [ft]	0.00	0.00	0.00	0.00	0.00	0.00	0.00	0.00	0.00	0.00	0.00	0.00
Speed [mph]	30.00			30.00			30.00			30.00		
Grade [%]	0.00			0.00			0.00			0.00		
Crosswalk	Yes			Yes			Yes			Yes		

**Volumes**

Name	Pino Grande Road			Panorama Drive			Central Parkway			Central Parkway		
Base Volume Input [veh/h]	10	0	0	0	0	64	95	39	10	0	26	0
Base Volume Adjustment Factor	1.0000	1.0000	1.0000	1.0000	1.0000	1.0000	1.0000	1.0000	1.0000	1.0000	1.0000	1.0000
Heavy Vehicles Percentage [%]	0.00	0.00	0.00	0.00	0.00	0.00	0.00	0.00	0.00	0.00	0.00	0.00
Growth Factor	1.0000	1.0000	1.0000	1.0000	1.0000	1.0000	1.0000	1.0000	1.0000	1.0000	1.0000	1.0000
In-Process Volume [veh/h]	0	0	0	0	0	0	0	0	0	0	0	0
Site-Generated Trips [veh/h]	0	0	0	0	0	0	0	0	0	0	0	0
Diverted Trips [veh/h]	0	0	0	0	0	0	0	0	0	0	0	0
Pass-by Trips [veh/h]	0	0	0	0	0	0	0	0	0	0	0	0
Existing Site Adjustment Volume [veh/h]	0	0	0	0	0	0	0	0	0	0	0	0
Other Volume [veh/h]	0	0	0	0	0	0	0	0	0	0	0	0
Total Hourly Volume [veh/h]	10	0	0	0	0	64	95	39	10	0	26	0
Peak Hour Factor	0.9400	0.9400	0.9400	0.9400	0.9400	0.9400	0.9400	0.9400	0.9400	0.9400	0.9400	0.9400
Other Adjustment Factor	1.0000	1.0000	1.0000	1.0000	1.0000	1.0000	1.0000	1.0000	1.0000	1.0000	1.0000	1.0000
Total 15-Minute Volume [veh/h]	3	0	0	0	0	17	25	10	3	0	7	0
Total Analysis Volume [veh/h]	11	0	0	0	0	68	101	41	11	0	28	0
Pedestrian Volume [ped/h]	2			3			2			4		



**Intersection Settings**

**Lanes**

Capacity per Entry Lane [veh/h]	690	725	844	691	790	748	748
Degree of Utilization, x	0.02	0.00	0.08	0.15	0.07	0.00	0.04

**Movement, Approach, & Intersection Results**

95th-Percentile Queue Length [veh]	0.05	0.00	0.26	0.51	0.21	0.00	0.12
95th-Percentile Queue Length [ft]	1.22	0.00	6.55	12.75	5.28	0.00	2.91
Approach Delay [s/veh]	8.31	7.34		8.39		7.70	
Approach LOS	A	A		A		A	
Intersection Delay [s/veh]	8.03						
Intersection LOS	A						



**Intersection Level Of Service Report**  
**Intersection 16: Airway Boulevard & N. Canyons Parkway**

Control Type:	Signalized	Delay (sec / veh):	16.4
Analysis Method:	HCM 7th Edition	Level Of Service:	B
Analysis Period:	15 minutes	Volume to Capacity (v/c):	0.455

**Intersection Setup**

Name	Airway Boulevard			Driveway			N. Canyons Parkway			N Canyons Parkway		
Approach	Northbound			Southbound			Eastbound			Westbound		
Lane Configuration	⇌⇌⇌			+			⇌⇌			⇌⇌⇌		
Turning Movement	Left	Thru	Right	Left	Thru	Right	Left	Thru	Right	Left	Thru	Right
Lane Width [ft]	12.00	12.00	12.00	12.00	12.00	12.00	12.00	12.00	12.00	12.00	12.00	12.00
No. of Lanes in Entry Pocket	0	0	0	0	0	0	0	0	0	1	0	1
Entry Pocket Length [ft]	100.00	100.00	100.00	100.00	100.00	100.00	100.00	100.00	100.00	110.00	100.00	195.00
No. of Lanes in Exit Pocket	0	0	0	0	0	0	0	0	0	0	0	0
Exit Pocket Length [ft]	0.00	0.00	0.00	0.00	0.00	0.00	0.00	0.00	0.00	0.00	0.00	0.00
Speed [mph]	40.00			30.00			40.00			40.00		
Grade [%]	0.00			0.00			0.00			0.00		
Curb Present	Yes			Yes			Yes			Yes		
Crosswalk	Yes			Yes			Yes			No		



**Volumes**

Name	Airway Boulevard			Driveway			N. Canyons Parkway			N Canyons Parkway		
Base Volume Input [veh/h]	112	39	491	2	8	2	0	22	121	727	15	9
Base Volume Adjustment Factor	1.0000	1.0000	1.0000	1.0000	1.0000	1.0000	1.0000	1.0000	1.0000	1.0000	1.0000	1.0000
Heavy Vehicles Percentage [%]	4.50	2.60	1.20	0.00	0.00	0.00	2.00	0.00	1.70	0.70	0.00	0.00
Proportion of CAVs [%]	0.00											
Growth Factor	1.0000	1.0000	1.0000	1.0000	1.0000	1.0000	1.0000	1.0000	1.0000	1.0000	1.0000	1.0000
In-Process Volume [veh/h]	0	0	0	0	0	0	0	0	0	0	0	0
Site-Generated Trips [veh/h]	0	0	0	0	0	0	0	0	0	0	0	0
Diverted Trips [veh/h]	0	0	0	0	0	0	0	0	0	0	0	0
Pass-by Trips [veh/h]	0	0	0	0	0	0	0	0	0	0	0	0
Existing Site Adjustment Volume [veh/h]	0	0	0	0	0	0	0	0	0	0	0	0
Other Volume [veh/h]	0	0	0	0	0	0	0	0	0	0	0	0
Right Turn on Red Volume [veh/h]	0	0	0	0	0	0	0	0	0	0	0	0
Total Hourly Volume [veh/h]	112	39	491	2	8	2	0	22	121	727	15	9
Peak Hour Factor	0.9300	0.9300	0.9300	0.9300	0.9300	0.9300	1.0000	0.9300	0.9300	0.9300	0.9300	0.9300
Other Adjustment Factor	1.0000	1.0000	1.0000	1.0000	1.0000	1.0000	1.0000	1.0000	1.0000	1.0000	1.0000	1.0000
Total 15-Minute Volume [veh/h]	30	10	132	1	2	1	0	6	33	195	4	2
Total Analysis Volume [veh/h]	120	42	528	2	9	2	0	24	130	782	16	10
Presence of On-Street Parking	No		No	No		No	No		No	No		No
On-Street Parking Maneuver Rate [/h]	0	0	0	0	0	0	0	0	0	0	0	0
Local Bus Stopping Rate [/h]	0	0	0	0	0	0	0	0	0	0	0	0
v_do, Outbound Pedestrian Volume crossing	2			0			1			0		
v_di, Inbound Pedestrian Volume crossing m	1			0			2			0		
v_co, Outbound Pedestrian Volume crossing	0			0			0			0		
v_ci, Inbound Pedestrian Volume crossing mi	0			0			0			0		
v_ab, Corner Pedestrian Volume [ped/h]	0			0			0			0		
Bicycle Volume [bicycles/h]	0			0			0			0		



**Intersection Settings**

Located in CBD	No
Signal Coordination Group	-
Cycle Length [s]	105
Active Pattern	Pattern 1
Coordination Type	Time of Day Pattern Coordinated
Actuation Type	Fully actuated
Offset [s]	100.0
Offset Reference	Lead Green - Beginning of First Green
Permissive Mode	SingleBand
Lost time [s]	12.00

**Phasing & Timing (Basic)**

Control Type	Split	Split	Overlap	Split	Split	Split	Permiss	Permiss	Permiss	Protecte	Permiss	Permiss
Signal Group	0	8	8	0	4	0	0	2	0	1	6	0
Auxiliary Signal Groups			1,8									
Maximum Green [s]	0	20	20	0	12	0	0	15	0	50	50	0
Amber [s]	0.0	3.2	3.2	0.0	3.0	0.0	0.0	5.0	0.0	5.0	5.0	0.0
All red [s]	0.0	1.0	1.0	0.0	1.0	0.0	0.0	1.0	0.0	1.0	1.0	0.0
Walk [s]	0	0	0	0	5	0	0	5	0	0	5	0
Pedestrian Clearance [s]	0	0	0	0	28	0	0	29	0	0	12	0
Delayed Vehicle Green [s]	0.0	0.0	0.0	0.0	0.0	0.0	0.0	0.0	0.0	0.0	0.0	0.0
Rest In Walk		No			No			No			No	
I1, Start-Up Lost Time [s]	0.0	2.0	2.0	0.0	2.0	0.0	0.0	2.0	0.0	2.0	2.0	0.0
I2, Clearance Lost Time [s]	0.0	2.0	2.0	0.0	2.0	0.0	0.0	2.0	0.0	2.0	2.0	0.0
Detector Location [ft]	0.0	0.0	0.0	0.0	0.0	0.0	0.0	0.0	0.0	0.0	0.0	0.0
Detector Length [ft]	0.0	20.0	20.0	0.0	20.0	0.0	0.0	20.0	0.0	20.0	20.0	0.0
I, Upstream Filtering Factor	1.00	1.00	1.00	1.00	1.00	1.00	1.00	1.00	1.00	1.00	1.00	1.00

**Phasing & Timing: Pattern 1**

Split [s]	0	22	22	0	20	0	0	33	0	30	63	0
Lead / Lag	-	-	-	-	-	-	-	-	-	Lead	-	-
Minimum Green [s]	0	4	4	0	3	0	0	10	0	3	7	0
Vehicle Extension [s]	0.0	2.0	2.0	0.0	2.0	0.0	0.0	2.0	0.0	2.0	2.0	0.0
Minimum Recall		No	No		No			No		No	Yes	
Maximum Recall		No	No		No			No		Yes	Yes	
Pedestrian Recall		No	No		No			No		No	No	

**Exclusive Pedestrian Phase**

Pedestrian Signal Group	0
Pedestrian Walk [s]	0
Pedestrian Clearance [s]	0



**Lane Group Calculations**

Lane Group	C	R	C	C	R	L	C	R
C, Cycle Length [s]	105	105	105	105	105	105	105	105
L, Total Lost Time per Cycle [s]	4.00	4.00	4.00	4.00	4.00	4.00	4.00	4.00
l1_p, Permitted Start-Up Lost Time [s]	0.00	0.00	0.00	0.00	0.00	0.00	0.00	0.00
l2, Clearance Lost Time [s]	2.00	0.00	2.00	2.00	2.00	2.00	2.00	2.00
g_i, Effective Green Time [s]	13	79	1	13	13	62	80	80
g / C, Green / Cycle	0.12	0.75	0.01	0.13	0.13	0.59	0.76	0.76
(v / s)_i Volume / Saturation Flow Rate	0.09	0.19	0.01	0.01	0.08	0.22	0.01	0.01
s, saturation flow rate [veh/h]	1795	2831	1836	3618	1582	3495	1900	1615
c, Capacity [veh/h]	214	2069	17	458	200	2070	1438	1223
d1, Uniform Delay [s]	44.78	4.68	51.90	40.34	43.63	11.24	3.13	3.12
k, delay calibration	0.04	0.50	0.04	0.04	0.04	0.50	0.50	0.50
l, Upstream Filtering Factor	1.00	1.00	1.00	1.00	1.00	1.00	1.00	1.00
d2, Incremental Delay [s]	2.06	0.30	20.97	0.02	1.32	0.53	0.01	0.01
d3, Initial Queue Delay [s]	0.00	0.00	0.00	0.00	0.00	0.00	0.00	0.00
Rp, platoon ratio	1.00	1.00	1.00	1.00	1.00	1.00	1.00	1.00
PF, progression factor	1.00	1.00	1.00	1.00	1.00	1.00	1.00	1.00

**Lane Group Results**

X, volume / capacity	0.76	0.26	0.75	0.05	0.65	0.38	0.01	0.01
d, Delay for Lane Group [s/veh]	46.84	4.98	72.88	40.35	44.95	11.77	3.14	3.13
Lane Group LOS	D	A	E	D	D	B	A	A
Critical Lane Group	Yes	No	Yes	No	Yes	Yes	No	No
50th-Percentile Queue Length [veh/ln]	4.10	1.55	0.44	0.27	3.21	4.45	0.07	0.04
50th-Percentile Queue Length [ft/ln]	102.61	38.73	11.04	6.72	80.21	111.32	1.65	1.04
95th-Percentile Queue Length [veh/ln]	7.39	2.79	0.80	0.48	5.78	7.91	0.12	0.08
95th-Percentile Queue Length [ft/ln]	184.70	69.71	19.88	12.09	144.38	197.84	2.97	1.88

**Movement, Approach, & Intersection Results**

d_M, Delay for Movement [s/veh]	46.84	46.84	4.98	72.88	72.88	72.88	0.00	40.35	44.95	11.77	3.14	3.13
Movement LOS	D	D	A	E	E	E		D	D	B	A	A
d_A, Approach Delay [s/veh]	14.81			72.88				44.24		11.49		
Approach LOS	B			E				D		B		
d_I, Intersection Delay [s/veh]	16.37											
Intersection LOS	B											
Intersection V/C	0.455											

**Emissions**

Vehicle Miles Traveled [mph]	19.24	62.69	0.45	1.56	8.47	63.96	1.31	0.82
Stops [stops/h]	140.69	106.20	15.14	18.42	109.98	305.27	2.26	1.43
Fuel consumption [US gal/h]	3.62	3.82	0.29	0.43	2.57	7.16	0.08	0.05
CO [g/h]	252.70	267.31	20.61	30.34	179.85	500.71	5.54	3.48
NOx [g/h]	49.17	52.01	4.01	5.90	34.99	97.42	1.08	0.68
VOC [g/h]	58.57	61.95	4.78	7.03	41.68	116.04	1.28	0.81

**Other Modes**

g_Walk,mi, Effective Walk Time [s]	9.0	9.0	9.0	0.0
M_corner, Corner Circulation Area [ft <sup>2</sup> /ped]	0.00	0.00	0.00	0.00
M_CW, Crosswalk Circulation Area [ft <sup>2</sup> /ped]	2011.68	0.00	0.00	0.00
d_p, Pedestrian Delay [s]	43.90	43.90	43.90	0.00
I_p,int, Pedestrian LOS Score for Intersectio	2.811	1.756	2.385	0.000
Crosswalk LOS	C	A	B	F
s_b, Saturation Flow Rate of the bicycle lane	2000	2000	2000	2000
c_b, Capacity of the bicycle lane [bicycles/h]	339	305	514	1085
d_b, Bicycle Delay [s]	36.22	37.73	28.98	10.98
I_b,int, Bicycle LOS Score for Intersection	2.698	1.581	1.687	2.893
Bicycle LOS	B	A	A	C

**Sequence**

Ring 1	1	2	4	8	-	-	-	-	-	-	-	-	-	-	-
Ring 2	-	6	-	-	-	-	-	-	-	-	-	-	-	-	-
Ring 3	-	-	-	-	-	-	-	-	-	-	-	-	-	-	-
Ring 4	-	-	-	-	-	-	-	-	-	-	-	-	-	-	-

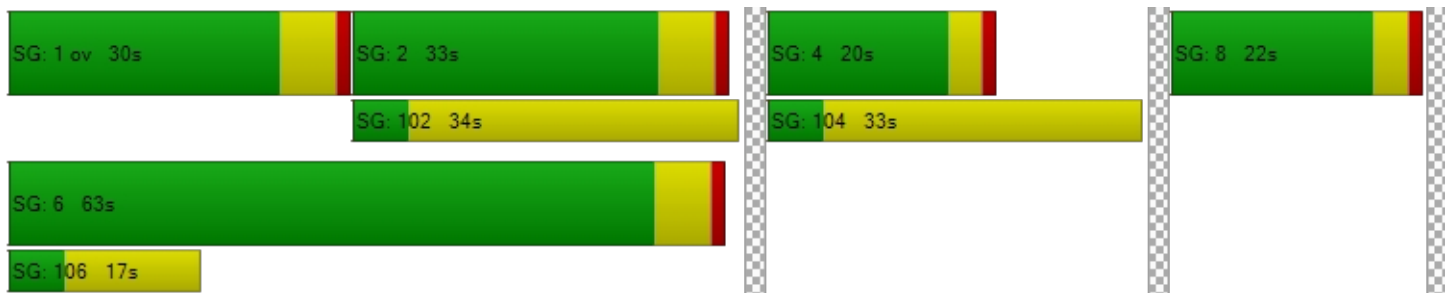



**Intersection Level Of Service Report**  
**Intersection 17: Airway Boulevard & I-580 WB Ramps**

Control Type:	Signalized	Delay (sec / veh):	10.1
Analysis Method:	HCM 7th Edition	Level Of Service:	B
Analysis Period:	15 minutes	Volume to Capacity (v/c):	0.214

**Intersection Setup**

Name	Airway Boulevard			Airway Boulevard			I-580 WB On-Ramp			I-580 WB Off-Ramp		
Approach	Northbound			Southbound			Eastbound			Westbound		
Lane Configuration	r			r						r rr		
Turning Movement	Left	Thru	Right	Left	Thru	Right	Left	Thru	Right	Left	Thru	Right
Lane Width [ft]	12.00	12.00	12.00	12.00	12.00	12.00	12.00	12.00	12.00	12.00	12.00	12.00
No. of Lanes in Entry Pocket	0	0	0	0	0	1	0	0	0	1	0	1
Entry Pocket Length [ft]	100.00	100.00	100.00	100.00	100.00	250.00	100.00	100.00	100.00	150.00	100.00	490.00
No. of Lanes in Exit Pocket	0	0	0	0	0	0	0	0	0	0	0	0
Exit Pocket Length [ft]	0.00	0.00	0.00	0.00	0.00	0.00	0.00	0.00	0.00	0.00	0.00	0.00
Speed [mph]	40.00			40.00			30.00			45.00		
Grade [%]	0.00			0.00			0.00			0.00		
Curb Present	Yes			Yes						Yes		
Crosswalk	No			No			No			Yes		



**Volumes**

Name	Airway Boulevard			Airway Boulevard			I-580 WB On-Ramp			I-580 WB Off-Ramp		
	Base Volume Input [veh/h]	0	604	202	0	257	704	0	0	0	49	0
Base Volume Adjustment Factor	1.0000	1.0000	1.0000	1.0000	1.0000	1.0000	1.0000	1.0000	1.0000	1.0000	1.0000	1.0000
Heavy Vehicles Percentage [%]	2.00	1.20	0.00	2.00	0.40	0.70	2.00	2.00	2.00	0.00	0.00	1.10
Proportion of CAVs [%]	0.00											
Growth Factor	1.0000	1.0000	1.0000	1.0000	1.0000	1.0000	1.0000	1.0000	1.0000	1.0000	1.0000	1.0000
In-Process Volume [veh/h]	0	0	0	0	0	0	0	0	0	0	0	0
Site-Generated Trips [veh/h]	0	0	0	0	0	0	0	0	0	0	0	0
Diverted Trips [veh/h]	0	0	0	0	0	0	0	0	0	0	0	0
Pass-by Trips [veh/h]	0	0	0	0	0	0	0	0	0	0	0	0
Existing Site Adjustment Volume [veh/h]	0	0	0	0	0	0	0	0	0	0	0	0
Other Volume [veh/h]	0	0	0	0	0	0	0	0	0	0	0	0
Right Turn on Red Volume [veh/h]	0	0	0	0	0	0	0	0	0	0	0	0
Total Hourly Volume [veh/h]	0	604	202	0	257	704	0	0	0	49	0	175
Peak Hour Factor	1.0000	0.8900	0.8900	1.0000	0.8900	0.8900	1.0000	1.0000	1.0000	0.8900	0.8900	0.8900
Other Adjustment Factor	1.0000	1.0000	1.0000	1.0000	1.0000	1.0000	1.0000	1.0000	1.0000	1.0000	1.0000	1.0000
Total 15-Minute Volume [veh/h]	0	170	57	0	72	198	0	0	0	14	0	49
Total Analysis Volume [veh/h]	0	679	227	0	289	791	0	0	0	55	0	197
Presence of On-Street Parking	No		No	No		No				No		No
On-Street Parking Maneuver Rate [/h]	0	0	0	0	0	0	0	0	0	0	0	0
Local Bus Stopping Rate [/h]	0	0	0	0	0	0	0	0	0	0	0	0
v_do, Outbound Pedestrian Volume crossing	0			0			0			0		
v_di, Inbound Pedestrian Volume crossing m	0			0			0			0		
v_co, Outbound Pedestrian Volume crossing	0			0			0			0		
v_ci, Inbound Pedestrian Volume crossing mi	0			0			0			0		
v_ab, Corner Pedestrian Volume [ped/h]	0			0			0			0		
Bicycle Volume [bicycles/h]	1			0			0			0		



**Intersection Settings**

Located in CBD	No
Signal Coordination Group	-
Cycle Length [s]	105
Active Pattern	Pattern 1
Coordination Type	Time of Day Pattern Coordinated
Actuation Type	Fully actuated
Offset [s]	35.0
Offset Reference	Lead Green - Beginning of First Green
Permissive Mode	SingleBand
Lost time [s]	9.00

**Phasing & Timing (Basic)**

Control Type	Permiss	Permiss	Unsigna	Permiss	Permiss	Unsigna	Permiss	Permiss	Permiss	Permiss	Permiss	Overlap
Signal Group	0	2	0	0	6	0	0	0	0	0	8	1
Auxiliary Signal Groups												1,8
Maximum Green [s]	0	30	0	0	25	0	0	0	0	0	20	12
Amber [s]	0.0	4.3	0.0	0.0	4.3	0.0	0.0	0.0	0.0	0.0	3.0	3.0
All red [s]	0.0	1.0	0.0	0.0	1.0	0.0	0.0	0.0	0.0	0.0	1.0	0.0
Walk [s]	0	7	0	0	0	0	0	0	0	0	0	0
Pedestrian Clearance [s]	0	15	0	0	0	0	0	0	0	0	0	0
Delayed Vehicle Green [s]	0.0	0.0	0.0	0.0	0.0	0.0	0.0	0.0	0.0	0.0	0.0	0.0
Rest In Walk		No			No						No	
I1, Start-Up Lost Time [s]	0.0	2.0	0.0	0.0	2.0	0.0	0.0	0.0	0.0	0.0	2.0	2.0
I2, Clearance Lost Time [s]	0.0	2.0	0.0	0.0	2.0	0.0	0.0	0.0	0.0	0.0	2.0	2.0
Detector Location [ft]	0.0	0.0	0.0	0.0	0.0	0.0	0.0	0.0	0.0	0.0	0.0	0.0
Detector Length [ft]	0.0	20.0	0.0	0.0	20.0	0.0	0.0	0.0	0.0	0.0	20.0	20.0
I, Upstream Filtering Factor	1.00	1.00	1.00	1.00	1.00	1.00	1.00	1.00	1.00	1.00	1.00	1.00

**Phasing & Timing: Pattern 1**

Split [s]	0	68	0	0	83	0	0	0	0	0	22	15
Lead / Lag	-	-	-	-	-	-	-	-	-	-	-	-
Minimum Green [s]	0	11	0	0	8	0	0	0	0	0	4	4
Vehicle Extension [s]	0.0	0.0	0.0	0.0	0.0	0.0	0.0	0.0	0.0	0.0	0.0	0.0
Minimum Recall		Yes			Yes						No	No
Maximum Recall		No			No						No	No
Pedestrian Recall		No			No						No	No

**Exclusive Pedestrian Phase**

Pedestrian Signal Group	0
Pedestrian Walk [s]	0
Pedestrian Clearance [s]	0



**Lane Group Calculations**

Lane Group	C	C		L	C	R
C, Cycle Length [s]	105	105		105	105	105
L, Total Lost Time per Cycle [s]	4.00	4.00		4.00	4.00	4.00
l1_p, Permitted Start-Up Lost Time [s]	0.00	0.00		0.00	0.00	0.00
l2, Clearance Lost Time [s]	2.00	2.00		2.00	2.00	0.00
g_i, Effective Green Time [s]	77	89		8	8	20
g / C, Green / Cycle	0.74	0.84		0.08	0.08	0.19
(v / s)_i Volume / Saturation Flow Rate	0.19	0.06		0.02	0.02	0.07
s, saturation flow rate [veh/h]	3583	5159		1810	1810	2834
c, Capacity [veh/h]	2643	4358		143	143	554
d1, Uniform Delay [s]	4.45	1.34		45.17	45.17	36.46
k, delay calibration	0.50	0.50		0.04	0.04	0.04
l, Upstream Filtering Factor	1.00	1.00		1.00	1.00	1.00
d2, Incremental Delay [s]	0.24	0.03		0.24	0.24	0.14
d3, Initial Queue Delay [s]	0.00	0.00		0.00	0.00	0.00
Rp, platoon ratio	1.00	1.00		1.00	1.00	1.00
PF, progression factor	1.00	1.00		1.00	1.00	1.00

**Lane Group Results**

X, volume / capacity	0.26	0.07		0.19	0.19	0.36
d, Delay for Lane Group [s/veh]	4.69	1.37		45.41	45.41	36.61
Lane Group LOS	A	A		D	D	D
Critical Lane Group	Yes	No		No	No	Yes
50th-Percentile Queue Length [veh/ln]	1.89	0.13		0.66	0.66	2.12
50th-Percentile Queue Length [ft/ln]	47.34	3.33		16.49	16.49	52.88
95th-Percentile Queue Length [veh/ln]	3.41	0.24		1.19	1.19	3.81
95th-Percentile Queue Length [ft/ln]	85.21	5.99		29.68	29.68	95.18



**Movement, Approach, & Intersection Results**

d_M, Delay for Movement [s/veh]	0.00	4.69	0.00	0.00	1.37	0.00	0.00	0.00	0.00	0.00	45.41	45.41	36.61
Movement LOS		A			A						D	D	D
d_A, Approach Delay [s/veh]		3.61			0.40				0.00				38.53
Approach LOS		A			A				A				D
d_I, Intersection Delay [s/veh]	10.06												
Intersection LOS	B												
Intersection V/C	0.214												

**Emissions**

Vehicle Miles Traveled [mph]	56.64	34.32	2.70	2.70	19.38
Stops [stops/h]	129.92	13.70	22.63	22.63	145.13
Fuel consumption [US gal/h]	3.95	1.44	0.63	0.63	3.94
CO [g/h]	276.33	100.95	43.91	43.91	275.13
NOx [g/h]	53.76	19.64	8.54	8.54	53.53
VOC [g/h]	64.04	23.40	10.18	10.18	63.76

**Other Modes**

g_Walk,mi, Effective Walk Time [s]	0.0	0.0	0.0	11.0
M_corner, Corner Circulation Area [ft <sup>2</sup> /ped]	0.00	0.00	0.00	0.00
M_CW, Crosswalk Circulation Area [ft <sup>2</sup> /ped]	0.00	0.00	0.00	0.00
d_p, Pedestrian Delay [s]	0.00	0.00	0.00	42.05
I_p,int, Pedestrian LOS Score for Intersectio	0.000	0.000	0.000	2.381
Crosswalk LOS	F	F	F	B
s_b, Saturation Flow Rate of the bicycle lane	2000	2000	2000	2000
c_b, Capacity of the bicycle lane [bicycles/h]	1195	1481	0	343
d_b, Bicycle Delay [s]	8.51	3.54	52.47	36.01
I_b,int, Bicycle LOS Score for Intersection	2.120	1.719	4.132	1.975
Bicycle LOS	B	A	D	A

**Sequence**

Ring 1	1	2	-	-	-	-	-	-	-	-	-	-	-	-	-
Ring 2	-	6	-	8	-	-	-	-	-	-	-	-	-	-	-
Ring 3	-	-	-	-	-	-	-	-	-	-	-	-	-	-	-
Ring 4	-	-	-	-	-	-	-	-	-	-	-	-	-	-	-





## Appendix D: Near-Term Volume & Geometry

Lane Configuration and Traffic Control

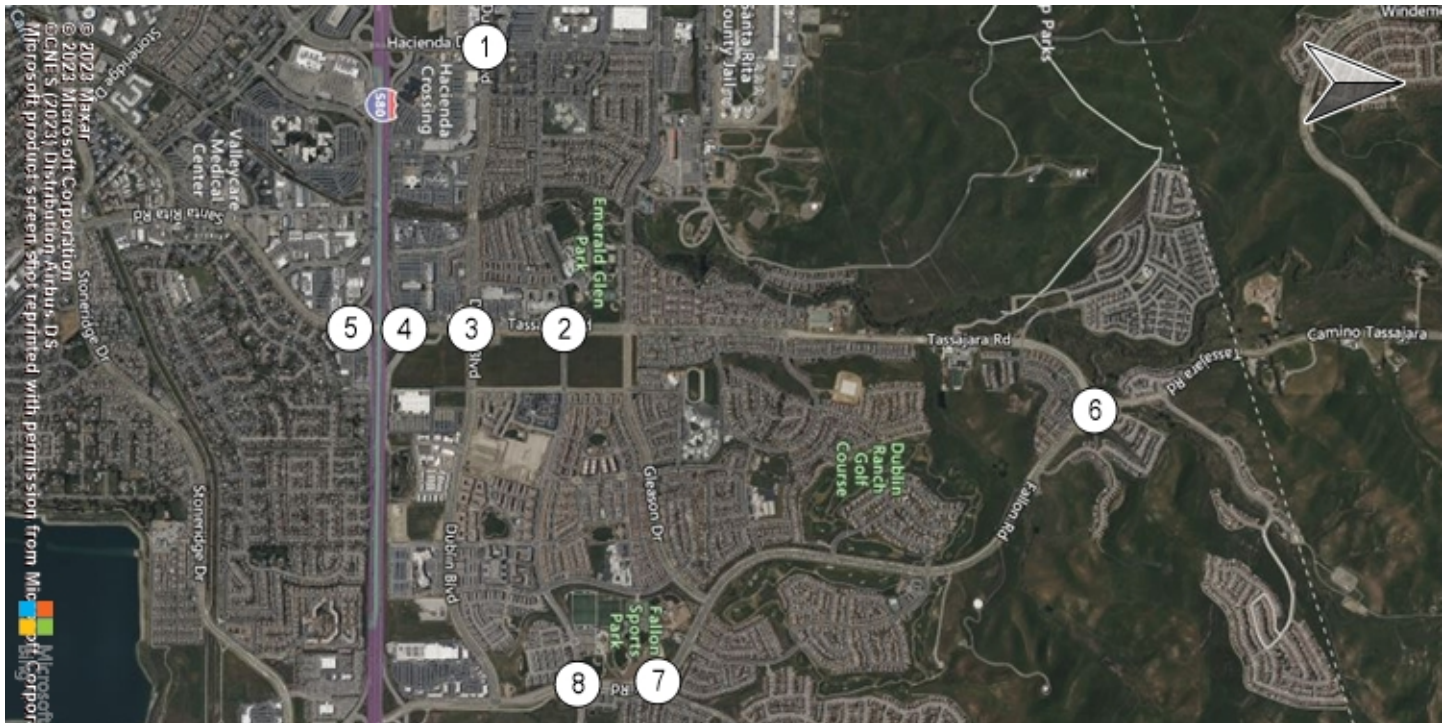

Hacienda Drive & Dublin Boul Tassajara Road & Central Pa Tassajara Road & Dublin Bou Tassajara Road & I-580 WB

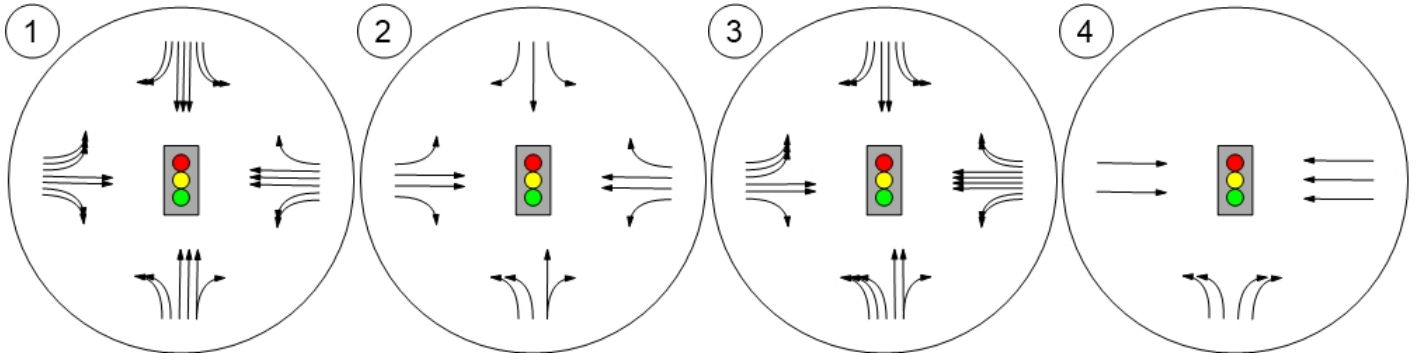

Santa Rita Rd & I-580 EB Ra Tassajara Road & Fallon Roa Fallon Road & Positano Park Fallon Road & Central Parkw

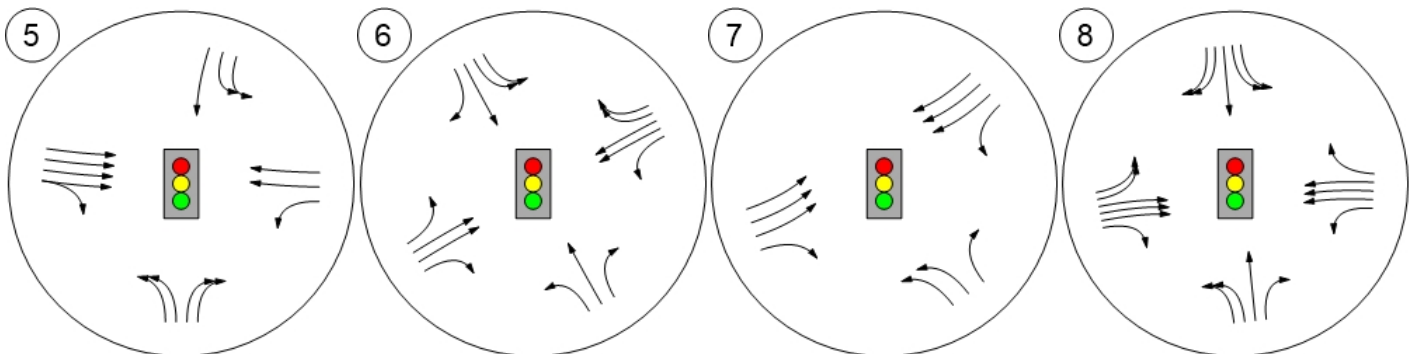



Lane Configuration and Traffic Control

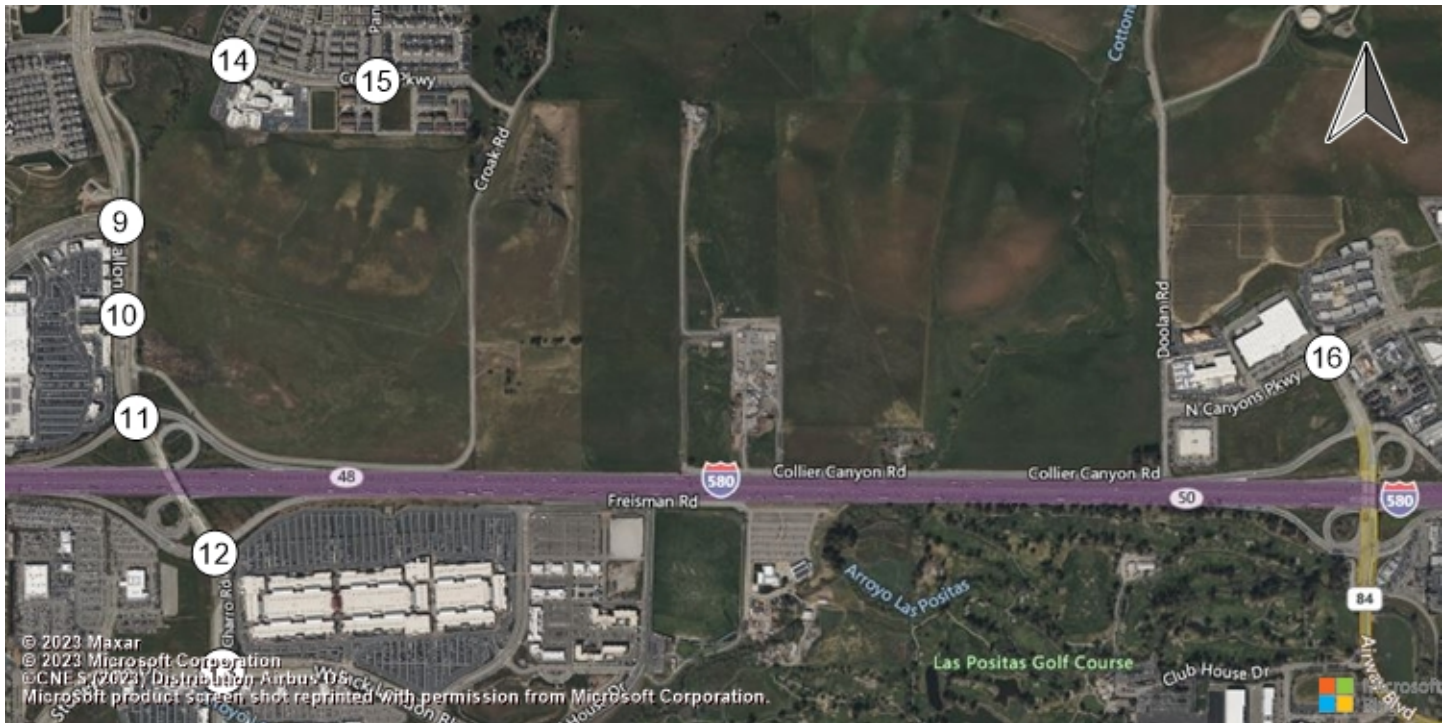

Fallon Road & Dublin Boulevard Fallon Road & Fallon Gateways Fallon Road & I-580 WB Ramp El Charro Road & I-580 EB Ramp

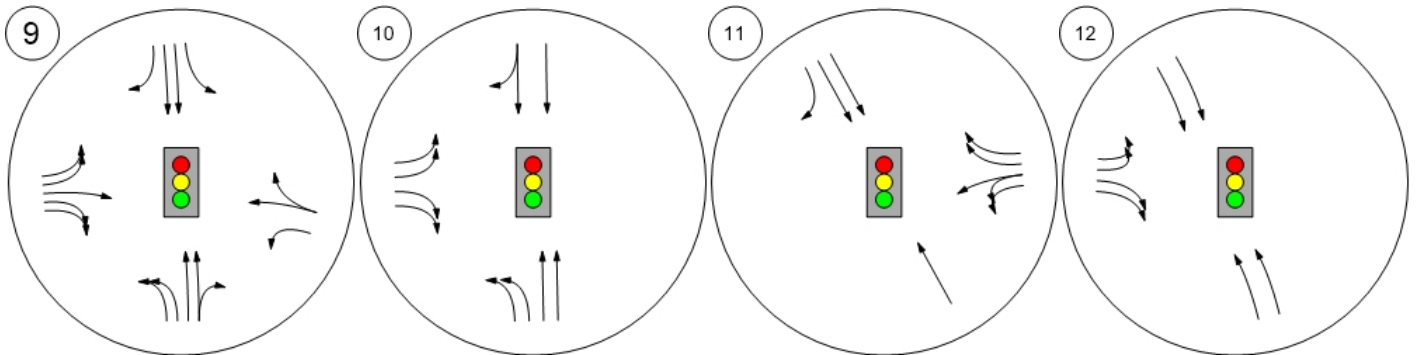

El Charro Road & Jack London Central Parkway & Sunset Vista Central Parkway & Panorama Airway Boulevard & N. Canyons Parkway

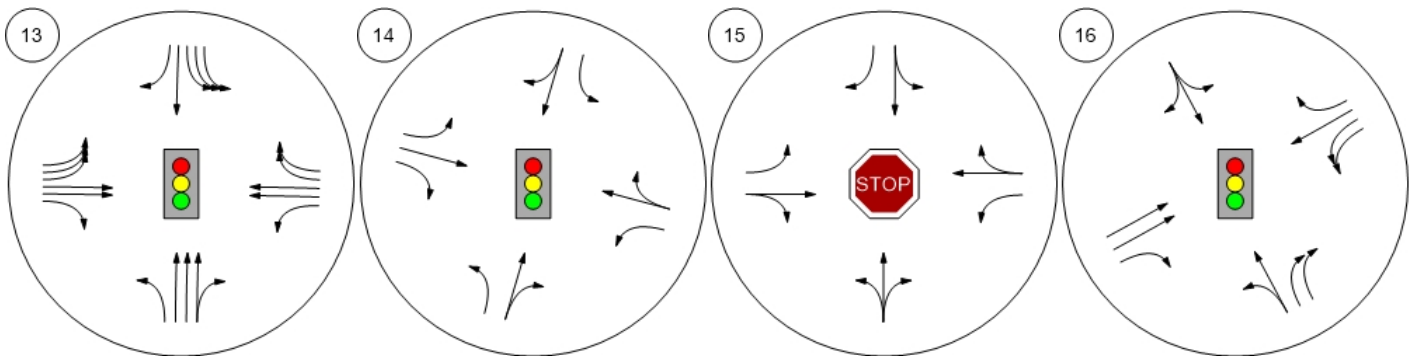



Lane Configuration and Traffic Control



Airway Boulevard & I-580 WB

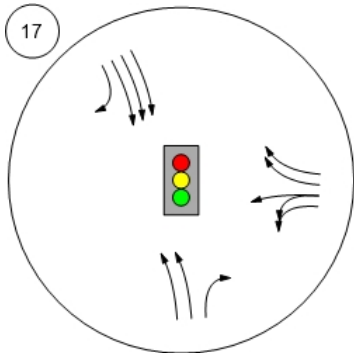

Traffic Volume - Base Volume

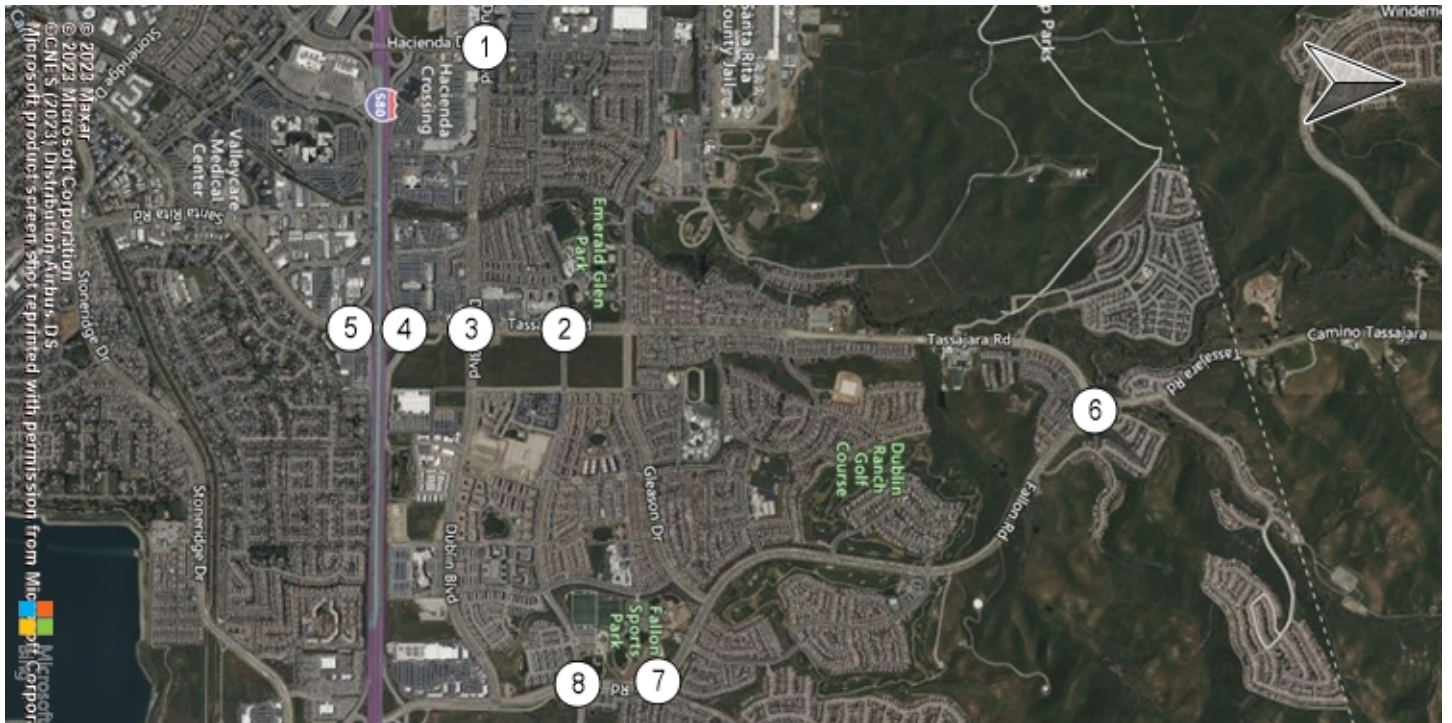

Hacienda Drive & Dublin Boul Tassajara Road & Central Pa Tassajara Road & Dublin Bou Tassajara Road & I-580 WB

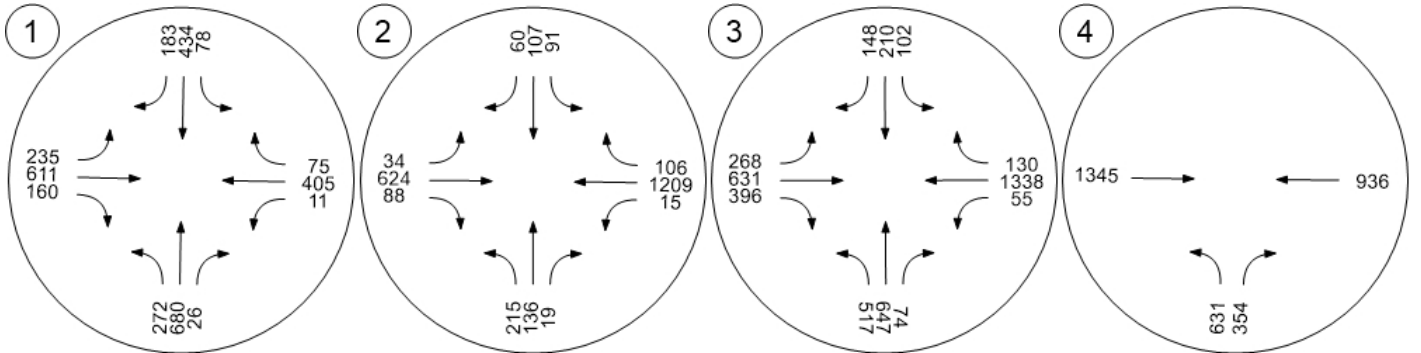

Santa Rita Rd & I-580 EB Ra Tassajara Road & Fallon Roa Fallon Road & Positano Park Fallon Road & Central Parkw

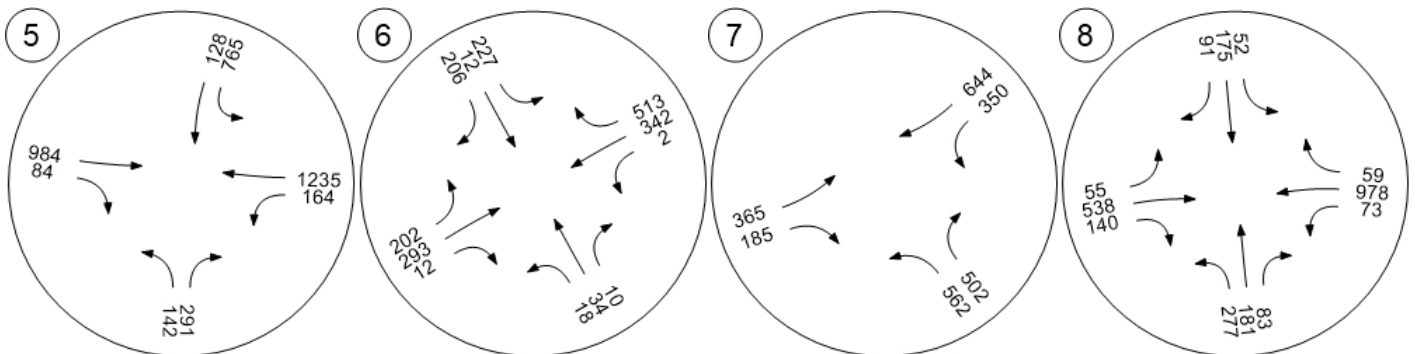



Traffic Volume - Base Volume

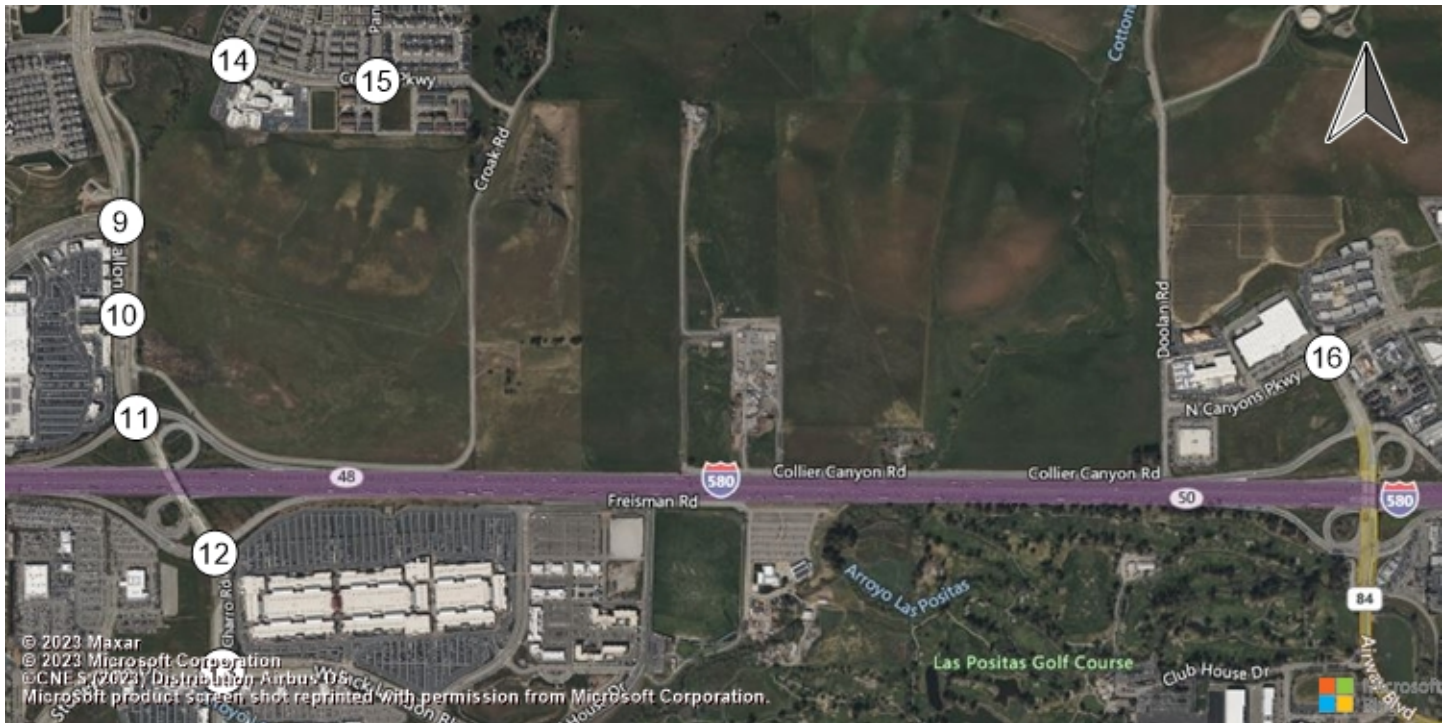

Fallon Road & Dublin Boulev Fallon Road & Fallon Gatewa Fallon Road & I-580 WB Ram El Charro Road & I-580 EB R

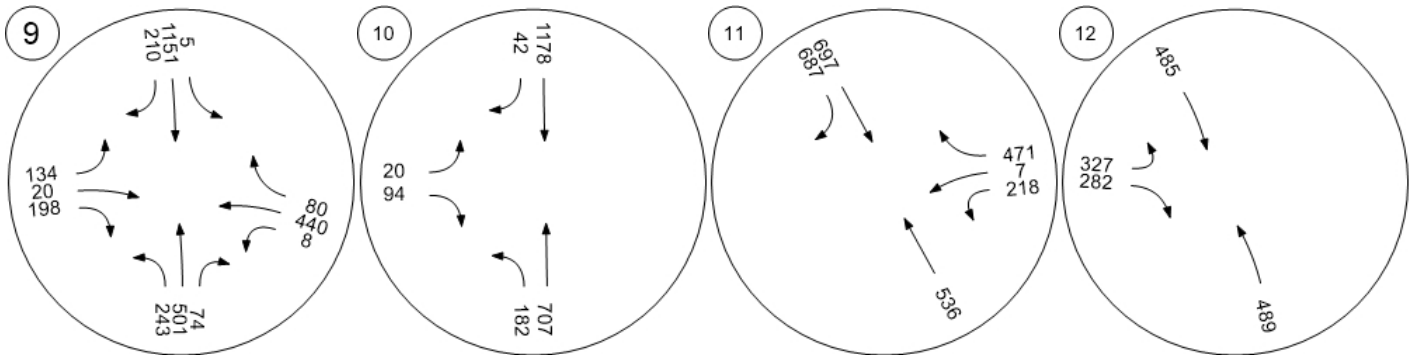

El Charro Road & Jack Lond Central Parkway & Sunset Vi Central Parkway & Panorama Airway Boulevard & N. Canyo

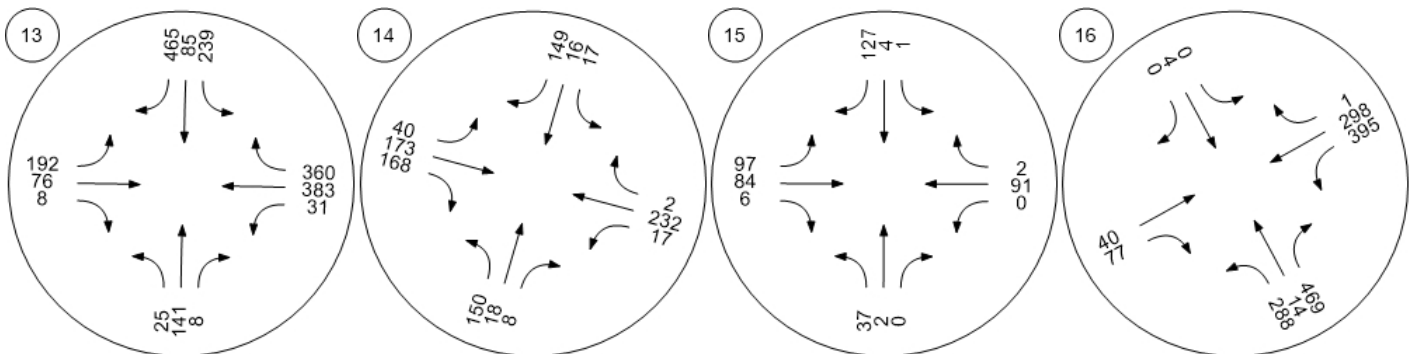

Traffic Volume - Base Volume



Airway Boulevard & I-580 WB

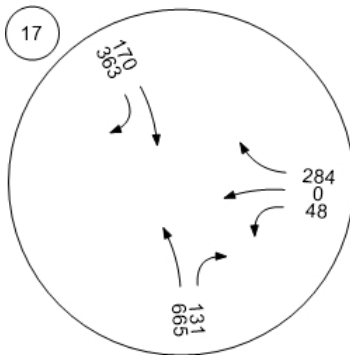



Traffic Volume - Base Volume

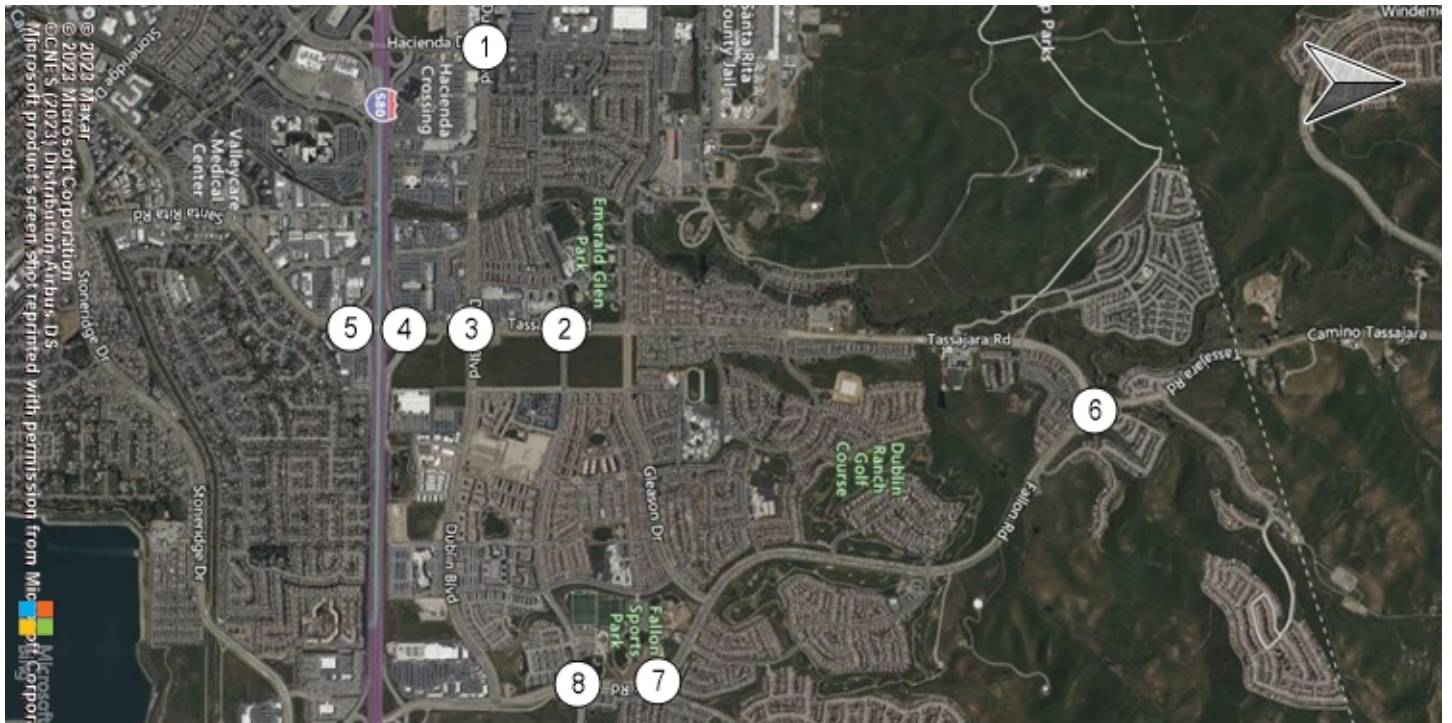

Hacienda Drive & Dublin Boul Tassajara Road & Central Pa Tassajara Road & Dublin Bou Tassajara Road & I-580 WB

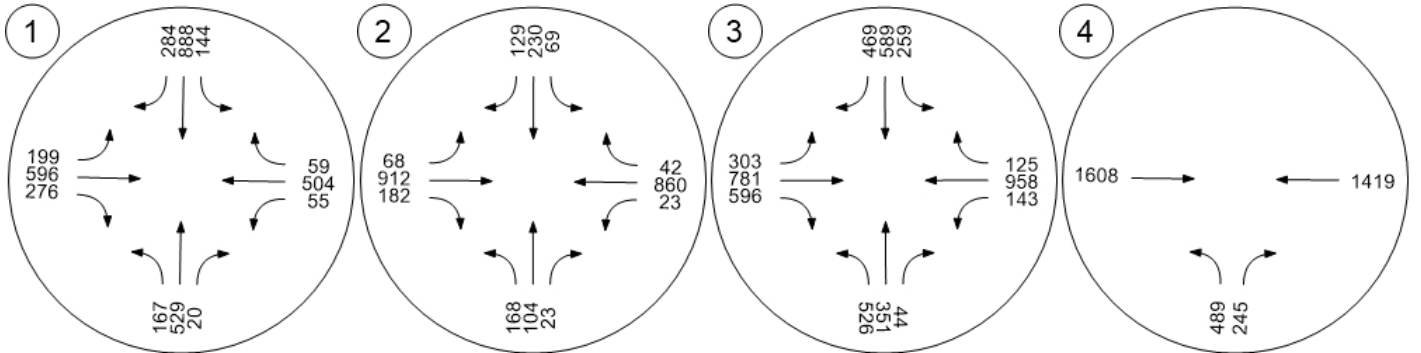

Santa Rita Rd & I-580 EB Ra Tassajara Road & Fallon Roa Fallon Road & Positano Park Fallon Road & Central Parkw

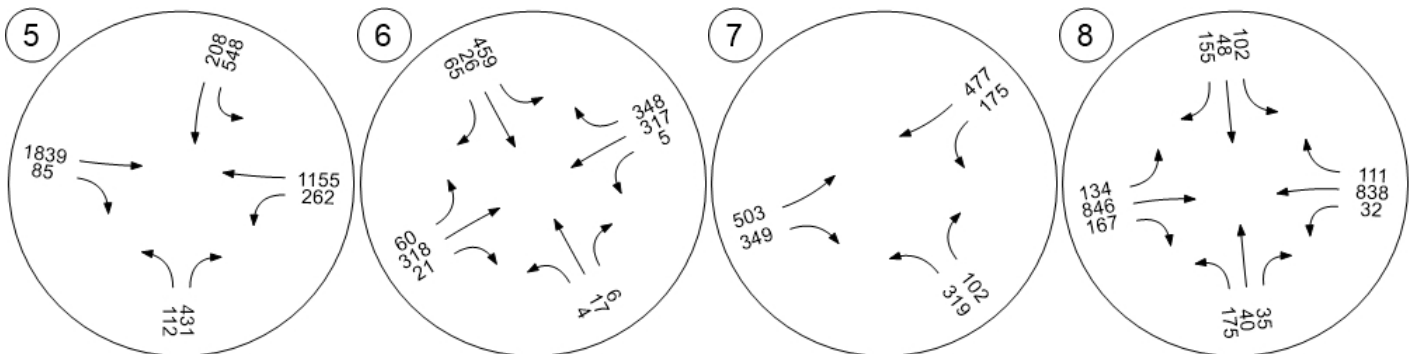

Traffic Volume - Base Volume

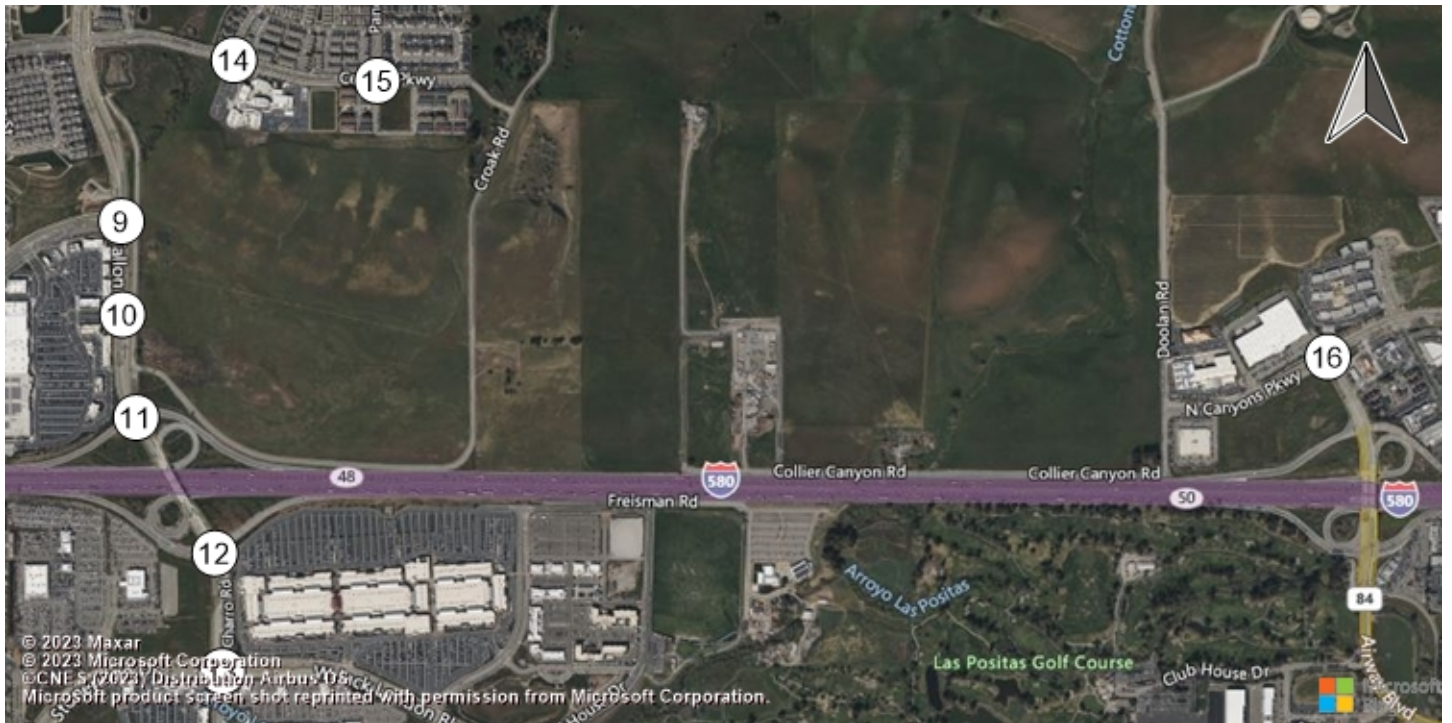

Fallon Road & Dublin Boulevard Fallon Road & Fallon Gateways Fallon Road & I-580 WB Ram El Charro Road & I-580 EB R

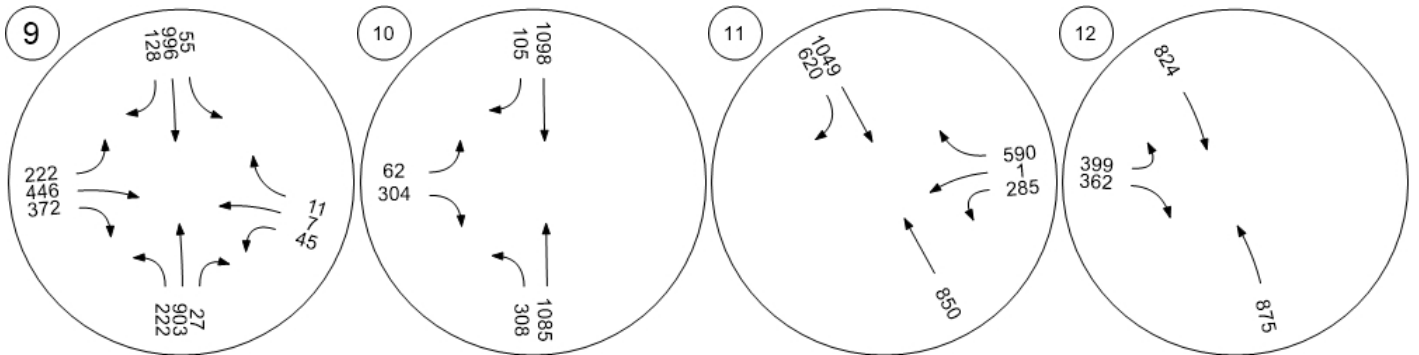

El Charro Road & Jack Lond Central Parkway & Sunset Vi Central Parkway & Panorama Airway Boulevard & N. Canyo

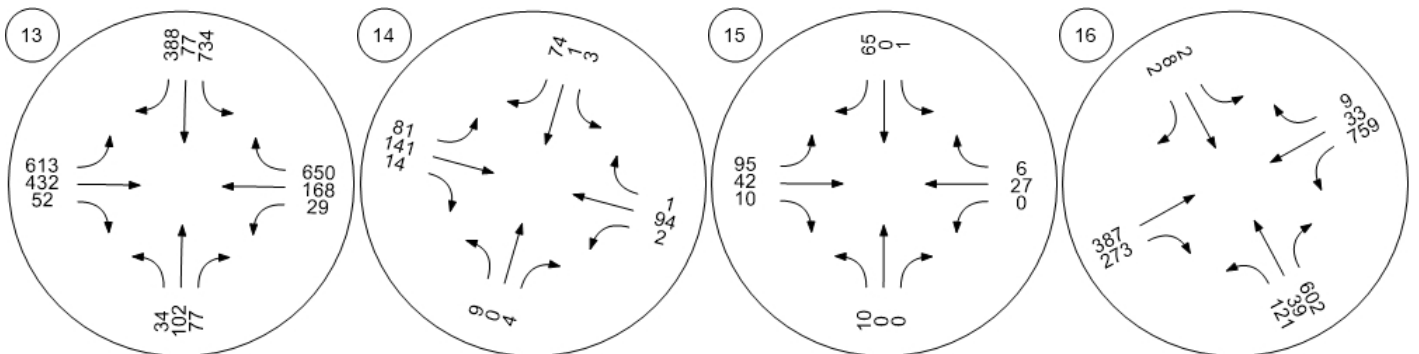



Traffic Volume - Base Volume



Airway Boulevard & I-580 WB

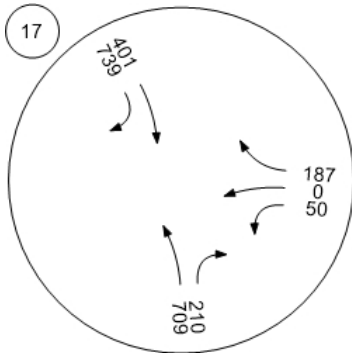



# Appendix E: Near-Term Operational Outputs



Vistro File: H:\...\PacVest\_20240229.vistro

Scenario 3 Near Term AM

Report File: H:\...\NearTermAM\_LOS.pdf

3/1/2024

**Intersection Analysis Summary**

ID	Intersection Name	Control Type	Method	Worst Mvmt	V/C	Delay (s/veh)	LOS
1	Hacienda Drive & Dublin Boulevard	Signalized	HCM 7th Edition	SB Left	0.385	41.8	D
2	Tassajara Road & Central Parkway	Signalized	HCM 7th Edition	SB Left	0.592	28.3	C
3	Tassajara Road & Dublin Boulevard	Signalized	HCM 7th Edition	WB Left	0.598	39.5	D
4	Tassajara Road & I-580 WB Ramps	Signalized	HCM 7th Edition	WB Left	0.631	13.4	B
5	Santa Rita Rd & I-580 EB Ramps/Pimlico Dr	Signalized	HCM 7th Edition	SB Left	0.753	32.5	C
6	Tassajara Road & Fallon Road	Signalized	HCM 7th Edition	SB Left	0.666	22.8	C
7	Fallon Road & Positano Parkway	Signalized	HCM 7th Edition	WB Right	0.857	31.3	C
8	Fallon Road & Central Parkway	Signalized	HCM 7th Edition	SB Left	0.572	32.1	C
9	Fallon Road & Dublin Boulevard	Signalized	HCM 7th Edition	WB Left	0.545	23.2	C
10	Fallon Road & Fallon Gateway	Signalized	HCM 7th Edition	NB Left	0.527	13.1	B
11	Fallon Road & I-580 WB Ramps	Signalized	HCM 7th Edition	WB Left	0.750	8.7	A
12	El Charro Road & I-580 EB Ramps	Signalized	HCM 7th Edition	EB Right	0.434	6.8	A
13	El Charro Road & Jack London Boulevard	Signalized	HCM 7th Edition	WB Left	0.417	13.8	B
14	Central Parkway & Sunset View Drive	Signalized	HCM 7th Edition	EB Right	0.764	31.6	C
15	Central Parkway & Panorama Drive/Pino Grande Road	All-way stop	HCM 7th Edition	EB Left	0.359	11.0	B
16	Airway Boulevard & N. Canyons Parkway	Signalized	HCM 7th Edition	SB Thru	0.436	17.8	B
17	Airway Boulevard & I-580 WB Ramps	Signalized	HCM 7th Edition	WB Left	0.253	13.5	B



V/C, Delay, LOS: For two-way stop, these values are taken from the movement with the worst (highest) delay value. For all other control types, they are taken for the whole intersection.

**Intersection Level Of Service Report**  
**Intersection 1: Hacienda Drive & Dublin Boulevard**

Control Type:	Signalized	Delay (sec / veh):	41.8
Analysis Method:	HCM 7th Edition	Level Of Service:	D
Analysis Period:	15 minutes	Volume to Capacity (v/c):	0.385

**Intersection Setup**

Name	Hacienda Drive			Hacienda Drive			Dublin Boulevard			Dublin Boulevard		
Approach	Northbound			Southbound			Eastbound			Westbound		
Lane Configuration	[Diagram]			[Diagram]			[Diagram]			[Diagram]		
Turning Movement	Left	Thru	Right	Left	Thru	Right	Left	Thru	Right	Left	Thru	Right
Lane Width [ft]	12.00	12.00	12.00	12.00	12.00	12.00	12.00	12.00	12.00	12.00	12.00	12.00
No. of Lanes in Entry Pocket	2	0	2	2	0	1	2	0	2	2	0	0
Entry Pocket Length [ft]	250.00	100.00	380.00	300.00	100.00	220.00	300.00	100.00	250.00	275.00	100.00	100.00
No. of Lanes in Exit Pocket	0	0	0	0	0	0	0	0	0	0	0	1
Exit Pocket Length [ft]	0.00	0.00	0.00	0.00	0.00	0.00	0.00	0.00	0.00	0.00	0.00	1000.00
Speed [mph]	35.00			35.00			40.00			40.00		
Grade [%]	0.00			0.00			0.00			0.00		
Curb Present	Yes			Yes			Yes			Yes		
Crosswalk	Yes			Yes			Yes			Yes		



**Volumes**

Name	Hacienda Drive			Hacienda Drive			Dublin Boulevard			Dublin Boulevard		
Base Volume Input [veh/h]	235	611	160	11	405	75	78	434	183	272	680	26
Base Volume Adjustment Factor	1.0000	1.0000	1.0000	1.0000	1.0000	1.0000	1.0000	1.0000	1.0000	1.0000	1.0000	1.0000
Heavy Vehicles Percentage [%]	3.40	1.10	1.90	0.00	1.50	4.50	5.20	1.70	8.60	0.50	2.30	4.80
Proportion of CAVs [%]	0.00											
Growth Factor	1.0000	1.0000	1.0000	1.0000	1.0000	1.0000	1.0000	1.0000	1.0000	1.0000	1.0000	1.0000
In-Process Volume [veh/h]	0	0	0	0	0	0	0	0	0	0	0	0
Site-Generated Trips [veh/h]	0	0	0	0	0	0	0	0	0	0	0	0
Diverted Trips [veh/h]	0	0	0	0	0	0	0	0	0	0	0	0
Pass-by Trips [veh/h]	0	0	0	0	0	0	0	0	0	0	0	0
Existing Site Adjustment Volume [veh/h]	0	0	0	0	0	0	0	0	0	0	0	0
Other Volume [veh/h]	0	0	0	0	0	0	0	0	0	0	0	0
Right Turn on Red Volume [veh/h]	0	0	0	0	0	0	0	0	0	0	0	0
Total Hourly Volume [veh/h]	235	611	160	11	405	75	78	434	183	272	680	26
Peak Hour Factor	0.9500	0.9500	0.9500	0.9500	0.9500	0.9500	0.9500	0.9500	0.9500	0.9500	0.9500	0.9500
Other Adjustment Factor	1.0000	1.0000	1.0000	1.0000	1.0000	1.0000	1.0000	1.0000	1.0000	1.0000	1.0000	1.0000
Total 15-Minute Volume [veh/h]	62	161	42	3	107	20	21	114	48	72	179	7
Total Analysis Volume [veh/h]	247	643	168	12	426	79	82	457	193	286	716	27
Presence of On-Street Parking	No		No	No		No	No		No	No		No
On-Street Parking Maneuver Rate [/h]	0	0	0	0	0	0	0	0	0	0	0	0
Local Bus Stopping Rate [/h]	0	0	0	0	0	0	0	0	0	0	0	0
v_do, Outbound Pedestrian Volume crossing	1			3			0			2		
v_di, Inbound Pedestrian Volume crossing m	0			2			1			3		
v_co, Outbound Pedestrian Volume crossing	0			2			3			1		
v_ci, Inbound Pedestrian Volume crossing mi	1			3			2			0		
v_ab, Corner Pedestrian Volume [ped/h]	0			0			0			0		
Bicycle Volume [bicycles/h]	0			0			0			1		



**Intersection Settings**

Located in CBD	No
Signal Coordination Group	-
Cycle Length [s]	150
Active Pattern	Pattern 1
Coordination Type	Time of Day Pattern Coordinated
Actuation Type	Fully actuated
Offset [s]	57.0
Offset Reference	Lead Green - Beginning of First Green
Permissive Mode	SingleBand
Lost time [s]	12.00

**Phasing & Timing (Basic)**

Control Type	Protecte	Permiss	Permiss	Protecte	Permiss	Permiss	Protecte	Permiss	Permiss	Protecte	Permiss	Permiss
Signal Group	3	8	0	7	4	0	5	2	0	1	6	0
Auxiliary Signal Groups												
Maximum Green [s]	20	50	0	20	50	0	20	60	0	20	60	0
Amber [s]	3.5	4.5	0.0	3.5	4.1	0.0	3.5	4.5	0.0	3.5	4.5	0.0
All red [s]	1.5	1.5	0.0	1.0	1.5	0.0	1.0	1.5	0.0	1.0	1.5	0.0
Walk [s]	0	4	0	0	4	0	0	4	0	0	4	0
Pedestrian Clearance [s]	0	32	0	0	40	0	0	43	0	0	35	0
Delayed Vehicle Green [s]	0.0	0.0	0.0	0.0	0.0	0.0	0.0	0.0	0.0	0.0	0.0	0.0
Rest In Walk		No			No			No			No	
I1, Start-Up Lost Time [s]	2.0	2.0	0.0	2.0	2.0	0.0	2.0	2.0	0.0	2.0	2.0	0.0
I2, Clearance Lost Time [s]	2.0	2.0	0.0	2.0	2.0	0.0	2.0	2.0	0.0	2.0	2.0	0.0
Detector Location [ft]	0.0	0.0	0.0	0.0	0.0	0.0	0.0	0.0	0.0	0.0	0.0	0.0
Detector Length [ft]	20.0	20.0	0.0	20.0	20.0	0.0	20.0	20.0	0.0	20.0	20.0	0.0
I, Upstream Filtering Factor	1.00	1.00	1.00	1.00	1.00	1.00	1.00	1.00	1.00	1.00	1.00	1.00

**Phasing & Timing: Pattern 1**

Split [s]	18	55	0	14	51	0	15	61	0	20	66	0
Lead / Lag	Lead	-	-	Lead	-	-	Lead	-	-	Lead	-	-
Minimum Green [s]	4	10	0	4	10	0	4	10	0	8	10	0
Vehicle Extension [s]	3.0	3.5	0.0	3.0	3.5	0.0	3.0	3.5	0.0	3.0	3.5	0.0
Minimum Recall	No	No		No	No		No	Yes		No	Yes	
Maximum Recall	No	No		No	No		No	No		No	No	
Pedestrian Recall	No	No		No	No		No	No		No	No	

**Exclusive Pedestrian Phase**

Pedestrian Signal Group	0
Pedestrian Walk [s]	0
Pedestrian Clearance [s]	0



**Lane Group Calculations**

Lane Group	L	C	R	L	C	R	L	C	R	L	C	C
C, Cycle Length [s]	150	150	150	150	150	150	150	150	150	150	150	150
L, Total Lost Time per Cycle [s]	4.00	4.00	4.00	4.00	4.00	4.00	4.00	4.00	4.00	4.00	4.00	4.00
l1_p, Permitted Start-Up Lost Time [s]	0.00	0.00	0.00	0.00	0.00	0.00	0.00	0.00	0.00	0.00	0.00	0.00
l2, Clearance Lost Time [s]	2.00	2.00	2.00	2.00	2.00	2.00	2.00	2.00	2.00	2.00	2.00	2.00
g_i, Effective Green Time [s]	10	33	33	2	25	25	6	84	84	15	93	93
g / C, Green / Cycle	0.07	0.22	0.22	0.01	0.17	0.17	0.04	0.56	0.56	0.10	0.62	0.62
(v / s)_i Volume / Saturation Flow Rate	0.05	0.18	0.06	0.00	0.08	0.05	0.02	0.09	0.07	0.08	0.14	0.14
s, saturation flow rate [veh/h]	5130	3586	2812	3514	5114	1544	3370	5106	2663	3500	3552	1828
c, Capacity [veh/h]	356	795	624	50	852	257	136	2855	1489	344	2192	1128
d1, Uniform Delay [s]	68.26	55.37	48.33	73.16	56.85	54.90	70.85	16.02	15.73	66.46	12.77	12.77
k, delay calibration	0.11	0.13	0.13	0.11	0.13	0.13	0.11	0.50	0.50	0.11	0.50	0.50
l, Upstream Filtering Factor	1.00	1.00	1.00	1.00	1.00	1.00	1.00	1.00	1.00	1.00	1.00	1.00
d2, Incremental Delay [s]	2.42	2.42	0.28	2.40	0.55	0.81	4.29	0.12	0.18	5.24	0.24	0.46
d3, Initial Queue Delay [s]	0.00	0.00	0.00	0.00	0.00	0.00	0.00	0.00	0.00	0.00	0.00	0.00
Rp, platoon ratio	1.00	1.00	1.00	1.00	1.00	1.00	1.00	1.00	1.00	1.00	1.00	1.00
PF, progression factor	1.00	1.00	1.00	1.00	1.00	1.00	1.00	1.00	1.00	1.00	1.00	1.00

**Lane Group Results**

X, volume / capacity	0.69	0.81	0.27	0.24	0.50	0.31	0.60	0.16	0.13	0.83	0.22	0.22
d, Delay for Lane Group [s/veh]	70.68	57.79	48.61	75.56	57.40	55.71	75.13	16.15	15.91	71.69	13.00	13.24
Lane Group LOS	E	E	D	E	E	E	E	B	B	E	B	B
Critical Lane Group	No	Yes	No	Yes	No	No	No	Yes	No	Yes	No	No
50th-Percentile Queue Length [veh/ln]	3.17	11.76	2.64	0.25	4.94	2.69	1.62	2.54	1.60	5.58	3.65	3.84
50th-Percentile Queue Length [ft/ln]	79.15	293.94	66.10	6.14	123.59	67.26	40.54	63.61	39.99	139.60	91.32	96.10
95th-Percentile Queue Length [veh/ln]	5.70	17.38	4.76	0.44	8.59	4.84	2.92	4.58	2.88	9.46	6.57	6.92
95th-Percentile Queue Length [ft/ln]	142.47	434.52	118.99	11.05	214.75	121.06	72.98	114.50	71.98	236.49	164.37	172.99



**Movement, Approach, & Intersection Results**

d_M, Delay for Movement [s/veh]	70.68	57.79	48.61	75.56	57.40	55.71	75.13	16.15	15.91	71.69	13.08	13.24
Movement LOS	E	E	D	E	E	E	E	B	B	E	B	B
d_A, Approach Delay [s/veh]	59.34			57.56			22.69			29.37		
Approach LOS	E			E			C			C		
d_I, Intersection Delay [s/veh]	41.78											
Intersection LOS	D											
Intersection V/C	0.385											

**Emissions**

Vehicle Miles Traveled [mph]	25.07	65.25	17.05	1.40	49.58	9.20	9.37	52.23	22.06	251.49	430.86	222.47
Stops [stops/h]	227.88	564.21	126.88	11.78	355.83	64.55	77.82	183.15	76.76	267.96	175.28	92.24
Fuel consumption [US gal/h]	6.22	14.29	3.27	0.33	9.54	1.73	2.35	5.17	2.17	15.81	18.45	9.56
CO [g/h]	434.88	999.01	228.27	22.81	666.95	121.02	164.53	361.50	151.62	1105.31	1289.82	668.00
NOx [g/h]	84.61	194.37	44.41	4.44	129.76	23.55	32.01	70.34	29.50	215.05	250.95	129.97
VOC [g/h]	100.79	231.53	52.90	5.29	154.57	28.05	38.13	83.78	35.14	256.17	298.93	154.82

**Other Modes**

g_Walk,mi, Effective Walk Time [s]	8.0			8.0			8.0			8.0		
M_corner, Corner Circulation Area [ft <sup>2</sup> /ped]	0.00			0.00			0.00			0.00		
M_CW, Crosswalk Circulation Area [ft <sup>2</sup> /ped]	3359.36			922.42			857.57			3179.53		
d_p, Pedestrian Delay [s]	67.23			67.23			67.23			67.23		
I_p,int, Pedestrian LOS Score for Intersectio	3.216			2.932			3.223			3.022		
Crosswalk LOS	C			C			C			C		
s_b, Saturation Flow Rate of the bicycle lane	2000			2000			2000			2000		
c_b, Capacity of the bicycle lane [bicycles/h]	653			605			733			800		
d_b, Bicycle Delay [s]	34.02			36.49			30.10			27.03		
I_b,int, Bicycle LOS Score for Intersection	2.432			1.844			1.962			2.126		
Bicycle LOS	B			A			A			B		

**Sequence**

Ring 1	1	2	3	4	-	-	-	-	-	-	-	-	-	-	-
Ring 2	5	6	7	8	-	-	-	-	-	-	-	-	-	-	-
Ring 3	-	-	-	-	-	-	-	-	-	-	-	-	-	-	-
Ring 4	-	-	-	-	-	-	-	-	-	-	-	-	-	-	-

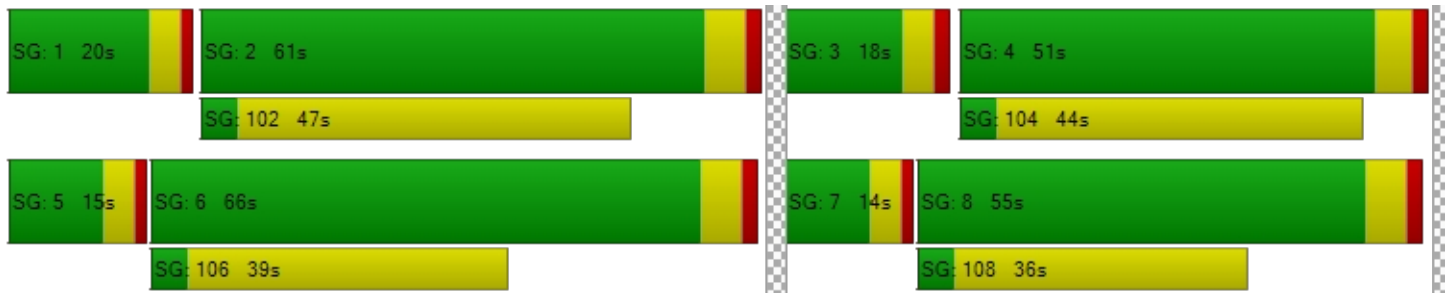

**Intersection Level Of Service Report**  
**Intersection 2: Tassajara Road & Central Parkway**

Control Type:	Signalized	Delay (sec / veh):	28.3
Analysis Method:	HCM 7th Edition	Level Of Service:	C
Analysis Period:	15 minutes	Volume to Capacity (v/c):	0.592

**Intersection Setup**

Name	Tassajara Road			Tassajara Road			Central Parkway			Central Parkway		
Approach	Northbound			Southbound			Eastbound			Westbound		
Lane Configuration												
Turning Movement	Left	Thru	Right	Left	Thru	Right	Left	Thru	Right	Left	Thru	Right
Lane Width [ft]	12.00	12.00	12.00	12.00	12.00	12.00	12.00	12.00	12.00	12.00	12.00	12.00
No. of Lanes in Entry Pocket	1	0	1	1	0	1	1	0	1	2	0	0
Entry Pocket Length [ft]	325.00	100.00	325.00	300.00	100.00	215.00	225.00	100.00	225.00	300.00	100.00	100.00
No. of Lanes in Exit Pocket	0	0	0	0	0	0	0	0	0	0	0	0
Exit Pocket Length [ft]	0.00	0.00	0.00	0.00	0.00	0.00	0.00	0.00	0.00	0.00	0.00	0.00
Speed [mph]	40.00			40.00			35.00			35.00		
Grade [%]	0.00			0.00			0.00			0.00		
Curb Present	Yes			Yes			Yes			Yes		
Crosswalk	Yes			Yes			Yes			Yes		





**Volumes**

Name	Tassajara Road			Tassajara Road			Central Parkway			Central Parkway		
Base Volume Input [veh/h]	34	624	88	15	1209	106	91	107	60	215	136	19
Base Volume Adjustment Factor	1.0000	1.0000	1.0000	1.0000	1.0000	1.0000	1.0000	1.0000	1.0000	1.0000	1.0000	1.0000
Heavy Vehicles Percentage [%]	0.00	2.00	8.50	0.00	0.70	2.10	1.10	0.00	1.70	0.90	0.00	0.00
Proportion of CAVs [%]	0.00											
Growth Factor	1.0000	1.0000	1.0000	1.0000	1.0000	1.0000	1.0000	1.0000	1.0000	1.0000	1.0000	1.0000
In-Process Volume [veh/h]	0	0	0	0	0	0	0	0	0	0	0	0
Site-Generated Trips [veh/h]	0	0	0	0	0	0	0	0	0	0	0	0
Diverted Trips [veh/h]	0	0	0	0	0	0	0	0	0	0	0	0
Pass-by Trips [veh/h]	0	0	0	0	0	0	0	0	0	0	0	0
Existing Site Adjustment Volume [veh/h]	0	0	0	0	0	0	0	0	0	0	0	0
Other Volume [veh/h]	0	0	0	0	0	0	0	0	0	0	0	0
Right Turn on Red Volume [veh/h]	0	0	0	0	0	0	0	0	0	0	0	0
Total Hourly Volume [veh/h]	34	624	88	15	1209	106	91	107	60	215	136	19
Peak Hour Factor	0.9100	0.9100	0.9100	0.9100	0.9100	0.9100	0.9100	0.9100	0.9100	0.9100	0.9100	0.9100
Other Adjustment Factor	1.0000	1.0000	1.0000	1.0000	1.0000	1.0000	1.0000	1.0000	1.0000	1.0000	1.0000	1.0000
Total 15-Minute Volume [veh/h]	9	171	24	4	332	29	25	29	16	59	37	5
Total Analysis Volume [veh/h]	37	686	97	16	1329	116	100	118	66	236	149	21
Presence of On-Street Parking	No		No	No		No	No		No	No		No
On-Street Parking Maneuver Rate [/h]	0	0	0	0	0	0	0	0	0	0	0	0
Local Bus Stopping Rate [/h]	0	0	0	0	0	0	0	0	0	0	0	0
v_do, Outbound Pedestrian Volume crossing	2			2			1			2		
v_di, Inbound Pedestrian Volume crossing m	1			2			2			2		
v_co, Outbound Pedestrian Volume crossing	1			6			7			2		
v_ci, Inbound Pedestrian Volume crossing mi	2			7			6			1		
v_ab, Corner Pedestrian Volume [ped/h]	0			0			0			0		
Bicycle Volume [bicycles/h]	0			0			0			12		



**Intersection Settings**

Located in CBD	No
Signal Coordination Group	-
Cycle Length [s]	130
Active Pattern	Pattern 1
Coordination Type	Time of Day Pattern Coordinated
Actuation Type	Fully actuated
Offset [s]	20.0
Offset Reference	Lead Green - Beginning of First Green
Permissive Mode	SingleBand
Lost time [s]	12.00

**Phasing & Timing (Basic)**

Control Type	Protecte	Permiss	Permiss	Protecte	Permiss	Permiss	Protecte	Permiss	Permiss	Protecte	Permiss	Permiss
Signal Group	3	8	0	7	4	0	5	2	0	1	6	0
Auxiliary Signal Groups												
Maximum Green [s]	20	40	0	20	40	0	20	20	0	20	20	0
Amber [s]	3.5	4.3	0.0	3.5	4.3	0.0	3.5	4.1	0.0	3.5	4.1	0.0
All red [s]	1.0	1.0	0.0	1.0	1.0	0.0	1.0	1.0	0.0	1.0	1.0	0.0
Walk [s]	0	4	0	0	4	0	0	4	0	0	4	0
Pedestrian Clearance [s]	0	20	0	0	24	0	0	36	0	0	30	0
Delayed Vehicle Green [s]	0.0	0.0	0.0	0.0	0.0	0.0	0.0	0.0	0.0	0.0	0.0	0.0
Rest In Walk		No			No			No			No	
I1, Start-Up Lost Time [s]	2.0	2.0	0.0	2.0	2.0	0.0	2.0	2.0	0.0	2.0	2.0	0.0
I2, Clearance Lost Time [s]	2.5	3.3	0.0	2.5	3.3	0.0	2.5	3.1	0.0	2.5	3.1	0.0
Detector Location [ft]	0.0	0.0	0.0	0.0	0.0	0.0	0.0	0.0	0.0	0.0	0.0	0.0
Detector Length [ft]	20.0	20.0	0.0	20.0	20.0	0.0	20.0	20.0	0.0	20.0	20.0	0.0
I, Upstream Filtering Factor	1.00	1.00	1.00	1.00	1.00	1.00	1.00	1.00	1.00	1.00	1.00	1.00

**Phasing & Timing: Pattern 1**

Split [s]	18	48	0	18	48	0	23	45	0	19	41	0
Lead / Lag	Lead	-	-	Lead	-	-	Lead	-	-	Lead	-	-
Minimum Green [s]	13	12	0	13	12	0	13	13	0	14	13	0
Vehicle Extension [s]	2.5	4.0	0.0	2.5	4.0	0.0	2.5	2.5	0.0	2.5	2.5	0.0
Minimum Recall	No	Yes		No	Yes		No	No		No	No	
Maximum Recall	No	No		No	No		No	No		No	No	
Pedestrian Recall	No	No		No	No		No	No		No	No	

**Exclusive Pedestrian Phase**

Pedestrian Signal Group	0
Pedestrian Walk [s]	0
Pedestrian Clearance [s]	0



**Lane Group Calculations**

Lane Group	L	C	R	L	C	R	L	C	R	L	C
C, Cycle Length [s]	130	130	130	130	130	130	130	130	130	130	130
L, Total Lost Time per Cycle [s]	4.50	5.30	5.30	4.50	5.30	5.30	4.50	5.10	5.10	4.50	5.10
l1_p, Permitted Start-Up Lost Time [s]	0.00	0.00	0.00	0.00	0.00	0.00	0.00	0.00	0.00	0.00	0.00
l2, Clearance Lost Time [s]	2.50	3.30	3.30	2.50	3.30	3.30	2.50	3.10	3.10	2.50	3.10
g_i, Effective Green Time [s]	10	76	76	6	73	73	13	14	14	14	16
g / C, Green / Cycle	0.07	0.59	0.59	0.04	0.56	0.56	0.10	0.11	0.11	0.11	0.12
(v / s)_i Volume / Saturation Flow Rate	0.02	0.19	0.06	0.01	0.37	0.07	0.06	0.06	0.04	0.07	0.09
s, saturation flow rate [veh/h]	1810	3560	1503	1810	3598	1570	1794	1900	1580	3489	1848
c, Capacity [veh/h]	134	2091	883	80	2006	875	175	211	176	376	225
d1, Uniform Delay [s]	56.88	13.70	11.83	59.88	20.16	13.72	56.05	54.73	53.55	55.47	55.22
k, delay calibration	0.08	0.50	0.50	0.08	0.50	0.50	0.08	0.08	0.08	0.08	0.08
l, Upstream Filtering Factor	1.00	1.00	1.00	1.00	1.00	1.00	1.00	1.00	1.00	1.00	1.00
d2, Incremental Delay [s]	0.82	0.42	0.25	0.90	1.74	0.31	2.18	1.71	0.98	1.28	3.86
d3, Initial Queue Delay [s]	0.00	0.00	0.00	0.00	0.00	0.00	0.00	0.00	0.00	0.00	0.00
Rp, platoon ratio	1.00	1.00	1.00	1.00	1.00	1.00	1.00	1.00	1.00	1.00	1.00
PF, progression factor	1.00	1.00	1.00	1.00	1.00	1.00	1.00	1.00	1.00	1.00	1.00

**Lane Group Results**

X, volume / capacity	0.28	0.33	0.11	0.20	0.66	0.13	0.57	0.56	0.38	0.63	0.76
d, Delay for Lane Group [s/veh]	57.71	14.12	12.08	60.78	21.90	14.03	58.22	56.44	54.53	56.75	59.08
Lane Group LOS	E	B	B	E	C	B	E	E	D	E	E
Critical Lane Group	Yes	No	No	No	Yes	No	Yes	No	No	No	Yes
50th-Percentile Queue Length [veh/ln]	1.17	5.03	1.26	0.52	13.78	1.66	3.23	3.75	2.04	3.75	5.60
50th-Percentile Queue Length [ft/ln]	29.19	125.68	31.47	13.08	344.61	41.39	80.69	93.67	51.09	93.75	139.93
95th-Percentile Queue Length [veh/ln]	2.10	8.70	2.27	0.94	19.87	2.98	5.81	6.74	3.68	6.75	9.48
95th-Percentile Queue Length [ft/ln]	52.54	217.61	56.64	23.55	496.84	74.51	145.24	168.61	91.96	168.76	236.93



**Movement, Approach, & Intersection Results**

d_M, Delay for Movement [s/veh]	57.71	14.12	12.08	60.78	21.90	14.03	58.22	56.44	54.53	56.75	59.08	59.08
Movement LOS	E	B	B	E	C	B	E	E	D	E	E	E
d_A, Approach Delay [s/veh]	15.85			21.70			56.62			57.72		
Approach LOS	B			C			E			E		
d_I, Intersection Delay [s/veh]	28.35											
Intersection LOS	C											
Intersection V/C	0.592											

**Emissions**

Vehicle Miles Traveled [mph]	10.67	197.83	27.97	3.04	252.81	22.07	13.16	15.53	8.69	32.00	23.05
Stops [stops/h]	32.34	278.47	34.86	14.49	763.57	45.86	89.39	103.78	56.60	207.73	155.02
Fuel consumption [US gal/h]	1.13	11.79	1.58	0.45	22.48	1.57	2.36	2.73	1.49	5.51	4.09
CO [g/h]	79.29	824.39	110.64	31.40	1571.41	109.89	164.87	190.65	104.08	384.94	285.77
NOx [g/h]	15.43	160.40	21.53	6.11	305.74	21.38	32.08	37.09	20.25	74.90	55.60
VOC [g/h]	18.38	191.06	25.64	7.28	364.19	25.47	38.21	44.19	24.12	89.21	66.23

**Other Modes**

g_Walk,mi, Effective Walk Time [s]	8.0			8.0			8.0			8.0		
M_corner, Corner Circulation Area [ft <sup>2</sup> /ped]	0.00			0.00			0.00			0.00		
M_CW, Crosswalk Circulation Area [ft <sup>2</sup> /ped]	1666.25			1344.85			261.03			1156.41		
d_p, Pedestrian Delay [s]	57.24			57.24			57.24			57.24		
I_p,int, Pedestrian LOS Score for Intersectio	3.143			2.964			2.317			2.332		
Crosswalk LOS	C			C			B			B		
s_b, Saturation Flow Rate of the bicycle lane	2000			2000			2000			2000		
c_b, Capacity of the bicycle lane [bicycles/h]	657			657			614			552		
d_b, Bicycle Delay [s]	29.30			29.30			31.21			34.25		
I_b,int, Bicycle LOS Score for Intersection	2.236			2.765			2.028			2.230		
Bicycle LOS	B			C			B			B		

**Sequence**

Ring 1	1	2	3	4	-	-	-	-	-	-	-	-	-	-	-
Ring 2	5	6	7	8	-	-	-	-	-	-	-	-	-	-	-
Ring 3	-	-	-	-	-	-	-	-	-	-	-	-	-	-	-
Ring 4	-	-	-	-	-	-	-	-	-	-	-	-	-	-	-

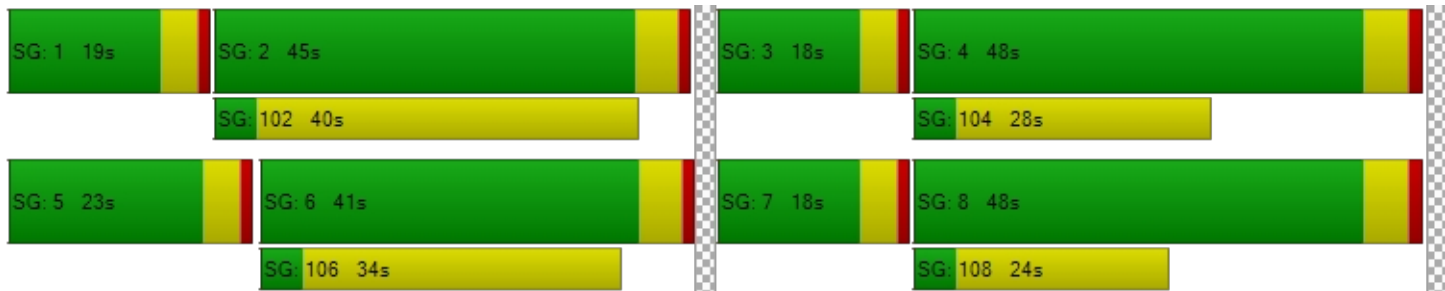

**Intersection Level Of Service Report**  
**Intersection 3: Tassajara Road & Dublin Boulevard**

Control Type:	Signalized	Delay (sec / veh):	39.5
Analysis Method:	HCM 7th Edition	Level Of Service:	D
Analysis Period:	15 minutes	Volume to Capacity (v/c):	0.598

**Intersection Setup**

Name	Tassajara Road			Tassajara Road			Dublin Boulevard			Dublin Boulevard		
Approach	Northbound			Southbound			Eastbound			Westbound		
Lane Configuration	[Diagram]			[Diagram]			[Diagram]			[Diagram]		
Turning Movement	Left	Thru	Right	Left	Thru	Right	Left	Thru	Right	Left	Thru	Right
Lane Width [ft]	12.00	12.00	12.00	12.00	12.00	12.00	12.00	12.00	12.00	12.00	12.00	12.00
No. of Lanes in Entry Pocket	3	0	1	2	0	2	2	0	2	3	0	0
Entry Pocket Length [ft]	380.00	100.00	250.00	295.00	100.00	290.00	265.00	100.00	330.00	395.00	100.00	100.00
No. of Lanes in Exit Pocket	0	0	1	0	0	0	0	0	0	0	0	0
Exit Pocket Length [ft]	0.00	0.00	49.21	0.00	0.00	0.00	0.00	0.00	0.00	0.00	0.00	0.00
Speed [mph]	30.00			40.00			40.00			40.00		
Grade [%]	0.00			0.00			0.00			0.00		
Curb Present	Yes			Yes			Yes			Yes		
Crosswalk	Yes			Yes			Yes			Yes		



**Volumes**

Name	Tassajara Road			Tassajara Road			Dublin Boulevard			Dublin Boulevard		
Base Volume Input [veh/h]	268	631	396	55	1338	130	102	210	148	517	647	74
Base Volume Adjustment Factor	1.0000	1.0000	1.0000	1.0000	1.0000	1.0000	1.0000	1.0000	1.0000	1.0000	1.0000	1.0000
Heavy Vehicles Percentage [%]	3.30	2.90	1.00	0.00	0.70	3.30	2.00	3.70	4.70	1.60	2.00	0.00
Proportion of CAVs [%]	0.00											
Growth Factor	1.0000	1.0000	1.0000	1.0000	1.0000	1.0000	1.0000	1.0000	1.0000	1.0000	1.0000	1.0000
In-Process Volume [veh/h]	0	0	0	0	0	0	0	0	0	0	0	0
Site-Generated Trips [veh/h]	0	0	0	0	0	0	0	0	0	0	0	0
Diverted Trips [veh/h]	0	0	0	0	0	0	0	0	0	0	0	0
Pass-by Trips [veh/h]	0	0	0	0	0	0	0	0	0	0	0	0
Existing Site Adjustment Volume [veh/h]	0	0	0	0	0	0	0	0	0	0	0	0
Other Volume [veh/h]	0	0	0	0	0	0	0	0	0	0	0	0
Right Turn on Red Volume [veh/h]	0	0	0	0	0	0	0	0	0	0	0	0
Total Hourly Volume [veh/h]	268	631	396	55	1338	130	102	210	148	517	647	74
Peak Hour Factor	0.9200	0.9200	0.9200	0.9200	0.9200	0.9200	0.9200	0.9200	0.9200	0.9200	0.9200	0.9200
Other Adjustment Factor	1.0000	1.0000	1.0000	1.0000	1.0000	1.0000	1.0000	1.0000	1.0000	1.0000	1.0000	1.0000
Total 15-Minute Volume [veh/h]	73	171	108	15	364	35	28	57	40	140	176	20
Total Analysis Volume [veh/h]	291	686	430	60	1454	141	111	228	161	562	703	80
Presence of On-Street Parking	No		No	No		No	No		No	No		No
On-Street Parking Maneuver Rate [/h]	0	0	0	0	0	0	0	0	0	0	0	0
Local Bus Stopping Rate [/h]	0	0	0	0	0	0	0	0	0	0	0	0
v_do, Outbound Pedestrian Volume crossing	1			2			2			1		
v_di, Inbound Pedestrian Volume crossing m	1			2			2			1		
v_co, Outbound Pedestrian Volume crossing	0			4			0			3		
v_ci, Inbound Pedestrian Volume crossing mi	0			3			0			4		
v_ab, Corner Pedestrian Volume [ped/h]	0			0			0			0		
Bicycle Volume [bicycles/h]	1			0			0			0		



**Intersection Settings**

Located in CBD	No
Signal Coordination Group	-
Cycle Length [s]	90
Active Pattern	Free Running (No Pattern)
Coordination Type	<i>Free Running</i>
Actuation Type	<i>Fully actuated</i>
Offset [s]	0.0
Offset Reference	Lead Green - Beginning of First Green
Permissive Mode	SingleBand
Lost time [s]	12.00

**Phasing & Timing (Basic)**

Control Type	Protecte	Permiss	Permiss	Protecte	Permiss	Permiss	Protecte	Permiss	Overlap	Protecte	Permiss	Permiss
Signal Group	3	8	0	7	4	0	5	2	2	1	6	0
Auxiliary Signal Groups									2,3			
Maximum Green [s]	20	35	0	20	35	0	20	35	35	20	35	0
Amber [s]	3.5	4.5	0.0	3.5	4.5	0.0	3.5	4.5	4.5	3.5	4.5	0.0
All red [s]	1.5	1.5	0.0	1.5	1.5	0.0	1.5	1.5	1.5	1.5	1.5	0.0
Walk [s]	0	4	0	0	4	0	0	0	0	0	4	0
Pedestrian Clearance [s]	0	29	0	0	42	0	0	0	0	0	42	0
Delayed Vehicle Green [s]	0.0	0.0	0.0	0.0	0.0	0.0	0.0	0.0	0.0	0.0	0.0	0.0
Rest In Walk		No			No			No			No	
I1, Start-Up Lost Time [s]	2.0	2.0	0.0	2.0	2.0	0.0	2.0	2.0	2.0	2.0	2.0	0.0
I2, Clearance Lost Time [s]	2.0	2.0	0.0	2.0	2.0	0.0	2.0	2.0	2.0	2.0	2.0	0.0
Detector Location [ft]	0.0	0.0	0.0	0.0	0.0	0.0	0.0	0.0	0.0	0.0	0.0	0.0
Detector Length [ft]	20.0	20.0	0.0	20.0	20.0	0.0	20.0	20.0	20.0	20.0	20.0	0.0
I, Upstream Filtering Factor	1.00	1.00	1.00	1.00	1.00	1.00	1.00	1.00	1.00	1.00	1.00	1.00

**Phasing & Timing: Free Running (No Pattern)**

Split [s]	0	0	0	0	0	0	0	0	0	0	0	0
Lead / Lag	Lead	-	-	Lead	-	-	Lead	-	-	Lead	-	-
Minimum Green [s]	16	15	0	15	15	0	16	16	16	16	15	0
Vehicle Extension [s]	2.0	4.0	0.0	2.0	4.0	0.0	2.0	3.0	3.0	2.0	3.0	0.0
Minimum Recall	No	Yes		No	Yes		No	No	No	No	No	
Maximum Recall	No	No		No	No		No	No	No	No	No	
Pedestrian Recall	No	No		No	No		No	No	No	No	No	

**Exclusive Pedestrian Phase**

Pedestrian Signal Group	0
Pedestrian Walk [s]	0
Pedestrian Clearance [s]	0



**Lane Group Calculations**

Lane Group	L	C	R	L	C	R	L	C	R	L	C	C
C, Cycle Length [s]	116	116	116	116	116	116	116	116	116	116	116	116
L, Total Lost Time per Cycle [s]	4.00	4.00	4.00	4.00	4.00	4.00	4.00	4.00	4.00	4.00	4.00	4.00
l1_p, Permitted Start-Up Lost Time [s]	0.00	0.00	0.00	0.00	0.00	0.00	0.00	0.00	0.00	0.00	0.00	0.00
l2, Clearance Lost Time [s]	2.00	2.00	2.00	2.00	2.00	2.00	2.00	2.00	0.00	2.00	2.00	2.00
g_i, Effective Green Time [s]	17	38	38	14	35	35	17	31	52	17	31	31
g / C, Green / Cycle	0.15	0.33	0.33	0.12	0.30	0.30	0.14	0.26	0.45	0.15	0.27	0.27
(v / s)_i Volume / Saturation Flow Rate	0.06	0.19	0.27	0.02	0.21	0.05	0.03	0.06	0.06	0.11	0.21	0.21
s, saturation flow rate [veh/h]	5134	3535	1579	3514	6863	2773	3459	3512	2752	5205	1870	1801
c, Capacity [veh/h]	754	1166	521	421	2079	840	495	931	1205	765	503	484
d1, Uniform Delay [s]	44.69	32.26	35.54	45.64	35.70	29.64	43.93	33.46	19.44	47.25	39.32	39.39
k, delay calibration	0.04	0.15	0.40	0.04	0.15	0.15	0.04	0.11	0.11	0.04	0.24	0.24
l, Upstream Filtering Factor	1.00	1.00	1.00	1.00	1.00	1.00	1.00	1.00	1.00	1.00	1.00	1.00
d2, Incremental Delay [s]	0.12	0.68	11.34	0.06	0.62	0.13	0.08	0.14	0.05	0.52	6.04	6.55
d3, Initial Queue Delay [s]	0.00	0.00	0.00	0.00	0.00	0.00	0.00	0.00	0.00	0.00	0.00	0.00
Rp, platoon ratio	1.00	1.00	1.00	1.00	1.00	1.00	1.00	1.00	1.00	1.00	1.00	1.00
PF, progression factor	1.00	1.00	1.00	1.00	1.00	1.00	1.00	1.00	1.00	1.00	1.00	1.00

**Lane Group Results**

X, volume / capacity	0.39	0.59	0.83	0.14	0.70	0.17	0.22	0.24	0.13	0.73	0.79	0.80
d, Delay for Lane Group [s/veh]	44.81	32.94	46.88	45.70	36.32	29.77	44.02	33.59	19.49	47.77	45.36	45.95
Lane Group LOS	D	C	D	D	D	C	D	C	B	D	D	D
Critical Lane Group	No	No	Yes	Yes	No	No	Yes	No	No	No	No	Yes
50th-Percentile Queue Length [veh/ln]	2.53	8.04	12.60	0.76	8.88	1.43	1.39	2.49	1.27	5.09	11.03	10.77
50th-Percentile Queue Length [ft/ln]	63.27	201.07	314.93	19.12	222.02	35.78	34.83	62.29	31.71	127.32	275.67	269.34
95th-Percentile Queue Length [veh/ln]	4.56	12.69	18.42	1.38	13.77	2.58	2.51	4.48	2.28	8.79	16.47	16.16
95th-Percentile Queue Length [ft/ln]	113.88	317.34	460.45	34.42	344.20	64.40	62.70	112.12	57.07	219.84	411.81	403.91





**Movement, Approach, & Intersection Results**

d_M, Delay for Movement [s/veh]	44.81	32.94	46.88	45.70	36.32	29.77	44.02	33.59	19.49	47.77	45.62	45.95
Movement LOS	D	C	D	D	D	C	D	C	B	D	D	D
d_A, Approach Delay [s/veh]	39.65			36.10			31.37			46.54		
Approach LOS	D			D			C			D		
d_I, Intersection Delay [s/veh]	39.50											
Intersection LOS	D											
Intersection V/C	0.598											

**Emissions**

Vehicle Miles Traveled [mph]	59.69	140.72	88.21	17.30	419.31	40.66	97.60	200.48	141.57	676.17	478.29	463.78
Stops [stops/h]	236.24	500.53	391.99	47.60	1105.37	89.06	86.71	155.06	78.93	475.41	343.12	335.24
Fuel consumption [US gal/h]	6.42	13.16	9.90	1.65	36.62	3.19	5.34	10.26	6.49	34.35	24.17	23.51
CO [g/h]	448.45	919.61	691.92	115.01	2560.05	222.68	373.42	717.39	453.30	2401.35	1689.67	1643.35
NOx [g/h]	87.25	178.92	134.62	22.38	498.09	43.32	72.65	139.58	88.20	467.22	328.75	319.74
VOC [g/h]	103.93	213.13	160.36	26.65	593.32	51.61	86.54	166.26	105.06	556.54	391.60	380.86

**Other Modes**

g_Walk,mi, Effective Walk Time [s]	-6.0	8.0	8.0	8.0
M_corner, Corner Circulation Area [ft <sup>2</sup> /ped]	0.00	0.00	0.00	0.00
M_CW, Crosswalk Circulation Area [ft <sup>2</sup> /ped]	0.00	0.00	0.00	0.00
d_p, Pedestrian Delay [s]	64.00	50.12	50.12	50.12
I_p,int, Pedestrian LOS Score for Intersectio	3.340	3.310	3.100	3.075
Crosswalk LOS	C	C	C	C
s_b, Saturation Flow Rate of the bicycle lane	2000	2000	2000	2000
c_b, Capacity of the bicycle lane [bicycles/h]	605	605	605	605
d_b, Bicycle Delay [s]	28.15	28.14	28.14	28.14
I_b,int, Bicycle LOS Score for Intersection	2.720	2.242	1.972	2.669
Bicycle LOS	B	B	A	B

**Sequence**

Ring 1	1	2	3	4	-	-	-	-	-	-	-	-	-	-	-
Ring 2	5	6	7	8	-	-	-	-	-	-	-	-	-	-	-
Ring 3	-	-	-	-	-	-	-	-	-	-	-	-	-	-	-
Ring 4	-	-	-	-	-	-	-	-	-	-	-	-	-	-	-



**Intersection Level Of Service Report**  
**Intersection 4: Tassajara Road & I-580 WB Ramps**

Control Type:	Signalized	Delay (sec / veh):	13.4
Analysis Method:	HCM 7th Edition	Level Of Service:	B
Analysis Period:	15 minutes	Volume to Capacity (v/c):	0.631

**Intersection Setup**

Name	Tassajara Road		Tassajara Road		I-580 WB Ramps	
Approach	Northbound		Southbound		Westbound	
Lane Configuration	↑↑		↑↑↑		←↑↑↑→	
Turning Movement	Thru	Right	Left	Thru	Left	Right
Lane Width [ft]	12.00	12.00	12.00	12.00	12.00	12.00
No. of Lanes in Entry Pocket	0	0	0	0	1	1
Entry Pocket Length [ft]	100.00	100.00	100.00	100.00	100.00	100.00
No. of Lanes in Exit Pocket	0	1	0	0	0	0
Exit Pocket Length [ft]	0.00	49.21	0.00	0.00	0.00	0.00
Speed [mph]	30.00		30.00		30.00	
Grade [%]	0.00		0.00		0.00	
Curb Present	No		No		No	
Crosswalk	Yes		Yes		Yes	



**Volumes**

Name	Tassajara Road		Tassajara Road		I-580 WB Ramps	
Base Volume Input [veh/h]	1345	0	0	936	631	354
Base Volume Adjustment Factor	1.0000	1.0000	1.0000	1.0000	1.0000	1.0000
Heavy Vehicles Percentage [%]	2.30	2.00	2.00	1.80	2.90	4.00
Proportion of CAVs [%]	0.00					
Growth Factor	1.0000	1.0000	1.0000	1.0000	1.0000	1.0000
In-Process Volume [veh/h]	0	0	0	0	0	0
Site-Generated Trips [veh/h]	0	0	0	0	0	0
Diverted Trips [veh/h]	0	0	0	0	0	0
Pass-by Trips [veh/h]	0	0	0	0	0	0
Existing Site Adjustment Volume [veh/h]	0	0	0	0	0	0
Other Volume [veh/h]	0	0	0	0	0	0
Right Turn on Red Volume [veh/h]	0	0	0	0	0	0
Total Hourly Volume [veh/h]	1345	0	0	936	631	354
Peak Hour Factor	0.9800	1.0000	1.0000	0.9800	0.9800	0.9800
Other Adjustment Factor	1.0000	1.0000	1.0000	1.0000	1.0000	1.0000
Total 15-Minute Volume [veh/h]	343	0	0	239	161	90
Total Analysis Volume [veh/h]	1372	0	0	955	644	361
Presence of On-Street Parking	No	No	No	No	No	No
On-Street Parking Maneuver Rate [/h]	0	0	0	0	0	0
Local Bus Stopping Rate [/h]	0	0	0	0	0	0
v_do, Outbound Pedestrian Volume crossing	0		0		0	
v_di, Inbound Pedestrian Volume crossing m	0		0		0	
v_co, Outbound Pedestrian Volume crossing	0		0		0	
v_ci, Inbound Pedestrian Volume crossing mi	0		0		0	
v_ab, Corner Pedestrian Volume [ped/h]	0		0		0	
Bicycle Volume [bicycles/h]	0		0		0	



**Intersection Settings**

Located in CBD	No
Signal Coordination Group	-
Cycle Length [s]	60
Active Pattern	Pattern 1
Coordination Type	Time of Day Pattern Coordinated
Actuation Type	Fully actuated
Offset [s]	20.0
Offset Reference	Beginning of First Yellow
Permissive Mode	SingleBand
Lost time [s]	6.00

**Phasing & Timing (Basic)**

Control Type	Permissive	Permissive	Permissive	Permissive	Split	Split
Signal Group	6	0	0	2	4	0
Auxiliary Signal Groups						
Maximum Green [s]	40	0	0	40	20	0
Amber [s]	4.9	0.0	0.0	4.9	4.4	0.0
All red [s]	1.0	0.0	0.0	1.0	1.0	0.0
Walk [s]	5	0	0	0	0	0
Pedestrian Clearance [s]	16	0	0	0	0	0
Delayed Vehicle Green [s]	0.0	0.0	0.0	0.0	0.0	0.0
Rest In Walk	No			No	No	
I1, Start-Up Lost Time [s]	2.0	0.0	0.0	2.0	2.0	0.0
I2, Clearance Lost Time [s]	3.9	0.0	0.0	3.9	3.4	0.0
Detector Location [ft]	0.0	0.0	0.0	0.0	0.0	0.0
Detector Length [ft]	20.0	0.0	0.0	20.0	20.0	0.0
I, Upstream Filtering Factor	1.00	1.00	1.00	1.00	1.00	1.00

**Phasing & Timing: Pattern 1**

Split [s]	38	0	0	38	22	0
Lead / Lag	-	-	-	-	Lead	-
Minimum Green [s]	7	0	0	7	4	0
Vehicle Extension [s]	3.0	0.0	0.0	3.0	2.0	0.0
Minimum Recall	No			No	No	
Maximum Recall	Yes			Yes	No	
Pedestrian Recall	Yes			No	No	

**Exclusive Pedestrian Phase**

Pedestrian Signal Group	0
Pedestrian Walk [s]	0
Pedestrian Clearance [s]	0



**Lane Group Calculations**

Lane Group	C	C	L	R
C, Cycle Length [s]	66	66	66	66
L, Total Lost Time per Cycle [s]	5.90	5.90	5.40	5.40
l1_p, Permitted Start-Up Lost Time [s]	0.00	0.00	0.00	0.00
l2, Clearance Lost Time [s]	3.90	3.90	3.40	3.40
g_i, Effective Green Time [s]	40	40	15	15
g / C, Green / Cycle	0.61	0.61	0.22	0.22
(v / s)_i Volume / Saturation Flow Rate	0.39	0.19	0.19	0.13
s, saturation flow rate [veh/h]	3552	5102	3434	2768
c, Capacity [veh/h]	2151	3090	767	618
d1, Uniform Delay [s]	8.37	6.32	24.52	22.91
k, delay calibration	0.50	0.50	0.04	0.04
l, Upstream Filtering Factor	1.00	1.00	1.00	1.00
d2, Incremental Delay [s]	1.46	0.26	0.97	0.33
d3, Initial Queue Delay [s]	0.00	0.00	0.00	0.00
Rp, platoon ratio	1.00	1.00	1.00	1.00
PF, progression factor	1.00	1.00	1.00	1.00

**Lane Group Results**

X, volume / capacity	0.64	0.31	0.84	0.58
d, Delay for Lane Group [s/veh]	9.83	6.58	25.50	23.24
Lane Group LOS	A	A	C	C
Critical Lane Group	Yes	No	Yes	No
50th-Percentile Queue Length [veh/ln]	5.28	1.77	4.61	2.39
50th-Percentile Queue Length [ft/ln]	132.05	44.31	115.21	59.68
95th-Percentile Queue Length [veh/ln]	9.05	3.19	8.13	4.30
95th-Percentile Queue Length [ft/ln]	226.27	79.75	203.23	107.43

**Movement, Approach, & Intersection Results**

d_M, Delay for Movement [s/veh]	9.83	0.00	0.00	6.58	25.50	23.24
Movement LOS	A			A	C	C
d_A, Approach Delay [s/veh]	9.83		6.58		24.68	
Approach LOS	A		A		C	
d_I, Intersection Delay [s/veh]	13.38					
Intersection LOS	B					
Intersection V/C	0.631					

**Emissions**

Vehicle Miles Traveled [mph]	231.03	195.90	52.08	29.20
Stops [stops/h]	576.30	290.05	502.83	260.48
Fuel consumption [US gal/h]	15.44	10.95	8.26	4.35
CO [g/h]	1079.24	765.13	577.63	303.93
NOx [g/h]	209.98	148.87	112.39	59.13
VOC [g/h]	250.12	177.33	133.87	70.44

**Other Modes**

g_Walk,mi, Effective Walk Time [s]	16.6	16.6	9.0
M_corner, Corner Circulation Area [ft <sup>2</sup> /ped]	0.00	0.00	0.00
M_CW, Crosswalk Circulation Area [ft <sup>2</sup> /ped]	0.00	0.00	0.00
d_p, Pedestrian Delay [s]	18.48	18.48	24.61
I_p,int, Pedestrian LOS Score for Intersectio	2.853	2.798	2.482
Crosswalk LOS	C	C	B
s_b, Saturation Flow Rate of the bicycle lane	2000	2000	2000
c_b, Capacity of the bicycle lane [bicycles/h]	973	973	503
d_b, Bicycle Delay [s]	8.70	8.70	18.48
I_b,int, Bicycle LOS Score for Intersection	2.692	2.085	1.560
Bicycle LOS	B	B	A

**Sequence**

Ring 1	-	2	-	4	-	-	-	-	-	-	-	-	-	-	-	-
Ring 2	-	6	-	-	-	-	-	-	-	-	-	-	-	-	-	-
Ring 3	-	-	-	-	-	-	-	-	-	-	-	-	-	-	-	-
Ring 4	-	-	-	-	-	-	-	-	-	-	-	-	-	-	-	-



**Intersection Level Of Service Report**  
**Intersection 5: Santa Rita Rd & I-580 EB Ramps/Pimlico Dr**

Control Type:	Signalized	Delay (sec / veh):	32.5
Analysis Method:	HCM 7th Edition	Level Of Service:	C
Analysis Period:	15 minutes	Volume to Capacity (v/c):	0.753

**Intersection Setup**

Name	Santa Rita Road			Tassajara Road			I-580 EB Ramps			Pimlico Drive		
Approach	Northbound			Southbound			Eastbound			Westbound		
Lane Configuration	↑			↵			↵↑			↵↵↵↑		
Turning Movement	Left	Thru	Right	Left	Thru	Right	Left	Thru	Right	Left	Thru	Right
Lane Width [ft]	12.00	12.00	12.00	12.00	12.00	12.00	12.00	12.00	12.00	12.00	12.00	12.00
No. of Lanes in Entry Pocket	0	0	1	1	0	0	1	0	0	2	0	1
Entry Pocket Length [ft]	100.00	100.00	250.00	425.00	100.00	100.00	625.00	100.00	100.00	200.00	100.00	250.00
No. of Lanes in Exit Pocket	0	0	0	0	0	2	0	0	0	0	0	0
Exit Pocket Length [ft]	0.00	0.00	0.00	0.00	0.00	49.21	0.00	0.00	0.00	0.00	0.00	0.00
Speed [mph]	30.00			30.00			30.00			30.00		
Grade [%]	0.00			0.00			0.00			0.00		
Curb Present	No			No			No			No		
Crosswalk	Yes			No			Yes			Yes		



**Volumes**

Name	Santa Rita Road			Tassajara Road			I-580 EB Ramps			Pimlico Drive		
Base Volume Input [veh/h]	0	984	84	164	1235	0	765	128	0	142	0	291
Base Volume Adjustment Factor	1.0000	1.0000	1.0000	1.0000	1.0000	1.0000	1.0000	1.0000	1.0000	1.0000	1.0000	1.0000
Heavy Vehicles Percentage [%]	2.00	3.30	2.40	1.80	2.30	2.00	2.10	2.40	2.00	0.70	2.00	2.40
Proportion of CAVs [%]	0.00											
Growth Factor	1.0000	1.0000	1.0000	1.0000	1.0000	1.0000	1.0000	1.0000	1.0000	1.0000	1.0000	1.0000
In-Process Volume [veh/h]	0	0	0	0	0	0	0	0	0	0	0	0
Site-Generated Trips [veh/h]	0	0	0	0	0	0	0	0	0	0	0	0
Diverted Trips [veh/h]	0	0	0	0	0	0	0	0	0	0	0	0
Pass-by Trips [veh/h]	0	0	0	0	0	0	0	0	0	0	0	0
Existing Site Adjustment Volume [veh/h]	0	0	0	0	0	0	0	0	0	0	0	0
Other Volume [veh/h]	0	0	0	0	0	0	0	0	0	0	0	0
Right Turn on Red Volume [veh/h]	0	0	0	0	0	0	0	0	0	0	0	0
Total Hourly Volume [veh/h]	0	984	84	164	1235	0	765	128	0	142	0	291
Peak Hour Factor	1.0000	0.9600	0.9600	0.9600	0.9600	1.0000	0.9600	0.9600	1.0000	0.9600	1.0000	0.9600
Other Adjustment Factor	1.0000	1.0000	1.0000	1.0000	1.0000	1.0000	1.0000	1.0000	1.0000	1.0000	1.0000	1.0000
Total 15-Minute Volume [veh/h]	0	256	22	43	322	0	199	33	0	37	0	76
Total Analysis Volume [veh/h]	0	1025	88	171	1286	0	797	133	0	148	0	303
Presence of On-Street Parking	No		No	No		No	No		No	No		No
On-Street Parking Maneuver Rate [/h]	0	0	0	0	0	0	0	0	0	0	0	0
Local Bus Stopping Rate [/h]	0	0	0	0	0	0	0	0	0	0	0	0
v_do, Outbound Pedestrian Volume crossing	5			0			5			0		
v_di, Inbound Pedestrian Volume crossing m	5			0			5			0		
v_co, Outbound Pedestrian Volume crossing	0			2			2			1		
v_ci, Inbound Pedestrian Volume crossing mi	1			2			2			0		
v_ab, Corner Pedestrian Volume [ped/h]	0			0			0			0		
Bicycle Volume [bicycles/h]	0			0			0			0		





**Intersection Settings**

Located in CBD	No
Signal Coordination Group	-
Cycle Length [s]	120
Active Pattern	Pattern 1
Coordination Type	Time of Day Pattern Coordinated
Actuation Type	Fully actuated
Offset [s]	20.0
Offset Reference	Lead Green - Beginning of First Green
Permissive Mode	SingleBand
Lost time [s]	12.00

**Phasing & Timing (Basic)**

Control Type	Permiss	Permiss	Permiss	Protecte	Permiss	Permiss	Protecte	Permiss	Permiss	Permiss	Permiss	Overlap
Signal Group	0	6	0	5	2	0	3	8	0	7	0	4
Auxiliary Signal Groups												4,5
Maximum Green [s]	0	30	0	20	30	0	35	20	0	20	0	20
Amber [s]	0.0	4.4	0.0	3.0	4.4	0.0	4.4	4.4	0.0	3.5	0.0	3.5
All red [s]	0.0	1.0	0.0	1.0	1.0	0.0	1.0	1.0	0.0	1.0	0.0	1.0
Walk [s]	0	5	0	0	5	0	0	5	0	0	0	0
Pedestrian Clearance [s]	0	25	0	0	8	0	0	25	0	0	0	0
Delayed Vehicle Green [s]	0.0	0.0	0.0	0.0	0.0	0.0	0.0	0.0	0.0	0.0	0.0	0.0
Rest In Walk		No			No			No		No		
I1, Start-Up Lost Time [s]	0.0	2.0	0.0	2.0	2.0	0.0	2.0	2.0	0.0	2.0	0.0	2.0
I2, Clearance Lost Time [s]	0.0	3.4	0.0	2.0	3.4	0.0	3.4	3.4	0.0	2.5	0.0	2.5
Detector Location [ft]	0.0	0.0	0.0	0.0	0.0	0.0	0.0	0.0	0.0	0.0	0.0	0.0
Detector Length [ft]	0.0	20.0	0.0	20.0	20.0	0.0	20.0	20.0	0.0	20.0	0.0	0.0
I, Upstream Filtering Factor	1.00	1.00	1.00	1.00	1.00	1.00	1.00	1.00	1.00	1.00	1.00	1.00

**Phasing & Timing: Pattern 1**

Split [s]	0	41	0	25	66	0	40	36	0	18	0	14
Lead / Lag	-	-	-	Lead	-	-	Lead	-	-	Lead	-	-
Minimum Green [s]	0	7	0	5	7	0	5	5	0	5	0	5
Vehicle Extension [s]	0.0	3.0	0.0	3.0	3.0	0.0	3.0	2.0	0.0	3.0	0.0	2.0
Minimum Recall		No		No	No		No	No		No		No
Maximum Recall		Yes		No	Yes		No	No		No		No
Pedestrian Recall		No		No	Yes		No	No		No		No

**Exclusive Pedestrian Phase**

Pedestrian Signal Group	0
Pedestrian Walk [s]	0
Pedestrian Clearance [s]	0



**Lane Group Calculations**

Lane Group	C	C	L	C	L	C	L	R
C, Cycle Length [s]	120	120	120	120	120	120	120	120
L, Total Lost Time per Cycle [s]	5.40	5.40	4.00	5.40	5.40	5.40	4.50	4.00
l1_p, Permitted Start-Up Lost Time [s]	0.00	0.00	0.00	0.00	0.00	0.00	0.00	0.00
l2, Clearance Lost Time [s]	3.40	3.40	2.00	3.40	3.40	3.40	2.50	0.00
g_i, Effective Green Time [s]	51	51	14	68	31	29	7	24
g / C, Green / Cycle	0.42	0.42	0.12	0.57	0.25	0.24	0.06	0.20
(v / s)_i Volume / Saturation Flow Rate	0.21	0.16	0.10	0.36	0.23	0.07	0.04	0.11
s, saturation flow rate [veh/h]	4053	1752	1784	3552	3456	1864	3495	2804
c, Capacity [veh/h]	1710	739	206	2027	878	449	213	562
d1, Uniform Delay [s]	25.23	23.82	51.91	17.33	43.36	37.19	55.23	42.96
k, delay calibration	0.50	0.50	0.13	0.50	0.11	0.04	0.11	0.04
l, Upstream Filtering Factor	1.00	1.00	1.00	1.00	1.00	1.00	1.00	1.00
d2, Incremental Delay [s]	1.00	1.46	9.64	1.53	3.97	0.14	4.08	0.30
d3, Initial Queue Delay [s]	0.00	0.00	0.00	0.00	0.00	0.00	0.00	0.00
Rp, platoon ratio	1.00	1.00	1.00	1.00	1.00	1.00	1.00	1.00
PF, progression factor	1.00	1.00	1.00	1.00	1.00	1.00	1.00	1.00

**Lane Group Results**

X, volume / capacity	0.49	0.38	0.83	0.63	0.91	0.30	0.70	0.54
d, Delay for Lane Group [s/veh]	26.23	25.28	61.55	18.86	47.33	37.33	59.31	43.26
Lane Group LOS	C	C	E	B	D	D	E	D
Critical Lane Group	No	No	No	Yes	Yes	No	No	Yes
50th-Percentile Queue Length [veh/ln]	5.90	5.72	5.58	11.95	11.86	3.22	2.32	4.06
50th-Percentile Queue Length [ft/ln]	147.51	143.01	139.51	298.78	296.52	80.61	57.90	101.45
95th-Percentile Queue Length [veh/ln]	9.88	9.64	9.45	17.62	17.51	5.80	4.17	7.30
95th-Percentile Queue Length [ft/ln]	247.10	241.07	236.36	440.52	437.72	145.10	104.22	182.61

**Movement, Approach, & Intersection Results**

d_M, Delay for Movement [s/veh]	0.00	26.06	25.28	61.55	18.86	0.00	47.33	37.33	0.00	59.31	0.00	43.26
Movement LOS		C	C	E	B		D	D		E		D
d_A, Approach Delay [s/veh]	26.00			23.87			45.90			48.53		
Approach LOS	C			C			D			D		
d_I, Intersection Delay [s/veh]	32.47											
Intersection LOS	C											
Intersection V/C	0.753											

**Emissions**

Vehicle Miles Traveled [mph]	82.33	27.44	28.79	216.55	110.59	18.45	12.63	25.86
Stops [stops/h]	531.21	171.67	167.47	717.32	711.88	96.77	139.01	243.56
Fuel consumption [US gal/h]	10.78	3.51	4.25	17.81	16.16	2.30	3.07	5.08
CO [g/h]	753.55	245.33	297.22	1245.18	1129.66	161.09	214.87	354.93
NOx [g/h]	146.61	47.73	57.83	242.27	219.79	31.34	41.81	69.06
VOC [g/h]	174.64	56.86	68.88	288.58	261.81	37.33	49.80	82.26

**Other Modes**

g_Walk,mi, Effective Walk Time [s]	9.0	0.0	9.0	9.0
M_corner, Corner Circulation Area [ft <sup>2</sup> /ped]	0.00	0.00	0.00	0.00
M_CW, Crosswalk Circulation Area [ft <sup>2</sup> /ped]	653.31	0.00	0.00	0.00
d_p, Pedestrian Delay [s]	51.32	0.00	51.32	51.32
I_p,int, Pedestrian LOS Score for Intersectio	2.882	0.000	2.373	2.479
Crosswalk LOS	C	F	B	B
s_b, Saturation Flow Rate of the bicycle lane	2000	2000	2000	2000
c_b, Capacity of the bicycle lane [bicycles/h]	594	1010	510	225
d_b, Bicycle Delay [s]	29.66	14.69	33.28	47.24
I_b,int, Bicycle LOS Score for Intersection	2.019	2.762	3.094	1.560
Bicycle LOS	B	C	C	A

**Sequence**

Ring 1	-	2	3	4	-	-	-	-	-	-	-	-	-	-	-
Ring 2	5	6	7	8	-	-	-	-	-	-	-	-	-	-	-
Ring 3	-	-	-	-	-	-	-	-	-	-	-	-	-	-	-
Ring 4	-	-	-	-	-	-	-	-	-	-	-	-	-	-	-

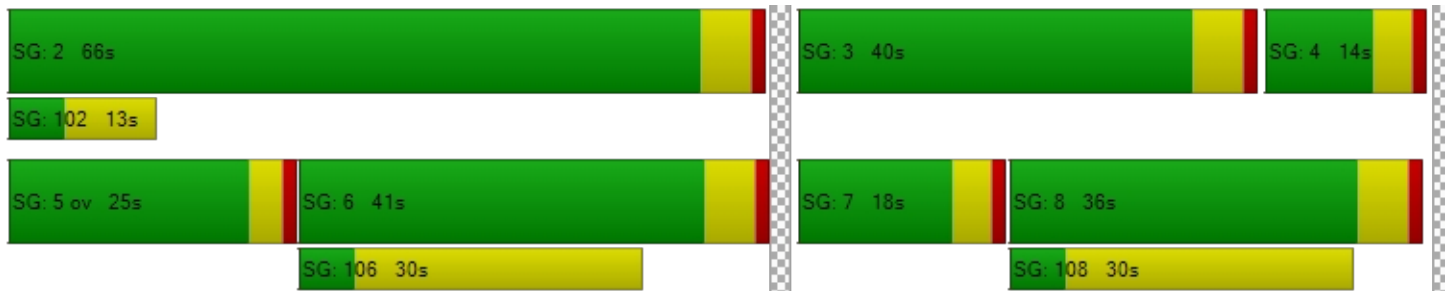

**Intersection Level Of Service Report**  
**Intersection 6: Tassajara Road & Fallon Road**

Control Type:	Signalized	Delay (sec / veh):	22.8
Analysis Method:	HCM 7th Edition	Level Of Service:	C
Analysis Period:	15 minutes	Volume to Capacity (v/c):	0.666

**Intersection Setup**

Name	Fallon Road			Fallon Road			Tassajara Road			Syrah Drive		
Approach	Northbound			Southbound			Eastbound			Westbound		
Lane Configuration												
Turning Movement	Left	Thru	Right	Left	Thru	Right	Left	Thru	Right	Left	Thru	Right
Lane Width [ft]	12.00	12.00	12.00	12.00	12.00	12.00	12.00	12.00	12.00	12.00	12.00	12.00
No. of Lanes in Entry Pocket	1	0	1	1	0	2	1	0	1	1	0	1
Entry Pocket Length [ft]	175.00	100.00	175.00	175.00	100.00	225.00	475.00	100.00	175.00	100.00	100.00	100.00
No. of Lanes in Exit Pocket	0	0	0	0	0	0	0	0	0	0	0	0
Exit Pocket Length [ft]	0.00	0.00	0.00	0.00	0.00	0.00	0.00	0.00	0.00	0.00	0.00	0.00
Speed [mph]	30.00			30.00			30.00			30.00		
Grade [%]	0.00			0.00			0.00			0.00		
Curb Present	No			No			No			No		
Crosswalk	Yes			Yes			Yes			Yes		



**Volumes**

Name	Fallon Road			Fallon Road			Tassajara Road			Syrah Drive		
Base Volume Input [veh/h]	202	293	12	2	342	513	227	12	206	18	34	10
Base Volume Adjustment Factor	1.0000	1.0000	1.0000	1.0000	1.0000	1.0000	1.0000	1.0000	1.0000	1.0000	1.0000	1.0000
Heavy Vehicles Percentage [%]	1.00	1.70	0.00	0.00	0.60	0.20	1.40	0.00	0.50	0.00	0.00	0.00
Proportion of CAVs [%]	0.00											
Growth Factor	1.0000	1.0000	1.0000	1.0000	1.0000	1.0000	1.0000	1.0000	1.0000	1.0000	1.0000	1.0000
In-Process Volume [veh/h]	0	0	0	0	0	0	0	0	0	0	0	0
Site-Generated Trips [veh/h]	0	0	0	0	0	0	0	0	0	0	0	0
Diverted Trips [veh/h]	0	0	0	0	0	0	0	0	0	0	0	0
Pass-by Trips [veh/h]	0	0	0	0	0	0	0	0	0	0	0	0
Existing Site Adjustment Volume [veh/h]	0	0	0	0	0	0	0	0	0	0	0	0
Other Volume [veh/h]	0	0	0	0	0	0	0	0	0	0	0	0
Right Turn on Red Volume [veh/h]	0	0	0	0	0	0	0	0	0	0	0	0
Total Hourly Volume [veh/h]	202	293	12	2	342	513	227	12	206	18	34	10
Peak Hour Factor	0.7800	0.7800	0.7800	0.7800	0.7800	0.7800	0.7800	0.7800	0.7800	0.7800	0.7800	0.7800
Other Adjustment Factor	1.0000	1.0000	1.0000	1.0000	1.0000	1.0000	1.0000	1.0000	1.0000	1.0000	1.0000	1.0000
Total 15-Minute Volume [veh/h]	65	94	4	1	110	164	73	4	66	6	11	3
Total Analysis Volume [veh/h]	259	376	15	3	438	658	291	15	264	23	44	13
Presence of On-Street Parking	No		No	No		No	No		No	No		No
On-Street Parking Maneuver Rate [/h]	0	0	0	0	0	0	0	0	0	0	0	0
Local Bus Stopping Rate [/h]	0	0	0	0	0	0	0	0	0	0	0	0
v_do, Outbound Pedestrian Volume crossing	1			0			0			0		
v_di, Inbound Pedestrian Volume crossing m	0			0			1			0		
v_co, Outbound Pedestrian Volume crossing	0			0			1			0		
v_ci, Inbound Pedestrian Volume crossing mi	0			1			0			0		
v_ab, Corner Pedestrian Volume [ped/h]	0			0			0			0		
Bicycle Volume [bicycles/h]	0			0			0			0		



**Intersection Settings**

Located in CBD	No
Signal Coordination Group	-
Cycle Length [s]	90
Active Pattern	Free Running (No Pattern)
Coordination Type	<i>Free Running</i>
Actuation Type	<i>Fully actuated</i>
Offset [s]	0.0
Offset Reference	Lead Green - Beginning of First Green
Permissive Mode	SingleBand
Lost time [s]	12.00

**Phasing & Timing (Basic)**

Control Type	Protecte	Permiss	Permiss	Protecte	Permiss	Permiss	Protecte	Permiss	Permiss	Protecte	Permiss	Permiss
Signal Group	3	8	0	7	4	0	5	2	0	1	6	0
Auxiliary Signal Groups												
Maximum Green [s]	25	50	0	25	50	0	35	30	0	20	30	0
Amber [s]	3.5	4.8	0.0	3.5	4.8	0.0	3.5	5.0	0.0	3.0	3.6	0.0
All red [s]	1.0	1.0	0.0	1.0	1.0	0.0	1.0	1.0	0.0	1.0	1.0	0.0
Walk [s]	0	4	0	0	0	0	0	4	0	0	3	0
Pedestrian Clearance [s]	0	25	0	0	0	0	0	28	0	0	36	0
Delayed Vehicle Green [s]	0.0	0.0	0.0	0.0	0.0	0.0	0.0	0.0	0.0	0.0	0.0	0.0
Rest In Walk		No			No			No			No	
I1, Start-Up Lost Time [s]	2.0	2.0	0.0	2.0	2.0	0.0	2.0	2.0	0.0	2.0	2.0	0.0
I2, Clearance Lost Time [s]	2.0	2.0	0.0	2.0	2.0	0.0	2.0	2.0	0.0	2.0	2.0	0.0
Detector Location [ft]	0.0	0.0	0.0	0.0	0.0	0.0	0.0	0.0	0.0	0.0	0.0	0.0
Detector Length [ft]	0.0	0.0	0.0	0.0	0.0	0.0	0.0	0.0	0.0	0.0	0.0	0.0
I, Upstream Filtering Factor	1.00	1.00	1.00	1.00	1.00	1.00	1.00	1.00	1.00	1.00	1.00	1.00

**Phasing & Timing: Free Running (No Pattern)**

Split [s]	0	0	0	0	0	0	0	0	0	0	0	0
Lead / Lag	Lead	-	-	Lead	-	-	Lead	-	-	Lead	-	-
Minimum Green [s]	9	10	0	9	10	0	11	8	0	12	9	0
Vehicle Extension [s]	3.0	3.0	0.0	3.0	3.0	0.0	3.0	3.0	0.0	3.0	3.0	0.0
Minimum Recall	No	No		No	No		Yes	No		No	No	
Maximum Recall	No	No		No	No		No	No		No	No	
Pedestrian Recall	No	No		No	No		No	No		No	No	

**Exclusive Pedestrian Phase**

Pedestrian Signal Group	0
Pedestrian Walk [s]	0
Pedestrian Clearance [s]	0



**Lane Group Calculations**

Lane Group	L	C	R	L	C	R	L	C	R	L	C	R
C, Cycle Length [s]	70	70	70	70	70	70	70	70	70	70	70	70
L, Total Lost Time per Cycle [s]	4.00	4.00	4.00	4.00	4.00	4.00	4.00	4.00	4.00	4.00	4.00	4.00
l1_p, Permitted Start-Up Lost Time [s]	0.00	0.00	0.00	0.00	0.00	0.00	0.00	0.00	0.00	0.00	0.00	0.00
l2, Clearance Lost Time [s]	2.00	2.00	2.00	2.00	2.00	2.00	2.00	2.00	2.00	2.00	2.00	2.00
g_i, Effective Green Time [s]	13	33	33	1	22	22	11	16	16	4	8	8
g / C, Green / Cycle	0.18	0.47	0.47	0.01	0.31	0.31	0.16	0.22	0.22	0.06	0.12	0.12
(v / s)_i Volume / Saturation Flow Rate	0.14	0.11	0.01	0.00	0.12	0.23	0.08	0.01	0.16	0.01	0.02	0.01
s, saturation flow rate [veh/h]	1795	3569	1615	1810	3600	2854	3475	1900	1606	1810	1900	1615
c, Capacity [veh/h]	324	1692	766	26	1109	879	566	422	357	112	231	196
d1, Uniform Delay [s]	27.62	10.88	9.83	34.24	19.19	21.90	26.92	21.47	25.48	31.36	27.82	27.39
k, delay calibration	0.11	0.11	0.11	0.11	0.11	0.11	0.11	0.11	0.11	0.11	0.11	0.11
l, Upstream Filtering Factor	1.00	1.00	1.00	1.00	1.00	1.00	1.00	1.00	1.00	1.00	1.00	1.00
d2, Incremental Delay [s]	4.55	0.07	0.01	1.92	0.23	1.30	0.72	0.03	3.03	0.89	0.40	0.14
d3, Initial Queue Delay [s]	0.00	0.00	0.00	0.00	0.00	0.00	0.00	0.00	0.00	0.00	0.00	0.00
Rp, platoon ratio	1.00	1.00	1.00	1.00	1.00	1.00	1.00	1.00	1.00	1.00	1.00	1.00
PF, progression factor	1.00	1.00	1.00	1.00	1.00	1.00	1.00	1.00	1.00	1.00	1.00	1.00

**Lane Group Results**

X, volume / capacity	0.80	0.22	0.02	0.11	0.39	0.75	0.51	0.04	0.74	0.20	0.19	0.07
d, Delay for Lane Group [s/veh]	32.17	10.95	9.84	36.16	19.42	23.21	27.64	21.50	28.51	32.25	28.22	27.54
Lane Group LOS	C	B	A	D	B	C	C	C	C	C	C	C
Critical Lane Group	Yes	No	No	No	No	Yes	No	No	Yes	Yes	No	No
50th-Percentile Queue Length [veh/ln]	4.38	1.57	0.11	0.06	2.68	4.70	2.19	0.19	4.18	0.39	0.67	0.19
50th-Percentile Queue Length [ft/ln]	109.44	39.18	2.85	1.58	67.10	117.53	54.81	4.75	104.61	9.67	16.71	4.87
95th-Percentile Queue Length [veh/ln]	7.81	2.82	0.21	0.11	4.83	8.26	3.95	0.34	7.53	0.70	1.20	0.35
95th-Percentile Queue Length [ft/ln]	195.23	70.52	5.13	2.84	120.77	206.42	98.66	8.55	188.30	17.41	30.08	8.76



**Movement, Approach, & Intersection Results**

d_M, Delay for Movement [s/veh]	32.17	10.95	9.84	36.16	19.42	23.21	27.64	21.50	28.51	32.25	28.22	27.54
Movement LOS	C	B	A	D	B	C	C	C	C	C	C	C
d_A, Approach Delay [s/veh]	19.38			21.73			27.88			29.26		
Approach LOS	B			C			C			C		
d_I, Intersection Delay [s/veh]	22.81											
Intersection LOS	C											
Intersection V/C	0.666											

**Emissions**

Vehicle Miles Traveled [mph]	24.68	35.83	1.43	0.33	47.54	71.42	37.53	1.93	34.05	0.83	1.58	0.47
Stops [stops/h]	224.32	160.61	5.84	3.23	275.05	481.78	224.67	9.73	214.42	19.83	34.25	9.98
Fuel consumption [US gal/h]	3.95	3.20	0.12	0.05	5.21	8.71	4.42	0.20	4.12	0.29	0.51	0.15
CO [g/h]	276.17	223.69	8.47	3.73	364.01	608.79	309.18	13.91	287.83	20.58	35.43	10.29
NOx [g/h]	53.73	43.52	1.65	0.73	70.82	118.45	60.16	2.71	56.00	4.00	6.89	2.00
VOC [g/h]	64.00	51.84	1.96	0.86	84.36	141.09	71.66	3.22	66.71	4.77	8.21	2.38

**Other Modes**

g_Walk,mi, Effective Walk Time [s]	8.0			7.0			-5.8			8.0		
M_corner, Corner Circulation Area [ft <sup>2</sup> /ped]	0.00			0.00			0.00			0.00		
M_CW, Crosswalk Circulation Area [ft <sup>2</sup> /ped]	0.00			0.00			0.00			0.00		
d_p, Pedestrian Delay [s]	27.58			28.48			41.17			27.58		
I_p,int, Pedestrian LOS Score for Intersectio	2.667			2.833			2.708			2.149		
Crosswalk LOS	B			C			B			B		
s_b, Saturation Flow Rate of the bicycle lane	2000			2000			2000			2000		
c_b, Capacity of the bicycle lane [bicycles/h]	1423			1423			854			854		
d_b, Bicycle Delay [s]	2.92			2.92			11.53			11.53		
I_b,int, Bicycle LOS Score for Intersection	2.096			2.466			2.500			1.692		
Bicycle LOS	B			B			B			A		

**Sequence**

Ring 1	1	2	3	4	-	-	-	-	-	-	-	-	-	-	-
Ring 2	5	6	7	8	-	-	-	-	-	-	-	-	-	-	-
Ring 3	-	-	-	-	-	-	-	-	-	-	-	-	-	-	-
Ring 4	-	-	-	-	-	-	-	-	-	-	-	-	-	-	-





**Intersection Level Of Service Report**  
**Intersection 7: Fallon Road & Positano Parkway**

Control Type:	Signalized	Delay (sec / veh):	31.3
Analysis Method:	HCM 7th Edition	Level Of Service:	C
Analysis Period:	15 minutes	Volume to Capacity (v/c):	0.857

**Intersection Setup**

Name	Fallon Road		Fallon Road		Positano Parkway	
Approach	Northbound		Southbound		Westbound	
Lane Configuration	↑↑↑↔		↔↑↑↑		↔↔↔	
Turning Movement	Thru	Right	Left	Thru	Left	Right
Lane Width [ft]	12.00	12.00	12.00	12.00	12.00	12.00
No. of Lanes in Entry Pocket	0	1	1	0	1	1
Entry Pocket Length [ft]	100.00	225.00	325.00	100.00	375.00	425.00
No. of Lanes in Exit Pocket	0	0	0	0	0	0
Exit Pocket Length [ft]	0.00	0.00	0.00	0.00	0.00	0.00
Speed [mph]	30.00		30.00		30.00	
Grade [%]	0.00		0.00		0.00	
Curb Present	No		No		No	
Crosswalk	Yes		Yes		Yes	



**Volumes**

Name	Fallon Road		Fallon Road		Positano Parkway	
Base Volume Input [veh/h]	365	185	350	644	562	502
Base Volume Adjustment Factor	1.0000	1.0000	1.0000	1.0000	1.0000	1.0000
Heavy Vehicles Percentage [%]	2.90	0.50	0.30	0.60	0.00	0.70
Proportion of CAVs [%]	0.00					
Growth Factor	1.0000	1.0000	1.0000	1.0000	1.0000	1.0000
In-Process Volume [veh/h]	0	0	0	0	0	0
Site-Generated Trips [veh/h]	0	0	0	0	0	0
Diverted Trips [veh/h]	0	0	0	0	0	0
Pass-by Trips [veh/h]	0	0	0	0	0	0
Existing Site Adjustment Volume [veh/h]	0	0	0	0	0	0
Other Volume [veh/h]	0	0	0	0	0	0
Right Turn on Red Volume [veh/h]	0	0	0	0	0	0
Total Hourly Volume [veh/h]	365	185	350	644	562	502
Peak Hour Factor	0.8400	0.8400	0.8400	0.8400	0.8400	0.8400
Other Adjustment Factor	1.0000	1.0000	1.0000	1.0000	1.0000	1.0000
Total 15-Minute Volume [veh/h]	109	55	104	192	167	149
Total Analysis Volume [veh/h]	435	220	417	767	669	598
Presence of On-Street Parking	No	No	No	No	No	No
On-Street Parking Maneuver Rate [/h]	0	0	0	0	0	0
Local Bus Stopping Rate [/h]	0	0	0	0	0	0
v_do, Outbound Pedestrian Volume crossing	0		2		2	
v_di, Inbound Pedestrian Volume crossing m	0		2		2	
v_co, Outbound Pedestrian Volume crossing	0		0		1	
v_ci, Inbound Pedestrian Volume crossing mi	1		0		0	
v_ab, Corner Pedestrian Volume [ped/h]	0		0		0	
Bicycle Volume [bicycles/h]	0		0		2	



**Intersection Settings**

Located in CBD	No
Signal Coordination Group	-
Cycle Length [s]	90
Active Pattern	Free Running (No Pattern)
Coordination Type	<i>Free Running</i>
Actuation Type	<i>Fully actuated</i>
Offset [s]	0.0
Offset Reference	Lead Green - Beginning of First Green
Permissive Mode	SingleBand
Lost time [s]	9.00

**Phasing & Timing (Basic)**

Control Type	Permissive	Permissive	Protected	Permissive	Permissive	Permissive
Signal Group	4	0	7	8	6	0
Auxiliary Signal Groups						
Maximum Green [s]	30	0	20	30	24	0
Amber [s]	4.3	0.0	3.5	4.3	4.0	0.0
All red [s]	1.0	0.0	1.0	1.0	1.0	0.0
Walk [s]	0	0	0	4	4	0
Pedestrian Clearance [s]	0	0	0	20	34	0
Delayed Vehicle Green [s]	0.0	0.0	0.0	0.0	0.0	0.0
Rest In Walk	No			No	No	
I1, Start-Up Lost Time [s]	2.0	0.0	2.0	2.0	2.0	0.0
I2, Clearance Lost Time [s]	2.0	0.0	2.0	2.0	2.0	0.0
Detector Location [ft]	0.0	0.0	0.0	0.0	0.0	0.0
Detector Length [ft]	20.0	0.0	20.0	20.0	20.0	0.0
I, Upstream Filtering Factor	1.00	1.00	1.00	1.00	1.00	1.00

**Phasing & Timing: Free Running (No Pattern)**

Split [s]	14	0	9	14	9	0
Lead / Lag	-	-	Lead	-	Lead	-
Minimum Green [s]	10	0	5	10	5	0
Vehicle Extension [s]	3.0	0.0	3.0	3.0	3.0	0.0
Minimum Recall	Yes		No	Yes	No	
Maximum Recall	No		No	No	No	
Pedestrian Recall	No		No	No	No	

**Exclusive Pedestrian Phase**

Pedestrian Signal Group	0
Pedestrian Walk [s]	0
Pedestrian Clearance [s]	0



**Lane Group Calculations**

Lane Group	C	R	L	C	L	R
C, Cycle Length [s]	70	70	70	70	70	70
L, Total Lost Time per Cycle [s]	4.00	4.00	4.00	4.00	4.00	4.00
l1_p, Permitted Start-Up Lost Time [s]	0.00	0.00	0.00	0.00	0.00	0.00
l2, Clearance Lost Time [s]	2.00	2.00	2.00	2.00	2.00	2.00
g_i, Effective Green Time [s]	14	14	18	37	25	25
g / C, Green / Cycle	0.21	0.21	0.26	0.53	0.36	0.36
(v / s)_i Volume / Saturation Flow Rate	0.09	0.14	0.23	0.15	0.19	0.38
s, saturation flow rate [veh/h]	5057	1606	1805	5151	3514	1580
c, Capacity [veh/h]	1043	331	477	2719	1257	565
d1, Uniform Delay [s]	24.09	25.50	24.59	9.15	17.80	22.24
k, delay calibration	0.11	0.11	0.29	0.11	0.11	0.50
l, Upstream Filtering Factor	1.00	1.00	1.00	1.00	1.00	1.00
d2, Incremental Delay [s]	0.27	2.29	12.48	0.06	0.35	54.22
d3, Initial Queue Delay [s]	0.00	0.00	0.00	0.00	0.00	0.00
Rp, platoon ratio	1.00	1.00	1.00	1.00	1.00	1.00
PF, progression factor	1.00	1.00	1.00	1.00	1.00	1.00

**Lane Group Results**

X, volume / capacity	0.42	0.66	0.87	0.28	0.53	1.06
d, Delay for Lane Group [s/veh]	24.36	27.79	37.07	9.21	18.16	76.46
Lane Group LOS	C	C	D	A	B	F
Critical Lane Group	No	Yes	Yes	No	No	Yes
50th-Percentile Queue Length [veh/ln]	2.01	3.40	7.82	1.90	4.00	16.83
50th-Percentile Queue Length [ft/ln]	50.24	84.93	195.62	47.53	100.12	420.79
95th-Percentile Queue Length [veh/ln]	3.62	6.11	12.41	3.42	7.21	24.45
95th-Percentile Queue Length [ft/ln]	90.43	152.87	310.30	85.56	180.22	611.31

**Movement, Approach, & Intersection Results**

d_M, Delay for Movement [s/veh]	24.36	27.79	37.07	9.21	18.16	76.46
Movement LOS	C	C	D	A	B	F
d_A, Approach Delay [s/veh]	25.51		19.02		45.68	
Approach LOS	C		B		D	
d_I, Intersection Delay [s/veh]	31.26					
Intersection LOS	C					
Intersection V/C	0.857					

**Emissions**

Vehicle Miles Traveled [mph]	109.41	55.33	36.59	67.29	80.22	71.71
Stops [stops/h]	311.17	175.35	403.88	294.43	413.44	868.79
Fuel consumption [US gal/h]	8.38	4.49	6.88	5.83	8.06	17.06
CO [g/h]	585.70	313.91	481.15	407.85	563.28	1192.21
NOx [g/h]	113.96	61.07	93.61	79.35	109.59	231.96
VOC [g/h]	135.74	72.75	111.51	94.52	130.55	276.31

**Other Modes**

g_Walk,mi, Effective Walk Time [s]	8.0		8.0		8.7	
M_corner, Corner Circulation Area [ft <sup>2</sup> /ped]	0.00		0.00		0.00	
M_CW, Crosswalk Circulation Area [ft <sup>2</sup> /ped]	0.00		0.00		0.00	
d_p, Pedestrian Delay [s]	27.33		27.33		26.71	
I_p,int, Pedestrian LOS Score for Intersectio	2.875		2.893		2.584	
Crosswalk LOS	C		C		B	
s_b, Saturation Flow Rate of the bicycle lane	2000		2000		2000	
c_b, Capacity of the bicycle lane [bicycles/h]	860		860		688	
d_b, Bicycle Delay [s]	11.32		11.32		15.02	
I_b,int, Bicycle LOS Score for Intersection	1.920		2.211		1.560	
Bicycle LOS	A		B		A	

**Sequence**

Ring 1	-	-	-	8	-	-	-	-	-	-	-	-	-	-	-	-
Ring 2	-	6	7	4	-	-	-	-	-	-	-	-	-	-	-	-
Ring 3	-	-	-	-	-	-	-	-	-	-	-	-	-	-	-	-
Ring 4	-	-	-	-	-	-	-	-	-	-	-	-	-	-	-	-

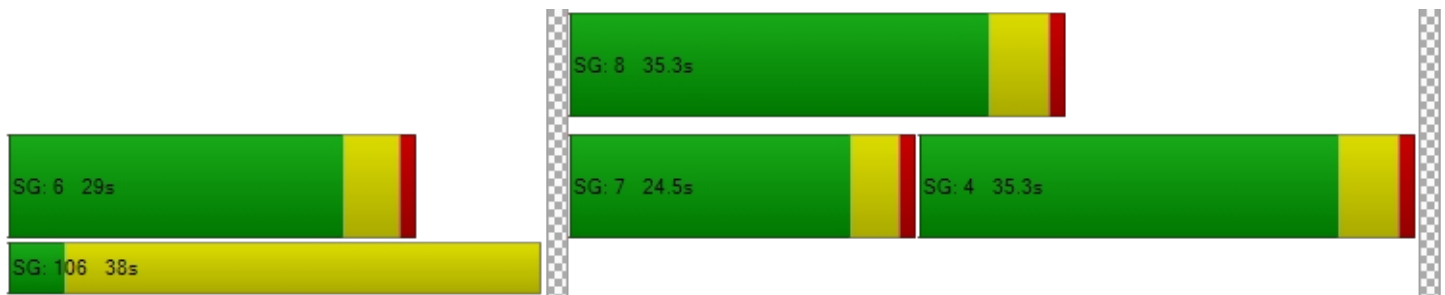

**Intersection Level Of Service Report**  
**Intersection 8: Fallon Road & Central Parkway**

Control Type:	Signalized	Delay (sec / veh):	32.1
Analysis Method:	HCM 7th Edition	Level Of Service:	C
Analysis Period:	15 minutes	Volume to Capacity (v/c):	0.572

**Intersection Setup**

Name	Fallon Road			Fallon Road			Central Parkway			Central Parkway		
Approach	Northbound			Southbound			Eastbound			Westbound		
Lane Configuration	[Diagram]			[Diagram]			[Diagram]			[Diagram]		
Turning Movement	Left	Thru	Right	Left	Thru	Right	Left	Thru	Right	Left	Thru	Right
Lane Width [ft]	12.00	12.00	12.00	12.00	12.00	12.00	12.00	12.00	12.00	12.00	12.00	12.00
No. of Lanes in Entry Pocket	2	0	1	1	0	1	2	0	2	2	0	1
Entry Pocket Length [ft]	300.00	100.00	255.00	295.00	100.00	245.00	350.00	100.00	230.00	250.00	100.00	250.00
No. of Lanes in Exit Pocket	0	0	1	0	0	2	0	0	0	0	0	0
Exit Pocket Length [ft]	0.00	0.00	250.00	0.00	0.00	500.00	0.00	0.00	0.00	0.00	0.00	0.00
Speed [mph]	40.00			30.00			25.00			30.00		
Grade [%]	0.00			0.00			0.00			0.00		
Curb Present	Yes			Yes			Yes			Yes		
Crosswalk	Yes			Yes			Yes			Yes		



**Volumes**

Name	Fallon Road			Fallon Road			Central Parkway			Central Parkway		
Base Volume Input [veh/h]	55	538	140	73	978	59	52	175	91	277	181	83
Base Volume Adjustment Factor	1.0000	1.0000	1.0000	1.0000	1.0000	1.0000	1.0000	1.0000	1.0000	1.0000	1.0000	1.0000
Heavy Vehicles Percentage [%]	6.00	1.20	0.70	0.00	0.40	1.80	0.00	0.60	3.30	0.00	0.60	1.20
Proportion of CAVs [%]	0.00											
Growth Factor	1.0000	1.0000	1.0000	1.0000	1.0000	1.0000	1.0000	1.0000	1.0000	1.0000	1.0000	1.0000
In-Process Volume [veh/h]	0	0	0	0	0	0	0	0	0	0	0	0
Site-Generated Trips [veh/h]	0	0	0	0	0	0	0	0	0	0	0	0
Diverted Trips [veh/h]	0	0	0	0	0	0	0	0	0	0	0	0
Pass-by Trips [veh/h]	0	0	0	0	0	0	0	0	0	0	0	0
Existing Site Adjustment Volume [veh/h]	0	0	0	0	0	0	0	0	0	0	0	0
Other Volume [veh/h]	0	0	0	0	0	0	0	0	0	0	0	0
Right Turn on Red Volume [veh/h]	0	0	0	0	0	0	0	0	0	0	0	0
Total Hourly Volume [veh/h]	55	538	140	73	978	59	52	175	91	277	181	83
Peak Hour Factor	0.7500	0.7500	0.7500	0.7500	0.7500	0.7500	0.7500	0.7500	0.7500	0.7500	0.7500	0.7500
Other Adjustment Factor	1.0000	1.0000	1.0000	1.0000	1.0000	1.0000	1.0000	1.0000	1.0000	1.0000	1.0000	1.0000
Total 15-Minute Volume [veh/h]	18	179	47	24	326	20	17	58	30	92	60	28
Total Analysis Volume [veh/h]	73	717	187	97	1304	79	69	233	121	369	241	111
Presence of On-Street Parking	No		No	No		No	No		No	No		No
On-Street Parking Maneuver Rate [/h]	0	0	0	0	0	0	0	0	0	0	0	0
Local Bus Stopping Rate [/h]	0	0	0	0	0	0	0	0	0	0	0	0
v_do, Outbound Pedestrian Volume crossing	1			2			2			1		
v_di, Inbound Pedestrian Volume crossing m	1			2			2			1		
v_co, Outbound Pedestrian Volume crossing	44			4			43			4		
v_ci, Inbound Pedestrian Volume crossing mi	43			4			44			4		
v_ab, Corner Pedestrian Volume [ped/h]	0			0			0			0		
Bicycle Volume [bicycles/h]	1			0			6			0		



**Intersection Settings**

Located in CBD	No
Signal Coordination Group	-
Cycle Length [s]	90
Active Pattern	Free Running (No Pattern)
Coordination Type	<i>Free Running</i>
Actuation Type	<i>Fully actuated</i>
Offset [s]	0.0
Offset Reference	Lead Green - Beginning of First Green
Permissive Mode	SingleBand
Lost time [s]	12.00

**Phasing & Timing (Basic)**

Control Type	Protecte	Permiss	Permiss	Protecte	Permiss	Permiss	Protecte	Permiss	Permiss	Protecte	Permiss	Permiss
Signal Group	3	8	0	7	4	0	5	2	0	1	6	0
Auxiliary Signal Groups												
Maximum Green [s]	20	30	0	20	30	0	20	30	0	20	30	0
Amber [s]	3.5	4.3	0.0	3.0	4.3	0.0	3.0	4.0	0.0	3.0	4.0	0.0
All red [s]	1.0	1.0	0.0	1.0	1.0	0.0	1.0	1.0	0.0	1.0	1.0	0.0
Walk [s]	0	4	0	0	4	0	0	4	0	0	4	0
Pedestrian Clearance [s]	0	28	0	0	34	0	0	42	0	0	41	0
Delayed Vehicle Green [s]	0.0	0.0	0.0	0.0	0.0	0.0	0.0	0.0	0.0	0.0	0.0	0.0
Rest In Walk		No			No			No			No	
I1, Start-Up Lost Time [s]	2.0	2.0	0.0	2.0	2.0	0.0	2.0	2.0	0.0	2.0	2.0	0.0
I2, Clearance Lost Time [s]	2.0	2.0	0.0	2.0	2.0	0.0	2.0	2.0	0.0	2.0	2.0	0.0
Detector Location [ft]	0.0	0.0	0.0	0.0	0.0	0.0	0.0	0.0	0.0	0.0	0.0	0.0
Detector Length [ft]	20.0	20.0	0.0	20.0	20.0	0.0	20.0	20.0	0.0	20.0	20.0	0.0
I, Upstream Filtering Factor	1.00	1.00	1.00	1.00	1.00	1.00	1.00	1.00	1.00	1.00	1.00	1.00

**Phasing & Timing: Free Running (No Pattern)**

Split [s]	0	0	0	0	0	0	0	0	0	0	0	0
Lead / Lag	Lead	-	-	Lead	-	-	Lead	-	-	Lead	-	-
Minimum Green [s]	10	12	0	10	12	0	10	12	0	10	12	0
Vehicle Extension [s]	2.0	4.0	0.0	2.0	4.0	0.0	2.0	4.0	0.0	2.0	4.0	0.0
Minimum Recall	No	Yes		No	Yes		No	No		No	No	
Maximum Recall	No	No		No	No		No	No		No	No	
Pedestrian Recall	No	No		No	No		No	No		No	No	

**Exclusive Pedestrian Phase**

Pedestrian Signal Group	0
Pedestrian Walk [s]	0
Pedestrian Clearance [s]	0





**Lane Group Calculations**

Lane Group	L	C	R	L	C	R	L	C	R	L	C	R
C, Cycle Length [s]	100	100	100	100	100	100	100	100	100	100	100	100
L, Total Lost Time per Cycle [s]	4.00	4.00	4.00	4.00	4.00	4.00	4.00	4.00	4.00	4.00	4.00	4.00
l1_p, Permitted Start-Up Lost Time [s]	0.00	0.00	0.00	0.00	0.00	0.00	0.00	0.00	0.00	0.00	0.00	0.00
l2, Clearance Lost Time [s]	2.00	2.00	2.00	2.00	2.00	2.00	2.00	2.00	2.00	2.00	2.00	2.00
g_i, Effective Green Time [s]	9	31	31	9	31	31	9	31	31	13	35	35
g / C, Green / Cycle	0.09	0.31	0.31	0.09	0.31	0.31	0.09	0.31	0.31	0.13	0.35	0.35
(v / s)_i Volume / Saturation Flow Rate	0.02	0.14	0.12	0.05	0.25	0.05	0.02	0.12	0.05	0.11	0.13	0.07
s, saturation flow rate [veh/h]	3348	5127	1567	1810	5159	1586	3514	1891	2511	3514	1891	1589
c, Capacity [veh/h]	312	1572	481	171	1589	488	304	586	779	453	666	560
d1, Uniform Delay [s]	42.02	27.93	27.19	43.32	32.04	25.19	42.53	27.13	24.87	42.39	24.03	22.53
k, delay calibration	0.04	0.15	0.15	0.04	0.15	0.15	0.04	0.15	0.15	0.04	0.15	0.15
l, Upstream Filtering Factor	1.00	1.00	1.00	1.00	1.00	1.00	1.00	1.00	1.00	1.00	1.00	1.00
d2, Incremental Delay [s]	0.14	0.30	0.73	1.11	1.57	0.22	0.14	0.62	0.13	1.39	0.47	0.24
d3, Initial Queue Delay [s]	0.00	0.00	0.00	0.00	0.00	0.00	0.00	0.00	0.00	0.00	0.00	0.00
Rp, platoon ratio	1.00	1.00	1.00	1.00	1.00	1.00	1.00	1.00	1.00	1.00	1.00	1.00
PF, progression factor	1.00	1.00	1.00	1.00	1.00	1.00	1.00	1.00	1.00	1.00	1.00	1.00

**Lane Group Results**

X, volume / capacity	0.23	0.46	0.39	0.57	0.82	0.16	0.23	0.40	0.16	0.82	0.36	0.20
d, Delay for Lane Group [s/veh]	42.16	28.23	27.92	44.42	33.61	25.41	42.67	27.75	25.00	43.77	24.50	22.78
Lane Group LOS	D	C	C	D	C	C	D	C	C	D	C	C
Critical Lane Group	Yes	No	No	No	Yes	No	No	Yes	No	Yes	No	No
50th-Percentile Queue Length [veh/ln]	0.82	4.45	3.46	2.33	9.71	1.38	0.80	4.47	1.05	4.47	4.24	1.83
50th-Percentile Queue Length [ft/ln]	20.49	111.35	86.44	58.25	242.68	34.60	20.09	111.76	26.35	111.82	106.10	45.83
95th-Percentile Queue Length [veh/ln]	1.48	7.92	6.22	4.19	14.82	2.49	1.45	7.94	1.90	7.94	7.62	3.30
95th-Percentile Queue Length [ft/ln]	36.89	197.88	155.59	104.85	370.42	62.28	36.16	198.44	47.43	198.53	190.56	82.49



**Movement, Approach, & Intersection Results**

d_M, Delay for Movement [s/veh]	42.16	28.23	27.92	44.42	33.61	25.41	42.67	27.75	25.00	43.77	24.50	22.78
Movement LOS	D	C	C	D	C	C	D	C	C	D	C	C
d_A, Approach Delay [s/veh]	29.21			33.88			29.40			34.10		
Approach LOS	C			C			C			C		
d_I, Intersection Delay [s/veh]	32.13											
Intersection LOS	C											
Intersection V/C	0.572											

**Emissions**

Vehicle Miles Traveled [mph]	19.33	189.84	49.51	24.40	327.97	19.87	6.03	20.36	10.58	83.89	54.79	25.23
Stops [stops/h]	59.16	482.21	124.78	84.08	1050.96	49.94	57.99	161.32	76.07	322.82	153.15	66.15
Fuel consumption [US gal/h]	1.90	15.66	4.06	2.35	28.23	1.50	1.09	2.85	1.38	8.52	4.30	1.92
CO [g/h]	132.80	1094.34	283.93	163.96	1972.93	105.01	76.39	199.25	96.67	595.80	300.80	134.12
NOx [g/h]	25.84	212.92	55.24	31.90	383.86	20.43	14.86	38.77	18.81	115.92	58.52	26.10
VOC [g/h]	30.78	253.62	65.80	38.00	457.25	24.34	17.70	46.18	22.40	138.08	69.71	31.08

**Other Modes**

g_Walk,mi, Effective Walk Time [s]	8.0			8.0			8.0			8.0		
M_corner, Corner Circulation Area [ft <sup>2</sup> /ped]	0.00			0.00			0.00			0.00		
M_CW, Crosswalk Circulation Area [ft <sup>2</sup> /ped]	0.00			0.00			0.00			0.00		
d_p, Pedestrian Delay [s]	42.20			42.20			42.20			42.20		
I_p,int, Pedestrian LOS Score for Intersectio	3.257			3.206			2.696			2.549		
Crosswalk LOS	C			C			B			B		
s_b, Saturation Flow Rate of the bicycle lane	2000			2000			2000			2000		
c_b, Capacity of the bicycle lane [bicycles/h]	601			601			601			601		
d_b, Bicycle Delay [s]	24.40			24.39			24.46			24.39		
I_b,int, Bicycle LOS Score for Intersection	2.097			2.374			2.258			2.749		
Bicycle LOS	B			B			B			B		

**Sequence**

Ring 1	1	2	3	4	-	-	-	-	-	-	-	-	-	-	-
Ring 2	5	6	7	8	-	-	-	-	-	-	-	-	-	-	-
Ring 3	-	-	-	-	-	-	-	-	-	-	-	-	-	-	-
Ring 4	-	-	-	-	-	-	-	-	-	-	-	-	-	-	-

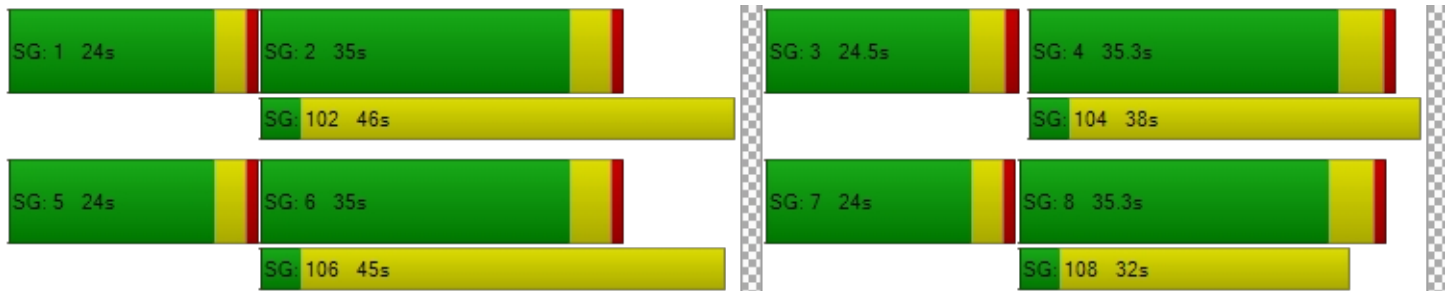

**Intersection Level Of Service Report**  
**Intersection 9: Fallon Road & Dublin Boulevard**

Control Type:	Signalized	Delay (sec / veh):	23.2
Analysis Method:	HCM 7th Edition	Level Of Service:	C
Analysis Period:	15 minutes	Volume to Capacity (v/c):	0.545

**Intersection Setup**

Name	Fallon Road			Fallon Road			Dublin Boulevard			Dublin Boulevard		
Approach	Northbound			Southbound			Eastbound			Westbound		
Lane Configuration	T T T			T T T			T T T T			T T		
Turning Movement	Left	Thru	Right	Left	Thru	Right	Left	Thru	Right	Left	Thru	Right
Lane Width [ft]	12.00	12.00	12.00	12.00	12.00	12.00	12.00	12.00	12.00	12.00	12.00	12.00
No. of Lanes in Entry Pocket	2	0	0	1	0	1	1	0	1	0	0	0
Entry Pocket Length [ft]	430.00	100.00	100.00	140.00	100.00	225.00	400.00	100.00	400.00	100.00	100.00	100.00
No. of Lanes in Exit Pocket	0	0	0	0	0	0	0	0	1	0	0	0
Exit Pocket Length [ft]	0.00	0.00	0.00	0.00	0.00	0.00	0.00	0.00	500.00	0.00	0.00	0.00
Speed [mph]	45.00			45.00			45.00			45.00		
Grade [%]	0.00			0.00			0.00			0.00		
Curb Present	Yes			Yes			Yes			Yes		
Crosswalk	No			No			Yes			Yes		



**Volumes**

Name	Fallon Road			Fallon Road			Dublin Boulevard			Dublin Boulevard		
Base Volume Input [veh/h]	243	501	29	2	1151	210	134	20	198	8	2	25
Base Volume Adjustment Factor	1.0000	1.0000	1.0000	1.0000	1.0000	1.0000	1.0000	1.0000	1.0000	1.0000	1.0000	1.0000
Heavy Vehicles Percentage [%]	3.50	1.20	4.00	1.00	0.50	0.00	0.70	4.00	3.50	1.00	1.00	1.00
Proportion of CAVs [%]	0.00											
Growth Factor	1.0000	1.0000	1.0000	1.0000	1.0000	1.0000	1.0000	1.0000	1.0000	1.0000	1.0000	1.0000
In-Process Volume [veh/h]	0	0	0	0	0	0	0	0	0	0	0	0
Site-Generated Trips [veh/h]	0	0	0	0	0	0	0	0	0	0	0	0
Diverted Trips [veh/h]	0	0	0	0	0	0	0	0	0	0	0	0
Pass-by Trips [veh/h]	0	0	0	0	0	0	0	0	0	0	0	0
Existing Site Adjustment Volume [veh/h]	0	0	0	0	0	0	0	0	0	0	0	0
Other Volume [veh/h]	0	0	0	0	0	0	0	0	0	0	0	0
Right Turn on Red Volume [veh/h]	0	0	0	0	0	0	0	0	0	0	0	0
Total Hourly Volume [veh/h]	243	501	29	2	1151	210	134	20	198	8	2	25
Peak Hour Factor	0.9200	0.9200	0.9400	0.9400	0.9200	0.9200	0.9200	0.9400	0.9200	0.9400	0.9400	0.9400
Other Adjustment Factor	1.0000	1.0000	1.0000	1.0000	1.0000	1.0000	1.0000	1.0000	1.0000	1.0000	1.0000	1.0000
Total 15-Minute Volume [veh/h]	66	136	8	1	313	57	36	5	54	2	1	7
Total Analysis Volume [veh/h]	264	545	31	2	1251	228	146	21	215	9	2	27
Presence of On-Street Parking	No		No	No		No	No		No	No		No
On-Street Parking Maneuver Rate [/h]	0	0	0	0	0	0	0	0	0	0	0	0
Local Bus Stopping Rate [/h]	0	0	0	0	0	0	0	0	0	0	0	0
v_do, Outbound Pedestrian Volume crossing	0			0			0			0		
v_di, Inbound Pedestrian Volume crossing m	0			0			0			0		
v_co, Outbound Pedestrian Volume crossing	2			4			4			3		
v_ci, Inbound Pedestrian Volume crossing mi	3			4			4			2		
v_ab, Corner Pedestrian Volume [ped/h]	0			0			0			0		
Bicycle Volume [bicycles/h]	0			0			0			0		



**Intersection Settings**

Located in CBD	No
Signal Coordination Group	-
Cycle Length [s]	140
Active Pattern	Pattern 1
Coordination Type	Time of Day Pattern Isolated
Actuation Type	Fully actuated
Offset [s]	0.0
Offset Reference	Lead Green - Beginning of First Green
Permissive Mode	SingleBand
Lost time [s]	12.00

**Phasing & Timing (Basic)**

Control Type	Protecte	Permiss	Permiss	Protecte	Permiss	Permiss	Protecte	Permiss	Overlap	Protecte	Permiss	Permiss
Signal Group	3	8	0	7	4	0	5	2	2	1	6	0
Auxiliary Signal Groups									2,3			
Maximum Green [s]	30	30	0	12	30	0	30	30	30	12	12	0
Amber [s]	4.3	4.7	0.0	4.3	4.7	0.0	4.3	4.3	4.3	3.0	4.8	0.0
All red [s]	1.0	1.0	0.0	1.0	1.0	0.0	1.0	1.0	1.0	1.0	1.0	0.0
Walk [s]	0	0	0	0	4	0	0	0	0	0	0	0
Pedestrian Clearance [s]	0	0	0	0	41	0	0	0	0	0	0	0
Delayed Vehicle Green [s]	0.0	0.0	0.0	0.0	0.0	0.0	0.0	0.0	0.0	0.0	0.0	0.0
Rest In Walk		No			No			No			No	
I1, Start-Up Lost Time [s]	2.0	2.0	0.0	2.0	2.0	0.0	2.0	2.0	2.0	2.0	2.0	0.0
I2, Clearance Lost Time [s]	2.0	2.0	0.0	2.0	2.0	0.0	2.0	2.0	2.0	2.0	2.0	0.0
Detector Location [ft]	0.0	0.0	0.0	0.0	0.0	0.0	0.0	0.0	0.0	0.0	0.0	0.0
Detector Length [ft]	20.0	20.0	0.0	20.0	20.0	0.0	0.0	0.0	0.0	20.0	20.0	0.0
I, Upstream Filtering Factor	1.00	1.00	1.00	1.00	1.00	1.00	1.00	1.00	1.00	1.00	1.00	1.00

**Phasing & Timing: Pattern 1**

Split [s]	35	65	0	20	50	0	35	35	35	20	20	0
Lead / Lag	Lead	-	-	Lead	-	-	Lead	-	-	Lead	-	-
Minimum Green [s]	10	12	0	10	12	0	10	12	12	10	10	0
Vehicle Extension [s]	2.0	4.0	0.0	2.0	4.0	0.0	2.0	4.0	4.0	2.0	2.0	0.0
Minimum Recall	No	Yes		No	Yes		No	No	No	No	No	
Maximum Recall	No	No		No	No		No	No	No	No	No	
Pedestrian Recall	No	No		No	No		No	No	No	No	No	

**Exclusive Pedestrian Phase**

Pedestrian Signal Group	0
Pedestrian Walk [s]	0
Pedestrian Clearance [s]	0



**Lane Group Calculations**

Lane Group	L	C	C	L	C	R	L	C	R	L	C
C, Cycle Length [s]	140	140	140	140	140	140	140	140	140	140	140
L, Total Lost Time per Cycle [s]	4.00	4.00	4.00	4.00	4.00	4.00	4.00	4.00	4.00	4.00	4.00
l1_p, Permitted Start-Up Lost Time [s]	0.00	0.00	0.00	0.00	0.00	0.00	0.00	0.00	0.00	0.00	0.00
l2, Clearance Lost Time [s]	2.00	2.00	2.00	2.00	2.00	2.00	2.00	2.00	0.00	2.00	2.00
g_i, Effective Green Time [s]	15	102	102	2	89	89	11	17	36	3	9
g / C, Green / Cycle	0.11	0.73	0.73	0.01	0.64	0.64	0.08	0.12	0.26	0.02	0.06
(v / s)_i Volume / Saturation Flow Rate	0.08	0.15	0.15	0.00	0.35	0.14	0.04	0.01	0.08	0.01	0.02
s, saturation flow rate [veh/h]	3417	1882	1846	1795	3603	1609	3495	1840	2780	1795	1619
c, Capacity [veh/h]	369	1372	1346	27	2291	1023	282	222	690	38	99
d1, Uniform Delay [s]	60.34	6.08	6.08	68.01	14.23	10.82	61.71	54.73	42.88	67.39	62.81
k, delay calibration	0.04	0.50	0.50	0.04	0.50	0.50	0.04	0.15	0.15	0.04	0.04
l, Upstream Filtering Factor	1.00	1.00	1.00	1.00	1.00	1.00	1.00	1.00	1.00	1.00	1.00
d2, Incremental Delay [s]	0.97	0.35	0.36	0.44	0.94	0.50	0.55	0.26	0.36	1.17	0.60
d3, Initial Queue Delay [s]	0.00	0.00	0.00	0.00	0.00	0.00	0.00	0.00	0.00	0.00	0.00
Rp, platoon ratio	1.00	1.00	1.00	1.00	1.00	1.00	1.00	1.00	1.00	1.00	1.00
PF, progression factor	1.00	1.00	1.00	1.00	1.00	1.00	1.00	1.00	1.00	1.00	1.00

**Lane Group Results**

X, volume / capacity	0.72	0.21	0.21	0.08	0.55	0.22	0.52	0.09	0.31	0.24	0.29
d, Delay for Lane Group [s/veh]	61.31	6.43	6.44	68.45	15.17	11.32	62.26	54.99	43.25	68.56	63.41
Lane Group LOS	E	A	A	E	B	B	E	D	D	E	E
Critical Lane Group	Yes	No	No	No	Yes	No	No	No	Yes	Yes	No
50th-Percentile Queue Length [veh/ln]	4.50	2.53	2.48	0.07	10.45	2.96	2.47	0.67	3.03	0.32	0.99
50th-Percentile Queue Length [ft/ln]	112.54	63.22	62.12	1.82	261.25	73.89	61.83	16.67	75.66	8.11	24.73
95th-Percentile Queue Length [veh/ln]	7.98	4.55	4.47	0.13	15.75	5.32	4.45	1.20	5.45	0.58	1.78
95th-Percentile Queue Length [ft/ln]	199.53	113.79	111.82	3.28	393.79	133.00	111.30	30.00	136.19	14.60	44.52



**Movement, Approach, & Intersection Results**

d_M, Delay for Movement [s/veh]	61.31	6.44	6.44	68.45	15.17	11.32	62.26	54.99	43.25	68.56	63.41	63.41
Movement LOS	E	A	A	E	B	B	E	D	D	E	E	E
d_A, Approach Delay [s/veh]	23.68			14.65			51.16			64.63		
Approach LOS	C			B			D			E		
d_I, Intersection Delay [s/veh]	23.20											
Intersection LOS	C											
Intersection V/C	0.545											

**Emissions**

Vehicle Miles Traveled [mph]	35.46	39.04	38.32	0.53	331.23	60.37	175.66	25.27	258.68	2.02	6.51
Stops [stops/h]	231.54	65.03	63.90	1.87	537.48	76.01	127.22	17.14	155.67	8.34	25.44
Fuel consumption [US gal/h]	7.39	2.53	2.48	0.07	21.90	3.54	9.45	1.31	12.69	0.30	0.91
CO [g/h]	516.41	176.66	173.50	4.84	1530.72	247.42	660.74	91.86	887.33	20.87	63.86
NOx [g/h]	100.47	34.37	33.76	0.94	297.82	48.14	128.56	17.87	172.64	4.06	12.42
VOC [g/h]	119.68	40.94	40.21	1.12	354.76	57.34	153.13	21.29	205.65	4.84	14.80

**Other Modes**

g_Walk,mi, Effective Walk Time [s]	0.0			0.0			8.0			59.3		
M_corner, Corner Circulation Area [ft <sup>2</sup> /ped]	0.00			0.00			0.00			0.00		
M_CW, Crosswalk Circulation Area [ft <sup>2</sup> /ped]	0.00			0.00			384.19			0.00		
d_p, Pedestrian Delay [s]	0.00			0.00			62.22			23.25		
I_p,int, Pedestrian LOS Score for Intersectio	0.000			0.000			2.909			2.148		
Crosswalk LOS	F			F			C			B		
s_b, Saturation Flow Rate of the bicycle lane	2000			2000			2000			2000		
c_b, Capacity of the bicycle lane [bicycles/h]	847			633			424			203		
d_b, Bicycle Delay [s]	23.25			32.70			43.44			56.51		
I_b,int, Bicycle LOS Score for Intersection	2.253			2.781			2.190			1.622		
Bicycle LOS	B			C			B			A		

**Sequence**

Ring 1	1	2	3	4	-	-	-	-	-	-	-	-	-	-	-
Ring 2	5	6	7	8	-	-	-	-	-	-	-	-	-	-	-
Ring 3	-	-	-	-	-	-	-	-	-	-	-	-	-	-	-
Ring 4	-	-	-	-	-	-	-	-	-	-	-	-	-	-	-



**Intersection Level Of Service Report**  
**Intersection 10: Fallon Road & Fallon Gateway**

Control Type:	Signalized	Delay (sec / veh):	13.1
Analysis Method:	HCM 7th Edition	Level Of Service:	B
Analysis Period:	15 minutes	Volume to Capacity (v/c):	0.527

**Intersection Setup**

Name	Fallon Road		Fallon Road		Fallon Gateway	
Approach	Northbound		Southbound		Eastbound	
Lane Configuration	⇐⇐		⇐		⇐⇐⇐⇐	
Turning Movement	Left	Thru	Thru	Right	Left	Right
Lane Width [ft]	12.00	12.00	12.00	12.00	12.00	12.00
No. of Lanes in Entry Pocket	1	0	0	0	1	1
Entry Pocket Length [ft]	275.00	100.00	100.00	100.00	210.00	210.00
No. of Lanes in Exit Pocket	0	0	0	0	0	0
Exit Pocket Length [ft]	0.00	0.00	0.00	0.00	0.00	0.00
Speed [mph]	45.00		40.00		25.00	
Grade [%]	0.00		0.00		0.00	
Curb Present	Yes		Yes		Yes	
Crosswalk	No		No		Yes	





**Volumes**

Name	Fallon Road		Fallon Road		Fallon Gateway	
Base Volume Input [veh/h]	182	707	1178	42	20	94
Base Volume Adjustment Factor	1.0000	1.0000	1.0000	1.0000	1.0000	1.0000
Heavy Vehicles Percentage [%]	1.70	4.10	1.00	0.00	0.00	4.30
Proportion of CAVs [%]	0.00					
Growth Factor	1.0000	1.0000	1.0000	1.0000	1.0000	1.0000
In-Process Volume [veh/h]	0	0	0	0	0	0
Site-Generated Trips [veh/h]	0	0	0	0	0	0
Diverted Trips [veh/h]	0	0	0	0	0	0
Pass-by Trips [veh/h]	0	0	0	0	0	0
Existing Site Adjustment Volume [veh/h]	0	0	0	0	0	0
Other Volume [veh/h]	0	0	0	0	0	0
Right Turn on Red Volume [veh/h]	0	0	0	0	0	0
Total Hourly Volume [veh/h]	182	707	1178	42	20	94
Peak Hour Factor	0.9000	0.9000	0.9000	0.9000	0.9000	0.9000
Other Adjustment Factor	1.0000	1.0000	1.0000	1.0000	1.0000	1.0000
Total 15-Minute Volume [veh/h]	51	196	327	12	6	26
Total Analysis Volume [veh/h]	202	786	1309	47	22	104
Presence of On-Street Parking	No	No	No	No	No	No
On-Street Parking Maneuver Rate [/h]	0	0	0	0	0	0
Local Bus Stopping Rate [/h]	0	0	0	0	0	0
v_do, Outbound Pedestrian Volume crossing	0		0		0	
v_di, Inbound Pedestrian Volume crossing m	0		0		0	
v_co, Outbound Pedestrian Volume crossing	0		0		0	
v_ci, Inbound Pedestrian Volume crossing mi	0		0		0	
v_ab, Corner Pedestrian Volume [ped/h]	0		0		0	
Bicycle Volume [bicycles/h]	0		0		0	



**Intersection Settings**

Located in CBD	No
Signal Coordination Group	-
Cycle Length [s]	105
Active Pattern	Pattern 1
Coordination Type	Time of Day Pattern Isolated
Actuation Type	Fully actuated
Offset [s]	0.0
Offset Reference	Lead Green - Beginning of First Green
Permissive Mode	SingleBand
Lost time [s]	9.00

**Phasing & Timing (Basic)**

Control Type	Protected	Permissive	Permissive	Permissive	Permissive	Overlap
Signal Group	3	8	4	0	2	2
Auxiliary Signal Groups						2,3
Maximum Green [s]	20	40	40	0	30	30
Amber [s]	3.5	4.7	4.7	0.0	3.5	3.5
All red [s]	1.0	1.0	1.0	0.0	1.0	1.0
Walk [s]	0	0	4	0	0	0
Pedestrian Clearance [s]	0	0	28	0	0	0
Delayed Vehicle Green [s]	0.0	0.0	0.0	0.0	0.0	0.0
Rest In Walk		No	No		No	
I1, Start-Up Lost Time [s]	2.0	2.0	2.0	0.0	2.0	2.0
I2, Clearance Lost Time [s]	2.5	3.7	3.7	0.0	2.5	2.5
Detector Location [ft]	0.0	0.0	0.0	0.0	0.0	0.0
Detector Length [ft]	20.0	20.0	0.0	0.0	20.0	20.0
I, Upstream Filtering Factor	1.00	1.00	1.00	1.00	1.00	1.00

**Phasing & Timing: Pattern 1**

Split [s]	25	70	45	0	35	35
Lead / Lag	Lead	-	-	-	Lead	-
Minimum Green [s]	10	10	10	0	10	10
Vehicle Extension [s]	2.0	5.0	5.0	0.0	2.0	2.0
Minimum Recall	No	Yes	Yes		No	No
Maximum Recall	No	No	No		No	No
Pedestrian Recall	No	No	No		No	No

**Exclusive Pedestrian Phase**

Pedestrian Signal Group	0
Pedestrian Walk [s]	0
Pedestrian Clearance [s]	0



**Lane Group Calculations**

Lane Group	L	C	C	C	L	R
C, Cycle Length [s]	64	64	64	64	64	64
L, Total Lost Time per Cycle [s]	4.50	5.70	5.70	5.70	4.50	4.50
l1_p, Permitted Start-Up Lost Time [s]	0.00	0.00	0.00	0.00	0.00	0.00
l2, Clearance Lost Time [s]	2.50	3.70	3.70	3.70	2.50	0.00
g_i, Effective Green Time [s]	10	45	31	31	9	23
g / C, Green / Cycle	0.15	0.70	0.48	0.48	0.14	0.36
(v / s)_i Volume / Saturation Flow Rate	0.06	0.22	0.36	0.36	0.01	0.04
s, saturation flow rate [veh/h]	3467	3500	1885	1862	3514	2761
c, Capacity [veh/h]	525	2456	905	894	491	998
d1, Uniform Delay [s]	24.60	3.69	13.58	13.67	23.96	13.64
k, delay calibration	0.04	0.23	0.25	0.25	0.04	0.04
l, Upstream Filtering Factor	1.00	1.00	1.00	1.00	1.00	1.00
d2, Incremental Delay [s]	0.17	0.16	2.86	3.08	0.01	0.02
d3, Initial Queue Delay [s]	0.00	0.00	0.00	0.00	0.00	0.00
Rp, platoon ratio	1.00	1.00	1.00	1.00	1.00	1.00
PF, progression factor	1.00	1.00	1.00	1.00	1.00	1.00

**Lane Group Results**

X, volume / capacity	0.38	0.32	0.75	0.76	0.04	0.10
d, Delay for Lane Group [s/veh]	24.77	3.85	16.44	16.75	23.97	13.66
Lane Group LOS	C	A	B	B	C	B
Critical Lane Group	Yes	No	No	Yes	No	Yes
50th-Percentile Queue Length [veh/ln]	1.25	0.95	7.01	7.10	0.14	0.47
50th-Percentile Queue Length [ft/ln]	31.35	23.67	175.33	177.54	3.54	11.87
95th-Percentile Queue Length [veh/ln]	2.26	1.70	11.36	11.47	0.25	0.85
95th-Percentile Queue Length [ft/ln]	56.43	42.61	283.91	286.80	6.37	21.36

**Movement, Approach, & Intersection Results**

d_M, Delay for Movement [s/veh]	24.77	3.85	16.59	16.75	23.97	13.66
Movement LOS	C	A	B	B	C	B
d_A, Approach Delay [s/veh]	8.13		16.59		15.46	
Approach LOS	A		B		B	
d_I, Intersection Delay [s/veh]	13.15					
Intersection LOS	B					
Intersection V/C	0.527					

**Emissions**

Vehicle Miles Traveled [mph]	30.73	119.59	91.06	91.06	1.35	6.38
Stops [stops/h]	140.53	106.11	392.97	397.92	15.85	53.19
Fuel consumption [US gal/h]	3.82	6.03	9.39	9.48	0.23	0.78
CO [g/h]	266.96	421.82	656.37	662.75	16.00	54.53
NOx [g/h]	51.94	82.07	127.71	128.95	3.11	10.61
VOC [g/h]	61.87	97.76	152.12	153.60	3.71	12.64

**Other Modes**

g_Walk,mi, Effective Walk Time [s]	0.0		0.0		8.0	
M_corner, Corner Circulation Area [ft <sup>2</sup> /ped]	0.00		0.00		0.00	
M_CW, Crosswalk Circulation Area [ft <sup>2</sup> /ped]	0.00		0.00		0.00	
d_p, Pedestrian Delay [s]	0.00		0.00		24.62	
I_p,int, Pedestrian LOS Score for Intersectio	0.000		0.000		2.489	
Crosswalk LOS	F		F		B	
s_b, Saturation Flow Rate of the bicycle lane	2000		2000		2000	
c_b, Capacity of the bicycle lane [bicycles/h]	2002		1223		949	
d_b, Bicycle Delay [s]	0.00		4.84		8.86	
I_b,int, Bicycle LOS Score for Intersection	2.375		2.678		1.560	
Bicycle LOS	B		B		A	

**Sequence**

Ring 1	-	2	3	4	-	-	-	-	-	-	-	-	-	-	-	-
Ring 2	-	-	-	8	-	-	-	-	-	-	-	-	-	-	-	-
Ring 3	-	-	-	-	-	-	-	-	-	-	-	-	-	-	-	-
Ring 4	-	-	-	-	-	-	-	-	-	-	-	-	-	-	-	-



**Intersection Level Of Service Report**  
**Intersection 11: Fallon Road & I-580 WB Ramps**

Control Type:	Signalized	Delay (sec / veh):	8.7
Analysis Method:	HCM 7th Edition	Level Of Service:	A
Analysis Period:	15 minutes	Volume to Capacity (v/c):	0.750

**Intersection Setup**

Name	Fallon Road			Fallon Road			I-580 WB On-Ramp			I-580 WB Off-Ramp		
Approach	Northbound			Southbound			Eastbound			Westbound		
Lane Configuration	↑			↑↑↑						↑↑↑		
Turning Movement	Left	Thru	Right	Left	Thru	Right	Left	Thru	Right	Left	Thru	Right
Lane Width [ft]	12.00	12.00	12.00	12.00	12.00	12.00	12.00	12.00	12.00	12.00	12.00	12.00
No. of Lanes in Entry Pocket	0	0	0	0	0	1	0	0	0	1	0	1
Entry Pocket Length [ft]	100.00	100.00	100.00	100.00	100.00	225.00	100.00	100.00	100.00	170.00	100.00	130.00
No. of Lanes in Exit Pocket	0	0	1	0	0	0	0	0	1	0	0	0
Exit Pocket Length [ft]	0.00	0.00	400.00	0.00	0.00	0.00	0.00	0.00	400.00	0.00	0.00	0.00
Speed [mph]	45.00			40.00			30.00			35.00		
Grade [%]	0.00			0.00			0.00			0.00		
Curb Present	No			No						No		
Crosswalk	No			No			No			No		



**Volumes**

Name	Fallon Road			Fallon Road			I-580 WB On-Ramp			I-580 WB Off-Ramp		
	Base Volume Input [veh/h]	0	536	0	0	697	687	0	0	0	218	7
Base Volume Adjustment Factor	1.0000	1.0000	1.0000	1.0000	1.0000	1.0000	1.0000	1.0000	1.0000	1.0000	1.0000	1.0000
Heavy Vehicles Percentage [%]	2.00	0.60	2.00	2.00	1.90	0.40	2.00	2.00	2.00	4.20	0.00	4.00
Proportion of CAVs [%]	0.00											
Growth Factor	1.0000	1.0000	1.0000	1.0000	1.0000	1.0000	1.0000	1.0000	1.0000	1.0000	1.0000	1.0000
In-Process Volume [veh/h]	0	0	0	0	0	0	0	0	0	0	0	0
Site-Generated Trips [veh/h]	0	0	0	0	0	0	0	0	0	0	0	0
Diverted Trips [veh/h]	0	0	0	0	0	0	0	0	0	0	0	0
Pass-by Trips [veh/h]	0	0	0	0	0	0	0	0	0	0	0	0
Existing Site Adjustment Volume [veh/h]	0	0	0	0	0	0	0	0	0	0	0	0
Other Volume [veh/h]	0	0	0	0	0	0	0	0	0	0	0	0
Right Turn on Red Volume [veh/h]	0	0	0	0	0	0	0	0	0	0	0	0
Total Hourly Volume [veh/h]	0	536	0	0	697	687	0	0	0	218	7	471
Peak Hour Factor	1.0000	0.9500	1.0000	1.0000	0.9500	0.9500	1.0000	1.0000	1.0000	0.9500	0.9500	0.9500
Other Adjustment Factor	1.0000	1.0000	1.0000	1.0000	1.0000	1.0000	1.0000	1.0000	1.0000	1.0000	1.0000	1.0000
Total 15-Minute Volume [veh/h]	0	141	0	0	183	181	0	0	0	57	2	124
Total Analysis Volume [veh/h]	0	564	0	0	734	723	0	0	0	229	7	496
Presence of On-Street Parking	No		No	No		No				No		No
On-Street Parking Maneuver Rate [/h]	0	0	0	0	0	0	0	0	0	0	0	0
Local Bus Stopping Rate [/h]	0	0	0	0	0	0	0	0	0	0	0	0
v_do, Outbound Pedestrian Volume crossing	0			0			0			0		
v_di, Inbound Pedestrian Volume crossing m	0			0			0			0		
v_co, Outbound Pedestrian Volume crossing	0			0			0			0		
v_ci, Inbound Pedestrian Volume crossing mi	0			0			0			0		
v_ab, Corner Pedestrian Volume [ped/h]	0			0			0			0		
Bicycle Volume [bicycles/h]	0			0			0			0		



**Intersection Settings**

Located in CBD	No
Signal Coordination Group	-
Cycle Length [s]	90
Active Pattern	Free Running (No Pattern)
Coordination Type	<i>Free Running</i>
Actuation Type	<i>Fully actuated</i>
Offset [s]	0.0
Offset Reference	Lead Green - Beginning of First Green
Permissive Mode	SingleBand
Lost time [s]	9.00

**Phasing & Timing (Basic)**

Control Type	Permiss	Permiss	Permiss	Permiss	Permiss	Permiss	Permiss	Permiss	Permiss	Permiss	Permiss	Overlap
Signal Group	0	2	0	0	6	0	0	0	0	0	8	1
Auxiliary Signal Groups												1,8
Maximum Green [s]	0	35	0	0	35	0	0	0	0	0	20	15
Amber [s]	0.0	4.8	0.0	0.0	4.8	0.0	0.0	0.0	0.0	0.0	3.7	3.7
All red [s]	0.0	0.5	0.0	0.0	0.5	0.0	0.0	0.0	0.0	0.0	0.5	0.5
Walk [s]	0	0	0	0	0	0	0	0	0	0	0	0
Pedestrian Clearance [s]	0	0	0	0	0	0	0	0	0	0	0	0
Delayed Vehicle Green [s]	0.0	0.0	0.0	0.0	0.0	0.0	0.0	0.0	0.0	0.0	0.0	0.0
Rest In Walk		No			No						No	
I1, Start-Up Lost Time [s]	0.0	2.0	0.0	0.0	2.0	0.0	0.0	0.0	0.0	0.0	2.0	2.0
I2, Clearance Lost Time [s]	0.0	3.3	0.0	0.0	3.3	0.0	0.0	0.0	0.0	0.0	2.2	2.2
Detector Location [ft]	0.0	0.0	0.0	0.0	0.0	0.0	0.0	0.0	0.0	0.0	0.0	0.0
Detector Length [ft]	0.0	20.0	0.0	0.0	20.0	0.0	0.0	0.0	0.0	0.0	20.0	20.0
I, Upstream Filtering Factor	1.00	1.00	1.00	1.00	1.00	1.00	1.00	1.00	1.00	1.00	1.00	1.00

**Phasing & Timing: Free Running (No Pattern)**

Split [s]	0	0	0	0	0	0	0	0	0	0	0	0
Lead / Lag	-	-	-	-	-	-	-	-	-	-	-	-
Minimum Green [s]	0	10	0	0	10	0	0	0	0	0	5	4
Vehicle Extension [s]	0.0	0.0	0.0	0.0	0.0	0.0	0.0	0.0	0.0	0.0	0.0	0.0
Minimum Recall		Yes			Yes						No	No
Maximum Recall		No			No						No	No
Pedestrian Recall		No			No						No	No

**Exclusive Pedestrian Phase**

Pedestrian Signal Group	0
Pedestrian Walk [s]	0
Pedestrian Clearance [s]	0



**Lane Group Calculations**

Lane Group	C	C	R		L	C	R
C, Cycle Length [s]	42	42	42		42	42	42
L, Total Lost Time per Cycle [s]	5.30	5.30	5.30		4.20	4.20	4.20
l1_p, Permitted Start-Up Lost Time [s]	0.00	0.00	0.00		0.00	0.00	0.00
l2, Clearance Lost Time [s]	3.30	3.30	3.30		2.20	2.20	0.00
g_i, Effective Green Time [s]	14	25	25		7	7	19
g / C, Green / Cycle	0.33	0.60	0.60		0.17	0.17	0.44
(v / s)_i Volume / Saturation Flow Rate	0.30	0.21	0.45		0.07	0.07	0.18
s, saturation flow rate [veh/h]	1891	3563	1610		1749	1815	2768
c, Capacity [veh/h]	630	2150	971		299	310	1221
d1, Uniform Delay [s]	13.34	4.17	6.01		15.50	15.50	8.01
k, delay calibration	0.04	0.04	0.04		0.04	0.04	0.04
l, Upstream Filtering Factor	1.00	1.00	1.00		1.00	1.00	1.00
d2, Incremental Delay [s]	1.88	0.03	0.43		0.30	0.29	0.08
d3, Initial Queue Delay [s]	0.00	0.00	0.00		0.00	0.00	0.00
Rp, platoon ratio	1.00	1.00	1.00		1.00	1.00	1.00
PF, progression factor	1.00	1.00	1.00		1.00	1.00	1.00

**Lane Group Results**

X, volume / capacity	0.90	0.34	0.74		0.39	0.39	0.41
d, Delay for Lane Group [s/veh]	15.22	4.21	6.44		15.80	15.79	8.09
Lane Group LOS	B	A	A		B	B	A
Critical Lane Group	No	No	Yes		No	No	Yes
50th-Percentile Queue Length [veh/ln]	3.72	0.61	1.81		0.84	0.87	1.04
50th-Percentile Queue Length [ft/ln]	92.98	15.21	45.34		21.00	21.74	26.10
95th-Percentile Queue Length [veh/ln]	6.69	1.09	3.26		1.51	1.57	1.88
95th-Percentile Queue Length [ft/ln]	167.37	27.37	81.61		37.79	39.13	46.98



**Movement, Approach, & Intersection Results**

d_M, Delay for Movement [s/veh]	0.00	15.22	0.00	0.00	4.21	6.44	0.00	0.00	0.00	15.80	15.79	8.09
Movement LOS		B			A	A				B	B	A
d_A, Approach Delay [s/veh]	15.22		5.31			0.00			10.58			
Approach LOS	B		A			A			B			
d_I, Intersection Delay [s/veh]	8.74											
Intersection LOS	A											
Intersection V/C	0.750											

**Emissions**

Vehicle Miles Traveled [mph]	58.78	111.67	110.00	16.81	17.42	71.95
Stops [stops/h]	318.80	104.27	155.45	71.99	74.53	178.98
Fuel consumption [US gal/h]	7.73	5.65	6.42	1.55	1.61	4.91
CO [g/h]	540.01	395.13	448.42	108.69	112.59	342.90
NOx [g/h]	105.07	76.88	87.25	21.15	21.91	66.72
VOC [g/h]	125.15	91.58	103.93	25.19	26.09	79.47

**Other Modes**

g_Walk,mi, Effective Walk Time [s]	0.0	0.0	0.0	0.0
M_corner, Corner Circulation Area [ft <sup>2</sup> /ped]	0.00	0.00	0.00	0.00
M_CW, Crosswalk Circulation Area [ft <sup>2</sup> /ped]	0.00	0.00	0.00	0.00
d_p, Pedestrian Delay [s]	0.00	0.00	0.00	0.00
I_p,int, Pedestrian LOS Score for Intersectio	0.000	0.000	0.000	0.000
Crosswalk LOS	F	F	F	F
s_b, Saturation Flow Rate of the bicycle lane	2000	2000	2000	2000
c_b, Capacity of the bicycle lane [bicycles/h]	1667	1667	0	952
d_b, Bicycle Delay [s]	0.58	0.58	21.00	5.76
I_b,int, Bicycle LOS Score for Intersection	2.490	2.762	4.132	2.767
Bicycle LOS	B	C	D	C

**Sequence**

Ring 1	1	2	-	-	-	-	-	-	-	-	-	-	-	-	-
Ring 2	-	6	-	8	-	-	-	-	-	-	-	-	-	-	-
Ring 3	-	-	-	-	-	-	-	-	-	-	-	-	-	-	-
Ring 4	-	-	-	-	-	-	-	-	-	-	-	-	-	-	-



**Intersection Level Of Service Report**  
**Intersection 12: El Charro Road & I-580 EB Ramps**

Control Type:	Signalized	Delay (sec / veh):	6.8
Analysis Method:	HCM 7th Edition	Level Of Service:	A
Analysis Period:	15 minutes	Volume to Capacity (v/c):	0.434

**Intersection Setup**

Name	El Charro Road			Fallon Road			I-580 EB Off-Ramp			I-580 EB On-Ramp		
Approach	Northbound			Southbound			Eastbound			Westbound		
Lane Configuration	↑↑			↑↑			↵↵↵↵					
Turning Movement	Left	Thru	Right	Left	Thru	Right	Left	Thru	Right	Left	Thru	Right
Lane Width [ft]	12.00	12.00	12.00	12.00	12.00	12.00	12.00	12.00	12.00	12.00	12.00	12.00
No. of Lanes in Entry Pocket	0	0	0	1	0	0	1	0	1	0	0	0
Entry Pocket Length [ft]	100.00	100.00	100.00	135.00	100.00	100.00	350.00	100.00	350.00	100.00	100.00	100.00
No. of Lanes in Exit Pocket	0	0	0	0	0	1	0	0	0	0	0	0
Exit Pocket Length [ft]	0.00	0.00	0.00	0.00	0.00	100.00	0.00	0.00	0.00	0.00	0.00	0.00
Speed [mph]	30.00			40.00			35.00			30.00		
Grade [%]	0.00			0.00			0.00			0.00		
Curb Present	No			No			No					
Crosswalk	No			No			No			Yes		



**Volumes**

Name	El Charro Road			Fallon Road			I-580 EB Off-Ramp			I-580 EB On-Ramp		
Base Volume Input [veh/h]	0	489	0	0	485	0	327	0	282	0	0	0
Base Volume Adjustment Factor	1.0000	1.0000	1.0000	1.0000	1.0000	1.0000	1.0000	1.0000	1.0000	1.0000	1.0000	1.0000
Heavy Vehicles Percentage [%]	2.00	10.40	2.00	2.00	2.70	2.00	0.90	2.00	10.60	2.00	2.00	2.00
Proportion of CAVs [%]	0.00											
Growth Factor	1.0000	1.0000	1.0000	1.0000	1.0000	1.0000	1.0000	1.0000	1.0000	1.0000	1.0000	1.0000
In-Process Volume [veh/h]	0	0	0	0	0	0	0	0	0	0	0	0
Site-Generated Trips [veh/h]	0	0	0	0	0	0	0	0	0	0	0	0
Diverted Trips [veh/h]	0	0	0	0	0	0	0	0	0	0	0	0
Pass-by Trips [veh/h]	0	0	0	0	0	0	0	0	0	0	0	0
Existing Site Adjustment Volume [veh/h]	0	0	0	0	0	0	0	0	0	0	0	0
Other Volume [veh/h]	0	0	0	0	0	0	0	0	0	0	0	0
Right Turn on Red Volume [veh/h]	0	0	0	0	0	0	0	0	0	0	0	0
Total Hourly Volume [veh/h]	0	489	0	0	485	0	327	0	282	0	0	0
Peak Hour Factor	1.0000	0.9300	1.0000	1.0000	0.9300	1.0000	0.9300	1.0000	0.9300	1.0000	1.0000	1.0000
Other Adjustment Factor	1.0000	1.0000	1.0000	1.0000	1.0000	1.0000	1.0000	1.0000	1.0000	1.0000	1.0000	1.0000
Total 15-Minute Volume [veh/h]	0	131	0	0	130	0	88	0	76	0	0	0
Total Analysis Volume [veh/h]	0	526	0	0	522	0	352	0	303	0	0	0
Presence of On-Street Parking	No		No	No		No	No		No			
On-Street Parking Maneuver Rate [/h]	0	0	0	0	0	0	0	0	0	0	0	0
Local Bus Stopping Rate [/h]	0	0	0	0	0	0	0	0	0	0	0	0
v_do, Outbound Pedestrian Volume crossing	0			0			0			0		
v_di, Inbound Pedestrian Volume crossing m	0			0			0			0		
v_co, Outbound Pedestrian Volume crossing	0			0			0			0		
v_ci, Inbound Pedestrian Volume crossing mi	0			0			0			0		
v_ab, Corner Pedestrian Volume [ped/h]	0			0			0			0		
Bicycle Volume [bicycles/h]	0			0			0			0		



**Intersection Settings**

Located in CBD	No
Signal Coordination Group	-
Cycle Length [s]	90
Active Pattern	Free Running (No Pattern)
Coordination Type	<i>Free Running</i>
Actuation Type	<i>Fully actuated</i>
Offset [s]	0.0
Offset Reference	Lead Green - Beginning of First Green
Permissive Mode	SingleBand
Lost time [s]	9.00

**Phasing & Timing (Basic)**

Control Type	Permiss	Permiss	Permiss	Permiss	Permiss	Permiss	Permiss	Permiss	Permiss	Permiss	Permiss	Permiss
Signal Group	0	2	0	0	6	0	4	0	0	0	0	0
Auxiliary Signal Groups												
Maximum Green [s]	0	40	0	0	40	0	26	0	0	0	0	0
Amber [s]	0.0	4.8	0.0	0.0	4.8	0.0	3.7	0.0	0.0	0.0	0.0	0.0
All red [s]	0.0	1.0	0.0	0.0	1.0	0.0	0.5	0.0	0.0	0.0	0.0	0.0
Walk [s]	0	0	0	0	0	0	0	0	0	0	0	0
Pedestrian Clearance [s]	0	0	0	0	0	0	0	0	0	0	0	0
Delayed Vehicle Green [s]	0.0	0.0	0.0	0.0	0.0	0.0	0.0	0.0	0.0	0.0	0.0	0.0
Rest In Walk		No			No		No					
I1, Start-Up Lost Time [s]	0.0	2.0	0.0	0.0	2.0	0.0	2.0	0.0	0.0	0.0	0.0	0.0
I2, Clearance Lost Time [s]	0.0	3.3	0.0	0.0	3.3	0.0	2.7	0.0	0.0	0.0	0.0	0.0
Detector Location [ft]	0.0	0.0	0.0	0.0	0.0	0.0	0.0	0.0	0.0	0.0	0.0	0.0
Detector Length [ft]	0.0	20.0	0.0	0.0	20.0	0.0	20.0	0.0	0.0	0.0	0.0	0.0
I, Upstream Filtering Factor	1.00	1.00	1.00	1.00	1.00	1.00	1.00	1.00	1.00	1.00	1.00	1.00

**Phasing & Timing: Free Running (No Pattern)**

Split [s]	0	0	0	0	0	0	0	0	0	0	0	0
Lead / Lag	-	-	-	-	-	-	Lead	-	-	-	-	-
Minimum Green [s]	0	10	0	0	10	0	4	0	0	0	0	0
Vehicle Extension [s]	0.0	0.0	0.0	0.0	0.0	0.0	0.0	0.0	0.0	0.0	0.0	0.0
Minimum Recall		Yes			Yes		No					
Maximum Recall		No			No		No					
Pedestrian Recall		No			No		No					

**Exclusive Pedestrian Phase**

Pedestrian Signal Group	0
Pedestrian Walk [s]	0
Pedestrian Clearance [s]	0



**Lane Group Calculations**

Lane Group	C	C	L	R	
C, Cycle Length [s]	24	24	24	24	
L, Total Lost Time per Cycle [s]	5.30	5.30	4.70	4.70	
l1_p, Permitted Start-Up Lost Time [s]	0.00	0.00	0.00	0.00	
l2, Clearance Lost Time [s]	3.30	3.30	2.70	2.70	
g_i, Effective Green Time [s]	10	10	4	4	
g / C, Green / Cycle	0.42	0.42	0.17	0.17	
(v / s)_i Volume / Saturation Flow Rate	0.16	0.15	0.10	0.12	
s, saturation flow rate [veh/h]	3320	3540	3489	2619	
c, Capacity [veh/h]	1394	1486	604	454	
d1, Uniform Delay [s]	4.91	4.85	9.34	9.50	
k, delay calibration	0.04	0.04	0.04	0.04	
l, Upstream Filtering Factor	1.00	1.00	1.00	1.00	
d2, Incremental Delay [s]	0.06	0.05	0.33	0.64	
d3, Initial Queue Delay [s]	0.00	0.00	0.00	0.00	
Rp, platoon ratio	1.00	1.00	1.00	1.00	
PF, progression factor	1.00	1.00	1.00	1.00	

**Lane Group Results**

X, volume / capacity	0.38	0.35	0.58	0.67	
d, Delay for Lane Group [s/veh]	4.98	4.90	9.67	10.13	
Lane Group LOS	A	A	A	B	
Critical Lane Group	Yes	No	No	Yes	
50th-Percentile Queue Length [veh/ln]	0.34	0.20	0.52	0.47	
50th-Percentile Queue Length [ft/ln]	8.58	4.90	13.03	11.79	
95th-Percentile Queue Length [veh/ln]	0.62	0.35	0.94	0.85	
95th-Percentile Queue Length [ft/ln]	15.44	8.83	23.45	21.23	

**Movement, Approach, & Intersection Results**

d_M, Delay for Movement [s/veh]	0.00	4.98	0.00	0.00	4.90	0.00	9.67	0.00	10.13	0.00	0.00	0.00
Movement LOS		A			A		A		B			
d_A, Approach Delay [s/veh]	4.98				4.90		9.89		0.00			
Approach LOS	A				A		A		A			
d_I, Intersection Delay [s/veh]	6.84											
Intersection LOS	A											
Intersection V/C	0.434											

**Emissions**

Vehicle Miles Traveled [mph]	90.55	51.27	40.90	35.21
Stops [stops/h]	100.95	57.72	153.36	138.83
Fuel consumption [US gal/h]	4.82	2.92	3.41	3.01
CO [g/h]	336.79	204.41	238.03	210.47
NOx [g/h]	65.53	39.77	46.31	40.95
VOC [g/h]	78.05	47.37	55.17	48.78

**Other Modes**

g_Walk,mi, Effective Walk Time [s]	0.0	0.0	0.0	-5.8
M_corner, Corner Circulation Area [ft <sup>2</sup> /ped]	0.00	0.00	0.00	0.00
M_CW, Crosswalk Circulation Area [ft <sup>2</sup> /ped]	0.00	0.00	0.00	0.00
d_p, Pedestrian Delay [s]	0.00	0.00	0.00	18.72
I_p,int, Pedestrian LOS Score for Intersectio	0.000	0.000	0.000	1.690
Crosswalk LOS	F	F	F	A
s_b, Saturation Flow Rate of the bicycle lane	2000	2000	2000	2000
c_b, Capacity of the bicycle lane [bicycles/h]	3270	3270	2125	0
d_b, Bicycle Delay [s]	4.93	4.93	0.05	12.23
I_b,int, Bicycle LOS Score for Intersection	1.994	1.990	1.560	4.132
Bicycle LOS	A	A	A	D

**Sequence**

Ring 1	-	2	-	4	-	-	-	-	-	-	-	-	-	-	-
Ring 2	-	6	-	-	-	-	-	-	-	-	-	-	-	-	-
Ring 3	-	-	-	-	-	-	-	-	-	-	-	-	-	-	-
Ring 4	-	-	-	-	-	-	-	-	-	-	-	-	-	-	-



**Intersection Level Of Service Report**  
**Intersection 13: El Charro Road & Jack London Boulevard**

Control Type:	Signalized	Delay (sec / veh):	13.8
Analysis Method:	HCM 7th Edition	Level Of Service:	B
Analysis Period:	15 minutes	Volume to Capacity (v/c):	0.417

**Intersection Setup**

Name	El Charro Road			El Charro Road			Stoneridge Drive			Jack London Boulevard		
Approach	Northbound			Southbound			Eastbound			Westbound		
Lane Configuration	TUT			TUT			TUT			TUT		
Turning Movement	Left	Thru	Right	Left	Thru	Right	Left	Thru	Right	Left	Thru	Right
Lane Width [ft]	12.00	12.00	12.00	12.00	12.00	12.00	12.00	12.00	12.00	12.00	12.00	12.00
No. of Lanes in Entry Pocket	1	0	2	2	0	1	3	0	1	1	0	2
Entry Pocket Length [ft]	125.00	100.00	175.00	650.00	100.00	450.00	450.00	100.00	325.00	400.00	100.00	775.00
No. of Lanes in Exit Pocket	0	0	0	0	0	1	1	0	0	0	0	0
Exit Pocket Length [ft]	0.00	0.00	0.00	0.00	0.00	49.21	450.00	0.00	0.00	0.00	0.00	0.00
Speed [mph]	30.00			30.00			30.00			30.00		
Grade [%]	0.00			0.00			0.00			0.00		
Curb Present	Yes			Yes			Yes			Yes		
Crosswalk	Yes			No			Yes			Yes		



**Volumes**

Name	El Charro Road			El Charro Road			Stoneridge Drive			Jack London Boulevard		
Base Volume Input [veh/h]	25	141	8	239	85	465	192	76	8	31	383	360
Base Volume Adjustment Factor	1.0000	1.0000	1.0000	1.0000	1.0000	1.0000	1.0000	1.0000	1.0000	1.0000	1.0000	1.0000
Heavy Vehicles Percentage [%]	0.00	86.00	33.30	0.40	66.70	0.20	2.30	5.30	0.00	37.50	1.20	1.10
Proportion of CAVs [%]	0.00											
Growth Factor	1.0000	1.0000	1.0000	1.0000	1.0000	1.0000	1.0000	1.0000	1.0000	1.0000	1.0000	1.0000
In-Process Volume [veh/h]	0	0	0	0	0	0	0	0	0	0	0	0
Site-Generated Trips [veh/h]	0	0	0	0	0	0	0	0	0	0	0	0
Diverted Trips [veh/h]	0	0	0	0	0	0	0	0	0	0	0	0
Pass-by Trips [veh/h]	0	0	0	0	0	0	0	0	0	0	0	0
Existing Site Adjustment Volume [veh/h]	0	0	0	0	0	0	0	0	0	0	0	0
Other Volume [veh/h]	0	0	0	0	0	0	0	0	0	0	0	0
Right Turn on Red Volume [veh/h]	0	0	0	0	0	0	0	0	0	0	0	0
Total Hourly Volume [veh/h]	25	141	8	239	85	465	192	76	8	31	383	360
Peak Hour Factor	0.8900	0.8900	0.8900	0.8900	0.8900	0.8900	0.8900	0.8900	0.8900	0.8900	0.8900	0.8900
Other Adjustment Factor	1.0000	1.0000	1.0000	1.0000	1.0000	1.0000	1.0000	1.0000	1.0000	1.0000	1.0000	1.0000
Total 15-Minute Volume [veh/h]	7	40	2	67	24	131	54	21	2	9	108	101
Total Analysis Volume [veh/h]	28	158	9	269	96	522	216	85	9	35	430	404
Presence of On-Street Parking	No		No	No		No	No		No	No		No
On-Street Parking Maneuver Rate [/h]	0	0	0	0	0	0	0	0	0	0	0	0
Local Bus Stopping Rate [/h]	0	0	0	0	0	0	0	0	0	0	0	0
v_do, Outbound Pedestrian Volume crossing	0			0			0			0		
v_di, Inbound Pedestrian Volume crossing m	0			0			0			0		
v_co, Outbound Pedestrian Volume crossing	0			0			0			1		
v_ci, Inbound Pedestrian Volume crossing mi	1			0			0			0		
v_ab, Corner Pedestrian Volume [ped/h]	0			0			0			0		
Bicycle Volume [bicycles/h]	0			0			1			0		





**Intersection Settings**

Located in CBD	No
Signal Coordination Group	-
Cycle Length [s]	90
Active Pattern	Free Running (No Pattern)
Coordination Type	<i>Free Running</i>
Actuation Type	<i>Fully actuated</i>
Offset [s]	0.0
Offset Reference	Lead Green - Beginning of First Green
Permissive Mode	SingleBand
Lost time [s]	12.00

**Phasing & Timing (Basic)**

Control Type	Protecte	Permiss	Permiss	Protecte	Permiss	Unsigna	Protecte	Permiss	Permiss	Protecte	Permiss	Overlap
Signal Group	7	4	0	3	8	0	1	6	0	5	2	2
Auxiliary Signal Groups												2,3
Maximum Green [s]	13	25	0	35	20	0	20	25	0	15	20	20
Amber [s]	3.0	5.0	0.0	3.0	4.3	0.0	3.0	4.3	0.0	3.0	4.3	4.3
All red [s]	1.0	1.0	0.0	1.0	1.0	0.0	1.0	1.0	0.0	1.0	1.0	1.0
Walk [s]	0	5	0	0	5	0	0	5	0	0	0	0
Pedestrian Clearance [s]	0	28	0	0	28	0	0	30	0	0	0	0
Delayed Vehicle Green [s]	0.0	0.0	0.0	0.0	0.0	0.0	0.0	0.0	0.0	0.0	0.0	0.0
Rest In Walk		No			No			No			No	
I1, Start-Up Lost Time [s]	2.0	2.0	0.0	2.0	2.0	0.0	2.0	2.0	0.0	2.0	2.0	2.0
I2, Clearance Lost Time [s]	2.0	2.0	0.0	2.0	2.0	0.0	2.0	2.0	0.0	2.0	2.0	2.0
Detector Location [ft]	0.0	0.0	0.0	0.0	0.0	0.0	0.0	0.0	0.0	0.0	0.0	0.0
Detector Length [ft]	20.0	20.0	0.0	20.0	20.0	0.0	20.0	20.0	0.0	0.0	0.0	0.0
I, Upstream Filtering Factor	1.00	1.00	1.00	1.00	1.00	1.00	1.00	1.00	1.00	1.00	1.00	1.00

**Phasing & Timing: Free Running (No Pattern)**

Split [s]	0	0	0	0	0	0	0	0	0	0	0	0
Lead / Lag	Lead	-	-	Lead	-	-	Lead	-	-	Lead	-	-
Minimum Green [s]	4	5	0	7	5	0	5	4	0	4	7	7
Vehicle Extension [s]	2.0	2.5	0.0	2.5	2.5	0.0	2.0	3.0	0.0	2.0	3.0	3.0
Minimum Recall	No	No		No	No		No	Yes		No	Yes	Yes
Maximum Recall	No	No		No	No		No	No		No	No	No
Pedestrian Recall	No	No		No	No		No	No		No	No	No

**Exclusive Pedestrian Phase**

Pedestrian Signal Group	0
Pedestrian Walk [s]	0
Pedestrian Clearance [s]	0



**Lane Group Calculations**

Lane Group	L	C	C	L	C	L	C	R	L	C	R
C, Cycle Length [s]	47	47	47	47	47	47	47	47	47	47	47
L, Total Lost Time per Cycle [s]	4.00	4.00	4.00	4.00	4.00	4.00	4.00	4.00	4.00	4.00	4.00
l1_p, Permitted Start-Up Lost Time [s]	0.00	0.00	0.00	0.00	0.00	0.00	0.00	0.00	0.00	0.00	0.00
l2, Clearance Lost Time [s]	2.00	2.00	2.00	2.00	2.00	2.00	2.00	2.00	2.00	2.00	0.00
g_i, Effective Green Time [s]	1	8	8	8	15	5	13	13	1	10	22
g / C, Green / Cycle	0.03	0.17	0.17	0.17	0.31	0.10	0.29	0.29	0.03	0.22	0.47
(v / s)_i Volume / Saturation Flow Rate	0.02	0.09	0.10	0.05	0.11	0.04	0.02	0.01	0.03	0.12	0.14
s, saturation flow rate [veh/h]	1810	1160	593	5254	899	5175	3466	1581	1273	3583	2834
c, Capacity [veh/h]	48	198	101	883	281	521	996	454	40	783	1337
d1, Uniform Delay [s]	22.54	17.77	17.81	17.08	12.39	19.76	12.19	11.95	22.57	16.25	7.62
k, delay calibration	0.04	0.08	0.08	0.08	0.08	0.04	0.11	0.11	0.04	0.11	0.11
l, Upstream Filtering Factor	1.00	1.00	1.00	1.00	1.00	1.00	1.00	1.00	1.00	1.00	1.00
d2, Incremental Delay [s]	4.12	1.78	3.63	0.14	0.53	0.20	0.04	0.02	17.71	0.60	0.13
d3, Initial Queue Delay [s]	0.00	0.00	0.00	0.00	0.00	0.00	0.00	0.00	0.00	0.00	0.00
Rp, platoon ratio	1.00	1.00	1.00	1.00	1.00	1.00	1.00	1.00	1.00	1.00	1.00
PF, progression factor	1.00	1.00	1.00	1.00	1.00	1.00	1.00	1.00	1.00	1.00	1.00

**Lane Group Results**

X, volume / capacity	0.58	0.55	0.56	0.30	0.34	0.41	0.09	0.02	0.87	0.55	0.30
d, Delay for Lane Group [s/veh]	26.65	19.55	21.43	17.23	12.92	19.96	12.22	11.97	40.28	16.85	7.74
Lane Group LOS	C	B	C	B	B	B	B	B	D	B	A
Critical Lane Group	No	No	Yes	Yes	No	Yes	No	No	No	Yes	No
50th-Percentile Queue Length [veh/ln]	0.33	0.53	0.60	0.76	0.69	0.67	0.28	0.06	0.55	1.84	0.96
50th-Percentile Queue Length [ft/ln]	8.30	13.16	15.03	18.98	17.27	16.72	7.05	1.49	13.68	45.96	23.96
95th-Percentile Queue Length [veh/ln]	0.60	0.95	1.08	1.37	1.24	1.20	0.51	0.11	0.99	3.31	1.73
95th-Percentile Queue Length [ft/ln]	14.94	23.69	27.05	34.17	31.09	30.10	12.69	2.69	24.63	82.72	43.14



**Movement, Approach, & Intersection Results**

d_M, Delay for Movement [s/veh]	26.65	20.13	21.43	17.23	12.92	0.00	19.96	12.22	11.97	40.28	16.85	7.74
Movement LOS	C	C	C	B	B		B	B	B	D	B	A
d_A, Approach Delay [s/veh]	21.13			7.08			17.60			13.56		
Approach LOS	C			A			B			B		
d_I, Intersection Delay [s/veh]	13.77											
Intersection LOS	B											
Intersection V/C	0.417											

**Emissions**

Vehicle Miles Traveled [mph]	1.78	6.97	3.63	46.31	16.53	23.13	9.10	0.96	6.08	74.70	70.19
Stops [stops/h]	25.60	81.17	46.34	175.64	53.26	154.74	43.49	4.60	42.20	283.46	147.82
Fuel consumption [US gal/h]	0.37	1.17	0.66	3.82	1.23	2.68	0.83	0.09	0.77	6.12	4.34
CO [g/h]	25.62	81.92	45.81	267.01	85.77	187.63	57.77	6.08	53.85	427.54	303.55
NOx [g/h]	4.98	15.94	8.91	51.95	16.69	36.51	11.24	1.18	10.48	83.18	59.06
VOC [g/h]	5.94	18.99	10.62	61.88	19.88	43.49	13.39	1.41	12.48	99.09	70.35

**Other Modes**

g_Walk,mi, Effective Walk Time [s]	9.0		0.0		9.0		9.0	
M_corner, Corner Circulation Area [ft <sup>2</sup> /ped]	0.00		0.00		0.00		0.00	
M_CW, Crosswalk Circulation Area [ft <sup>2</sup> /ped]	0.00		0.00		0.00		0.00	
d_p, Pedestrian Delay [s]	15.21		0.00		15.21		15.21	
I_p,int, Pedestrian LOS Score for Intersectio	2.332		0.000		2.899		2.842	
Crosswalk LOS	B		F		C		C	
s_b, Saturation Flow Rate of the bicycle lane	2000		2000		2000		2000	
c_b, Capacity of the bicycle lane [bicycles/h]	1071		857		1071		857	
d_b, Bicycle Delay [s]	5.04		7.63		5.04		7.63	
I_b,int, Bicycle LOS Score for Intersection	1.667		2.162		1.815		2.277	
Bicycle LOS	A		B		A		B	

**Sequence**

Ring 1	1	2	3	4	-	-	-	-	-	-	-	-	-	-	-
Ring 2	5	6	7	8	-	-	-	-	-	-	-	-	-	-	-
Ring 3	-	-	-	-	-	-	-	-	-	-	-	-	-	-	-
Ring 4	-	-	-	-	-	-	-	-	-	-	-	-	-	-	-

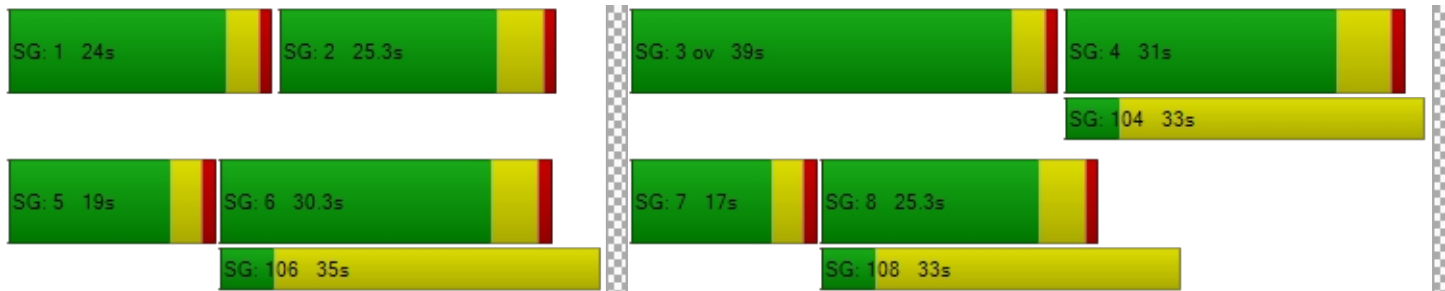

**Intersection Level Of Service Report**  
**Intersection 14: Central Parkway & Sunset View Drive**

Control Type:	Signalized	Delay (sec / veh):	31.6
Analysis Method:	HCM 7th Edition	Level Of Service:	C
Analysis Period:	15 minutes	Volume to Capacity (v/c):	0.764

**Intersection Setup**

Name	Driveway			Sunset View Drive			Central Parkway			Central Parkway		
Approach	Northbound			Southbound			Eastbound			Westbound		
Lane Configuration	↵↵			↵↵			↵↵↵			↵↵		
Turning Movement	Left	Thru	Right	Left	Thru	Right	Left	Thru	Right	Left	Thru	Right
Lane Width [ft]	12.00	12.00	12.00	12.00	12.00	12.00	12.00	12.00	12.00	12.00	12.00	12.00
No. of Lanes in Entry Pocket	1	0	0	0	0	1	1	0	1	1	0	0
Entry Pocket Length [ft]	250.00	100.00	100.00	100.00	100.00	85.00	225.00	100.00	800.00	150.00	100.00	100.00
No. of Lanes in Exit Pocket	0	0	0	0	0	0	0	0	0	0	0	0
Exit Pocket Length [ft]	0.00	0.00	0.00	0.00	0.00	0.00	0.00	0.00	0.00	0.00	0.00	0.00
Speed [mph]	30.00			30.00			30.00			30.00		
Grade [%]	0.00			0.00			0.00			0.00		
Curb Present	No			No			No			No		
Crosswalk	Yes			Yes			Yes			Yes		



**Volumes**

Name	Driveway			Sunset View Drive			Central Parkway			Central Parkway		
Base Volume Input [veh/h]	150	18	8	17	16	149	40	173	168	17	232	2
Base Volume Adjustment Factor	1.0000	1.0000	1.0000	1.0000	1.0000	1.0000	1.0000	1.0000	1.0000	1.0000	1.0000	1.0000
Heavy Vehicles Percentage [%]	0.70	0.00	0.00	0.00	0.00	2.00	2.50	1.70	0.00	0.00	0.40	0.00
Proportion of CAVs [%]	0.00											
Growth Factor	1.0000	1.0000	1.0000	1.0000	1.0000	1.0000	1.0000	1.0000	1.0000	1.0000	1.0000	1.0000
In-Process Volume [veh/h]	0	0	0	0	0	0	0	0	0	0	0	0
Site-Generated Trips [veh/h]	0	0	0	0	0	0	0	0	0	0	0	0
Diverted Trips [veh/h]	0	0	0	0	0	0	0	0	0	0	0	0
Pass-by Trips [veh/h]	0	0	0	0	0	0	0	0	0	0	0	0
Existing Site Adjustment Volume [veh/h]	0	0	0	0	0	0	0	0	0	0	0	0
Other Volume [veh/h]	0	0	0	0	0	0	0	0	0	0	0	0
Right Turn on Red Volume [veh/h]	0	0	0	0	0	0	0	0	0	0	0	0
Total Hourly Volume [veh/h]	150	18	8	17	16	149	40	173	168	17	232	2
Peak Hour Factor	0.5500	0.5500	0.5500	0.5500	0.5500	0.5500	0.5500	0.5500	0.5500	0.5500	0.5500	0.5500
Other Adjustment Factor	1.0000	1.0000	1.0000	1.0000	1.0000	1.0000	1.0000	1.0000	1.0000	1.0000	1.0000	1.0000
Total 15-Minute Volume [veh/h]	68	8	4	8	7	68	18	79	76	8	105	1
Total Analysis Volume [veh/h]	273	33	15	31	29	271	73	315	305	31	422	4
Presence of On-Street Parking	No		No	No		No	No		No	No		No
On-Street Parking Maneuver Rate [/h]	0	0	0	0	0	0	0	0	0	0	0	0
Local Bus Stopping Rate [/h]	0	0	0	0	0	0	0	0	0	0	0	0
v_do, Outbound Pedestrian Volume crossing	74			14			74			14		
v_di, Inbound Pedestrian Volume crossing m	74			14			74			14		
v_co, Outbound Pedestrian Volume crossing	123			37			37			124		
v_ci, Inbound Pedestrian Volume crossing mi	124			37			37			123		
v_ab, Corner Pedestrian Volume [ped/h]	0			0			0			0		
Bicycle Volume [bicycles/h]	2			0			11			0		



**Intersection Settings**

Located in CBD	No
Signal Coordination Group	-
Cycle Length [s]	90
Active Pattern	Free Running (No Pattern)
Coordination Type	<i>Free Running</i>
Actuation Type	<i>Fully actuated</i>
Offset [s]	0.0
Offset Reference	Lead Green - Beginning of First Green
Permissive Mode	SingleBand
Lost time [s]	12.00

**Phasing & Timing (Basic)**

Control Type	Protecte	Permiss	Permiss	Protecte	Permiss	Permiss	Protecte	Permiss	Permiss	Protecte	Permiss	Permiss
Signal Group	3	8	0	7	4	0	5	2	0	1	6	0
Auxiliary Signal Groups												
Maximum Green [s]	30	30	0	20	20	0	20	25	0	20	25	0
Amber [s]	3.0	3.0	0.0	3.0	3.0	0.0	3.0	3.6	0.0	3.0	3.6	0.0
All red [s]	1.0	1.0	0.0	1.0	1.0	0.0	1.0	1.0	0.0	1.0	1.0	0.0
Walk [s]	0	4	0	0	4	0	0	4	0	0	4	0
Pedestrian Clearance [s]	0	24	0	0	21	0	0	16	0	0	17	0
Delayed Vehicle Green [s]	0.0	0.0	0.0	0.0	0.0	0.0	0.0	0.0	0.0	0.0	0.0	0.0
Rest In Walk		No			No			No			No	
I1, Start-Up Lost Time [s]	2.0	2.0	0.0	2.0	2.0	0.0	2.0	2.0	0.0	2.0	2.0	0.0
I2, Clearance Lost Time [s]	2.0	2.0	0.0	2.0	2.0	0.0	2.0	2.0	0.0	2.0	2.0	0.0
Detector Location [ft]	0.0	0.0	0.0	0.0	0.0	0.0	0.0	0.0	0.0	0.0	0.0	0.0
Detector Length [ft]	20.0	20.0	0.0	20.0	20.0	0.0	20.0	20.0	0.0	20.0	20.0	0.0
I, Upstream Filtering Factor	1.00	1.00	1.00	1.00	1.00	1.00	1.00	1.00	1.00	1.00	1.00	1.00

**Phasing & Timing: Free Running (No Pattern)**

Split [s]	9	14	0	9	14	0	9	14	0	9	14	0
Lead / Lag	Lead	-	-	Lead	-	-	Lead	-	-	Lead	-	-
Minimum Green [s]	5	10	0	5	10	0	5	10	0	5	10	0
Vehicle Extension [s]	2.0	4.0	0.0	2.0	4.0	0.0	2.0	4.0	0.0	2.0	4.0	0.0
Minimum Recall	No	No		No	No		No	Yes		No	Yes	
Maximum Recall	No	No		No	No		No	No		No	No	
Pedestrian Recall	No	No		No	No		No	No		No	No	

**Exclusive Pedestrian Phase**

Pedestrian Signal Group	0
Pedestrian Walk [s]	0
Pedestrian Clearance [s]	0



**Lane Group Calculations**

Lane Group	L	C	L	C	L	C	R	L	C
C, Cycle Length [s]	73	73	73	73	73	73	73	73	73
L, Total Lost Time per Cycle [s]	4.00	4.00	4.00	4.00	4.00	4.00	4.00	4.00	4.00
l1_p, Permitted Start-Up Lost Time [s]	0.00	0.00	0.00	0.00	0.00	0.00	0.00	0.00	0.00
l2, Clearance Lost Time [s]	2.00	2.00	2.00	2.00	2.00	2.00	2.00	2.00	2.00
g_i, Effective Green Time [s]	13	31	2	20	4	22	22	2	20
g / C, Green / Cycle	0.18	0.42	0.03	0.27	0.05	0.30	0.30	0.03	0.27
(v / s)_i Volume / Saturation Flow Rate	0.15	0.03	0.02	0.21	0.04	0.17	0.26	0.02	0.23
s, saturation flow rate [veh/h]	1800	1558	1810	1433	1774	1874	1170	1810	1890
c, Capacity [veh/h]	324	655	59	391	96	554	346	59	518
d1, Uniform Delay [s]	29.01	12.67	34.86	24.46	34.16	21.82	22.38	34.86	24.90
k, delay calibration	0.04	0.15	0.04	0.29	0.04	0.15	0.30	0.04	0.23
l, Upstream Filtering Factor	1.00	1.00	1.00	1.00	1.00	1.00	1.00	1.00	1.00
d2, Incremental Delay [s]	2.31	0.07	2.70	8.12	4.59	1.31	17.35	2.70	6.84
d3, Initial Queue Delay [s]	0.00	0.00	0.00	0.00	0.00	0.00	0.00	0.00	0.00
Rp, platoon ratio	1.00	1.00	1.00	1.00	1.00	1.00	1.00	1.00	1.00
PF, progression factor	1.00	1.00	1.00	1.00	1.00	1.00	1.00	1.00	1.00

**Lane Group Results**

X, volume / capacity	0.84	0.07	0.53	0.77	0.76	0.57	0.88	0.53	0.82
d, Delay for Lane Group [s/veh]	31.33	12.74	37.56	32.57	38.74	23.13	39.73	37.56	31.74
Lane Group LOS	C	B	D	C	D	C	D	D	C
Critical Lane Group	Yes	No	No	Yes	No	No	Yes	Yes	No
50th-Percentile Queue Length [veh/ln]	4.64	0.45	0.57	5.38	1.36	4.52	5.96	0.57	7.50
50th-Percentile Queue Length [ft/ln]	115.92	11.28	14.31	134.45	34.11	113.06	148.98	14.31	187.53
95th-Percentile Queue Length [veh/ln]	8.17	0.81	1.03	9.18	2.46	8.01	9.96	1.03	11.99
95th-Percentile Queue Length [ft/ln]	204.21	20.30	25.76	229.54	61.39	200.25	249.06	25.76	299.82



**Movement, Approach, & Intersection Results**

d_M, Delay for Movement [s/veh]	31.33	12.74	12.74	37.56	32.57	32.57	38.74	23.13	39.73	37.56	31.74	31.74
Movement LOS	C	B	B	D	C	C	D	C	D	D	C	C
d_A, Approach Delay [s/veh]	28.55			33.04			32.08			32.14		
Approach LOS	C			C			C			C		
d_I, Intersection Delay [s/veh]	31.64											
Intersection LOS	C											
Intersection V/C	0.764											

**Emissions**

Vehicle Miles Traveled [mph]	7.44	1.31	1.15	11.15	16.60	71.61	69.34	6.55	90.05
Stops [stops/h]	228.56	22.23	28.21	265.10	67.24	222.92	293.74	28.21	369.74
Fuel consumption [US gal/h]	3.31	0.30	0.44	3.91	1.63	5.66	6.94	0.66	8.50
CO [g/h]	231.32	21.05	30.77	273.48	113.95	395.79	485.34	46.32	594.27
NOx [g/h]	45.01	4.10	5.99	53.21	22.17	77.01	94.43	9.01	115.62
VOC [g/h]	53.61	4.88	7.13	63.38	26.41	91.73	112.48	10.73	137.73

**Other Modes**

g_Walk,mi, Effective Walk Time [s]	8.0	8.0	8.0	8.0
M_corner, Corner Circulation Area [ft <sup>2</sup> /ped]	0.00	0.00	0.00	0.00
M_CW, Crosswalk Circulation Area [ft <sup>2</sup> /ped]	0.00	0.00	0.00	0.00
d_p, Pedestrian Delay [s]	28.95	28.95	28.95	28.95
I_p,int, Pedestrian LOS Score for Intersectio	2.155	2.076	2.528	2.198
Crosswalk LOS	B	B	B	B
s_b, Saturation Flow Rate of the bicycle lane	2000	2000	2000	2000
c_b, Capacity of the bicycle lane [bicycles/h]	822	548	685	685
d_b, Bicycle Delay [s]	12.69	19.26	15.88	15.80
I_b,int, Bicycle LOS Score for Intersection	2.089	2.106	2.703	2.314
Bicycle LOS	B	B	B	B

**Sequence**

Ring 1	1	2	3	4	-	-	-	-	-	-	-	-	-	-	-
Ring 2	5	6	7	8	-	-	-	-	-	-	-	-	-	-	-
Ring 3	-	-	-	-	-	-	-	-	-	-	-	-	-	-	-
Ring 4	-	-	-	-	-	-	-	-	-	-	-	-	-	-	-





**Intersection Level Of Service Report**

**Intersection 15: Central Parkway & Panorama Drive/Pino Grande Road**

Control Type:	All-way stop	Delay (sec / veh):	11.0
Analysis Method:	HCM 7th Edition	Level Of Service:	B
Analysis Period:	15 minutes	Volume to Capacity (v/c):	0.359

**Intersection Setup**

Name	Pino Grande Road			Panorama Drive			Central Parkway			Central Parkway		
Approach	Northbound			Southbound			Eastbound			Westbound		
Lane Configuration	+			+r			+r			+r		
Turning Movement	Left	Thru	Right	Left	Thru	Right	Left	Thru	Right	Left	Thru	Right
Lane Width [ft]	12.00	12.00	12.00	12.00	12.00	12.00	12.00	12.00	12.00	12.00	12.00	12.00
No. of Lanes in Entry Pocket	0	0	0	0	0	1	1	0	0	1	0	0
Entry Pocket Length [ft]	100.00	100.00	100.00	100.00	100.00	100.00	275.00	100.00	100.00	100.00	100.00	100.00
No. of Lanes in Exit Pocket	0	0	0	0	0	0	0	0	0	0	0	0
Exit Pocket Length [ft]	0.00	0.00	0.00	0.00	0.00	0.00	0.00	0.00	0.00	0.00	0.00	0.00
Speed [mph]	30.00			30.00			30.00			30.00		
Grade [%]	0.00			0.00			0.00			0.00		
Crosswalk	Yes			Yes			Yes			Yes		

**Volumes**

Name	Pino Grande Road			Panorama Drive			Central Parkway			Central Parkway		
Base Volume Input [veh/h]	37	2	0	1	4	127	97	84	6	0	91	2
Base Volume Adjustment Factor	1.0000	1.0000	1.0000	1.0000	1.0000	1.0000	1.0000	1.0000	1.0000	1.0000	1.0000	1.0000
Heavy Vehicles Percentage [%]	0.00	0.00	0.00	0.00	0.00	0.00	2.10	1.20	0.00	0.00	0.00	0.00
Growth Factor	1.0000	1.0000	1.0000	1.0000	1.0000	1.0000	1.0000	1.0000	1.0000	1.0000	1.0000	1.0000
In-Process Volume [veh/h]	0	0	0	0	0	0	0	0	0	0	0	0
Site-Generated Trips [veh/h]	0	0	0	0	0	0	0	0	0	0	0	0
Diverted Trips [veh/h]	0	0	0	0	0	0	0	0	0	0	0	0
Pass-by Trips [veh/h]	0	0	0	0	0	0	0	0	0	0	0	0
Existing Site Adjustment Volume [veh/h]	0	0	0	0	0	0	0	0	0	0	0	0
Other Volume [veh/h]	0	0	0	0	0	0	0	0	0	0	0	0
Total Hourly Volume [veh/h]	37	2	0	1	4	127	97	84	6	0	91	2
Peak Hour Factor	0.5300	0.5300	0.5300	0.5300	0.5300	0.5300	0.5300	0.5300	0.5300	0.5300	0.5300	0.5300
Other Adjustment Factor	1.0000	1.0000	1.0000	1.0000	1.0000	1.0000	1.0000	1.0000	1.0000	1.0000	1.0000	1.0000
Total 15-Minute Volume [veh/h]	17	1	0	0	2	60	46	40	3	0	43	1
Total Analysis Volume [veh/h]	70	4	0	2	8	240	183	158	11	0	172	4
Pedestrian Volume [ped/h]	117			1			103			89		



**Intersection Settings****Lanes**

Capacity per Entry Lane [veh/h]	549	581	669	578	636	608	610
Degree of Utilization, x	0.13	0.02	0.36	0.32	0.27	0.00	0.29

**Movement, Approach, & Intersection Results**

95th-Percentile Queue Length [veh]	0.46	0.05	1.63	1.35	1.07	0.00	1.19
95th-Percentile Queue Length [ft]	11.60	1.31	40.78	33.79	26.64	0.00	29.79
Approach Delay [s/veh]	10.58	10.99		11.11		10.99	
Approach LOS	B	B		B		B	
Intersection Delay [s/veh]	11.01						
Intersection LOS	B						

**Intersection Level Of Service Report**  
**Intersection 16: Airway Boulevard & N. Canyons Parkway**

Control Type:	Signalized	Delay (sec / veh):	17.8
Analysis Method:	HCM 7th Edition	Level Of Service:	B
Analysis Period:	15 minutes	Volume to Capacity (v/c):	0.436

**Intersection Setup**

Name	Airway Boulevard			Driveway			N. Canyons Parkway			N Canyons Parkway		
Approach	Northbound			Southbound			Eastbound			Westbound		
Lane Configuration	⇌⇌⇌			+			⇌⇌			⇌⇌⇌		
Turning Movement	Left	Thru	Right	Left	Thru	Right	Left	Thru	Right	Left	Thru	Right
Lane Width [ft]	12.00	12.00	12.00	12.00	12.00	12.00	12.00	12.00	12.00	12.00	12.00	12.00
No. of Lanes in Entry Pocket	0	0	0	0	0	0	0	0	0	1	0	1
Entry Pocket Length [ft]	100.00	100.00	100.00	100.00	100.00	100.00	100.00	100.00	100.00	110.00	100.00	195.00
No. of Lanes in Exit Pocket	0	0	0	0	0	0	0	0	0	0	0	0
Exit Pocket Length [ft]	0.00	0.00	0.00	0.00	0.00	0.00	0.00	0.00	0.00	0.00	0.00	0.00
Speed [mph]	40.00			30.00			40.00			40.00		
Grade [%]	0.00			0.00			0.00			0.00		
Curb Present	Yes			Yes			Yes			Yes		
Crosswalk	Yes			Yes			Yes			No		



**Volumes**

Name	Airway Boulevard			Driveway			N. Canyons Parkway			N Canyons Parkway		
Base Volume Input [veh/h]	288	14	469	0	4	0	0	40	77	395	298	1
Base Volume Adjustment Factor	1.0000	1.0000	1.0000	1.0000	1.0000	1.0000	1.0000	1.0000	1.0000	1.0000	1.0000	1.0000
Heavy Vehicles Percentage [%]	3.60	0.00	2.10	0.00	0.00	0.00	2.00	0.00	22.60	4.40	0.00	0.00
Proportion of CAVs [%]	0.00											
Growth Factor	1.0000	1.0000	1.0000	1.0000	1.0000	1.0000	1.0000	1.0000	1.0000	1.0000	1.0000	1.0000
In-Process Volume [veh/h]	0	0	0	0	0	0	0	0	0	0	0	0
Site-Generated Trips [veh/h]	0	0	0	0	0	0	0	0	0	0	0	0
Diverted Trips [veh/h]	0	0	0	0	0	0	0	0	0	0	0	0
Pass-by Trips [veh/h]	0	0	0	0	0	0	0	0	0	0	0	0
Existing Site Adjustment Volume [veh/h]	0	0	0	0	0	0	0	0	0	0	0	0
Other Volume [veh/h]	0	0	0	0	0	0	0	0	0	0	0	0
Right Turn on Red Volume [veh/h]	0	0	0	0	0	0	0	0	0	0	0	0
Total Hourly Volume [veh/h]	288	14	469	0	4	0	0	40	77	395	298	1
Peak Hour Factor	0.8900	0.8900	0.8900	0.8900	0.8900	0.8900	1.0000	0.8900	0.8900	0.8900	0.8900	0.8900
Other Adjustment Factor	1.0000	1.0000	1.0000	1.0000	1.0000	1.0000	1.0000	1.0000	1.0000	1.0000	1.0000	1.0000
Total 15-Minute Volume [veh/h]	81	4	132	0	1	0	0	11	22	111	84	0
Total Analysis Volume [veh/h]	324	16	527	0	4	0	0	45	87	444	335	1
Presence of On-Street Parking	No		No	No		No	No		No	No		No
On-Street Parking Maneuver Rate [/h]	0	0	0	0	0	0	0	0	0	0	0	0
Local Bus Stopping Rate [/h]	0	0	0	0	0	0	0	0	0	0	0	0
v_do, Outbound Pedestrian Volume crossing	0			0			0			0		
v_di, Inbound Pedestrian Volume crossing m	0			0			0			0		
v_co, Outbound Pedestrian Volume crossing	0			1			0			0		
v_ci, Inbound Pedestrian Volume crossing mi	0			0			0			1		
v_ab, Corner Pedestrian Volume [ped/h]	0			0			0			0		
Bicycle Volume [bicycles/h]	0			0			0			0		



**Intersection Settings**

Located in CBD	No
Signal Coordination Group	-
Cycle Length [s]	105
Active Pattern	Pattern 1
Coordination Type	Time of Day Pattern Coordinated
Actuation Type	Fully actuated
Offset [s]	0.0
Offset Reference	Lead Green - Beginning of First Green
Permissive Mode	SingleBand
Lost time [s]	12.00

**Phasing & Timing (Basic)**

Control Type	Split	Split	Overlap	Split	Split	Split	Permiss	Permiss	Permiss	Protecte	Permiss	Permiss
Signal Group	0	8	8	0	4	0	0	2	0	1	6	0
Auxiliary Signal Groups			1,8									
Maximum Green [s]	0	20	20	0	12	0	0	15	0	50	50	0
Amber [s]	0.0	3.2	3.2	0.0	3.0	0.0	0.0	5.0	0.0	5.0	5.0	0.0
All red [s]	0.0	1.0	1.0	0.0	1.0	0.0	0.0	1.0	0.0	1.0	1.0	0.0
Walk [s]	0	0	0	0	5	0	0	5	0	0	5	0
Pedestrian Clearance [s]	0	0	0	0	28	0	0	29	0	0	12	0
Delayed Vehicle Green [s]	0.0	0.0	0.0	0.0	0.0	0.0	0.0	0.0	0.0	0.0	0.0	0.0
Rest In Walk		No			No			No			No	
I1, Start-Up Lost Time [s]	0.0	2.0	2.0	0.0	2.0	0.0	0.0	2.0	0.0	2.0	2.0	0.0
I2, Clearance Lost Time [s]	0.0	2.0	2.0	0.0	2.0	0.0	0.0	2.0	0.0	2.0	2.0	0.0
Detector Location [ft]	0.0	0.0	0.0	0.0	0.0	0.0	0.0	0.0	0.0	0.0	0.0	0.0
Detector Length [ft]	0.0	20.0	20.0	0.0	20.0	0.0	0.0	20.0	0.0	20.0	20.0	0.0
I, Upstream Filtering Factor	1.00	1.00	1.00	1.00	1.00	1.00	1.00	1.00	1.00	1.00	1.00	1.00

**Phasing & Timing: Pattern 1**

Split [s]	0	25	25	0	20	0	0	30	0	30	60	0
Lead / Lag	-	-	-	-	-	-	-	-	-	Lead	-	-
Minimum Green [s]	0	4	4	0	3	0	0	10	0	3	7	0
Vehicle Extension [s]	0.0	2.0	2.0	0.0	2.0	0.0	0.0	2.0	0.0	2.0	2.0	0.0
Minimum Recall		No	No		No			No		No	Yes	
Maximum Recall		No	No		No			No		Yes	Yes	
Pedestrian Recall		No	No		No			No		No	No	

**Exclusive Pedestrian Phase**

Pedestrian Signal Group	0
Pedestrian Walk [s]	0
Pedestrian Clearance [s]	0



**Lane Group Calculations**

Lane Group	C	R	C	C	R	L	C	R
C, Cycle Length [s]	105	105	105	105	105	105	105	105
L, Total Lost Time per Cycle [s]	4.00	4.00	4.00	4.00	4.00	4.00	4.00	4.00
l1_p, Permitted Start-Up Lost Time [s]	0.00	0.00	0.00	0.00	0.00	0.00	0.00	0.00
l2, Clearance Lost Time [s]	2.00	0.00	2.00	2.00	2.00	2.00	2.00	2.00
g_i, Effective Green Time [s]	23	81	0	12	12	54	70	70
g / C, Green / Cycle	0.22	0.77	0.00	0.11	0.11	0.52	0.67	0.67
(v / s)_i Volume / Saturation Flow Rate	0.19	0.19	0.00	0.01	0.07	0.13	0.18	0.00
s, saturation flow rate [veh/h]	1814	2811	1900	3618	1327	3392	1900	1614
c, Capacity [veh/h]	391	2110	7	407	149	1751	1267	1076
d1, Uniform Delay [s]	39.80	4.02	52.26	41.90	44.28	14.14	7.08	5.83
k, delay calibration	0.04	0.50	0.04	0.04	0.04	0.50	0.50	0.50
l, Upstream Filtering Factor	1.00	1.00	1.00	1.00	1.00	1.00	1.00	1.00
d2, Incremental Delay [s]	2.39	0.28	26.31	0.04	1.35	0.35	0.51	0.00
d3, Initial Queue Delay [s]	0.00	0.00	0.00	0.00	0.00	0.00	0.00	0.00
Rp, platoon ratio	1.00	1.00	1.00	1.00	1.00	1.00	1.00	1.00
PF, progression factor	1.00	1.00	1.00	1.00	1.00	1.00	1.00	1.00

**Lane Group Results**

X, volume / capacity	0.87	0.25	0.59	0.11	0.58	0.25	0.26	0.00
d, Delay for Lane Group [s/veh]	42.18	4.30	78.56	41.94	45.63	14.49	7.59	5.84
Lane Group LOS	D	A	E	D	D	B	A	A
Critical Lane Group	Yes	No	Yes	No	Yes	Yes	No	No
50th-Percentile Queue Length [veh/ln]	8.44	1.36	0.15	0.52	2.16	2.83	2.77	0.01
50th-Percentile Queue Length [ft/ln]	211.06	33.92	3.87	12.91	53.90	70.84	69.29	0.17
95th-Percentile Queue Length [veh/ln]	13.21	2.44	0.28	0.93	3.88	5.10	4.99	0.01
95th-Percentile Queue Length [ft/ln]	330.19	61.05	6.97	23.24	97.02	127.52	124.72	0.31

**Movement, Approach, & Intersection Results**

d_M, Delay for Movement [s/veh]	42.18	42.18	4.30	78.56	78.56	78.56	0.00	41.94	45.63	14.49	7.59	5.84
Movement LOS	D	D	A	E	E	E		D	D	B	A	A
d_A, Approach Delay [s/veh]	19.16			78.56				44.37		11.51		
Approach LOS	B			E				D		B		
d_I, Intersection Delay [s/veh]	17.81											
Intersection LOS	B											
Intersection V/C	0.436											

**Emissions**

Vehicle Miles Traveled [mph]	40.37	62.58	0.14	2.93	5.67	36.31	27.40	0.08
Stops [stops/h]	289.39	93.01	5.31	35.41	73.90	194.27	95.00	0.23
Fuel consumption [US gal/h]	7.21	3.62	0.10	0.84	1.74	4.52	2.43	0.01
CO [g/h]	503.80	252.79	6.92	58.50	121.41	315.83	170.00	0.45
NOx [g/h]	98.02	49.18	1.35	11.38	23.62	61.45	33.08	0.09
VOC [g/h]	116.76	58.59	1.60	13.56	28.14	73.20	39.40	0.10

**Other Modes**

g_Walk,mi, Effective Walk Time [s]	9.0	9.0	9.0	0.0
M_corner, Corner Circulation Area [ft <sup>2</sup> /ped]	0.00	0.00	0.00	0.00
M_CW, Crosswalk Circulation Area [ft <sup>2</sup> /ped]	0.00	5853.56	0.00	0.00
d_p, Pedestrian Delay [s]	43.90	43.90	43.90	0.00
I_p,int, Pedestrian LOS Score for Intersectio	2.766	1.734	2.514	0.000
Crosswalk LOS	C	A	B	F
s_b, Saturation Flow Rate of the bicycle lane	2000	2000	2000	2000
c_b, Capacity of the bicycle lane [bicycles/h]	396	305	457	1028
d_b, Bicycle Delay [s]	33.77	37.73	31.25	12.39
I_b,int, Bicycle LOS Score for Intersection	2.990	1.566	1.669	2.847
Bicycle LOS	C	A	A	C

**Sequence**

Ring 1	1	2	4	8	-	-	-	-	-	-	-	-	-	-	-
Ring 2	-	6	-	-	-	-	-	-	-	-	-	-	-	-	-
Ring 3	-	-	-	-	-	-	-	-	-	-	-	-	-	-	-
Ring 4	-	-	-	-	-	-	-	-	-	-	-	-	-	-	-



**Intersection Level Of Service Report**  
**Intersection 17: Airway Boulevard & I-580 WB Ramps**

Control Type:	Signalized	Delay (sec / veh):	13.5
Analysis Method:	HCM 7th Edition	Level Of Service:	B
Analysis Period:	15 minutes	Volume to Capacity (v/c):	0.253

**Intersection Setup**

Name	Airway Boulevard			Airway Boulevard			I-580 WB On-Ramp			I-580 WB Off-Ramp		
Approach	Northbound			Southbound			Eastbound			Westbound		
Lane Configuration	r			r						r rr		
Turning Movement	Left	Thru	Right	Left	Thru	Right	Left	Thru	Right	Left	Thru	Right
Lane Width [ft]	12.00	12.00	12.00	12.00	12.00	12.00	12.00	12.00	12.00	12.00	12.00	12.00
No. of Lanes in Entry Pocket	0	0	0	0	0	1	0	0	0	1	0	1
Entry Pocket Length [ft]	100.00	100.00	100.00	100.00	100.00	250.00	100.00	100.00	100.00	150.00	100.00	490.00
No. of Lanes in Exit Pocket	0	0	0	0	0	0	0	0	0	0	0	0
Exit Pocket Length [ft]	0.00	0.00	0.00	0.00	0.00	0.00	0.00	0.00	0.00	0.00	0.00	0.00
Speed [mph]	40.00			40.00			30.00			45.00		
Grade [%]	0.00			0.00			0.00			0.00		
Curb Present	Yes			Yes						Yes		
Crosswalk	No			No			No			Yes		





**Volumes**

Name	Airway Boulevard			Airway Boulevard			I-580 WB On-Ramp			I-580 WB Off-Ramp		
	Base Volume Input [veh/h]	0	665	131	0	170	363	0	0	0	48	0
Base Volume Adjustment Factor	1.0000	1.0000	1.0000	1.0000	1.0000	1.0000	1.0000	1.0000	1.0000	1.0000	1.0000	1.0000
Heavy Vehicles Percentage [%]	2.00	2.90	9.20	2.00	5.70	6.80	2.00	2.00	2.00	4.20	0.00	8.50
Proportion of CAVs [%]	0.00											
Growth Factor	1.0000	1.0000	1.0000	1.0000	1.0000	1.0000	1.0000	1.0000	1.0000	1.0000	1.0000	1.0000
In-Process Volume [veh/h]	0	0	0	0	0	0	0	0	0	0	0	0
Site-Generated Trips [veh/h]	0	0	0	0	0	0	0	0	0	0	0	0
Diverted Trips [veh/h]	0	0	0	0	0	0	0	0	0	0	0	0
Pass-by Trips [veh/h]	0	0	0	0	0	0	0	0	0	0	0	0
Existing Site Adjustment Volume [veh/h]	0	0	0	0	0	0	0	0	0	0	0	0
Other Volume [veh/h]	0	0	0	0	0	0	0	0	0	0	0	0
Right Turn on Red Volume [veh/h]	0	0	0	0	0	0	0	0	0	0	0	0
Total Hourly Volume [veh/h]	0	665	131	0	170	363	0	0	0	48	0	284
Peak Hour Factor	1.0000	0.8700	0.8700	1.0000	0.8700	0.8700	1.0000	1.0000	1.0000	0.8700	0.8700	0.8700
Other Adjustment Factor	1.0000	1.0000	1.0000	1.0000	1.0000	1.0000	1.0000	1.0000	1.0000	1.0000	1.0000	1.0000
Total 15-Minute Volume [veh/h]	0	191	38	0	49	104	0	0	0	14	0	82
Total Analysis Volume [veh/h]	0	764	151	0	195	417	0	0	0	55	0	326
Presence of On-Street Parking	No		No	No		No				No		No
On-Street Parking Maneuver Rate [/h]	0	0	0	0	0	0	0	0	0	0	0	0
Local Bus Stopping Rate [/h]	0	0	0	0	0	0	0	0	0	0	0	0
v_do, Outbound Pedestrian Volume crossing	0			0			0			0		
v_di, Inbound Pedestrian Volume crossing m	0			0			0			0		
v_co, Outbound Pedestrian Volume crossing	1			0			0			1		
v_ci, Inbound Pedestrian Volume crossing mi	1			0			0			1		
v_ab, Corner Pedestrian Volume [ped/h]	0			0			0			0		
Bicycle Volume [bicycles/h]	0			0			0			0		



**Intersection Settings**

Located in CBD	No
Signal Coordination Group	-
Cycle Length [s]	105
Active Pattern	Pattern 1
Coordination Type	Time of Day Pattern Coordinated
Actuation Type	Fully actuated
Offset [s]	91.0
Offset Reference	Lead Green - Beginning of First Green
Permissive Mode	SingleBand
Lost time [s]	9.00

**Phasing & Timing (Basic)**

Control Type	Permiss	Permiss	Unsigna	Permiss	Permiss	Unsigna	Permiss	Permiss	Permiss	Permiss	Permiss	Overlap
Signal Group	0	2	0	0	6	0	0	0	0	0	8	1
Auxiliary Signal Groups												1,8
Maximum Green [s]	0	30	0	0	25	0	0	0	0	0	20	12
Amber [s]	0.0	4.3	0.0	0.0	4.3	0.0	0.0	0.0	0.0	0.0	3.0	3.0
All red [s]	0.0	1.0	0.0	0.0	1.0	0.0	0.0	0.0	0.0	0.0	1.0	0.0
Walk [s]	0	7	0	0	0	0	0	0	0	0	0	0
Pedestrian Clearance [s]	0	15	0	0	0	0	0	0	0	0	0	0
Delayed Vehicle Green [s]	0.0	0.0	0.0	0.0	0.0	0.0	0.0	0.0	0.0	0.0	0.0	0.0
Rest In Walk		No			No						No	
I1, Start-Up Lost Time [s]	0.0	2.0	0.0	0.0	2.0	0.0	0.0	0.0	0.0	0.0	2.0	2.0
I2, Clearance Lost Time [s]	0.0	2.0	0.0	0.0	2.0	0.0	0.0	0.0	0.0	0.0	2.0	2.0
Detector Location [ft]	0.0	0.0	0.0	0.0	0.0	0.0	0.0	0.0	0.0	0.0	0.0	0.0
Detector Length [ft]	0.0	20.0	0.0	0.0	20.0	0.0	0.0	0.0	0.0	0.0	20.0	20.0
I, Upstream Filtering Factor	1.00	1.00	1.00	1.00	1.00	1.00	1.00	1.00	1.00	1.00	1.00	1.00

**Phasing & Timing: Pattern 1**

Split [s]	0	74	0	0	89	0	0	0	0	0	16	15
Lead / Lag	-	-	-	-	-	-	-	-	-	-	-	-
Minimum Green [s]	0	11	0	0	8	0	0	0	0	0	4	4
Vehicle Extension [s]	0.0	0.0	0.0	0.0	0.0	0.0	0.0	0.0	0.0	0.0	0.0	0.0
Minimum Recall		Yes			Yes						No	No
Maximum Recall		No			No						No	No
Pedestrian Recall		No			No						No	No

**Exclusive Pedestrian Phase**

Pedestrian Signal Group	0
Pedestrian Walk [s]	0
Pedestrian Clearance [s]	0



**Lane Group Calculations**

Lane Group	C	C		L	C	R
C, Cycle Length [s]	105	105		105	105	105
L, Total Lost Time per Cycle [s]	4.00	4.00		4.00	4.00	4.00
l1_p, Permitted Start-Up Lost Time [s]	0.00	0.00		0.00	0.00	0.00
l2, Clearance Lost Time [s]	2.00	2.00		2.00	2.00	0.00
g_i, Effective Green Time [s]	70	85		12	12	27
g / C, Green / Cycle	0.67	0.81		0.11	0.11	0.26
(v / s)_i Volume / Saturation Flow Rate	0.22	0.04		0.02	0.02	0.12
s, saturation flow rate [veh/h]	3535	4943		1749	1810	2667
c, Capacity [veh/h]	2356	4000		200	207	711
d1, Uniform Delay [s]	7.44	1.99		41.81	41.79	32.14
k, delay calibration	0.50	0.50		0.04	0.04	0.04
l, Upstream Filtering Factor	1.00	1.00		1.00	1.00	1.00
d2, Incremental Delay [s]	0.37	0.02		0.11	0.11	0.17
d3, Initial Queue Delay [s]	0.00	0.00		0.00	0.00	0.00
Rp, platoon ratio	1.00	1.00		1.00	1.00	1.00
PF, progression factor	1.00	1.00		1.00	1.00	1.00

**Lane Group Results**

X, volume / capacity	0.32	0.05		0.14	0.13	0.46
d, Delay for Lane Group [s/veh]	7.81	2.01		41.92	41.89	32.31
Lane Group LOS	A	A		D	D	C
Critical Lane Group	Yes	No		No	No	Yes
50th-Percentile Queue Length [veh/ln]	3.23	0.16		0.63	0.63	3.33
50th-Percentile Queue Length [ft/ln]	80.77	3.97		15.71	15.69	83.14
95th-Percentile Queue Length [veh/ln]	5.82	0.29		1.13	1.13	5.99
95th-Percentile Queue Length [ft/ln]	145.39	7.14		28.27	28.25	149.64

**Movement, Approach, & Intersection Results**

d_M, Delay for Movement [s/veh]	0.00	7.81	0.00	0.00	2.01	0.00	0.00	0.00	0.00	0.00	41.92	41.89	32.31
Movement LOS		A			A						D	D	C
d_A, Approach Delay [s/veh]	6.67		0.70			0.00			33.70				
Approach LOS	A		A			A			C				
d_I, Intersection Delay [s/veh]	13.48												
Intersection LOS	B												
Intersection V/C	0.253												

**Emissions**

Vehicle Miles Traveled [mph]	63.73	23.15	2.70	2.70	32.06
Stops [stops/h]	221.61	16.32	21.55	21.53	228.09
Fuel consumption [US gal/h]	5.67	1.07	0.60	0.59	6.08
CO [g/h]	396.63	74.76	41.61	41.58	424.88
NOx [g/h]	77.17	14.54	8.09	8.09	82.67
VOC [g/h]	91.92	17.33	9.64	9.64	98.47

**Other Modes**

g_Walk,mi, Effective Walk Time [s]	0.0	0.0	0.0	11.0
M_corner, Corner Circulation Area [ft <sup>2</sup> /ped]	0.00	0.00	0.00	0.00
M_CW, Crosswalk Circulation Area [ft <sup>2</sup> /ped]	0.00	0.00	0.00	0.00
d_p, Pedestrian Delay [s]	0.00	0.00	0.00	42.06
I_p,int, Pedestrian LOS Score for Intersectio	0.000	0.000	0.000	2.419
Crosswalk LOS	F	F	F	B
s_b, Saturation Flow Rate of the bicycle lane	2000	2000	2000	2000
c_b, Capacity of the bicycle lane [bicycles/h]	1309	1595	0	229
d_b, Bicycle Delay [s]	6.27	2.15	52.49	41.17
I_b,int, Bicycle LOS Score for Intersection	2.190	1.667	4.132	2.188
Bicycle LOS	B	A	D	B

**Sequence**

Ring 1	1	2	-	-	-	-	-	-	-	-	-	-	-	-	-	-
Ring 2	-	6	-	8	-	-	-	-	-	-	-	-	-	-	-	-
Ring 3	-	-	-	-	-	-	-	-	-	-	-	-	-	-	-	-
Ring 4	-	-	-	-	-	-	-	-	-	-	-	-	-	-	-	-



Vistro File: H:\...\PacVest\_20240229.vistro

Scenario 4 Near Term PM

Report File: H:\...\NearTermPM\_LOS.pdf

3/1/2024

**Intersection Analysis Summary**

ID	Intersection Name	Control Type	Method	Worst Mvmt	V/C	Delay (s/veh)	LOS
1	Hacienda Drive & Dublin Boulevard	Signalized	HCM 7th Edition	SB Left	0.465	39.7	D
2	Tassajara Road & Central Parkway	Signalized	HCM 7th Edition	SB Left	0.551	32.0	C
3	Tassajara Road & Dublin Boulevard	Signalized	HCM 7th Edition	NB Right	0.835	51.5	D
4	Tassajara Road & I-580 WB Ramps	Signalized	HCM 7th Edition	WB Left	0.674	11.5	B
5	Santa Rita Rd & I-580 EB Ramps/Pimlico Dr	Signalized	HCM 7th Edition	SB Left	0.849	35.0	D
6	Tassajara Road & Fallon Road	Signalized	HCM 7th Edition	WB Left	0.426	15.6	B
7	Fallon Road & Positano Parkway	Signalized	HCM 7th Edition	SB Left	0.555	10.7	B
8	Fallon Road & Central Parkway	Signalized	HCM 7th Edition	SB Left	0.398	21.2	C
9	Fallon Road & Dublin Boulevard	Signalized	HCM 7th Edition	EB Left	0.680	34.2	C
10	Fallon Road & Fallon Gateway	Signalized	HCM 7th Edition	NB Left	0.625	13.4	B
11	Fallon Road & I-580 WB Ramps	Signalized	HCM 7th Edition	NB Thru	0.586	24.5	C
12	El Charro Road & I-580 EB Ramps	Signalized	HCM 7th Edition	EB Right	0.602	7.2	A
13	El Charro Road & Jack London Boulevard	Signalized	HCM 7th Edition	NB Right	0.719	13.9	B
14	Central Parkway & Sunset View Drive	Signalized	HCM 7th Edition	WB Left	0.260	11.2	B
15	Central Parkway & Panorama Drive/Pino Grande Road	All-way stop	HCM 7th Edition	EB Left	0.146	8.0	A
16	Airway Boulevard & N. Canyons Parkway	Signalized	HCM 7th Edition	SB Thru	0.618	25.1	C
17	Airway Boulevard & I-580 WB Ramps	Signalized	HCM 7th Edition	WB Left	0.251	9.0	A



V/C, Delay, LOS: For two-way stop, these values are taken from the movement with the worst (highest) delay value. For all other control types, they are taken for the whole intersection.

**Intersection Level Of Service Report**  
**Intersection 1: Hacienda Drive & Dublin Boulevard**

Control Type:	Signalized	Delay (sec / veh):	39.7
Analysis Method:	HCM 7th Edition	Level Of Service:	D
Analysis Period:	15 minutes	Volume to Capacity (v/c):	0.465

**Intersection Setup**

Name	Hacienda Drive			Hacienda Drive			Dublin Boulevard			Dublin Boulevard		
Approach	Northbound			Southbound			Eastbound			Westbound		
Lane Configuration	[Diagram]			[Diagram]			[Diagram]			[Diagram]		
Turning Movement	Left	Thru	Right	Left	Thru	Right	Left	Thru	Right	Left	Thru	Right
Lane Width [ft]	12.00	12.00	12.00	12.00	12.00	12.00	12.00	12.00	12.00	12.00	12.00	12.00
No. of Lanes in Entry Pocket	2	0	2	2	0	1	2	0	2	2	0	0
Entry Pocket Length [ft]	250.00	100.00	380.00	300.00	100.00	220.00	300.00	100.00	250.00	275.00	100.00	100.00
No. of Lanes in Exit Pocket	0	0	0	0	0	0	0	0	0	0	0	1
Exit Pocket Length [ft]	0.00	0.00	0.00	0.00	0.00	0.00	0.00	0.00	0.00	0.00	0.00	1000.00
Speed [mph]	35.00			35.00			40.00			40.00		
Grade [%]	0.00			0.00			0.00			0.00		
Curb Present	Yes			Yes			Yes			Yes		
Crosswalk	Yes			Yes			Yes			Yes		



**Volumes**

Name	Hacienda Drive			Hacienda Drive			Dublin Boulevard			Dublin Boulevard		
Base Volume Input [veh/h]	199	596	276	55	504	59	144	888	284	167	529	20
Base Volume Adjustment Factor	1.0000	1.0000	1.0000	1.0000	1.0000	1.0000	1.0000	1.0000	1.0000	1.0000	1.0000	1.0000
Heavy Vehicles Percentage [%]	0.00	0.20	0.80	0.00	0.20	5.10	1.90	1.10	1.50	1.30	1.60	0.00
Proportion of CAVs [%]	0.00											
Growth Factor	1.0000	1.0000	1.0000	1.0000	1.0000	1.0000	1.0000	1.0000	1.0000	1.0000	1.0000	1.0000
In-Process Volume [veh/h]	0	0	0	0	0	0	0	0	0	0	0	0
Site-Generated Trips [veh/h]	0	0	0	0	0	0	0	0	0	0	0	0
Diverted Trips [veh/h]	0	0	0	0	0	0	0	0	0	0	0	0
Pass-by Trips [veh/h]	0	0	0	0	0	0	0	0	0	0	0	0
Existing Site Adjustment Volume [veh/h]	0	0	0	0	0	0	0	0	0	0	0	0
Other Volume [veh/h]	0	0	0	0	0	0	0	0	0	0	0	0
Right Turn on Red Volume [veh/h]	0	0	0	0	0	0	0	0	0	0	0	0
Total Hourly Volume [veh/h]	199	596	276	55	504	59	144	888	284	167	529	20
Peak Hour Factor	0.9400	0.9400	0.9400	0.9400	0.9400	0.9400	0.9400	0.9400	0.9400	0.9400	0.9400	0.9400
Other Adjustment Factor	1.0000	1.0000	1.0000	1.0000	1.0000	1.0000	1.0000	1.0000	1.0000	1.0000	1.0000	1.0000
Total 15-Minute Volume [veh/h]	53	159	73	15	134	16	38	236	76	44	141	5
Total Analysis Volume [veh/h]	212	634	294	59	536	63	153	945	302	178	563	21
Presence of On-Street Parking	No		No	No		No	No		No	No		No
On-Street Parking Maneuver Rate [/h]	0	0	0	0	0	0	0	0	0	0	0	0
Local Bus Stopping Rate [/h]	0	0	0	0	0	0	0	0	0	0	0	0
v_do, Outbound Pedestrian Volume crossing	5			2			4			2		
v_di, Inbound Pedestrian Volume crossing m	4			2			5			2		
v_co, Outbound Pedestrian Volume crossing	6			1			2			7		
v_ci, Inbound Pedestrian Volume crossing mi	7			2			1			6		
v_ab, Corner Pedestrian Volume [ped/h]	0			0			0			0		
Bicycle Volume [bicycles/h]	1			0			4			1		





**Intersection Settings**

Located in CBD	No
Signal Coordination Group	-
Cycle Length [s]	150
Active Pattern	Pattern 1
Coordination Type	Time of Day Pattern Coordinated
Actuation Type	Fully actuated
Offset [s]	113.0
Offset Reference	Lead Green - Beginning of First Green
Permissive Mode	SingleBand
Lost time [s]	12.00

**Phasing & Timing (Basic)**

Control Type	Protecte	Permiss	Permiss	Protecte	Permiss	Permiss	Protecte	Permiss	Permiss	Protecte	Permiss	Permiss
Signal Group	3	8	0	7	4	0	5	2	0	1	6	0
Auxiliary Signal Groups												
Maximum Green [s]	20	50	0	20	50	0	20	60	0	20	60	0
Amber [s]	3.5	4.5	0.0	3.5	4.1	0.0	3.5	4.5	0.0	3.5	4.5	0.0
All red [s]	1.5	1.5	0.0	1.0	1.5	0.0	1.0	1.5	0.0	1.0	1.5	0.0
Walk [s]	0	4	0	0	4	0	0	4	0	0	4	0
Pedestrian Clearance [s]	0	32	0	0	40	0	0	43	0	0	35	0
Delayed Vehicle Green [s]	0.0	0.0	0.0	0.0	0.0	0.0	0.0	0.0	0.0	0.0	0.0	0.0
Rest In Walk		No			No			No			No	
I1, Start-Up Lost Time [s]	2.0	2.0	0.0	2.0	2.0	0.0	2.0	2.0	0.0	2.0	2.0	0.0
I2, Clearance Lost Time [s]	2.0	2.0	0.0	2.0	2.0	0.0	2.0	2.0	0.0	2.0	2.0	0.0
Detector Location [ft]	0.0	0.0	0.0	0.0	0.0	0.0	0.0	0.0	0.0	0.0	0.0	0.0
Detector Length [ft]	20.0	20.0	0.0	20.0	20.0	0.0	20.0	20.0	0.0	20.0	20.0	0.0
I, Upstream Filtering Factor	1.00	1.00	1.00	1.00	1.00	1.00	1.00	1.00	1.00	1.00	1.00	1.00

**Phasing & Timing: Pattern 1**

Split [s]	18	55	0	14	51	0	15	61	0	20	66	0
Lead / Lag	Lead	-	-	Lead	-	-	Lead	-	-	Lead	-	-
Minimum Green [s]	4	10	0	4	10	0	4	10	0	8	10	0
Vehicle Extension [s]	3.0	3.5	0.0	3.0	3.5	0.0	3.0	3.5	0.0	3.0	3.5	0.0
Minimum Recall	No	No		No	No		No	Yes		No	Yes	
Maximum Recall	No	No		No	No		No	No		No	No	
Pedestrian Recall	No	No		No	No		No	No		No	No	

**Exclusive Pedestrian Phase**

Pedestrian Signal Group	0
Pedestrian Walk [s]	0
Pedestrian Clearance [s]	0



**Lane Group Calculations**

Lane Group	L	C	R	L	C	R	L	C	R	L	C	C
C, Cycle Length [s]	150	150	150	150	150	150	150	150	150	150	150	150
L, Total Lost Time per Cycle [s]	4.00	4.00	4.00	4.00	4.00	4.00	4.00	4.00	4.00	4.00	4.00	4.00
l1_p, Permitted Start-Up Lost Time [s]	0.00	0.00	0.00	0.00	0.00	0.00	0.00	0.00	0.00	0.00	0.00	0.00
l2, Clearance Lost Time [s]	2.00	2.00	2.00	2.00	2.00	2.00	2.00	2.00	2.00	2.00	2.00	2.00
g_i, Effective Green Time [s]	9	34	34	5	30	30	9	85	85	10	86	86
g / C, Green / Cycle	0.06	0.23	0.23	0.03	0.20	0.20	0.06	0.57	0.57	0.07	0.57	0.57
(v / s)_i Volume / Saturation Flow Rate	0.04	0.18	0.11	0.02	0.10	0.04	0.04	0.18	0.11	0.05	0.11	0.11
s, saturation flow rate [veh/h]	5271	3612	2756	3514	5167	1543	3461	5131	2773	3478	3572	1838
c, Capacity [veh/h]	325	823	628	110	1021	305	211	2900	1568	240	2048	1054
d1, Uniform Delay [s]	68.83	54.26	49.90	71.61	53.92	50.37	69.24	17.39	15.88	68.57	15.32	15.33
k, delay calibration	0.11	0.13	0.13	0.11	0.13	0.13	0.11	0.50	0.50	0.11	0.50	0.50
l, Upstream Filtering Factor	1.00	1.00	1.00	1.00	1.00	1.00	1.00	1.00	1.00	1.00	1.00	1.00
d2, Incremental Delay [s]	2.20	1.88	0.66	3.99	0.51	0.40	4.71	0.30	0.27	4.51	0.20	0.40
d3, Initial Queue Delay [s]	0.00	0.00	0.00	0.00	0.00	0.00	0.00	0.00	0.00	0.00	0.00	0.00
Rp, platoon ratio	1.00	1.00	1.00	1.00	1.00	1.00	1.00	1.00	1.00	1.00	1.00	1.00
PF, progression factor	1.00	1.00	1.00	1.00	1.00	1.00	1.00	1.00	1.00	1.00	1.00	1.00

**Lane Group Results**

X, volume / capacity	0.65	0.77	0.47	0.54	0.53	0.21	0.73	0.33	0.19	0.74	0.19	0.19
d, Delay for Lane Group [s/veh]	71.04	56.14	50.56	75.61	54.42	50.77	73.95	17.69	16.16	73.08	15.52	15.72
Lane Group LOS	E	E	D	E	D	D	E	B	B	E	B	B
Critical Lane Group	No	Yes	No	Yes	No	No	No	Yes	No	Yes	No	No
50th-Percentile Queue Length [veh/ln]	2.72	11.39	4.82	1.18	6.10	2.03	3.00	5.78	2.56	3.48	3.17	3.34
50th-Percentile Queue Length [ft/ln]	67.93	284.85	120.62	29.48	152.42	50.67	75.10	144.50	63.88	86.95	79.21	83.50
95th-Percentile Queue Length [veh/ln]	4.89	16.93	8.43	2.12	10.15	3.65	5.41	9.72	4.60	6.26	5.70	6.01
95th-Percentile Queue Length [ft/ln]	122.27	423.25	210.68	53.07	253.66	91.20	135.18	243.07	114.99	156.50	142.58	150.30



**Movement, Approach, & Intersection Results**

d_M, Delay for Movement [s/veh]	71.04	56.14	50.56	75.61	54.42	50.77	73.95	17.69	16.16	73.08	15.58	15.72
Movement LOS	E	E	D	E	D	D	E	B	B	E	B	B
d_A, Approach Delay [s/veh]	57.47			55.97			23.50			29.02		
Approach LOS	E			E			C			C		
d_I, Intersection Delay [s/veh]	39.74											
Intersection LOS	D											
Intersection V/C	0.465											

**Emissions**

Vehicle Miles Traveled [mph]	21.51	64.34	29.84	6.87	62.39	7.33	17.49	108.01	34.52	156.52	338.34	175.18
Stops [stops/h]	195.58	546.77	231.53	56.59	438.86	48.63	144.15	416.04	122.62	166.89	152.04	80.14
Fuel consumption [US gal/h]	5.36	13.81	5.90	1.60	11.61	1.30	4.34	11.36	3.43	9.89	14.83	7.70
CO [g/h]	374.32	965.05	412.60	111.49	811.82	90.59	303.69	793.86	240.03	691.51	1036.49	538.23
NOx [g/h]	72.83	187.76	80.28	21.69	157.95	17.63	59.09	154.46	46.70	134.54	201.66	104.72
VOC [g/h]	86.75	223.66	95.63	25.84	188.15	21.00	70.38	183.98	55.63	160.26	240.22	124.74

**Other Modes**

g_Walk,mi, Effective Walk Time [s]	8.0			8.0			8.0			8.0		
M_corner, Corner Circulation Area [ft <sup>2</sup> /ped]	0.00			0.00			0.00			0.00		
M_CW, Crosswalk Circulation Area [ft <sup>2</sup> /ped]	274.16			1167.32			1473.17			148.44		
d_p, Pedestrian Delay [s]	67.23			67.23			67.23			67.23		
I_p,int, Pedestrian LOS Score for Intersectio	3.238			2.960			3.283			3.086		
Crosswalk LOS	C			C			C			C		
s_b, Saturation Flow Rate of the bicycle lane	2000			2000			2000			2000		
c_b, Capacity of the bicycle lane [bicycles/h]	653			605			733			800		
d_b, Bicycle Delay [s]	34.04			36.49			30.16			27.03		
I_b,int, Bicycle LOS Score for Intersection	2.500			1.922			2.330			1.979		
Bicycle LOS	B			A			B			A		

**Sequence**

Ring 1	1	2	3	4	-	-	-	-	-	-	-	-	-	-	-
Ring 2	5	6	7	8	-	-	-	-	-	-	-	-	-	-	-
Ring 3	-	-	-	-	-	-	-	-	-	-	-	-	-	-	-
Ring 4	-	-	-	-	-	-	-	-	-	-	-	-	-	-	-

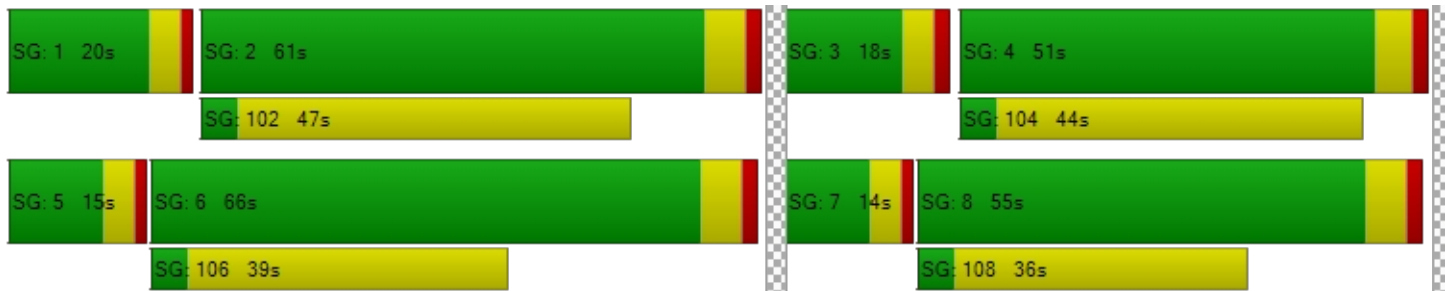

**Intersection Level Of Service Report**  
**Intersection 2: Tassajara Road & Central Parkway**

Control Type:	Signalized	Delay (sec / veh):	32.0
Analysis Method:	HCM 7th Edition	Level Of Service:	C
Analysis Period:	15 minutes	Volume to Capacity (v/c):	0.551

**Intersection Setup**

Name	Tassajara Road			Tassajara Road			Central Parkway			Central Parkway		
Approach	Northbound			Southbound			Eastbound			Westbound		
Lane Configuration												
Turning Movement	Left	Thru	Right	Left	Thru	Right	Left	Thru	Right	Left	Thru	Right
Lane Width [ft]	12.00	12.00	12.00	12.00	12.00	12.00	12.00	12.00	12.00	12.00	12.00	12.00
No. of Lanes in Entry Pocket	1	0	1	1	0	1	1	0	1	2	0	0
Entry Pocket Length [ft]	325.00	100.00	325.00	300.00	100.00	215.00	225.00	100.00	225.00	300.00	100.00	100.00
No. of Lanes in Exit Pocket	0	0	0	0	0	0	0	0	0	0	0	0
Exit Pocket Length [ft]	0.00	0.00	0.00	0.00	0.00	0.00	0.00	0.00	0.00	0.00	0.00	0.00
Speed [mph]	40.00			40.00			35.00			35.00		
Grade [%]	0.00			0.00			0.00			0.00		
Curb Present	Yes			Yes			Yes			Yes		
Crosswalk	Yes			Yes			Yes			Yes		



**Volumes**

Name	Tassajara Road			Tassajara Road			Central Parkway			Central Parkway		
Base Volume Input [veh/h]	68	912	182	23	860	42	69	230	129	168	104	23
Base Volume Adjustment Factor	1.0000	1.0000	1.0000	1.0000	1.0000	1.0000	1.0000	1.0000	1.0000	1.0000	1.0000	1.0000
Heavy Vehicles Percentage [%]	0.00	0.10	0.00	0.00	0.60	0.00	0.00	0.00	0.00	0.00	0.00	0.00
Proportion of CAVs [%]	0.00											
Growth Factor	1.0000	1.0000	1.0000	1.0000	1.0000	1.0000	1.0000	1.0000	1.0000	1.0000	1.0000	1.0000
In-Process Volume [veh/h]	0	0	0	0	0	0	0	0	0	0	0	0
Site-Generated Trips [veh/h]	0	0	0	0	0	0	0	0	0	0	0	0
Diverted Trips [veh/h]	0	0	0	0	0	0	0	0	0	0	0	0
Pass-by Trips [veh/h]	0	0	0	0	0	0	0	0	0	0	0	0
Existing Site Adjustment Volume [veh/h]	0	0	0	0	0	0	0	0	0	0	0	0
Other Volume [veh/h]	0	0	0	0	0	0	0	0	0	0	0	0
Right Turn on Red Volume [veh/h]	0	0	0	0	0	0	0	0	0	0	0	0
Total Hourly Volume [veh/h]	68	912	182	23	860	42	69	230	129	168	104	23
Peak Hour Factor	0.8900	0.8900	0.8900	0.8900	0.8900	0.8900	0.8900	0.8900	0.8900	0.8900	0.8900	0.8900
Other Adjustment Factor	1.0000	1.0000	1.0000	1.0000	1.0000	1.0000	1.0000	1.0000	1.0000	1.0000	1.0000	1.0000
Total 15-Minute Volume [veh/h]	19	256	51	6	242	12	19	65	36	47	29	6
Total Analysis Volume [veh/h]	76	1025	204	26	966	47	78	258	145	189	117	26
Presence of On-Street Parking	No		No	No		No	No		No	No		No
On-Street Parking Maneuver Rate [/h]	0	0	0	0	0	0	0	0	0	0	0	0
Local Bus Stopping Rate [/h]	0	0	0	0	0	0	0	0	0	0	0	0
v_do, Outbound Pedestrian Volume crossing	2			1			2			0		
v_di, Inbound Pedestrian Volume crossing m	2			0			2			1		
v_co, Outbound Pedestrian Volume crossing	0			4			5			0		
v_ci, Inbound Pedestrian Volume crossing mi	0			5			4			0		
v_ab, Corner Pedestrian Volume [ped/h]	0			0			0			0		
Bicycle Volume [bicycles/h]	1			1			0			0		



**Intersection Settings**

Located in CBD	No
Signal Coordination Group	-
Cycle Length [s]	130
Active Pattern	Pattern 1
Coordination Type	Time of Day Pattern Coordinated
Actuation Type	Fully actuated
Offset [s]	124.0
Offset Reference	Lead Green - Beginning of First Green
Permissive Mode	SingleBand
Lost time [s]	12.00

**Phasing & Timing (Basic)**

Control Type	Protecte	Permiss	Permiss	Protecte	Permiss	Permiss	Protecte	Permiss	Permiss	Protecte	Permiss	Permiss
Signal Group	3	8	0	7	4	0	5	2	0	1	6	0
Auxiliary Signal Groups												
Maximum Green [s]	20	40	0	20	40	0	20	20	0	20	20	0
Amber [s]	3.5	4.3	0.0	3.5	4.3	0.0	3.5	4.1	0.0	3.5	4.1	0.0
All red [s]	1.0	1.0	0.0	1.0	1.0	0.0	1.0	1.0	0.0	1.0	1.0	0.0
Walk [s]	0	4	0	0	4	0	0	4	0	0	4	0
Pedestrian Clearance [s]	0	20	0	0	24	0	0	36	0	0	30	0
Delayed Vehicle Green [s]	0.0	0.0	0.0	0.0	0.0	0.0	0.0	0.0	0.0	0.0	0.0	0.0
Rest In Walk		No			No			No			No	
I1, Start-Up Lost Time [s]	2.0	2.0	0.0	2.0	2.0	0.0	2.0	2.0	0.0	2.0	2.0	0.0
I2, Clearance Lost Time [s]	2.5	3.3	0.0	2.5	3.3	0.0	2.5	3.1	0.0	2.5	3.1	0.0
Detector Location [ft]	0.0	0.0	0.0	0.0	0.0	0.0	0.0	0.0	0.0	0.0	0.0	0.0
Detector Length [ft]	20.0	20.0	0.0	20.0	20.0	0.0	20.0	20.0	0.0	20.0	20.0	0.0
I, Upstream Filtering Factor	1.00	1.00	1.00	1.00	1.00	1.00	1.00	1.00	1.00	1.00	1.00	1.00

**Phasing & Timing: Pattern 1**

Split [s]	18	48	0	18	48	0	18	45	0	19	46	0
Lead / Lag	Lead	-	-	Lead	-	-	Lead	-	-	Lead	-	-
Minimum Green [s]	13	12	0	13	12	0	13	13	0	14	13	0
Vehicle Extension [s]	2.5	4.0	0.0	2.5	4.0	0.0	2.5	2.5	0.0	2.5	2.5	0.0
Minimum Recall	No	Yes		No	Yes		No	No		No	No	
Maximum Recall	No	No		No	No		No	No		No	No	
Pedestrian Recall	No	No		No	No		No	No		No	No	

**Exclusive Pedestrian Phase**

Pedestrian Signal Group	0
Pedestrian Walk [s]	0
Pedestrian Clearance [s]	0



**Lane Group Calculations**

Lane Group	L	C	R	L	C	R	L	C	R	L	C
C, Cycle Length [s]	130	130	130	130	130	130	130	130	130	130	130
L, Total Lost Time per Cycle [s]	4.50	5.30	5.30	4.50	5.30	5.30	4.50	5.10	5.10	4.50	5.10
l1_p, Permitted Start-Up Lost Time [s]	0.00	0.00	0.00	0.00	0.00	0.00	0.00	0.00	0.00	0.00	0.00
l2, Clearance Lost Time [s]	2.50	3.30	3.30	2.50	3.30	3.30	2.50	3.10	3.10	2.50	3.10
g_i, Effective Green Time [s]	12	67	67	8	63	63	12	21	21	14	23
g / C, Green / Cycle	0.09	0.52	0.52	0.06	0.49	0.49	0.09	0.16	0.16	0.11	0.18
(v / s)_i Volume / Saturation Flow Rate	0.04	0.28	0.13	0.01	0.27	0.03	0.04	0.14	0.09	0.05	0.08
s, saturation flow rate [veh/h]	1810	3615	1582	1810	3600	1567	1810	1900	1603	3514	1840
c, Capacity [veh/h]	170	1871	818	111	1746	760	171	311	262	380	326
d1, Uniform Delay [s]	55.65	21.11	17.31	58.05	23.55	17.75	55.66	52.58	49.92	54.62	47.68
k, delay calibration	0.08	0.50	0.50	0.08	0.50	0.50	0.08	0.08	0.08	0.08	0.08
l, Upstream Filtering Factor	1.00	1.00	1.00	1.00	1.00	1.00	1.00	1.00	1.00	1.00	1.00
d2, Incremental Delay [s]	1.36	1.16	0.73	0.79	1.27	0.16	1.41	4.28	1.35	0.75	0.69
d3, Initial Queue Delay [s]	0.00	0.00	0.00	0.00	0.00	0.00	0.00	0.00	0.00	0.00	0.00
Rp, platoon ratio	1.00	1.00	1.00	1.00	1.00	1.00	1.00	1.00	1.00	1.00	1.00
PF, progression factor	1.00	1.00	1.00	1.00	1.00	1.00	1.00	1.00	1.00	1.00	1.00

**Lane Group Results**

X, volume / capacity	0.45	0.55	0.25	0.23	0.55	0.06	0.46	0.83	0.55	0.50	0.44
d, Delay for Lane Group [s/veh]	57.02	22.27	18.04	58.83	24.82	17.90	57.07	56.86	51.27	55.37	48.37
Lane Group LOS	E	C	B	E	C	B	E	E	D	E	D
Critical Lane Group	Yes	No	No	No	Yes	No	No	Yes	No	Yes	No
50th-Percentile Queue Length [veh/ln]	2.39	10.36	3.45	0.83	10.37	0.77	2.48	8.45	4.41	2.95	4.18
50th-Percentile Queue Length [ft/ln]	59.87	259.09	86.25	20.76	259.25	19.27	61.96	211.31	110.28	73.64	104.61
95th-Percentile Queue Length [veh/ln]	4.31	15.64	6.21	1.49	15.65	1.39	4.46	13.22	7.86	5.30	7.53
95th-Percentile Queue Length [ft/ln]	107.77	391.08	155.25	37.36	391.27	34.69	111.54	330.51	196.40	132.55	188.30



**Movement, Approach, & Intersection Results**

d_M, Delay for Movement [s/veh]	57.02	22.27	18.04	58.83	24.82	17.90	57.07	56.86	51.27	55.37	48.37	48.37
Movement LOS	E	C	B	E	C	B	E	E	D	E	D	D
d_A, Approach Delay [s/veh]	23.63			25.35			55.21			52.36		
Approach LOS	C			C			E			D		
d_I, Intersection Delay [s/veh]	32.03											
Intersection LOS	C											
Intersection V/C	0.551											

**Emissions**

Vehicle Miles Traveled [mph]	21.92	295.60	58.83	4.95	183.76	8.94	10.26	33.95	19.08	25.63	19.39
Stops [stops/h]	66.34	574.17	95.57	23.00	574.51	21.35	68.66	234.14	122.20	163.20	115.91
Fuel consumption [US gal/h]	2.32	20.87	3.80	0.71	17.10	0.70	1.81	6.04	3.16	4.33	3.02
CO [g/h]	162.06	1459.06	265.27	49.93	1195.59	49.02	126.76	422.19	220.81	302.93	210.99
NOx [g/h]	31.53	283.88	51.61	9.72	232.62	9.54	24.66	82.14	42.96	58.94	41.05
VOC [g/h]	37.56	338.15	61.48	11.57	277.09	11.36	29.38	97.85	51.18	70.21	48.90

**Other Modes**

g_Walk,mi, Effective Walk Time [s]	8.0			8.0			8.0			8.0		
M_corner, Corner Circulation Area [ft <sup>2</sup> /ped]	0.00			0.00			0.00			0.00		
M_CW, Crosswalk Circulation Area [ft <sup>2</sup> /ped]	1064.33			5332.37			497.83			0.00		
d_p, Pedestrian Delay [s]	57.23			57.23			57.23			57.23		
I_p,int, Pedestrian LOS Score for Intersectio	3.168			2.942			2.356			2.384		
Crosswalk LOS	C			C			B			B		
s_b, Saturation Flow Rate of the bicycle lane	2000			2000			2000			2000		
c_b, Capacity of the bicycle lane [bicycles/h]	657			657			614			629		
d_b, Bicycle Delay [s]	29.31			29.31			31.20			30.52		
I_b,int, Bicycle LOS Score for Intersection	2.636			2.417			2.353			2.107		
Bicycle LOS	B			B			B			B		

**Sequence**

Ring 1	1	2	3	4	-	-	-	-	-	-	-	-	-	-	-
Ring 2	5	6	7	8	-	-	-	-	-	-	-	-	-	-	-
Ring 3	-	-	-	-	-	-	-	-	-	-	-	-	-	-	-
Ring 4	-	-	-	-	-	-	-	-	-	-	-	-	-	-	-





**Intersection Level Of Service Report**  
**Intersection 3: Tassajara Road & Dublin Boulevard**

Control Type:	Signalized	Delay (sec / veh):	51.5
Analysis Method:	HCM 7th Edition	Level Of Service:	D
Analysis Period:	15 minutes	Volume to Capacity (v/c):	0.835

**Intersection Setup**

Name	Tassajara Road			Tassajara Road			Dublin Boulevard			Dublin Boulevard		
Approach	Northbound			Southbound			Eastbound			Westbound		
Lane Configuration	[Diagram]			[Diagram]			[Diagram]			[Diagram]		
Turning Movement	Left	Thru	Right	Left	Thru	Right	Left	Thru	Right	Left	Thru	Right
Lane Width [ft]	12.00	12.00	12.00	12.00	12.00	12.00	12.00	12.00	12.00	12.00	12.00	12.00
No. of Lanes in Entry Pocket	3	0	1	2	0	2	2	0	2	3	0	0
Entry Pocket Length [ft]	380.00	100.00	250.00	295.00	100.00	290.00	265.00	100.00	330.00	395.00	100.00	100.00
No. of Lanes in Exit Pocket	0	0	1	0	0	0	0	0	0	0	0	0
Exit Pocket Length [ft]	0.00	0.00	49.21	0.00	0.00	0.00	0.00	0.00	0.00	0.00	0.00	0.00
Speed [mph]	30.00			40.00			40.00			40.00		
Grade [%]	0.00			0.00			0.00			0.00		
Curb Present	Yes			Yes			Yes			Yes		
Crosswalk	Yes			Yes			Yes			Yes		



**Volumes**

Name	Tassajara Road			Tassajara Road			Dublin Boulevard			Dublin Boulevard		
Base Volume Input [veh/h]	303	781	596	143	958	125	259	589	469	526	351	44
Base Volume Adjustment Factor	1.0000	1.0000	1.0000	1.0000	1.0000	1.0000	1.0000	1.0000	1.0000	1.0000	1.0000	1.0000
Heavy Vehicles Percentage [%]	0.70	0.00	0.00	1.20	0.40	0.00	0.40	0.80	13.00	0.20	1.30	0.00
Proportion of CAVs [%]	0.00											
Growth Factor	1.0000	1.0000	1.0000	1.0000	1.0000	1.0000	1.0000	1.0000	1.0000	1.0000	1.0000	1.0000
In-Process Volume [veh/h]	0	0	0	0	0	0	0	0	0	0	0	0
Site-Generated Trips [veh/h]	0	0	0	0	0	0	0	0	0	0	0	0
Diverted Trips [veh/h]	0	0	0	0	0	0	0	0	0	0	0	0
Pass-by Trips [veh/h]	0	0	0	0	0	0	0	0	0	0	0	0
Existing Site Adjustment Volume [veh/h]	0	0	0	0	0	0	0	0	0	0	0	0
Other Volume [veh/h]	0	0	0	0	0	0	0	0	0	0	0	0
Right Turn on Red Volume [veh/h]	0	0	0	0	0	0	0	0	0	0	0	0
Total Hourly Volume [veh/h]	303	781	596	143	958	125	259	589	469	526	351	44
Peak Hour Factor	0.9100	0.9100	0.9100	0.9100	0.9100	0.9100	0.9100	0.9100	0.9100	0.9100	0.9100	0.9100
Other Adjustment Factor	1.0000	1.0000	1.0000	1.0000	1.0000	1.0000	1.0000	1.0000	1.0000	1.0000	1.0000	1.0000
Total 15-Minute Volume [veh/h]	83	215	164	39	263	34	71	162	129	145	96	12
Total Analysis Volume [veh/h]	333	858	655	157	1053	137	285	647	515	578	386	48
Presence of On-Street Parking	No		No	No		No	No		No	No		No
On-Street Parking Maneuver Rate [/h]	0	0	0	0	0	0	0	0	0	0	0	0
Local Bus Stopping Rate [/h]	0	0	0	0	0	0	0	0	0	0	0	0
v_do, Outbound Pedestrian Volume crossing	0			2			3			0		
v_di, Inbound Pedestrian Volume crossing m	0			3			2			0		
v_co, Outbound Pedestrian Volume crossing	0			4			0			3		
v_ci, Inbound Pedestrian Volume crossing mi	0			3			0			4		
v_ab, Corner Pedestrian Volume [ped/h]	0			0			0			0		
Bicycle Volume [bicycles/h]	1			0			1			0		



**Intersection Settings**

Located in CBD	No
Signal Coordination Group	-
Cycle Length [s]	90
Active Pattern	Free Running (No Pattern)
Coordination Type	<i>Free Running</i>
Actuation Type	<i>Fully actuated</i>
Offset [s]	0.0
Offset Reference	Lead Green - Beginning of First Green
Permissive Mode	SingleBand
Lost time [s]	12.00

**Phasing & Timing (Basic)**

Control Type	Protecte	Permiss	Permiss	Protecte	Permiss	Permiss	Protecte	Permiss	Overlap	Protecte	Permiss	Permiss
Signal Group	3	8	0	7	4	0	5	2	2	1	6	0
Auxiliary Signal Groups									2,3			
Maximum Green [s]	20	35	0	20	35	0	20	35	35	20	35	0
Amber [s]	3.5	4.5	0.0	3.5	4.5	0.0	3.5	4.5	4.5	3.5	4.5	0.0
All red [s]	1.5	1.5	0.0	1.5	1.5	0.0	1.5	1.5	1.5	1.5	1.5	0.0
Walk [s]	0	4	0	0	4	0	0	0	0	0	4	0
Pedestrian Clearance [s]	0	29	0	0	42	0	0	0	0	0	42	0
Delayed Vehicle Green [s]	0.0	0.0	0.0	0.0	0.0	0.0	0.0	0.0	0.0	0.0	0.0	0.0
Rest In Walk		No			No			No			No	
I1, Start-Up Lost Time [s]	2.0	2.0	0.0	2.0	2.0	0.0	2.0	2.0	2.0	2.0	2.0	0.0
I2, Clearance Lost Time [s]	2.0	2.0	0.0	2.0	2.0	0.0	2.0	2.0	2.0	2.0	2.0	0.0
Detector Location [ft]	0.0	0.0	0.0	0.0	0.0	0.0	0.0	0.0	0.0	0.0	0.0	0.0
Detector Length [ft]	20.0	20.0	0.0	20.0	20.0	0.0	20.0	20.0	20.0	20.0	20.0	0.0
I, Upstream Filtering Factor	1.00	1.00	1.00	1.00	1.00	1.00	1.00	1.00	1.00	1.00	1.00	1.00

**Phasing & Timing: Free Running (No Pattern)**

Split [s]	0	0	0	0	0	0	0	0	0	0	0	0
Lead / Lag	Lead	-	-	Lead	-	-	Lead	-	-	Lead	-	-
Minimum Green [s]	16	15	0	15	15	0	16	16	16	16	15	0
Vehicle Extension [s]	2.0	4.0	0.0	2.0	4.0	0.0	2.0	3.0	3.0	2.0	3.0	0.0
Minimum Recall	No	Yes		No	Yes		No	No	No	No	No	
Maximum Recall	No	No		No	No		No	No	No	No	No	
Pedestrian Recall	No	No		No	No		No	No	No	No	No	

**Exclusive Pedestrian Phase**

Pedestrian Signal Group	0
Pedestrian Walk [s]	0
Pedestrian Clearance [s]	0



**Lane Group Calculations**

Lane Group	L	C	R	L	C	R	L	C	R	L	C	C
C, Cycle Length [s]	112	112	112	112	112	112	112	112	112	112	112	112
L, Total Lost Time per Cycle [s]	4.00	4.00	4.00	4.00	4.00	4.00	4.00	4.00	4.00	4.00	4.00	4.00
l1_p, Permitted Start-Up Lost Time [s]	0.00	0.00	0.00	0.00	0.00	0.00	0.00	0.00	0.00	0.00	0.00	0.00
l2, Clearance Lost Time [s]	2.00	2.00	2.00	2.00	2.00	2.00	2.00	2.00	0.00	2.00	2.00	2.00
g_i, Effective Green Time [s]	20	37	37	16	33	33	17	26	50	17	27	27
g / C, Green / Cycle	0.17	0.33	0.33	0.14	0.30	0.30	0.15	0.24	0.45	0.15	0.24	0.24
(v / s)_i Volume / Saturation Flow Rate	0.06	0.24	0.41	0.05	0.15	0.05	0.08	0.18	0.20	0.11	0.12	0.12
s, saturation flow rate [veh/h]	5242	3618	1595	3481	6879	2844	3503	3595	2547	5263	1880	1804
c, Capacity [veh/h]	915	1190	525	492	2035	841	530	848	1113	796	444	426
d1, Uniform Delay [s]	40.92	33.20	37.51	43.41	32.93	29.29	44.10	40.03	22.28	45.51	37.20	37.21
k, delay calibration	0.04	0.15	0.50	0.04	0.15	0.15	0.04	0.11	0.11	0.04	0.11	0.11
l, Upstream Filtering Factor	1.00	1.00	1.00	1.00	1.00	1.00	1.00	1.00	1.00	1.00	1.00	1.00
d2, Incremental Delay [s]	0.09	1.19	127.13	0.14	0.29	0.13	0.32	1.45	0.30	0.48	0.87	0.91
d3, Initial Queue Delay [s]	0.00	0.00	0.00	0.00	0.00	0.00	0.00	0.00	0.00	0.00	0.00	0.00
Rp, platoon ratio	1.00	1.00	1.00	1.00	1.00	1.00	1.00	1.00	1.00	1.00	1.00	1.00
PF, progression factor	1.00	1.00	1.00	1.00	1.00	1.00	1.00	1.00	1.00	1.00	1.00	1.00

**Lane Group Results**

X, volume / capacity	0.36	0.72	1.25	0.32	0.52	0.16	0.54	0.76	0.46	0.73	0.50	0.50
d, Delay for Lane Group [s/veh]	41.01	34.39	164.64	43.55	33.22	29.42	44.42	41.48	22.58	45.98	38.06	38.11
Lane Group LOS	D	C	F	D	C	C	D	D	C	D	D	D
Critical Lane Group	No	No	Yes	Yes	No	No	No	Yes	No	Yes	No	No
50th-Percentile Queue Length [veh/ln]	2.72	10.36	32.55	1.94	5.84	1.36	3.62	8.27	4.64	5.05	5.25	5.06
50th-Percentile Queue Length [ft/ln]	68.02	258.88	813.82	48.47	145.90	33.91	90.41	206.72	115.88	126.21	131.33	126.46
95th-Percentile Queue Length [veh/ln]	4.90	15.63	47.88	3.49	9.80	2.44	6.51	12.98	8.17	8.73	9.01	8.75
95th-Percentile Queue Length [ft/ln]	122.43	390.81	1197.12	87.25	244.94	61.03	162.73	324.62	204.15	218.33	225.30	218.67



**Movement, Approach, & Intersection Results**

d_M, Delay for Movement [s/veh]	41.01	34.39	164.64	43.55	33.22	29.42	44.42	41.48	22.58	45.98	38.08	38.11
Movement LOS	D	C	F	D	C	C	D	D	C	D	D	D
d_A, Approach Delay [s/veh]	81.80			34.04			35.33			42.60		
Approach LOS	F			C			D			D		
d_I, Intersection Delay [s/veh]	51.50											
Intersection LOS	D											
Intersection V/C	0.835											

**Emissions**

Vehicle Miles Traveled [mph]	68.31	176.00	134.36	45.28	303.67	39.51	250.61	568.92	452.85	695.42	266.17	256.00
Stops [stops/h]	261.40	663.27	1042.54	124.18	747.62	86.87	231.64	529.65	296.90	485.03	168.24	162.00
Fuel consumption [US gal/h]	7.03	16.91	33.23	4.23	25.34	3.09	13.83	31.04	21.50	35.08	12.90	12.41
CO [g/h]	491.73	1182.34	2322.93	295.89	1771.30	215.91	966.60	2169.93	1503.17	2452.34	901.75	867.57
NOx [g/h]	95.67	230.04	451.96	57.57	344.63	42.01	188.07	422.19	292.46	477.14	175.45	168.80
VOC [g/h]	113.96	274.02	538.36	68.58	410.52	50.04	224.02	502.90	348.37	568.35	208.99	201.07

**Other Modes**

g_Walk,mi, Effective Walk Time [s]	-6.0		8.0		8.0		8.0	
M_corner, Corner Circulation Area [ft <sup>2</sup> /ped]	0.00		0.00		0.00		0.00	
M_CW, Crosswalk Circulation Area [ft <sup>2</sup> /ped]	0.00		0.00		0.00		0.00	
d_p, Pedestrian Delay [s]	62.36		48.49		48.49		48.49	
I_p,int, Pedestrian LOS Score for Intersectio	3.379		3.309		3.195		3.140	
Crosswalk LOS	C		C		C		C	
s_b, Saturation Flow Rate of the bicycle lane	2000		2000		2000		2000	
c_b, Capacity of the bicycle lane [bicycles/h]	623		623		623		623	
d_b, Bicycle Delay [s]	26.67		26.65		26.67		26.65	
I_b,int, Bicycle LOS Score for Intersection	3.083		2.115		2.753		2.395	
Bicycle LOS	C		B		C		B	

**Sequence**

Ring 1	1	2	3	4	-	-	-	-	-	-	-	-	-	-	-
Ring 2	5	6	7	8	-	-	-	-	-	-	-	-	-	-	-
Ring 3	-	-	-	-	-	-	-	-	-	-	-	-	-	-	-
Ring 4	-	-	-	-	-	-	-	-	-	-	-	-	-	-	-



**Intersection Level Of Service Report**  
**Intersection 4: Tassajara Road & I-580 WB Ramps**

Control Type:	Signalized	Delay (sec / veh):	11.5
Analysis Method:	HCM 7th Edition	Level Of Service:	B
Analysis Period:	15 minutes	Volume to Capacity (v/c):	0.674

**Intersection Setup**

Name	Tassajara Road		Tassajara Road		I-580 WB Ramps	
Approach	Northbound		Southbound		Westbound	
Lane Configuration	↑↑		↑↑↑		←←←→→	
Turning Movement	Thru	Right	Left	Thru	Left	Right
Lane Width [ft]	12.00	12.00	12.00	12.00	12.00	12.00
No. of Lanes in Entry Pocket	0	0	0	0	1	1
Entry Pocket Length [ft]	100.00	100.00	100.00	100.00	100.00	100.00
No. of Lanes in Exit Pocket	0	1	0	0	0	0
Exit Pocket Length [ft]	0.00	49.21	0.00	0.00	0.00	0.00
Speed [mph]	30.00		30.00		30.00	
Grade [%]	0.00		0.00		0.00	
Curb Present	No		No		No	
Crosswalk	Yes		Yes		Yes	



**Volumes**

Name	Tassajara Road		Tassajara Road		I-580 WB Ramps	
Base Volume Input [veh/h]	1608	0	0	1419	489	245
Base Volume Adjustment Factor	1.0000	1.0000	1.0000	1.0000	1.0000	1.0000
Heavy Vehicles Percentage [%]	0.40	2.00	2.00	0.80	0.40	1.70
Proportion of CAVs [%]	0.00					
Growth Factor	1.0000	1.0000	1.0000	1.0000	1.0000	1.0000
In-Process Volume [veh/h]	0	0	0	0	0	0
Site-Generated Trips [veh/h]	0	0	0	0	0	0
Diverted Trips [veh/h]	0	0	0	0	0	0
Pass-by Trips [veh/h]	0	0	0	0	0	0
Existing Site Adjustment Volume [veh/h]	0	0	0	0	0	0
Other Volume [veh/h]	0	0	0	0	0	0
Right Turn on Red Volume [veh/h]	0	0	0	0	0	0
Total Hourly Volume [veh/h]	1608	0	0	1419	489	245
Peak Hour Factor	0.9600	1.0000	1.0000	0.9600	0.9600	0.9600
Other Adjustment Factor	1.0000	1.0000	1.0000	1.0000	1.0000	1.0000
Total 15-Minute Volume [veh/h]	419	0	0	370	127	64
Total Analysis Volume [veh/h]	1675	0	0	1478	509	255
Presence of On-Street Parking	No	No	No	No	No	No
On-Street Parking Maneuver Rate [/h]	0	0	0	0	0	0
Local Bus Stopping Rate [/h]	0	0	0	0	0	0
v_do, Outbound Pedestrian Volume crossing	0		0		0	
v_di, Inbound Pedestrian Volume crossing m	0		0		0	
v_co, Outbound Pedestrian Volume crossing	0		0		0	
v_ci, Inbound Pedestrian Volume crossing mi	0		0		0	
v_ab, Corner Pedestrian Volume [ped/h]	0		0		0	
Bicycle Volume [bicycles/h]	1		0		0	



**Intersection Settings**

Located in CBD	No
Signal Coordination Group	-
Cycle Length [s]	60
Active Pattern	Pattern 1
Coordination Type	Time of Day Pattern Coordinated
Actuation Type	Fully actuated
Offset [s]	29.0
Offset Reference	Beginning of First Yellow
Permissive Mode	SingleBand
Lost time [s]	6.00

**Phasing & Timing (Basic)**

Control Type	Permissive	Permissive	Permissive	Permissive	Permissive	Permissive
Signal Group	6	0	0	2	4	0
Auxiliary Signal Groups						
Maximum Green [s]	40	0	0	40	20	0
Amber [s]	4.9	0.0	0.0	4.9	4.4	0.0
All red [s]	1.0	0.0	0.0	1.0	1.0	0.0
Walk [s]	5	0	0	0	0	0
Pedestrian Clearance [s]	16	0	0	0	0	0
Delayed Vehicle Green [s]	0.0	0.0	0.0	0.0	0.0	0.0
Rest In Walk	No			No	No	
I1, Start-Up Lost Time [s]	2.0	0.0	0.0	2.0	2.0	0.0
I2, Clearance Lost Time [s]	3.9	0.0	0.0	3.9	3.4	0.0
Detector Location [ft]	0.0	0.0	0.0	0.0	0.0	0.0
Detector Length [ft]	20.0	0.0	0.0	20.0	20.0	0.0
I, Upstream Filtering Factor	1.00	1.00	1.00	1.00	1.00	1.00

**Phasing & Timing: Pattern 1**

Split [s]	36	0	0	36	24	0
Lead / Lag	-	-	-	-	Lead	-
Minimum Green [s]	7	0	0	7	4	0
Vehicle Extension [s]	3.0	0.0	0.0	3.0	2.0	0.0
Minimum Recall	No			No	No	
Maximum Recall	Yes			Yes	No	
Pedestrian Recall	Yes			No	No	

**Exclusive Pedestrian Phase**

Pedestrian Signal Group	0
Pedestrian Walk [s]	0
Pedestrian Clearance [s]	0





**Lane Group Calculations**

Lane Group	C	C	L	R
C, Cycle Length [s]	63	63	63	63
L, Total Lost Time per Cycle [s]	5.90	5.90	5.40	5.40
l1_p, Permitted Start-Up Lost Time [s]	0.00	0.00	0.00	0.00
l2, Clearance Lost Time [s]	3.90	3.90	3.40	3.40
g_i, Effective Green Time [s]	40	40	12	12
g / C, Green / Cycle	0.63	0.63	0.19	0.19
(v / s)_i Volume / Saturation Flow Rate	0.46	0.29	0.15	0.09
s, saturation flow rate [veh/h]	3606	5143	3503	2820
c, Capacity [veh/h]	2282	3254	660	532
d1, Uniform Delay [s]	7.96	5.98	24.35	22.88
k, delay calibration	0.50	0.50	0.04	0.04
l, Upstream Filtering Factor	1.00	1.00	1.00	1.00
d2, Incremental Delay [s]	2.14	0.46	0.73	0.25
d3, Initial Queue Delay [s]	0.00	0.00	0.00	0.00
Rp, platoon ratio	1.00	1.00	1.00	1.00
PF, progression factor	1.00	1.00	1.00	1.00

**Lane Group Results**

X, volume / capacity	0.73	0.45	0.77	0.48
d, Delay for Lane Group [s/veh]	10.10	6.44	25.08	23.13
Lane Group LOS	B	A	C	C
Critical Lane Group	Yes	No	Yes	No
50th-Percentile Queue Length [veh/ln]	6.23	2.59	3.45	1.61
50th-Percentile Queue Length [ft/ln]	155.76	64.82	86.28	40.29
95th-Percentile Queue Length [veh/ln]	10.32	4.67	6.21	2.90
95th-Percentile Queue Length [ft/ln]	258.10	116.68	155.31	72.53

**Movement, Approach, & Intersection Results**

d_M, Delay for Movement [s/veh]	10.10	0.00	0.00	6.44	25.08	23.13
Movement LOS	B			A	C	C
d_A, Approach Delay [s/veh]	10.10		6.44		24.43	
Approach LOS	B		A		C	
d_I, Intersection Delay [s/veh]	11.52					
Intersection LOS	B					
Intersection V/C	0.674					

**Emissions**

Vehicle Miles Traveled [mph]	282.05	303.18	41.16	20.62
Stops [stops/h]	710.18	443.35	393.42	183.71
Fuel consumption [US gal/h]	18.98	16.87	6.47	3.06
CO [g/h]	1326.54	1179.08	452.01	214.21
NOx [g/h]	258.10	229.41	87.95	41.68
VOC [g/h]	307.44	273.26	104.76	49.65

**Other Modes**

g_Walk,mi, Effective Walk Time [s]	18.6	18.6	9.0
M_corner, Corner Circulation Area [ft <sup>2</sup> /ped]	0.00	0.00	0.00
M_CW, Crosswalk Circulation Area [ft <sup>2</sup> /ped]	0.00	0.00	0.00
d_p, Pedestrian Delay [s]	15.72	15.72	23.22
I_p,int, Pedestrian LOS Score for Intersectio	2.982	2.932	2.432
Crosswalk LOS	C	C	B
s_b, Saturation Flow Rate of the bicycle lane	2000	2000	2000
c_b, Capacity of the bicycle lane [bicycles/h]	953	953	589
d_b, Bicycle Delay [s]	8.66	8.65	15.72
I_b,int, Bicycle LOS Score for Intersection	2.941	2.373	1.560
Bicycle LOS	C	B	A

**Sequence**

Ring 1	-	2	-	4	-	-	-	-	-	-	-	-	-	-	-	-
Ring 2	-	6	-	-	-	-	-	-	-	-	-	-	-	-	-	-
Ring 3	-	-	-	-	-	-	-	-	-	-	-	-	-	-	-	-
Ring 4	-	-	-	-	-	-	-	-	-	-	-	-	-	-	-	-



**Intersection Level Of Service Report**  
**Intersection 5: Santa Rita Rd & I-580 EB Ramps/Pimlico Dr**

Control Type:	Signalized	Delay (sec / veh):	35.0
Analysis Method:	HCM 7th Edition	Level Of Service:	D
Analysis Period:	15 minutes	Volume to Capacity (v/c):	0.849

**Intersection Setup**

Name	Santa Rita Road			Tassajara Road			I-580 EB Ramps			Pimlico Drive		
Approach	Northbound			Southbound			Eastbound			Westbound		
Lane Configuration	↑↑↑↑			↵↑↑			↵↑↑			↵↵↵↵		
Turning Movement	Left	Thru	Right	Left	Thru	Right	Left	Thru	Right	Left	Thru	Right
Lane Width [ft]	12.00	12.00	12.00	12.00	12.00	12.00	12.00	12.00	12.00	12.00	12.00	12.00
No. of Lanes in Entry Pocket	0	0	1	1	0	0	1	0	0	2	0	1
Entry Pocket Length [ft]	100.00	100.00	250.00	425.00	100.00	100.00	625.00	100.00	100.00	200.00	100.00	250.00
No. of Lanes in Exit Pocket	0	0	0	0	0	2	0	0	0	0	0	0
Exit Pocket Length [ft]	0.00	0.00	0.00	0.00	0.00	49.21	0.00	0.00	0.00	0.00	0.00	0.00
Speed [mph]	30.00			30.00			30.00			30.00		
Grade [%]	0.00			0.00			0.00			0.00		
Curb Present	No			No			No			No		
Crosswalk	Yes			No			Yes			Yes		



**Volumes**

Name	Santa Rita Road			Tassajara Road			I-580 EB Ramps			Pimlico Drive		
Base Volume Input [veh/h]	0	1839	85	262	1155	0	548	208	0	112	0	431
Base Volume Adjustment Factor	1.0000	1.0000	1.0000	1.0000	1.0000	1.0000	1.0000	1.0000	1.0000	1.0000	1.0000	1.0000
Heavy Vehicles Percentage [%]	2.00	0.30	1.20	0.40	0.40	2.00	1.20	0.50	2.00	0.00	2.00	0.00
Proportion of CAVs [%]	0.00											
Growth Factor	1.0000	1.0000	1.0000	1.0000	1.0000	1.0000	1.0000	1.0000	1.0000	1.0000	1.0000	1.0000
In-Process Volume [veh/h]	0	0	0	0	0	0	0	0	0	0	0	0
Site-Generated Trips [veh/h]	0	0	0	0	0	0	0	0	0	0	0	0
Diverted Trips [veh/h]	0	0	0	0	0	0	0	0	0	0	0	0
Pass-by Trips [veh/h]	0	0	0	0	0	0	0	0	0	0	0	0
Existing Site Adjustment Volume [veh/h]	0	0	0	0	0	0	0	0	0	0	0	0
Other Volume [veh/h]	0	0	0	0	0	0	0	0	0	0	0	0
Right Turn on Red Volume [veh/h]	0	0	0	0	0	0	0	0	0	0	0	0
Total Hourly Volume [veh/h]	0	1839	85	262	1155	0	548	208	0	112	0	431
Peak Hour Factor	1.0000	0.9600	0.9600	0.9600	0.9600	1.0000	0.9600	0.9600	1.0000	0.9600	1.0000	0.9600
Other Adjustment Factor	1.0000	1.0000	1.0000	1.0000	1.0000	1.0000	1.0000	1.0000	1.0000	1.0000	1.0000	1.0000
Total 15-Minute Volume [veh/h]	0	479	22	68	301	0	143	54	0	29	0	112
Total Analysis Volume [veh/h]	0	1916	89	273	1203	0	571	217	0	117	0	449
Presence of On-Street Parking	No		No	No		No	No		No	No		No
On-Street Parking Maneuver Rate [/h]	0	0	0	0	0	0	0	0	0	0	0	0
Local Bus Stopping Rate [/h]	0	0	0	0	0	0	0	0	0	0	0	0
v_do, Outbound Pedestrian Volume crossing	1			0			0			0		
v_di, Inbound Pedestrian Volume crossing m	0			0			1			0		
v_co, Outbound Pedestrian Volume crossing	0			2			3			1		
v_ci, Inbound Pedestrian Volume crossing mi	1			3			2			0		
v_ab, Corner Pedestrian Volume [ped/h]	0			0			0			0		
Bicycle Volume [bicycles/h]	1			0			0			0		



**Intersection Settings**

Located in CBD	No
Signal Coordination Group	-
Cycle Length [s]	120
Active Pattern	Pattern 1
Coordination Type	Time of Day Pattern Coordinated
Actuation Type	Fully actuated
Offset [s]	13.0
Offset Reference	Lead Green - Beginning of First Green
Permissive Mode	SingleBand
Lost time [s]	12.00

**Phasing & Timing (Basic)**

Control Type	Permiss	Permiss	Permiss	Protecte	Permiss	Permiss	Protecte	Permiss	Permiss	Permiss	Permiss	Overlap
Signal Group	0	6	0	5	2	0	3	8	0	7	0	4
Auxiliary Signal Groups												4,5
Maximum Green [s]	0	30	0	20	30	0	27	20	0	20	0	20
Amber [s]	0.0	4.4	0.0	3.0	4.4	0.0	4.4	4.4	0.0	3.5	0.0	3.5
All red [s]	0.0	1.0	0.0	1.0	1.0	0.0	1.0	1.0	0.0	1.0	0.0	1.0
Walk [s]	0	5	0	0	5	0	0	5	0	0	0	0
Pedestrian Clearance [s]	0	25	0	0	8	0	0	25	0	0	0	0
Delayed Vehicle Green [s]	0.0	0.0	0.0	0.0	0.0	0.0	0.0	0.0	0.0	0.0	0.0	0.0
Rest In Walk		No			No			No		No		
I1, Start-Up Lost Time [s]	0.0	2.0	0.0	2.0	2.0	0.0	2.0	2.0	0.0	2.0	0.0	2.0
I2, Clearance Lost Time [s]	0.0	3.4	0.0	2.0	3.4	0.0	3.4	3.4	0.0	2.5	0.0	2.5
Detector Location [ft]	0.0	0.0	0.0	0.0	0.0	0.0	0.0	0.0	0.0	0.0	0.0	0.0
Detector Length [ft]	0.0	0.0	0.0	0.0	0.0	0.0	0.0	0.0	0.0	0.0	0.0	0.0
I, Upstream Filtering Factor	1.00	1.00	1.00	1.00	1.00	1.00	1.00	1.00	1.00	1.00	1.00	1.00

**Phasing & Timing: Pattern 1**

Split [s]	0	40	0	28	68	0	32	36	0	16	0	20
Lead / Lag	-	-	-	Lead	-	-	Lead	-	-	Lead	-	-
Minimum Green [s]	0	7	0	5	7	0	5	5	0	5	0	5
Vehicle Extension [s]	0.0	3.0	0.0	3.0	3.0	0.0	3.0	2.0	0.0	3.0	0.0	2.0
Minimum Recall		No		No	No		No	No		No		No
Maximum Recall		Yes		No	Yes		No	No		No		No
Pedestrian Recall		No		No	Yes		No	No		No		No

**Exclusive Pedestrian Phase**

Pedestrian Signal Group	0
Pedestrian Walk [s]	0
Pedestrian Clearance [s]	0



**Lane Group Calculations**

Lane Group	C	C	L	C	L	C	L	R
C, Cycle Length [s]	120	120	120	120	120	120	120	120
L, Total Lost Time per Cycle [s]	5.40	5.40	4.00	5.40	5.40	5.40	4.50	4.00
l1_p, Permitted Start-Up Lost Time [s]	0.00	0.00	0.00	0.00	0.00	0.00	0.00	0.00
l2, Clearance Lost Time [s]	3.40	3.40	2.00	3.40	3.40	3.40	2.50	0.00
g_i, Effective Green Time [s]	51	51	20	74	22	24	6	32
g / C, Green / Cycle	0.42	0.42	0.17	0.62	0.18	0.20	0.05	0.27
(v / s)_i Volume / Saturation Flow Rate	0.34	0.27	0.15	0.33	0.16	0.11	0.03	0.16
s, saturation flow rate [veh/h]	4379	1830	1804	3606	3481	1892	3514	2859
c, Capacity [veh/h]	1847	772	298	2237	641	382	177	774
d1, Uniform Delay [s]	30.52	27.60	49.22	12.96	47.74	43.16	55.92	37.83
k, delay calibration	0.50	0.50	0.36	0.50	0.11	0.12	0.11	0.04
l, Upstream Filtering Factor	1.00	1.00	1.00	1.00	1.00	1.00	1.00	1.00
d2, Incremental Delay [s]	4.07	4.21	27.59	0.93	4.54	1.49	4.18	0.26
d3, Initial Queue Delay [s]	0.00	0.00	0.00	0.00	0.00	0.00	0.00	0.00
Rp, platoon ratio	1.00	1.00	1.00	1.00	1.00	1.00	1.00	1.00
PF, progression factor	1.00	1.00	1.00	1.00	1.00	1.00	1.00	1.00

**Lane Group Results**

X, volume / capacity	0.81	0.65	0.92	0.54	0.89	0.57	0.66	0.58
d, Delay for Lane Group [s/veh]	34.59	31.81	76.81	13.89	52.28	44.65	60.11	38.09
Lane Group LOS	C	C	E	B	D	D	E	D
Critical Lane Group	Yes	No	Yes	No	Yes	No	No	Yes
50th-Percentile Queue Length [veh/ln]	13.21	12.22	10.30	9.10	8.70	5.97	1.84	5.73
50th-Percentile Queue Length [ft/ln]	330.22	305.45	257.53	227.62	217.53	149.21	46.08	143.26
95th-Percentile Queue Length [veh/ln]	19.17	17.95	15.56	14.05	13.54	9.97	3.32	9.66
95th-Percentile Queue Length [ft/ln]	479.23	448.76	389.12	351.33	338.47	249.37	82.94	241.40



**Movement, Approach, & Intersection Results**

d_M, Delay for Movement [s/veh]	0.00	33.99	31.81	76.81	13.89	0.00	52.28	44.65	0.00	60.11	0.00	38.09
Movement LOS		C	C	E	B		D	D		E		D
d_A, Approach Delay [s/veh]	33.89			25.53			50.18			42.64		
Approach LOS	C			C			D			D		
d_I, Intersection Delay [s/veh]	35.02											
Intersection LOS	D											
Intersection V/C	0.849											

**Emissions**

Vehicle Miles Traveled [mph]	148.31	49.44	45.97	202.57	79.23	30.11	9.99	38.32
Stops [stops/h]	1189.35	366.71	309.18	546.54	522.31	179.13	110.64	343.98
Fuel consumption [US gal/h]	23.26	7.31	7.87	14.76	12.22	4.20	2.45	6.96
CO [g/h]	1625.86	510.64	549.92	1031.65	854.29	293.63	171.49	486.39
NOx [g/h]	316.33	99.35	106.99	200.72	166.21	57.13	33.37	94.63
VOC [g/h]	376.81	118.35	127.45	239.10	197.99	68.05	39.74	112.73

**Other Modes**

g_Walk,mi, Effective Walk Time [s]	9.0		0.0		9.0		9.0
M_corner, Corner Circulation Area [ft <sup>2</sup> /ped]	0.00		0.00		0.00		0.00
M_CW, Crosswalk Circulation Area [ft <sup>2</sup> /ped]	6543.07		0.00		0.00		0.00
d_p, Pedestrian Delay [s]	51.31		0.00		51.31		51.31
I_p,int, Pedestrian LOS Score for Intersectio	3.008		0.000		2.338		2.538
Crosswalk LOS	C		F		B		B
s_b, Saturation Flow Rate of the bicycle lane	2000		2000		2000		2000
c_b, Capacity of the bicycle lane [bicycles/h]	577		1044		510		192
d_b, Bicycle Delay [s]	30.38		13.71		33.28		49.02
I_b,int, Bicycle LOS Score for Intersection	2.387		2.777		2.860		1.560
Bicycle LOS	B		C		C		A

**Sequence**

Ring 1	-	2	3	4	-	-	-	-	-	-	-	-	-	-	-
Ring 2	5	6	7	8	-	-	-	-	-	-	-	-	-	-	-
Ring 3	-	-	-	-	-	-	-	-	-	-	-	-	-	-	-
Ring 4	-	-	-	-	-	-	-	-	-	-	-	-	-	-	-



**Intersection Level Of Service Report**  
**Intersection 6: Tassajara Road & Fallon Road**

Control Type:	Signalized	Delay (sec / veh):	15.6
Analysis Method:	HCM 7th Edition	Level Of Service:	B
Analysis Period:	15 minutes	Volume to Capacity (v/c):	0.426

**Intersection Setup**

Name	Fallon Road			Fallon Road			Tassajara Road			Syrah Drive		
Approach	Northbound			Southbound			Eastbound			Westbound		
Lane Configuration												
Turning Movement	Left	Thru	Right	Left	Thru	Right	Left	Thru	Right	Left	Thru	Right
Lane Width [ft]	12.00	12.00	12.00	12.00	12.00	12.00	12.00	12.00	12.00	12.00	12.00	12.00
No. of Lanes in Entry Pocket	1	0	1	1	0	2	1	0	1	1	0	1
Entry Pocket Length [ft]	175.00	100.00	175.00	175.00	100.00	225.00	475.00	100.00	175.00	100.00	100.00	100.00
No. of Lanes in Exit Pocket	0	0	0	0	0	0	0	0	0	0	0	0
Exit Pocket Length [ft]	0.00	0.00	0.00	0.00	0.00	0.00	0.00	0.00	0.00	0.00	0.00	0.00
Speed [mph]	30.00			30.00			30.00			30.00		
Grade [%]	0.00			0.00			0.00			0.00		
Curb Present	No			No			No			No		
Crosswalk	Yes			Yes			Yes			Yes		





**Volumes**

Name	Fallon Road			Fallon Road			Tassajara Road			Syrah Drive		
Base Volume Input [veh/h]	60	318	21	5	317	348	459	26	65	4	17	6
Base Volume Adjustment Factor	1.0000	1.0000	1.0000	1.0000	1.0000	1.0000	1.0000	1.0000	1.0000	1.0000	1.0000	1.0000
Heavy Vehicles Percentage [%]	0.00	0.00	4.80	0.00	2.50	0.30	0.20	0.00	0.00	0.00	0.00	20.00
Proportion of CAVs [%]	0.00											
Growth Factor	1.0000	1.0000	1.0000	1.0000	1.0000	1.0000	1.0000	1.0000	1.0000	1.0000	1.0000	1.0000
In-Process Volume [veh/h]	0	0	0	0	0	0	0	0	0	0	0	0
Site-Generated Trips [veh/h]	0	0	0	0	0	0	0	0	0	0	0	0
Diverted Trips [veh/h]	0	0	0	0	0	0	0	0	0	0	0	0
Pass-by Trips [veh/h]	0	0	0	0	0	0	0	0	0	0	0	0
Existing Site Adjustment Volume [veh/h]	0	0	0	0	0	0	0	0	0	0	0	0
Other Volume [veh/h]	0	0	0	0	0	0	0	0	0	0	0	0
Right Turn on Red Volume [veh/h]	0	0	0	0	0	0	0	0	0	0	0	0
Total Hourly Volume [veh/h]	60	318	21	5	317	348	459	26	65	4	17	6
Peak Hour Factor	0.9200	0.9200	0.9200	0.9200	0.9200	0.9200	0.9200	0.9200	0.9200	0.9200	0.9200	0.9200
Other Adjustment Factor	1.0000	1.0000	1.0000	1.0000	1.0000	1.0000	1.0000	1.0000	1.0000	1.0000	1.0000	1.0000
Total 15-Minute Volume [veh/h]	16	86	6	1	86	95	125	7	18	1	5	2
Total Analysis Volume [veh/h]	65	346	23	5	345	378	499	28	71	4	18	7
Presence of On-Street Parking	No		No	No		No	No		No	No		No
On-Street Parking Maneuver Rate [/h]	0	0	0	0	0	0	0	0	0	0	0	0
Local Bus Stopping Rate [/h]	0	0	0	0	0	0	0	0	0	0	0	0
v_do, Outbound Pedestrian Volume crossing	0			0			0			0		
v_di, Inbound Pedestrian Volume crossing m	0			0			0			0		
v_co, Outbound Pedestrian Volume crossing	0			0			0			0		
v_ci, Inbound Pedestrian Volume crossing mi	0			0			0			0		
v_ab, Corner Pedestrian Volume [ped/h]	0			0			0			0		
Bicycle Volume [bicycles/h]	0			0			0			0		



**Intersection Settings**

Located in CBD	No
Signal Coordination Group	-
Cycle Length [s]	90
Active Pattern	Free Running (No Pattern)
Coordination Type	<i>Free Running</i>
Actuation Type	<i>Fully actuated</i>
Offset [s]	0.0
Offset Reference	Lead Green - Beginning of First Green
Permissive Mode	SingleBand
Lost time [s]	12.00

**Phasing & Timing (Basic)**

Control Type	Protecte	Permiss	Permiss	Protecte	Permiss	Permiss	Protecte	Permiss	Permiss	Protecte	Permiss	Permiss
Signal Group	3	8	0	7	4	0	5	2	0	1	6	0
Auxiliary Signal Groups												
Maximum Green [s]	25	50	0	25	50	0	35	30	0	20	30	0
Amber [s]	3.5	4.8	0.0	3.5	4.8	0.0	3.5	5.0	0.0	3.0	3.6	0.0
All red [s]	1.0	1.0	0.0	1.0	1.0	0.0	1.0	1.0	0.0	1.0	1.0	0.0
Walk [s]	0	4	0	0	0	0	0	4	0	0	3	0
Pedestrian Clearance [s]	0	25	0	0	0	0	0	28	0	0	36	0
Delayed Vehicle Green [s]	0.0	0.0	0.0	0.0	0.0	0.0	0.0	0.0	0.0	0.0	0.0	0.0
Rest In Walk		No			No			No			No	
I1, Start-Up Lost Time [s]	2.0	2.0	0.0	2.0	2.0	0.0	2.0	2.0	0.0	2.0	2.0	0.0
I2, Clearance Lost Time [s]	2.0	2.0	0.0	2.0	2.0	0.0	2.0	2.0	0.0	2.0	2.0	0.0
Detector Location [ft]	0.0	0.0	0.0	0.0	0.0	0.0	0.0	0.0	0.0	0.0	0.0	0.0
Detector Length [ft]	0.0	0.0	0.0	0.0	0.0	0.0	0.0	0.0	0.0	0.0	0.0	0.0
I, Upstream Filtering Factor	1.00	1.00	1.00	1.00	1.00	1.00	1.00	1.00	1.00	1.00	1.00	1.00

**Phasing & Timing: Free Running (No Pattern)**

Split [s]	0	0	0	0	0	0	0	0	0	0	0	0
Lead / Lag	Lead	-	-	Lead	-	-	Lead	-	-	Lead	-	-
Minimum Green [s]	9	10	0	9	10	0	11	8	0	12	9	0
Vehicle Extension [s]	3.0	3.0	0.0	3.0	3.0	0.0	3.0	3.0	0.0	3.0	3.0	0.0
Minimum Recall	No	No		No	No		Yes	No		No	No	
Maximum Recall	No	No		No	No		No	No		No	No	
Pedestrian Recall	No	No		No	No		No	No		No	No	

**Exclusive Pedestrian Phase**

Pedestrian Signal Group	0
Pedestrian Walk [s]	0
Pedestrian Clearance [s]	0



**Lane Group Calculations**

Lane Group	L	C	R	L	C	R	L	C	R	L	C	R
C, Cycle Length [s]	48	48	48	48	48	48	48	48	48	48	48	48
L, Total Lost Time per Cycle [s]	4.00	4.00	4.00	4.00	4.00	4.00	4.00	4.00	4.00	4.00	4.00	4.00
l1_p, Permitted Start-Up Lost Time [s]	0.00	0.00	0.00	0.00	0.00	0.00	0.00	0.00	0.00	0.00	0.00	0.00
l2, Clearance Lost Time [s]	2.00	2.00	2.00	2.00	2.00	2.00	2.00	2.00	2.00	2.00	2.00	2.00
g_i, Effective Green Time [s]	6	17	17	1	12	12	12	14	14	1	3	3
g / C, Green / Cycle	0.12	0.34	0.34	0.02	0.24	0.24	0.24	0.29	0.29	0.01	0.07	0.07
(v / s)_i Volume / Saturation Flow Rate	0.04	0.10	0.01	0.00	0.10	0.13	0.14	0.01	0.04	0.00	0.01	0.01
s, saturation flow rate [veh/h]	1810	3618	1554	1810	3546	2852	3509	1900	1615	1810	1900	1360
c, Capacity [veh/h]	218	1238	532	42	867	698	834	553	470	25	127	91
d1, Uniform Delay [s]	19.45	11.60	10.65	23.21	15.33	15.95	16.42	12.36	12.74	23.65	21.31	21.22
k, delay calibration	0.11	0.11	0.11	0.11	0.11	0.11	0.11	0.11	0.11	0.11	0.11	0.11
l, Upstream Filtering Factor	1.00	1.00	1.00	1.00	1.00	1.00	1.00	1.00	1.00	1.00	1.00	1.00
d2, Incremental Delay [s]	0.75	0.12	0.03	1.27	0.30	0.66	0.69	0.04	0.15	3.06	0.50	0.35
d3, Initial Queue Delay [s]	0.00	0.00	0.00	0.00	0.00	0.00	0.00	0.00	0.00	0.00	0.00	0.00
Rp, platoon ratio	1.00	1.00	1.00	1.00	1.00	1.00	1.00	1.00	1.00	1.00	1.00	1.00
PF, progression factor	1.00	1.00	1.00	1.00	1.00	1.00	1.00	1.00	1.00	1.00	1.00	1.00

**Lane Group Results**

X, volume / capacity	0.30	0.28	0.04	0.12	0.40	0.54	0.60	0.05	0.15	0.16	0.14	0.08
d, Delay for Lane Group [s/veh]	20.20	11.72	10.68	24.48	15.62	16.61	17.11	12.40	12.89	26.71	21.81	21.57
Lane Group LOS	C	B	B	C	B	B	B	B	B	C	C	C
Critical Lane Group	Yes	No	No	No	No	Yes	Yes	No	No	No	Yes	No
50th-Percentile Queue Length [veh/ln]	0.65	1.16	0.14	0.07	1.42	1.65	2.22	0.19	0.51	0.06	0.19	0.08
50th-Percentile Queue Length [ft/ln]	16.20	29.00	3.60	1.65	35.58	41.14	55.44	4.86	12.80	1.56	4.83	1.92
95th-Percentile Queue Length [veh/ln]	1.17	2.09	0.26	0.12	2.56	2.96	3.99	0.35	0.92	0.11	0.35	0.14
95th-Percentile Queue Length [ft/ln]	29.17	52.21	6.48	2.97	64.04	74.05	99.80	8.75	23.04	2.81	8.69	3.46



**Movement, Approach, & Intersection Results**

d_M, Delay for Movement [s/veh]	20.20	11.72	10.68	24.48	15.62	16.61	17.11	12.40	12.89	26.71	21.81	21.57
Movement LOS	C	B	B	C	B	B	B	B	B	C	C	C
d_A, Approach Delay [s/veh]	12.94			16.19			16.39			22.43		
Approach LOS	B			B			B			C		
d_I, Intersection Delay [s/veh]	15.57											
Intersection LOS	B											
Intersection V/C	0.426											

**Emissions**

Vehicle Miles Traveled [mph]	6.19	32.97	2.19	0.54	37.45	41.03	64.35	3.61	9.16	0.14	0.65	0.25
Stops [stops/h]	48.26	172.76	10.71	4.92	211.91	245.05	330.25	14.47	38.12	4.65	14.39	5.73
Fuel consumption [US gal/h]	0.79	3.14	0.20	0.07	3.81	4.32	6.21	0.30	0.77	0.05	0.19	0.07
CO [g/h]	55.14	219.30	13.94	5.20	266.27	302.00	434.18	20.92	54.09	3.73	13.00	5.08
NOx [g/h]	10.73	42.67	2.71	1.01	51.81	58.76	84.47	4.07	10.52	0.73	2.53	0.99
VOC [g/h]	12.78	50.82	3.23	1.21	61.71	69.99	100.62	4.85	12.53	0.86	3.01	1.18

**Other Modes**

g_Walk,mi, Effective Walk Time [s]	8.0			7.0			-5.8			8.0		
M_corner, Corner Circulation Area [ft <sup>2</sup> /ped]	0.00			0.00			0.00			0.00		
M_CW, Crosswalk Circulation Area [ft <sup>2</sup> /ped]	0.00			0.00			0.00			0.00		
d_p, Pedestrian Delay [s]	16.84			17.68			30.32			16.84		
I_p,int, Pedestrian LOS Score for Intersectio	2.562			2.786			2.619			2.122		
Crosswalk LOS	B			C			B			B		
s_b, Saturation Flow Rate of the bicycle lane	2000			2000			2000			2000		
c_b, Capacity of the bicycle lane [bicycles/h]	2068			2068			1241			1241		
d_b, Bicycle Delay [s]	0.03			0.03			3.48			3.48		
I_b,int, Bicycle LOS Score for Intersection	1.918			2.160			2.546			1.607		
Bicycle LOS	A			B			B			A		

**Sequence**

Ring 1	1	2	3	4	-	-	-	-	-	-	-	-	-	-	-
Ring 2	5	6	7	8	-	-	-	-	-	-	-	-	-	-	-
Ring 3	-	-	-	-	-	-	-	-	-	-	-	-	-	-	-
Ring 4	-	-	-	-	-	-	-	-	-	-	-	-	-	-	-



**Intersection Level Of Service Report**  
**Intersection 7: Fallon Road & Positano Parkway**

Control Type:	Signalized	Delay (sec / veh):	10.7
Analysis Method:	HCM 7th Edition	Level Of Service:	B
Analysis Period:	15 minutes	Volume to Capacity (v/c):	0.555

**Intersection Setup**

Name	Fallon Road		Fallon Road		Positano Parkway	
Approach	Northbound		Southbound		Westbound	
Lane Configuration	↑↑↑↔		↔↑↑↑		↔↔↔	
Turning Movement	Thru	Right	Left	Thru	Left	Right
Lane Width [ft]	12.00	12.00	12.00	12.00	12.00	12.00
No. of Lanes in Entry Pocket	0	1	1	0	1	1
Entry Pocket Length [ft]	100.00	225.00	325.00	100.00	375.00	425.00
No. of Lanes in Exit Pocket	0	0	0	0	0	0
Exit Pocket Length [ft]	0.00	0.00	0.00	0.00	0.00	0.00
Speed [mph]	30.00		30.00		30.00	
Grade [%]	0.00		0.00		0.00	
Curb Present	No		No		No	
Crosswalk	Yes		Yes		Yes	



**Volumes**

Name	Fallon Road		Fallon Road		Positano Parkway	
Base Volume Input [veh/h]	503	349	175	477	319	102
Base Volume Adjustment Factor	1.0000	1.0000	1.0000	1.0000	1.0000	1.0000
Heavy Vehicles Percentage [%]	0.20	0.00	0.00	1.50	0.00	0.00
Proportion of CAVs [%]	0.00					
Growth Factor	1.0000	1.0000	1.0000	1.0000	1.0000	1.0000
In-Process Volume [veh/h]	0	0	0	0	0	0
Site-Generated Trips [veh/h]	0	0	0	0	0	0
Diverted Trips [veh/h]	0	0	0	0	0	0
Pass-by Trips [veh/h]	0	0	0	0	0	0
Existing Site Adjustment Volume [veh/h]	0	0	0	0	0	0
Other Volume [veh/h]	0	0	0	0	0	0
Right Turn on Red Volume [veh/h]	0	0	0	0	0	0
Total Hourly Volume [veh/h]	503	349	175	477	319	102
Peak Hour Factor	0.9300	0.9300	0.9300	0.9300	0.9300	0.9300
Other Adjustment Factor	1.0000	1.0000	1.0000	1.0000	1.0000	1.0000
Total 15-Minute Volume [veh/h]	135	94	47	128	86	27
Total Analysis Volume [veh/h]	541	375	188	513	343	110
Presence of On-Street Parking	No	No	No	No	No	No
On-Street Parking Maneuver Rate [/h]	0	0	0	0	0	0
Local Bus Stopping Rate [/h]	0	0	0	0	0	0
v_do, Outbound Pedestrian Volume crossing	0		1		0	
v_di, Inbound Pedestrian Volume crossing m	0		0		1	
v_co, Outbound Pedestrian Volume crossing	0		0		1	
v_ci, Inbound Pedestrian Volume crossing mi	1		0		0	
v_ab, Corner Pedestrian Volume [ped/h]	0		0		0	
Bicycle Volume [bicycles/h]	0		0		0	



**Intersection Settings**

Located in CBD	No
Signal Coordination Group	-
Cycle Length [s]	90
Active Pattern	Free Running (No Pattern)
Coordination Type	<i>Free Running</i>
Actuation Type	<i>Fully actuated</i>
Offset [s]	0.0
Offset Reference	Lead Green - Beginning of First Green
Permissive Mode	SingleBand
Lost time [s]	9.00

**Phasing & Timing (Basic)**

Control Type	Permissive	Permissive	Protected	Permissive	Permissive	Permissive
Signal Group	4	0	7	8	6	0
Auxiliary Signal Groups						
Maximum Green [s]	30	0	20	30	24	0
Amber [s]	4.3	0.0	3.5	4.3	4.0	0.0
All red [s]	1.0	0.0	1.0	1.0	1.0	0.0
Walk [s]	0	0	0	4	4	0
Pedestrian Clearance [s]	0	0	0	20	34	0
Delayed Vehicle Green [s]	0.0	0.0	0.0	0.0	0.0	0.0
Rest In Walk	No			No	No	
I1, Start-Up Lost Time [s]	2.0	0.0	2.0	2.0	2.0	0.0
I2, Clearance Lost Time [s]	2.0	0.0	2.0	2.0	2.0	0.0
Detector Location [ft]	0.0	0.0	0.0	0.0	0.0	0.0
Detector Length [ft]	20.0	0.0	20.0	20.0	20.0	0.0
I, Upstream Filtering Factor	1.00	1.00	1.00	1.00	1.00	1.00

**Phasing & Timing: Free Running (No Pattern)**

Split [s]	14	0	9	14	9	0
Lead / Lag	-	-	Lead	-	Lead	-
Minimum Green [s]	10	0	5	10	5	0
Vehicle Extension [s]	3.0	0.0	3.0	3.0	3.0	0.0
Minimum Recall	Yes		No	Yes	No	
Maximum Recall	No		No	No	No	
Pedestrian Recall	No		No	No	No	

**Exclusive Pedestrian Phase**

Pedestrian Signal Group	0
Pedestrian Walk [s]	0
Pedestrian Clearance [s]	0



**Lane Group Calculations**

Lane Group	C	R	L	C	L	R
C, Cycle Length [s]	41	41	41	41	41	41
L, Total Lost Time per Cycle [s]	4.00	4.00	4.00	4.00	4.00	4.00
l1_p, Permitted Start-Up Lost Time [s]	0.00	0.00	0.00	0.00	0.00	0.00
l2, Clearance Lost Time [s]	2.00	2.00	2.00	2.00	2.00	2.00
g_i, Effective Green Time [s]	15	15	6	25	8	8
g / C, Green / Cycle	0.36	0.36	0.15	0.61	0.20	0.20
(v / s)_i Volume / Saturation Flow Rate	0.10	0.23	0.10	0.10	0.10	0.07
s, saturation flow rate [veh/h]	5167	1615	1810	5114	3514	1613
c, Capacity [veh/h]	1842	576	276	3098	704	323
d1, Uniform Delay [s]	9.54	11.12	16.53	3.56	14.61	14.15
k, delay calibration	0.11	0.11	0.11	0.11	0.11	0.11
l, Upstream Filtering Factor	1.00	1.00	1.00	1.00	1.00	1.00
d2, Incremental Delay [s]	0.09	1.25	2.97	0.02	0.52	0.62
d3, Initial Queue Delay [s]	0.00	0.00	0.00	0.00	0.00	0.00
Rp, platoon ratio	1.00	1.00	1.00	1.00	1.00	1.00
PF, progression factor	1.00	1.00	1.00	1.00	1.00	1.00

**Lane Group Results**

X, volume / capacity	0.29	0.65	0.68	0.17	0.49	0.34
d, Delay for Lane Group [s/veh]	9.63	12.38	19.50	3.59	15.14	14.77
Lane Group LOS	A	B	B	A	B	B
Critical Lane Group	No	Yes	Yes	No	Yes	No
50th-Percentile Queue Length [veh/ln]	0.92	2.38	1.66	0.32	1.24	0.79
50th-Percentile Queue Length [ft/ln]	22.89	59.62	41.38	7.90	31.00	19.85
95th-Percentile Queue Length [veh/ln]	1.65	4.29	2.98	0.57	2.23	1.43
95th-Percentile Queue Length [ft/ln]	41.21	107.31	74.48	14.22	55.81	35.73



**Movement, Approach, & Intersection Results**

d_M, Delay for Movement [s/veh]	9.63	12.38	19.50	3.59	15.14	14.77
Movement LOS	A	B	B	A	B	B
d_A, Approach Delay [s/veh]	10.75		7.86		15.05	
Approach LOS	B		A		B	
d_I, Intersection Delay [s/veh]	10.71					
Intersection LOS	B					
Intersection V/C	0.555					

**Emissions**

Vehicle Miles Traveled [mph]	136.07	94.32	16.49	45.01	41.13	13.19
Stops [stops/h]	240.43	208.68	144.84	82.97	217.05	69.49
Fuel consumption [US gal/h]	7.99	5.98	2.23	2.69	3.95	1.26
CO [g/h]	558.48	418.01	155.56	187.73	276.05	87.91
NOx [g/h]	108.66	81.33	30.27	36.53	53.71	17.10
VOC [g/h]	129.43	96.88	36.05	43.51	63.98	20.37

**Other Modes**

g_Walk,mi, Effective Walk Time [s]	8.0		8.0		8.7	
M_corner, Corner Circulation Area [ft <sup>2</sup> /ped]	0.00		0.00		0.00	
M_CW, Crosswalk Circulation Area [ft <sup>2</sup> /ped]	0.00		0.00		0.00	
d_p, Pedestrian Delay [s]	13.35		13.35		12.79	
I_p,int, Pedestrian LOS Score for Intersectio	2.802		2.743		2.338	
Crosswalk LOS	C		B		B	
s_b, Saturation Flow Rate of the bicycle lane	2000		2000		2000	
c_b, Capacity of the bicycle lane [bicycles/h]	1459		1459		1167	
d_b, Bicycle Delay [s]	1.51		1.51		3.57	
I_b,int, Bicycle LOS Score for Intersection	2.063		1.945		1.560	
Bicycle LOS	B		A		A	

**Sequence**

Ring 1	-	-	-	8	-	-	-	-	-	-	-	-	-	-	-	-
Ring 2	-	6	7	4	-	-	-	-	-	-	-	-	-	-	-	-
Ring 3	-	-	-	-	-	-	-	-	-	-	-	-	-	-	-	-
Ring 4	-	-	-	-	-	-	-	-	-	-	-	-	-	-	-	-

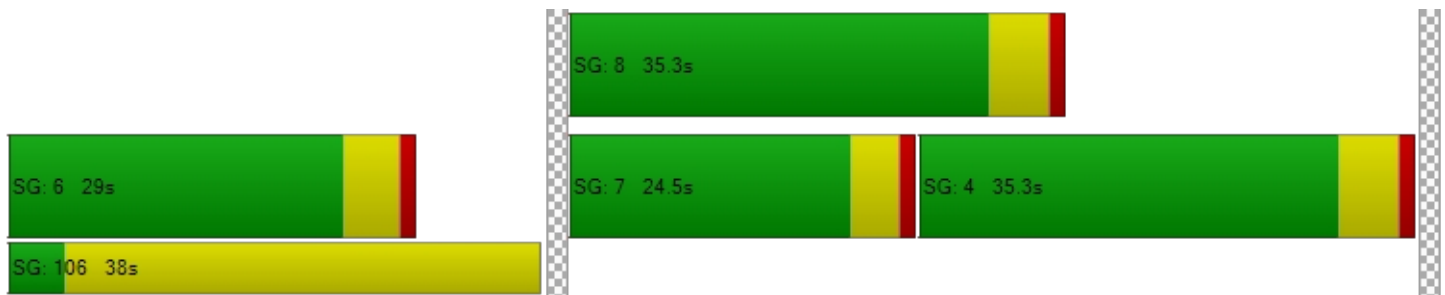

**Intersection Level Of Service Report**  
**Intersection 8: Fallon Road & Central Parkway**

Control Type:	Signalized	Delay (sec / veh):	21.2
Analysis Method:	HCM 7th Edition	Level Of Service:	C
Analysis Period:	15 minutes	Volume to Capacity (v/c):	0.398

**Intersection Setup**

Name	Fallon Road			Fallon Road			Central Parkway			Central Parkway		
Approach	Northbound			Southbound			Eastbound			Westbound		
Lane Configuration	⇐⇐⇐			⇐⇐⇐			⇐⇐⇐			⇐⇐⇐		
Turning Movement	Left	Thru	Right	Left	Thru	Right	Left	Thru	Right	Left	Thru	Right
Lane Width [ft]	12.00	12.00	12.00	12.00	12.00	12.00	12.00	12.00	12.00	12.00	12.00	12.00
No. of Lanes in Entry Pocket	2	0	1	1	0	1	2	0	2	2	0	1
Entry Pocket Length [ft]	300.00	100.00	255.00	295.00	100.00	245.00	350.00	100.00	230.00	250.00	100.00	250.00
No. of Lanes in Exit Pocket	0	0	1	0	0	2	0	0	0	0	0	0
Exit Pocket Length [ft]	0.00	0.00	250.00	0.00	0.00	500.00	0.00	0.00	0.00	0.00	0.00	0.00
Speed [mph]	40.00			30.00			25.00			30.00		
Grade [%]	0.00			0.00			0.00			0.00		
Curb Present	Yes			Yes			Yes			Yes		
Crosswalk	Yes			Yes			Yes			Yes		



**Volumes**

Name	Fallon Road			Fallon Road			Central Parkway			Central Parkway		
Base Volume Input [veh/h]	134	846	167	32	838	111	102	48	155	175	40	35
Base Volume Adjustment Factor	1.0000	1.0000	1.0000	1.0000	1.0000	1.0000	1.0000	1.0000	1.0000	1.0000	1.0000	1.0000
Heavy Vehicles Percentage [%]	0.70	0.10	0.00	0.00	0.40	0.00	0.00	0.00	0.00	0.00	0.00	0.00
Proportion of CAVs [%]	0.00											
Growth Factor	1.0000	1.0000	1.0000	1.0000	1.0000	1.0000	1.0000	1.0000	1.0000	1.0000	1.0000	1.0000
In-Process Volume [veh/h]	0	0	0	0	0	0	0	0	0	0	0	0
Site-Generated Trips [veh/h]	0	0	0	0	0	0	0	0	0	0	0	0
Diverted Trips [veh/h]	0	0	0	0	0	0	0	0	0	0	0	0
Pass-by Trips [veh/h]	0	0	0	0	0	0	0	0	0	0	0	0
Existing Site Adjustment Volume [veh/h]	0	0	0	0	0	0	0	0	0	0	0	0
Other Volume [veh/h]	0	0	0	0	0	0	0	0	0	0	0	0
Right Turn on Red Volume [veh/h]	0	0	0	0	0	0	0	0	0	0	0	0
Total Hourly Volume [veh/h]	134	846	167	32	838	111	102	48	155	175	40	35
Peak Hour Factor	0.9200	0.9200	0.9200	0.9200	0.9200	0.9200	0.9200	0.9200	0.9200	0.9200	0.9200	0.9200
Other Adjustment Factor	1.0000	1.0000	1.0000	1.0000	1.0000	1.0000	1.0000	1.0000	1.0000	1.0000	1.0000	1.0000
Total 15-Minute Volume [veh/h]	36	230	45	9	228	30	28	13	42	48	11	10
Total Analysis Volume [veh/h]	146	920	182	35	911	121	111	52	168	190	43	38
Presence of On-Street Parking	No		No	No		No	No		No	No		No
On-Street Parking Maneuver Rate [/h]	0	0	0	0	0	0	0	0	0	0	0	0
Local Bus Stopping Rate [/h]	0	0	0	0	0	0	0	0	0	0	0	0
v_do, Outbound Pedestrian Volume crossing	1			4			4			1		
v_di, Inbound Pedestrian Volume crossing m	1			4			4			1		
v_co, Outbound Pedestrian Volume crossing	2			6			1			5		
v_ci, Inbound Pedestrian Volume crossing mi	1			5			2			6		
v_ab, Corner Pedestrian Volume [ped/h]	0			0			0			0		
Bicycle Volume [bicycles/h]	0			1			0			0		



**Intersection Settings**

Located in CBD	No
Signal Coordination Group	-
Cycle Length [s]	90
Active Pattern	Free Running (No Pattern)
Coordination Type	Free Running
Actuation Type	Fully actuated
Offset [s]	0.0
Offset Reference	Lead Green - Beginning of First Green
Permissive Mode	SingleBand
Lost time [s]	12.00

**Phasing & Timing (Basic)**

Control Type	Protecte	Permiss	Permiss	Protecte	Permiss	Permiss	Protecte	Permiss	Permiss	Protecte	Permiss	Permiss
Signal Group	3	8	0	7	4	0	5	2	0	1	6	0
Auxiliary Signal Groups												
Maximum Green [s]	20	30	0	20	30	0	20	30	0	20	30	0
Amber [s]	3.5	4.3	0.0	3.0	4.3	0.0	3.0	4.0	0.0	3.0	4.0	0.0
All red [s]	1.0	1.0	0.0	1.0	1.0	0.0	1.0	1.0	0.0	1.0	1.0	0.0
Walk [s]	0	4	0	0	4	0	0	4	0	0	4	0
Pedestrian Clearance [s]	0	28	0	0	34	0	0	42	0	0	41	0
Delayed Vehicle Green [s]	0.0	0.0	0.0	0.0	0.0	0.0	0.0	0.0	0.0	0.0	0.0	0.0
Rest In Walk		No			No			No			No	
I1, Start-Up Lost Time [s]	2.0	2.0	0.0	2.0	2.0	0.0	2.0	2.0	0.0	2.0	2.0	0.0
I2, Clearance Lost Time [s]	2.0	2.0	0.0	2.0	2.0	0.0	2.0	2.0	0.0	2.0	2.0	0.0
Detector Location [ft]	0.0	0.0	0.0	0.0	0.0	0.0	0.0	0.0	0.0	0.0	0.0	0.0
Detector Length [ft]	20.0	20.0	0.0	20.0	20.0	0.0	20.0	20.0	0.0	20.0	20.0	0.0
I, Upstream Filtering Factor	1.00	1.00	1.00	1.00	1.00	1.00	1.00	1.00	1.00	1.00	1.00	1.00

**Phasing & Timing: Free Running (No Pattern)**

Split [s]	0	0	0	0	0	0	0	0	0	0	0	0
Lead / Lag	Lead	-	-	Lead	-	-	Lead	-	-	Lead	-	-
Minimum Green [s]	10	12	0	10	12	0	10	12	0	10	12	0
Vehicle Extension [s]	2.0	4.0	0.0	2.0	4.0	0.0	2.0	4.0	0.0	2.0	4.0	0.0
Minimum Recall	No	Yes		No	Yes		No	No		No	No	
Maximum Recall	No	No		No	No		No	No		No	No	
Pedestrian Recall	No	No		No	No		No	No		No	No	

**Exclusive Pedestrian Phase**

Pedestrian Signal Group	0
Pedestrian Walk [s]	0
Pedestrian Clearance [s]	0



**Lane Group Calculations**

Lane Group	L	C	R	L	C	R	L	C	R	L	C	R
C, Cycle Length [s]	71	71	71	71	71	71	71	71	71	71	71	71
L, Total Lost Time per Cycle [s]	4.00	4.00	4.00	4.00	4.00	4.00	4.00	4.00	4.00	4.00	4.00	4.00
l1_p, Permitted Start-Up Lost Time [s]	0.00	0.00	0.00	0.00	0.00	0.00	0.00	0.00	0.00	0.00	0.00	0.00
l2, Clearance Lost Time [s]	2.00	2.00	2.00	2.00	2.00	2.00	2.00	2.00	2.00	2.00	2.00	2.00
g_i, Effective Green Time [s]	10	27	27	5	22	22	9	14	14	10	15	15
g / C, Green / Cycle	0.14	0.37	0.37	0.07	0.30	0.30	0.12	0.19	0.19	0.14	0.21	0.21
(v / s)_i Volume / Saturation Flow Rate	0.04	0.18	0.11	0.02	0.18	0.08	0.03	0.03	0.06	0.05	0.02	0.02
s, saturation flow rate [veh/h]	3495	5172	1611	1810	5159	1582	3514	1900	2845	3514	1900	1589
c, Capacity [veh/h]	488	1931	601	128	1572	482	439	370	554	481	393	329
d1, Uniform Delay [s]	27.61	17.07	15.81	31.46	20.98	18.67	28.26	23.82	24.62	28.15	23.01	23.03
k, delay calibration	0.04	0.15	0.15	0.04	0.15	0.15	0.04	0.15	0.15	0.04	0.15	0.15
l, Upstream Filtering Factor	1.00	1.00	1.00	1.00	1.00	1.00	1.00	1.00	1.00	1.00	1.00	1.00
d2, Incremental Delay [s]	0.13	0.26	0.40	0.42	0.48	0.38	0.11	0.24	0.43	0.20	0.17	0.22
d3, Initial Queue Delay [s]	0.00	0.00	0.00	0.00	0.00	0.00	0.00	0.00	0.00	0.00	0.00	0.00
Rp, platoon ratio	1.00	1.00	1.00	1.00	1.00	1.00	1.00	1.00	1.00	1.00	1.00	1.00
PF, progression factor	1.00	1.00	1.00	1.00	1.00	1.00	1.00	1.00	1.00	1.00	1.00	1.00

**Lane Group Results**

X, volume / capacity	0.30	0.48	0.30	0.27	0.58	0.25	0.25	0.14	0.30	0.39	0.11	0.12
d, Delay for Lane Group [s/veh]	27.74	17.33	16.21	31.88	21.46	19.06	28.37	24.07	25.05	28.34	23.19	23.25
Lane Group LOS	C	B	B	C	C	B	C	C	C	C	C	C
Critical Lane Group	Yes	No	No	No	Yes	No	No	No	Yes	Yes	No	No
50th-Percentile Queue Length [veh/ln]	1.05	3.44	1.93	0.57	4.09	1.48	0.85	0.74	1.22	1.44	0.58	0.52
50th-Percentile Queue Length [ft/ln]	26.34	85.89	48.25	14.24	102.31	36.95	21.22	18.41	30.52	36.04	14.60	13.00
95th-Percentile Queue Length [veh/ln]	1.90	6.18	3.47	1.03	7.37	2.66	1.53	1.33	2.20	2.59	1.05	0.94
95th-Percentile Queue Length [ft/ln]	47.42	154.60	86.86	25.64	184.16	66.51	38.19	33.14	54.94	64.87	26.27	23.39



**Movement, Approach, & Intersection Results**

d_M, Delay for Movement [s/veh]	27.74	17.33	16.21	31.88	21.46	19.06	28.37	24.07	25.05	28.34	23.19	23.25
Movement LOS	C	B	B	C	C	B	C	C	C	C	C	C
d_A, Approach Delay [s/veh]	18.38			21.53			26.01			26.81		
Approach LOS	B			C			C			C		
d_I, Intersection Delay [s/veh]	21.18											
Intersection LOS	C											
Intersection V/C	0.398											

**Emissions**

Vehicle Miles Traveled [mph]	38.66	243.59	48.19	8.80	229.12	30.43	9.70	4.54	14.68	43.19	9.78	8.64
Stops [stops/h]	106.31	519.86	97.36	28.73	619.28	74.55	85.61	37.15	123.17	145.43	29.45	26.22
Fuel consumption [US gal/h]	3.25	17.08	3.28	0.75	16.83	2.13	1.41	0.60	1.99	3.68	0.77	0.68
CO [g/h]	227.40	1193.69	229.49	52.30	1176.63	149.17	98.24	42.05	139.05	257.05	53.68	47.55
NOx [g/h]	44.24	232.25	44.65	10.18	228.93	29.02	19.11	8.18	27.05	50.01	10.44	9.25
VOC [g/h]	52.70	276.65	53.19	12.12	272.70	34.57	22.77	9.75	32.23	59.57	12.44	11.02

**Other Modes**

g_Walk,mi, Effective Walk Time [s]	8.0			8.0			8.0			8.0		
M_corner, Corner Circulation Area [ft <sup>2</sup> /ped]	0.00			0.00			0.00			0.00		
M_CW, Crosswalk Circulation Area [ft <sup>2</sup> /ped]	0.00			0.00			0.00			0.00		
d_p, Pedestrian Delay [s]	28.13			28.13			28.13			28.13		
I_p,int, Pedestrian LOS Score for Intersectio	3.204			3.166			2.659			2.396		
Crosswalk LOS	C			C			B			B		
s_b, Saturation Flow Rate of the bicycle lane	2000			2000			2000			2000		
c_b, Capacity of the bicycle lane [bicycles/h]	841			841			841			841		
d_b, Bicycle Delay [s]	11.99			12.00			11.99			11.99		
I_b,int, Bicycle LOS Score for Intersection	2.246			2.146			2.106			2.007		
Bicycle LOS	B			B			B			B		

**Sequence**

Ring 1	1	2	3	4	-	-	-	-	-	-	-	-	-	-	-
Ring 2	5	6	7	8	-	-	-	-	-	-	-	-	-	-	-
Ring 3	-	-	-	-	-	-	-	-	-	-	-	-	-	-	-
Ring 4	-	-	-	-	-	-	-	-	-	-	-	-	-	-	-

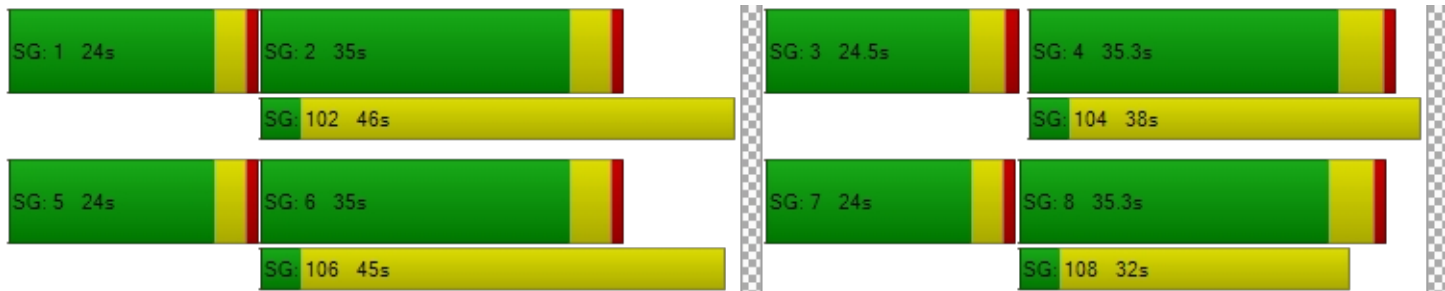

**Intersection Level Of Service Report**  
**Intersection 9: Fallon Road & Dublin Boulevard**

Control Type:	Signalized	Delay (sec / veh):	34.2
Analysis Method:	HCM 7th Edition	Level Of Service:	C
Analysis Period:	15 minutes	Volume to Capacity (v/c):	0.680

**Intersection Setup**

Name	Fallon Road			Fallon Road			Dublin Boulevard			Dublin Boulevard		
Approach	Northbound			Southbound			Eastbound			Westbound		
Lane Configuration	[Diagram]			[Diagram]			[Diagram]			[Diagram]		
Turning Movement	Left	Thru	Right	Left	Thru	Right	Left	Thru	Right	Left	Thru	Right
Lane Width [ft]	12.00	12.00	12.00	12.00	12.00	12.00	12.00	12.00	12.00	12.00	12.00	12.00
No. of Lanes in Entry Pocket	2	0	0	1	0	1	1	0	1	0	0	0
Entry Pocket Length [ft]	430.00	100.00	100.00	140.00	100.00	225.00	400.00	100.00	400.00	100.00	100.00	100.00
No. of Lanes in Exit Pocket	0	0	0	0	0	0	0	0	1	0	0	0
Exit Pocket Length [ft]	0.00	0.00	0.00	0.00	0.00	0.00	0.00	0.00	500.00	0.00	0.00	0.00
Speed [mph]	45.00			45.00			45.00			45.00		
Grade [%]	0.00			0.00			0.00			0.00		
Curb Present	Yes			Yes			Yes			Yes		
Crosswalk	No			No			Yes			Yes		



**Volumes**

Name	Fallon Road			Fallon Road			Dublin Boulevard			Dublin Boulevard		
Base Volume Input [veh/h]	222	903	0	0	996	128	222	446	372	0	0	0
Base Volume Adjustment Factor	1.0000	1.0000	1.0000	1.0000	1.0000	1.0000	1.0000	1.0000	1.0000	1.0000	1.0000	1.0000
Heavy Vehicles Percentage [%]	3.70	0.30	4.00	1.00	0.70	1.60	0.00	4.00	2.20	1.00	1.00	1.00
Proportion of CAVs [%]	0.00											
Growth Factor	1.0000	1.0000	1.0000	1.0000	1.0000	1.0000	1.0000	1.0000	1.0000	1.0000	1.0000	1.0000
In-Process Volume [veh/h]	0	0	0	0	0	0	0	0	0	0	0	0
Site-Generated Trips [veh/h]	0	0	0	0	0	0	0	0	0	0	0	0
Diverted Trips [veh/h]	0	0	0	0	0	0	0	0	0	0	0	0
Pass-by Trips [veh/h]	0	0	0	0	0	0	0	0	0	0	0	0
Existing Site Adjustment Volume [veh/h]	0	0	0	0	0	0	0	0	0	0	0	0
Other Volume [veh/h]	0	0	0	0	0	0	0	0	0	0	0	0
Right Turn on Red Volume [veh/h]	0	0	0	0	0	0	0	0	0	0	0	0
Total Hourly Volume [veh/h]	222	903	0	0	996	128	222	446	372	0	0	0
Peak Hour Factor	0.9400	0.9400	0.9400	0.9400	0.9400	0.9400	0.9400	0.9400	0.9400	0.9400	0.9400	0.9400
Other Adjustment Factor	1.0000	1.0000	1.0000	1.0000	1.0000	1.0000	1.0000	1.0000	1.0000	1.0000	1.0000	1.0000
Total 15-Minute Volume [veh/h]	59	240	0	0	265	34	59	119	99	0	0	0
Total Analysis Volume [veh/h]	236	961	0	0	1060	136	236	474	396	0	0	0
Presence of On-Street Parking	No		No	No		No	No		No	No		No
On-Street Parking Maneuver Rate [/h]	0	0	0	0	0	0	0	0	0	0	0	0
Local Bus Stopping Rate [/h]	0	0	0	0	0	0	0	0	0	0	0	0
v_do, Outbound Pedestrian Volume crossing	0			0			0			0		
v_di, Inbound Pedestrian Volume crossing m	0			0			0			0		
v_co, Outbound Pedestrian Volume crossing	0			2			3			0		
v_ci, Inbound Pedestrian Volume crossing mi	0			3			2			0		
v_ab, Corner Pedestrian Volume [ped/h]	0			0			0			0		
Bicycle Volume [bicycles/h]	0			1			0			0		





**Intersection Settings**

Located in CBD	No
Signal Coordination Group	-
Cycle Length [s]	140
Active Pattern	Pattern 1
Coordination Type	Time of Day Pattern Isolated
Actuation Type	Fully actuated
Offset [s]	0.0
Offset Reference	Lead Green - Beginning of First Green
Permissive Mode	SingleBand
Lost time [s]	12.00

**Phasing & Timing (Basic)**

Control Type	Protecte	Permiss	Permiss	Protecte	Permiss	Permiss	Protecte	Permiss	Overlap	Protecte	Permiss	Permiss
Signal Group	3	8	0	7	4	0	5	2	2	1	6	0
Auxiliary Signal Groups									2,3			
Maximum Green [s]	30	30	0	12	30	0	30	30	30	12	12	0
Amber [s]	4.3	4.7	0.0	4.3	4.7	0.0	4.3	4.3	4.3	3.0	4.8	0.0
All red [s]	1.0	1.0	0.0	1.0	1.0	0.0	1.0	1.0	1.0	1.0	1.0	0.0
Walk [s]	0	0	0	0	4	0	0	0	0	0	0	0
Pedestrian Clearance [s]	0	0	0	0	41	0	0	0	0	0	0	0
Delayed Vehicle Green [s]	0.0	0.0	0.0	0.0	0.0	0.0	0.0	0.0	0.0	0.0	0.0	0.0
Rest In Walk		No			No			No			No	
I1, Start-Up Lost Time [s]	2.0	2.0	0.0	2.0	2.0	0.0	2.0	2.0	2.0	2.0	2.0	0.0
I2, Clearance Lost Time [s]	2.0	2.0	0.0	2.0	2.0	0.0	2.0	2.0	2.0	2.0	2.0	0.0
Detector Location [ft]	0.0	0.0	0.0	0.0	0.0	0.0	0.0	0.0	0.0	0.0	0.0	0.0
Detector Length [ft]	20.0	20.0	0.0	20.0	20.0	0.0	0.0	0.0	0.0	20.0	20.0	0.0
I, Upstream Filtering Factor	1.00	1.00	1.00	1.00	1.00	1.00	1.00	1.00	1.00	1.00	1.00	1.00

**Phasing & Timing: Pattern 1**

Split [s]	35	65	0	20	50	0	35	35	35	20	20	0
Lead / Lag	Lead	-	-	Lead	-	-	Lead	-	-	Lead	-	-
Minimum Green [s]	10	12	0	10	12	0	10	12	12	10	10	0
Vehicle Extension [s]	2.0	4.0	0.0	2.0	4.0	0.0	2.0	4.0	4.0	2.0	2.0	0.0
Minimum Recall	No	Yes		No	Yes		No	No	No	No	No	
Maximum Recall	No	No		No	No		No	No	No	No	No	
Pedestrian Recall	No	No		No	No		No	No	No	No	No	

**Exclusive Pedestrian Phase**

Pedestrian Signal Group	0
Pedestrian Walk [s]	0
Pedestrian Clearance [s]	0



**Lane Group Calculations**

Lane Group	L	C	C	L	C	R	L	C	R	L	C
C, Cycle Length [s]	140	140	140	140	140	140	140	140	140	140	140
L, Total Lost Time per Cycle [s]	4.00	4.00	4.00	4.00	4.00	4.00	4.00	4.00	4.00	4.00	4.00
l1_p, Permitted Start-Up Lost Time [s]	0.00	0.00	0.00	0.00	0.00	0.00	0.00	0.00	0.00	0.00	0.00
l2, Clearance Lost Time [s]	2.00	2.00	2.00	2.00	2.00	2.00	2.00	2.00	0.00	2.00	2.00
g_i, Effective Green Time [s]	18	82	82	1	65	65	13	41	63	0	28
g / C, Green / Cycle	0.13	0.59	0.59	0.01	0.46	0.46	0.09	0.29	0.45	0.00	0.20
(v / s)_i Volume / Saturation Flow Rate	0.07	0.25	0.25	0.00	0.29	0.09	0.07	0.26	0.14	0.00	0.00
s, saturation flow rate [veh/h]	3411	1895	1895	1795	3598	1570	3514	1840	2809	1795	1885
c, Capacity [veh/h]	447	1111	1111	17	1671	729	320	533	1236	1	375
d1, Uniform Delay [s]	56.74	16.05	16.05	0.00	28.43	21.93	61.96	47.57	25.54	0.00	0.00
k, delay calibration	0.04	0.50	0.50	0.04	0.50	0.50	0.04	0.33	0.15	0.04	0.04
l, Upstream Filtering Factor	1.00	1.00	1.00	1.00	1.00	1.00	1.00	1.00	1.00	1.00	1.00
d2, Incremental Delay [s]	0.36	1.23	1.23	0.00	1.85	0.56	1.25	14.09	0.21	0.00	0.00
d3, Initial Queue Delay [s]	0.00	0.00	0.00	0.00	0.00	0.00	0.00	0.00	0.00	0.00	0.00
Rp, platoon ratio	1.00	1.00	1.00	1.00	1.00	1.00	1.00	1.00	1.00	1.00	1.00
PF, progression factor	1.00	1.00	1.00	1.00	1.00	1.00	1.00	1.00	1.00	1.00	1.00

**Lane Group Results**

X, volume / capacity	0.53	0.43	0.43	0.00	0.63	0.19	0.74	0.89	0.32	0.00	0.00
d, Delay for Lane Group [s/veh]	57.10	17.28	17.28	0.00	30.28	22.49	63.21	61.66	25.75	0.00	0.00
Lane Group LOS	E	B	B	A	C	C	E	E	C	A	A
Critical Lane Group	Yes	No	No	No	Yes	No	No	Yes	No	No	No
50th-Percentile Queue Length [veh/ln]	3.85	8.44	8.44	0.00	13.39	2.68	4.08	17.44	4.23	0.00	0.00
50th-Percentile Queue Length [ft/ln]	96.34	210.96	210.96	0.00	334.71	66.97	101.88	435.99	105.80	0.00	0.00
95th-Percentile Queue Length [veh/ln]	6.94	13.20	13.20	0.00	19.39	4.82	7.34	24.29	7.61	0.00	0.00
95th-Percentile Queue Length [ft/ln]	173.41	330.07	330.07	0.00	484.73	120.55	183.38	607.21	190.15	0.00	0.00



**Movement, Approach, & Intersection Results**

d_M, Delay for Movement [s/veh]	57.10	17.28	17.28	0.00	30.28	22.49	63.21	61.66	25.75	0.00	0.00	0.00
Movement LOS	E	B	B	A	C	C	E	E	C	A	A	A
d_A, Approach Delay [s/veh]	25.13			29.39			49.14			0.00		
Approach LOS	C			C			D			A		
d_I, Intersection Delay [s/veh]	34.18											
Intersection LOS	C											
Intersection V/C	0.680											

**Emissions**

Vehicle Miles Traveled [mph]	31.70	64.53	64.53	0.00	280.66	36.01	283.94	570.29	476.45	0.00	0.00
Stops [stops/h]	198.22	217.04	217.04	0.00	688.70	68.90	209.62	448.55	217.70	0.00	0.00
Fuel consumption [US gal/h]	6.29	6.60	6.60	0.00	24.71	2.71	15.37	31.07	21.11	0.00	0.00
CO [g/h]	439.89	461.37	461.37	0.00	1727.54	189.67	1074.67	2171.99	1475.84	0.00	0.00
NOx [g/h]	85.59	89.77	89.77	0.00	336.12	36.90	209.09	422.59	287.14	0.00	0.00
VOC [g/h]	101.95	106.93	106.93	0.00	400.37	43.96	249.07	503.38	342.04	0.00	0.00

**Other Modes**

g_Walk,mi, Effective Walk Time [s]	0.0			0.0			8.0			59.3		
M_corner, Corner Circulation Area [ft <sup>2</sup> /ped]	0.00			0.00			0.00			0.00		
M_CW, Crosswalk Circulation Area [ft <sup>2</sup> /ped]	0.00			0.00			787.82			0.00		
d_p, Pedestrian Delay [s]	0.00			0.00			62.21			23.25		
I_p,int, Pedestrian LOS Score for Intersectio	0.000			0.000			3.019			2.288		
Crosswalk LOS	F			F			C			B		
s_b, Saturation Flow Rate of the bicycle lane	2000			2000			2000			2000		
c_b, Capacity of the bicycle lane [bicycles/h]	847			633			424			203		
d_b, Bicycle Delay [s]	23.25			32.71			43.44			56.50		
I_b,int, Bicycle LOS Score for Intersection	2.547			2.546			3.385			1.560		
Bicycle LOS	B			B			C			A		

**Sequence**

Ring 1	1	2	3	4	-	-	-	-	-	-	-	-	-	-	-
Ring 2	5	6	7	8	-	-	-	-	-	-	-	-	-	-	-
Ring 3	-	-	-	-	-	-	-	-	-	-	-	-	-	-	-
Ring 4	-	-	-	-	-	-	-	-	-	-	-	-	-	-	-



**Intersection Level Of Service Report**  
**Intersection 10: Fallon Road & Fallon Gateway**

Control Type:	Signalized	Delay (sec / veh):	13.4
Analysis Method:	HCM 7th Edition	Level Of Service:	B
Analysis Period:	15 minutes	Volume to Capacity (v/c):	0.625

**Intersection Setup**

Name	Fallon Road		Fallon Road		Fallon Gateway	
Approach	Northbound		Southbound		Eastbound	
Lane Configuration	⇐⇐		⇐		⇐⇐⇐⇐	
Turning Movement	Left	Thru	Thru	Right	Left	Right
Lane Width [ft]	12.00	12.00	12.00	12.00	12.00	12.00
No. of Lanes in Entry Pocket	1	0	0	0	1	1
Entry Pocket Length [ft]	275.00	100.00	100.00	100.00	210.00	210.00
No. of Lanes in Exit Pocket	0	0	0	0	0	0
Exit Pocket Length [ft]	0.00	0.00	0.00	0.00	0.00	0.00
Speed [mph]	45.00		40.00		25.00	
Grade [%]	0.00		0.00		0.00	
Curb Present	Yes		Yes		Yes	
Crosswalk	No		No		Yes	



**Volumes**

Name	Fallon Road		Fallon Road		Fallon Gateway	
Base Volume Input [veh/h]	308	1085	1098	105	62	304
Base Volume Adjustment Factor	1.0000	1.0000	1.0000	1.0000	1.0000	1.0000
Heavy Vehicles Percentage [%]	1.00	0.60	1.30	1.00	0.00	1.30
Proportion of CAVs [%]	0.00					
Growth Factor	1.0000	1.0000	1.0000	1.0000	1.0000	1.0000
In-Process Volume [veh/h]	0	0	0	0	0	0
Site-Generated Trips [veh/h]	0	0	0	0	0	0
Diverted Trips [veh/h]	0	0	0	0	0	0
Pass-by Trips [veh/h]	0	0	0	0	0	0
Existing Site Adjustment Volume [veh/h]	0	0	0	0	0	0
Other Volume [veh/h]	0	0	0	0	0	0
Right Turn on Red Volume [veh/h]	0	0	0	0	0	0
Total Hourly Volume [veh/h]	308	1085	1098	105	62	304
Peak Hour Factor	0.9400	0.9400	0.9400	0.9400	0.9400	0.9400
Other Adjustment Factor	1.0000	1.0000	1.0000	1.0000	1.0000	1.0000
Total 15-Minute Volume [veh/h]	82	289	292	28	16	81
Total Analysis Volume [veh/h]	328	1154	1168	112	66	323
Presence of On-Street Parking	No	No	No	No	No	No
On-Street Parking Maneuver Rate [/h]	0	0	0	0	0	0
Local Bus Stopping Rate [/h]	0	0	0	0	0	0
v_do, Outbound Pedestrian Volume crossing	0		0		0	
v_di, Inbound Pedestrian Volume crossing m	0		0		0	
v_co, Outbound Pedestrian Volume crossing	0		0		0	
v_ci, Inbound Pedestrian Volume crossing mi	0		0		0	
v_ab, Corner Pedestrian Volume [ped/h]	0		0		0	
Bicycle Volume [bicycles/h]	0		0		0	



**Intersection Settings**

Located in CBD	No
Signal Coordination Group	-
Cycle Length [s]	105
Active Pattern	Pattern 1
Coordination Type	Time of Day Pattern Isolated
Actuation Type	Fully actuated
Offset [s]	0.0
Offset Reference	Lead Green - Beginning of First Green
Permissive Mode	SingleBand
Lost time [s]	9.00

**Phasing & Timing (Basic)**

Control Type	Protected	Permissive	Permissive	Permissive	Permissive	Overlap
Signal Group	3	8	4	0	2	2
Auxiliary Signal Groups						2,3
Maximum Green [s]	20	40	40	0	30	30
Amber [s]	3.5	4.7	4.7	0.0	3.5	3.5
All red [s]	1.0	1.0	1.0	0.0	1.0	1.0
Walk [s]	0	0	4	0	0	0
Pedestrian Clearance [s]	0	0	28	0	0	0
Delayed Vehicle Green [s]	0.0	0.0	0.0	0.0	0.0	0.0
Rest In Walk		No	No		No	
I1, Start-Up Lost Time [s]	2.0	2.0	2.0	0.0	2.0	2.0
I2, Clearance Lost Time [s]	2.5	3.7	3.7	0.0	2.5	2.5
Detector Location [ft]	0.0	0.0	0.0	0.0	0.0	0.0
Detector Length [ft]	20.0	20.0	0.0	0.0	20.0	20.0
I, Upstream Filtering Factor	1.00	1.00	1.00	1.00	1.00	1.00

**Phasing & Timing: Pattern 1**

Split [s]	25	70	45	0	35	35
Lead / Lag	Lead	-	-	-	Lead	-
Minimum Green [s]	10	10	10	0	10	10
Vehicle Extension [s]	2.0	5.0	5.0	0.0	2.0	2.0
Minimum Recall	No	Yes	Yes		No	No
Maximum Recall	No	No	No		No	No
Pedestrian Recall	No	No	No		No	No

**Exclusive Pedestrian Phase**

Pedestrian Signal Group	0
Pedestrian Walk [s]	0
Pedestrian Clearance [s]	0



**Lane Group Calculations**

Lane Group	L	C	C	C	L	R
C, Cycle Length [s]	65	65	65	65	65	65
L, Total Lost Time per Cycle [s]	4.50	5.70	5.70	5.70	4.50	4.50
l1_p, Permitted Start-Up Lost Time [s]	0.00	0.00	0.00	0.00	0.00	0.00
l2, Clearance Lost Time [s]	2.50	3.70	3.70	3.70	2.50	0.00
g_i, Effective Green Time [s]	10	44	30	30	10	24
g / C, Green / Cycle	0.15	0.69	0.46	0.46	0.15	0.38
(v / s)_i Volume / Saturation Flow Rate	0.09	0.32	0.34	0.35	0.02	0.11
s, saturation flow rate [veh/h]	3486	3600	1880	1824	3514	2829
c, Capacity [veh/h]	538	2475	872	846	544	1072
d1, Uniform Delay [s]	25.53	4.65	14.11	14.34	23.55	14.09
k, delay calibration	0.04	0.23	0.23	0.24	0.04	0.04
l, Upstream Filtering Factor	1.00	1.00	1.00	1.00	1.00	1.00
d2, Incremental Delay [s]	0.42	0.29	2.60	3.11	0.04	0.06
d3, Initial Queue Delay [s]	0.00	0.00	0.00	0.00	0.00	0.00
Rp, platoon ratio	1.00	1.00	1.00	1.00	1.00	1.00
PF, progression factor	1.00	1.00	1.00	1.00	1.00	1.00

**Lane Group Results**

X, volume / capacity	0.61	0.47	0.73	0.76	0.12	0.30
d, Delay for Lane Group [s/veh]	25.94	4.94	16.71	17.45	23.58	14.15
Lane Group LOS	C	A	B	B	C	B
Critical Lane Group	Yes	No	No	Yes	No	Yes
50th-Percentile Queue Length [veh/ln]	2.13	1.84	6.74	6.94	0.42	1.56
50th-Percentile Queue Length [ft/ln]	53.32	45.96	168.46	173.46	10.59	38.90
95th-Percentile Queue Length [veh/ln]	3.84	3.31	11.00	11.26	0.76	2.80
95th-Percentile Queue Length [ft/ln]	95.97	82.73	274.90	281.45	19.06	70.02

**Movement, Approach, & Intersection Results**

d_M, Delay for Movement [s/veh]	25.94	4.94	17.04	17.45	23.58	14.15
Movement LOS	C	A	B	B	C	B
d_A, Approach Delay [s/veh]	9.59		17.08		15.75	
Approach LOS	A		B		B	
d_I, Intersection Delay [s/veh]	13.39					
Intersection LOS	B					
Intersection V/C	0.625					

**Emissions**

Vehicle Miles Traveled [mph]	49.90	175.58	85.96	85.96	4.05	19.82
Stops [stops/h]	237.69	204.89	375.50	386.62	47.20	173.42
Fuel consumption [US gal/h]	6.40	9.73	8.94	9.15	0.68	2.49
CO [g/h]	447.20	679.86	625.21	639.57	47.53	173.81
NOx [g/h]	87.01	132.28	121.64	124.44	9.25	33.82
VOC [g/h]	103.64	157.56	144.90	148.23	11.01	40.28

**Other Modes**

g_Walk,mi, Effective Walk Time [s]	0.0		0.0		8.0	
M_corner, Corner Circulation Area [ft <sup>2</sup> /ped]	0.00		0.00		0.00	
M_CW, Crosswalk Circulation Area [ft <sup>2</sup> /ped]	0.00		0.00		0.00	
d_p, Pedestrian Delay [s]	0.00		0.00		24.80	
I_p,int, Pedestrian LOS Score for Intersectio	0.000		0.000		2.551	
Crosswalk LOS	F		F		B	
s_b, Saturation Flow Rate of the bicycle lane	2000		2000		2000	
c_b, Capacity of the bicycle lane [bicycles/h]	1991		1217		944	
d_b, Bicycle Delay [s]	0.00		4.96		9.00	
I_b,int, Bicycle LOS Score for Intersection	2.782		2.616		1.560	
Bicycle LOS	C		B		A	

**Sequence**

Ring 1	-	2	3	4	-	-	-	-	-	-	-	-	-	-	-	-
Ring 2	-	-	-	8	-	-	-	-	-	-	-	-	-	-	-	-
Ring 3	-	-	-	-	-	-	-	-	-	-	-	-	-	-	-	-
Ring 4	-	-	-	-	-	-	-	-	-	-	-	-	-	-	-	-

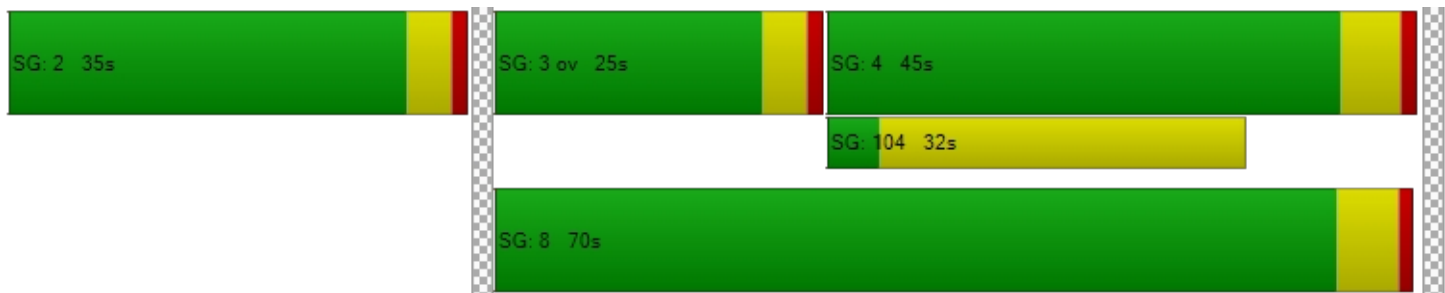



**Intersection Level Of Service Report**  
**Intersection 11: Fallon Road & I-580 WB Ramps**

Control Type:	Signalized	Delay (sec / veh):	24.5
Analysis Method:	HCM 7th Edition	Level Of Service:	C
Analysis Period:	15 minutes	Volume to Capacity (v/c):	0.586

**Intersection Setup**

Name	Fallon Road			Fallon Road			I-580 WB On-Ramp			I-580 WB Off-Ramp		
Approach	Northbound			Southbound			Eastbound			Westbound		
Lane Configuration	↑			↑↑↑						↑↑↑↑		
Turning Movement	Left	Thru	Right	Left	Thru	Right	Left	Thru	Right	Left	Thru	Right
Lane Width [ft]	12.00	12.00	12.00	12.00	12.00	12.00	12.00	12.00	12.00	12.00	12.00	12.00
No. of Lanes in Entry Pocket	0	0	0	0	0	1	0	0	0	1	0	1
Entry Pocket Length [ft]	100.00	100.00	100.00	100.00	100.00	225.00	100.00	100.00	100.00	170.00	100.00	130.00
No. of Lanes in Exit Pocket	0	0	1	0	0	0	0	0	1	0	0	0
Exit Pocket Length [ft]	0.00	0.00	400.00	0.00	0.00	0.00	0.00	0.00	400.00	0.00	0.00	0.00
Speed [mph]	45.00			40.00			30.00			35.00		
Grade [%]	0.00			0.00			0.00			0.00		
Curb Present	No			No						No		
Crosswalk	No			No			No			No		



**Volumes**

Name	Fallon Road			Fallon Road			I-580 WB On-Ramp			I-580 WB Off-Ramp		
	Base Volume Input [veh/h]	0	850	0	0	1049	620	0	0	0	285	1
Base Volume Adjustment Factor	1.0000	1.0000	1.0000	1.0000	1.0000	1.0000	1.0000	1.0000	1.0000	1.0000	1.0000	1.0000
Heavy Vehicles Percentage [%]	2.00	0.10	2.00	2.00	0.60	1.00	2.00	2.00	2.00	0.80	0.00	1.50
Proportion of CAVs [%]	0.00											
Growth Factor	1.0000	1.0000	1.0000	1.0000	1.0000	1.0000	1.0000	1.0000	1.0000	1.0000	1.0000	1.0000
In-Process Volume [veh/h]	0	0	0	0	0	0	0	0	0	0	0	0
Site-Generated Trips [veh/h]	0	0	0	0	0	0	0	0	0	0	0	0
Diverted Trips [veh/h]	0	0	0	0	0	0	0	0	0	0	0	0
Pass-by Trips [veh/h]	0	0	0	0	0	0	0	0	0	0	0	0
Existing Site Adjustment Volume [veh/h]	0	0	0	0	0	0	0	0	0	0	0	0
Other Volume [veh/h]	0	0	0	0	0	0	0	0	0	0	0	0
Right Turn on Red Volume [veh/h]	0	0	0	0	0	0	0	0	0	0	0	0
Total Hourly Volume [veh/h]	0	850	0	0	1049	620	0	0	0	285	1	590
Peak Hour Factor	1.0000	0.9500	1.0000	1.0000	0.9500	0.9500	1.0000	1.0000	1.0000	0.9500	0.9500	0.9500
Other Adjustment Factor	1.0000	1.0000	1.0000	1.0000	1.0000	1.0000	1.0000	1.0000	1.0000	1.0000	1.0000	1.0000
Total 15-Minute Volume [veh/h]	0	224	0	0	276	163	0	0	0	75	0	155
Total Analysis Volume [veh/h]	0	895	0	0	1104	653	0	0	0	300	1	621
Presence of On-Street Parking	No		No	No		No				No		No
On-Street Parking Maneuver Rate [/h]	0	0	0	0	0	0	0	0	0	0	0	0
Local Bus Stopping Rate [/h]	0	0	0	0	0	0	0	0	0	0	0	0
v_do, Outbound Pedestrian Volume crossing	0			0			0			0		
v_di, Inbound Pedestrian Volume crossing m	0			0			0			0		
v_co, Outbound Pedestrian Volume crossing	0			0			0			0		
v_ci, Inbound Pedestrian Volume crossing mi	0			0			0			0		
v_ab, Corner Pedestrian Volume [ped/h]	0			0			0			0		
Bicycle Volume [bicycles/h]	0			0			0			0		



**Intersection Settings**

Located in CBD	No
Signal Coordination Group	-
Cycle Length [s]	90
Active Pattern	Free Running (No Pattern)
Coordination Type	Free Running
Actuation Type	Fully actuated
Offset [s]	0.0
Offset Reference	Lead Green - Beginning of First Green
Permissive Mode	SingleBand
Lost time [s]	9.00

**Phasing & Timing (Basic)**

Control Type	Permiss	Permiss	Permiss	Permiss	Permiss	Permiss	Permiss	Permiss	Permiss	Permiss	Permiss	Overlap
Signal Group	0	2	0	0	6	0	0	0	0	0	8	1
Auxiliary Signal Groups												1,8
Maximum Green [s]	0	35	0	0	35	0	0	0	0	0	20	15
Amber [s]	0.0	4.8	0.0	0.0	4.8	0.0	0.0	0.0	0.0	0.0	3.7	3.7
All red [s]	0.0	0.5	0.0	0.0	0.5	0.0	0.0	0.0	0.0	0.0	0.5	0.5
Walk [s]	0	0	0	0	0	0	0	0	0	0	0	0
Pedestrian Clearance [s]	0	0	0	0	0	0	0	0	0	0	0	0
Delayed Vehicle Green [s]	0.0	0.0	0.0	0.0	0.0	0.0	0.0	0.0	0.0	0.0	0.0	0.0
Rest In Walk		No			No						No	
I1, Start-Up Lost Time [s]	0.0	2.0	0.0	0.0	2.0	0.0	0.0	0.0	0.0	0.0	2.0	2.0
I2, Clearance Lost Time [s]	0.0	3.3	0.0	0.0	3.3	0.0	0.0	0.0	0.0	0.0	2.2	2.2
Detector Location [ft]	0.0	0.0	0.0	0.0	0.0	0.0	0.0	0.0	0.0	0.0	0.0	0.0
Detector Length [ft]	0.0	20.0	0.0	0.0	20.0	0.0	0.0	0.0	0.0	0.0	20.0	20.0
I, Upstream Filtering Factor	1.00	1.00	1.00	1.00	1.00	1.00	1.00	1.00	1.00	1.00	1.00	1.00

**Phasing & Timing: Free Running (No Pattern)**

Split [s]	0	0	0	0	0	0	0	0	0	0	0	0
Lead / Lag	-	-	-	-	-	-	-	-	-	-	-	-
Minimum Green [s]	0	10	0	0	10	0	0	0	0	0	5	4
Vehicle Extension [s]	0.0	0.0	0.0	0.0	0.0	0.0	0.0	0.0	0.0	0.0	0.0	0.0
Minimum Recall		Yes			Yes						No	No
Maximum Recall		No			No						No	No
Pedestrian Recall		No			No						No	No

**Exclusive Pedestrian Phase**

Pedestrian Signal Group	0
Pedestrian Walk [s]	0
Pedestrian Clearance [s]	0



**Lane Group Calculations**

Lane Group	C	C	R		L	C	R
C, Cycle Length [s]	78	78	78		78	78	78
L, Total Lost Time per Cycle [s]	5.30	5.30	5.30		4.20	4.20	4.20
l1_p, Permitted Start-Up Lost Time [s]	0.00	0.00	0.00		0.00	0.00	0.00
l2, Clearance Lost Time [s]	3.30	3.30	3.30		2.20	2.20	0.00
g_i, Effective Green Time [s]	35	54	54		15	15	33
g / C, Green / Cycle	0.45	0.69	0.69		0.19	0.19	0.43
(v / s)_i Volume / Saturation Flow Rate	0.47	0.31	0.41		0.08	0.08	0.22
s, saturation flow rate [veh/h]	1898	3600	1602		1798	1810	2825
c, Capacity [veh/h]	854	2486	1106		337	339	1210
d1, Uniform Delay [s]	21.42	5.38	6.29		28.03	28.03	16.31
k, delay calibration	0.46	0.04	0.34		0.04	0.04	0.04
l, Upstream Filtering Factor	1.00	1.00	1.00		1.00	1.00	1.00
d2, Incremental Delay [s]	43.08	0.05	1.59		0.34	0.34	0.13
d3, Initial Queue Delay [s]	0.00	0.00	0.00		0.00	0.00	0.00
Rp, platoon ratio	1.00	1.00	1.00		1.00	1.00	1.00
PF, progression factor	1.00	1.00	1.00		1.00	1.00	1.00

**Lane Group Results**

X, volume / capacity	1.05	0.44	0.59		0.45	0.44	0.51
d, Delay for Lane Group [s/veh]	64.49	5.42	7.88		28.38	28.37	16.43
Lane Group LOS	F	A	A		C	C	B
Critical Lane Group	Yes	No	No		No	No	Yes
50th-Percentile Queue Length [veh/ln]	23.13	2.68	4.18		2.40	2.41	3.70
50th-Percentile Queue Length [ft/ln]	578.31	67.03	104.46		59.96	60.33	92.57
95th-Percentile Queue Length [veh/ln]	32.13	4.83	7.52		4.32	4.34	6.66
95th-Percentile Queue Length [ft/ln]	803.19	120.66	188.03		107.92	108.60	166.62



**Movement, Approach, & Intersection Results**

d_M, Delay for Movement [s/veh]	0.00	64.49	0.00	0.00	5.42	7.88	0.00	0.00	0.00	28.37	28.37	16.43
Movement LOS		F			A	A				C	C	B
d_A, Approach Delay [s/veh]	64.49		6.34			0.00			20.33			
Approach LOS	E		A			A			C			
d_I, Intersection Delay [s/veh]	24.51											
Intersection LOS	C											
Intersection V/C	0.586											

**Emissions**

Vehicle Miles Traveled [mph]	93.28	167.97	99.35	21.76	21.90	90.09
Stops [stops/h]	1070.24	248.10	193.32	110.96	111.66	342.62
Fuel consumption [US gal/h]	28.25	9.67	6.51	2.53	2.55	8.09
CO [g/h]	1974.65	676.10	454.72	176.87	177.99	565.30
NOx [g/h]	384.20	131.54	88.47	34.41	34.63	109.99
VOC [g/h]	457.64	156.69	105.39	40.99	41.25	131.01

**Other Modes**

g_Walk,mi, Effective Walk Time [s]	0.0	0.0	0.0	0.0
M_corner, Corner Circulation Area [ft <sup>2</sup> /ped]	0.00	0.00	0.00	0.00
M_CW, Crosswalk Circulation Area [ft <sup>2</sup> /ped]	0.00	0.00	0.00	0.00
d_p, Pedestrian Delay [s]	0.00	0.00	0.00	0.00
I_p,int, Pedestrian LOS Score for Intersectio	0.000	0.000	0.000	0.000
Crosswalk LOS	F	F	F	F
s_b, Saturation Flow Rate of the bicycle lane	2000	2000	2000	2000
c_b, Capacity of the bicycle lane [bicycles/h]	900	900	0	514
d_b, Bicycle Delay [s]	11.78	11.78	38.91	21.48
I_b,int, Bicycle LOS Score for Intersection	3.036	3.009	4.132	3.081
Bicycle LOS	C	C	D	C

**Sequence**

Ring 1	1	2	-	-	-	-	-	-	-	-	-	-	-	-	-
Ring 2	-	6	-	8	-	-	-	-	-	-	-	-	-	-	-
Ring 3	-	-	-	-	-	-	-	-	-	-	-	-	-	-	-
Ring 4	-	-	-	-	-	-	-	-	-	-	-	-	-	-	-



**Intersection Level Of Service Report**  
**Intersection 12: El Charro Road & I-580 EB Ramps**

Control Type:	Signalized	Delay (sec / veh):	7.2
Analysis Method:	HCM 7th Edition	Level Of Service:	A
Analysis Period:	15 minutes	Volume to Capacity (v/c):	0.602

**Intersection Setup**

Name	El Charro Road			Fallon Road			I-580 EB Off-Ramp			I-580 EB On-Ramp		
Approach	Northbound			Southbound			Eastbound			Westbound		
Lane Configuration	↑↑			↑↑			↵↵↵↵					
Turning Movement	Left	Thru	Right	Left	Thru	Right	Left	Thru	Right	Left	Thru	Right
Lane Width [ft]	12.00	12.00	12.00	12.00	12.00	12.00	12.00	12.00	12.00	12.00	12.00	12.00
No. of Lanes in Entry Pocket	0	0	0	1	0	0	1	0	1	0	0	0
Entry Pocket Length [ft]	100.00	100.00	100.00	135.00	100.00	100.00	350.00	100.00	350.00	100.00	100.00	100.00
No. of Lanes in Exit Pocket	0	0	0	0	0	1	0	0	0	0	0	0
Exit Pocket Length [ft]	0.00	0.00	0.00	0.00	0.00	100.00	0.00	0.00	0.00	0.00	0.00	0.00
Speed [mph]	30.00			40.00			35.00			30.00		
Grade [%]	0.00			0.00			0.00			0.00		
Curb Present	No			No			No					
Crosswalk	No			No			No			Yes		



**Volumes**

Name	El Charro Road			Fallon Road			I-580 EB Off-Ramp			I-580 EB On-Ramp		
Base Volume Input [veh/h]	0	875	0	0	824	0	399	0	362	0	0	0
Base Volume Adjustment Factor	1.0000	1.0000	1.0000	1.0000	1.0000	1.0000	1.0000	1.0000	1.0000	1.0000	1.0000	1.0000
Heavy Vehicles Percentage [%]	2.00	0.80	2.00	2.00	0.40	2.00	0.30	2.00	1.80	2.00	2.00	2.00
Proportion of CAVs [%]	0.00											
Growth Factor	1.0000	1.0000	1.0000	1.0000	1.0000	1.0000	1.0000	1.0000	1.0000	1.0000	1.0000	1.0000
In-Process Volume [veh/h]	0	0	0	0	0	0	0	0	0	0	0	0
Site-Generated Trips [veh/h]	0	0	0	0	0	0	0	0	0	0	0	0
Diverted Trips [veh/h]	0	0	0	0	0	0	0	0	0	0	0	0
Pass-by Trips [veh/h]	0	0	0	0	0	0	0	0	0	0	0	0
Existing Site Adjustment Volume [veh/h]	0	0	0	0	0	0	0	0	0	0	0	0
Other Volume [veh/h]	0	0	0	0	0	0	0	0	0	0	0	0
Right Turn on Red Volume [veh/h]	0	0	0	0	0	0	0	0	0	0	0	0
Total Hourly Volume [veh/h]	0	875	0	0	824	0	399	0	362	0	0	0
Peak Hour Factor	1.0000	0.9600	1.0000	1.0000	0.9600	1.0000	0.9600	1.0000	0.9600	1.0000	1.0000	1.0000
Other Adjustment Factor	1.0000	1.0000	1.0000	1.0000	1.0000	1.0000	1.0000	1.0000	1.0000	1.0000	1.0000	1.0000
Total 15-Minute Volume [veh/h]	0	228	0	0	215	0	104	0	94	0	0	0
Total Analysis Volume [veh/h]	0	911	0	0	858	0	416	0	377	0	0	0
Presence of On-Street Parking	No		No	No		No	No		No			
On-Street Parking Maneuver Rate [/h]	0	0	0	0	0	0	0	0	0	0	0	0
Local Bus Stopping Rate [/h]	0	0	0	0	0	0	0	0	0	0	0	0
v_do, Outbound Pedestrian Volume crossing	0			0			0			0		
v_di, Inbound Pedestrian Volume crossing m	0			0			0			0		
v_co, Outbound Pedestrian Volume crossing	0			0			0			0		
v_ci, Inbound Pedestrian Volume crossing mi	0			0			0			0		
v_ab, Corner Pedestrian Volume [ped/h]	0			0			0			0		
Bicycle Volume [bicycles/h]	0			0			0			0		



**Intersection Settings**

Located in CBD	No
Signal Coordination Group	-
Cycle Length [s]	90
Active Pattern	Free Running (No Pattern)
Coordination Type	<i>Free Running</i>
Actuation Type	<i>Fully actuated</i>
Offset [s]	0.0
Offset Reference	Lead Green - Beginning of First Green
Permissive Mode	SingleBand
Lost time [s]	9.00

**Phasing & Timing (Basic)**

Control Type	Permiss	Permiss	Permiss	Permiss	Permiss	Permiss	Permiss	Permiss	Permiss	Permiss	Permiss	Permiss
Signal Group	0	2	0	0	6	0	4	0	0	0	0	0
Auxiliary Signal Groups												
Maximum Green [s]	0	40	0	0	40	0	26	0	0	0	0	0
Amber [s]	0.0	4.8	0.0	0.0	4.8	0.0	3.7	0.0	0.0	0.0	0.0	0.0
All red [s]	0.0	1.0	0.0	0.0	1.0	0.0	0.5	0.0	0.0	0.0	0.0	0.0
Walk [s]	0	0	0	0	0	0	0	0	0	0	0	0
Pedestrian Clearance [s]	0	0	0	0	0	0	0	0	0	0	0	0
Delayed Vehicle Green [s]	0.0	0.0	0.0	0.0	0.0	0.0	0.0	0.0	0.0	0.0	0.0	0.0
Rest In Walk		No			No		No					
I1, Start-Up Lost Time [s]	0.0	2.0	0.0	0.0	2.0	0.0	2.0	0.0	0.0	0.0	0.0	0.0
I2, Clearance Lost Time [s]	0.0	3.3	0.0	0.0	3.3	0.0	2.7	0.0	0.0	0.0	0.0	0.0
Detector Location [ft]	0.0	0.0	0.0	0.0	0.0	0.0	0.0	0.0	0.0	0.0	0.0	0.0
Detector Length [ft]	0.0	0.0	0.0	0.0	0.0	0.0	0.0	0.0	0.0	0.0	0.0	0.0
I, Upstream Filtering Factor	1.00	1.00	1.00	1.00	1.00	1.00	1.00	1.00	1.00	1.00	1.00	1.00

**Phasing & Timing: Free Running (No Pattern)**

Split [s]	0	0	0	0	0	0	0	0	0	0	0	0
Lead / Lag	-	-	-	-	-	-	Lead	-	-	-	-	-
Minimum Green [s]	0	10	0	0	10	0	4	0	0	0	0	0
Vehicle Extension [s]	0.0	0.0	0.0	0.0	0.0	0.0	0.0	0.0	0.0	0.0	0.0	0.0
Minimum Recall		Yes			Yes		No					
Maximum Recall		No			No		No					
Pedestrian Recall		No			No		No					

**Exclusive Pedestrian Phase**

Pedestrian Signal Group	0
Pedestrian Walk [s]	0
Pedestrian Clearance [s]	0





**Lane Group Calculations**

Lane Group	C	C	L	R	
C, Cycle Length [s]	25	25	25	25	
L, Total Lost Time per Cycle [s]	5.30	5.30	4.70	4.70	
l1_p, Permitted Start-Up Lost Time [s]	0.00	0.00	0.00	0.00	
l2, Clearance Lost Time [s]	3.30	3.30	2.70	2.70	
g_i, Effective Green Time [s]	11	11	5	5	
g / C, Green / Cycle	0.42	0.42	0.19	0.19	
(v / s)_i Volume / Saturation Flow Rate	0.25	0.24	0.12	0.13	
s, saturation flow rate [veh/h]	3595	3606	3506	2818	
c, Capacity [veh/h]	1497	1502	664	533	
d1, Uniform Delay [s]	5.78	5.67	9.46	9.63	
k, delay calibration	0.04	0.04	0.04	0.04	
l, Upstream Filtering Factor	1.00	1.00	1.00	1.00	
d2, Incremental Delay [s]	0.15	0.13	0.36	0.65	
d3, Initial Queue Delay [s]	0.00	0.00	0.00	0.00	
Rp, platoon ratio	1.00	1.00	1.00	1.00	
PF, progression factor	1.00	1.00	1.00	1.00	

**Lane Group Results**

X, volume / capacity	0.61	0.57	0.63	0.71	
d, Delay for Lane Group [s/veh]	5.93	5.79	9.82	10.27	
Lane Group LOS	A	A	A	B	
Critical Lane Group	Yes	No	No	Yes	
50th-Percentile Queue Length [veh/ln]	0.77	0.45	0.65	0.61	
50th-Percentile Queue Length [ft/ln]	19.20	11.28	16.13	15.30	
95th-Percentile Queue Length [veh/ln]	1.38	0.81	1.16	1.10	
95th-Percentile Queue Length [ft/ln]	34.55	20.30	29.03	27.53	

**Movement, Approach, & Intersection Results**

d_M, Delay for Movement [s/veh]	0.00	5.93	0.00	0.00	5.79	0.00	9.82	0.00	10.27	0.00	0.00	0.00
Movement LOS		A			A		A		B			
d_A, Approach Delay [s/veh]	5.93		5.79		10.04		0.00					
Approach LOS	A		A		B		A					
d_I, Intersection Delay [s/veh]	7.16											
Intersection LOS	A											
Intersection V/C	0.602											

**Emissions**

Vehicle Miles Traveled [mph]	156.83	84.27	48.34	43.81	
Stops [stops/h]	218.88	128.60	183.88	174.41	
Fuel consumption [US gal/h]	8.77	5.29	4.06	3.77	
CO [g/h]	612.72	370.02	283.59	263.50	
NOx [g/h]	119.21	71.99	55.18	51.27	
VOC [g/h]	142.00	85.76	65.73	61.07	

**Other Modes**

g_Walk,mi, Effective Walk Time [s]	0.0	0.0	0.0	-5.8
M_corner, Corner Circulation Area [ft <sup>2</sup> /ped]	0.00	0.00	0.00	0.00
M_CW, Crosswalk Circulation Area [ft <sup>2</sup> /ped]	0.00	0.00	0.00	0.00
d_p, Pedestrian Delay [s]	0.00	0.00	0.00	19.09
I_p,int, Pedestrian LOS Score for Intersectio	0.000	0.000	0.000	1.690
Crosswalk LOS	F	F	F	A
s_b, Saturation Flow Rate of the bicycle lane	2000	2000	2000	2000
c_b, Capacity of the bicycle lane [bicycles/h]	3167	3167	2059	0
d_b, Bicycle Delay [s]	4.30	4.30	0.01	12.63
I_b,int, Bicycle LOS Score for Intersection	2.311	2.267	1.560	4.132
Bicycle LOS	B	B	A	D

**Sequence**

Ring 1	-	2	-	4	-	-	-	-	-	-	-	-	-	-	-
Ring 2	-	6	-	-	-	-	-	-	-	-	-	-	-	-	-
Ring 3	-	-	-	-	-	-	-	-	-	-	-	-	-	-	-
Ring 4	-	-	-	-	-	-	-	-	-	-	-	-	-	-	-



**Intersection Level Of Service Report**  
**Intersection 13: El Charro Road & Jack London Boulevard**

Control Type:	Signalized	Delay (sec / veh):	13.9
Analysis Method:	HCM 7th Edition	Level Of Service:	B
Analysis Period:	15 minutes	Volume to Capacity (v/c):	0.719

**Intersection Setup**

Name	El Charro Road			El Charro Road			Stoneridge Drive			Jack London Boulevard		
Approach	Northbound			Southbound			Eastbound			Westbound		
Lane Configuration	TUT			TUT			TUT			TUT		
Turning Movement	Left	Thru	Right	Left	Thru	Right	Left	Thru	Right	Left	Thru	Right
Lane Width [ft]	12.00	12.00	12.00	12.00	12.00	12.00	12.00	12.00	12.00	12.00	12.00	12.00
No. of Lanes in Entry Pocket	1	0	2	2	0	1	3	0	1	1	0	2
Entry Pocket Length [ft]	125.00	100.00	175.00	650.00	100.00	450.00	450.00	100.00	325.00	400.00	100.00	775.00
No. of Lanes in Exit Pocket	0	0	0	0	0	2	1	0	0	0	0	0
Exit Pocket Length [ft]	0.00	0.00	0.00	0.00	0.00	100.00	450.00	0.00	0.00	0.00	0.00	0.00
Speed [mph]	30.00			30.00			30.00			30.00		
Grade [%]	0.00			0.00			0.00			0.00		
Curb Present	Yes			Yes			Yes			Yes		
Crosswalk	Yes			No			Yes			Yes		



**Volumes**

Name	El Charro Road			El Charro Road			Stoneridge Drive			Jack London Boulevard		
Base Volume Input [veh/h]	34	102	77	734	77	388	613	432	52	29	168	650
Base Volume Adjustment Factor	1.0000	1.0000	1.0000	1.0000	1.0000	1.0000	1.0000	1.0000	1.0000	1.0000	1.0000	1.0000
Heavy Vehicles Percentage [%]	0.00	20.00	0.00	0.30	44.40	0.80	0.50	0.50	0.00	0.00	1.80	0.60
Proportion of CAVs [%]	0.00											
Growth Factor	1.0000	1.0000	1.0000	1.0000	1.0000	1.0000	1.0000	1.0000	1.0000	1.0000	1.0000	1.0000
In-Process Volume [veh/h]	0	0	0	0	0	0	0	0	0	0	0	0
Site-Generated Trips [veh/h]	0	0	0	0	0	0	0	0	0	0	0	0
Diverted Trips [veh/h]	0	0	0	0	0	0	0	0	0	0	0	0
Pass-by Trips [veh/h]	0	0	0	0	0	0	0	0	0	0	0	0
Existing Site Adjustment Volume [veh/h]	0	0	0	0	0	0	0	0	0	0	0	0
Other Volume [veh/h]	0	0	0	0	0	0	0	0	0	0	0	0
Right Turn on Red Volume [veh/h]	0	0	0	0	0	0	0	0	0	0	0	0
Total Hourly Volume [veh/h]	34	102	77	734	77	388	613	432	52	29	168	650
Peak Hour Factor	0.9200	0.9200	0.9200	0.9200	0.9200	0.9200	0.9200	0.9200	0.9200	0.9200	0.9200	0.9200
Other Adjustment Factor	1.0000	1.0000	1.0000	1.0000	1.0000	1.0000	1.0000	1.0000	1.0000	1.0000	1.0000	1.0000
Total 15-Minute Volume [veh/h]	9	28	21	199	21	105	167	117	14	8	46	177
Total Analysis Volume [veh/h]	37	111	84	798	84	422	666	470	57	32	183	707
Presence of On-Street Parking	No		No	No		No	No		No	No		No
On-Street Parking Maneuver Rate [/h]	0	0	0	0	0	0	0	0	0	0	0	0
Local Bus Stopping Rate [/h]	0	0	0	0	0	0	0	0	0	0	0	0
v_do, Outbound Pedestrian Volume crossing	0			0			0			0		
v_di, Inbound Pedestrian Volume crossing m	0			0			0			0		
v_co, Outbound Pedestrian Volume crossing	0			0			0			0		
v_ci, Inbound Pedestrian Volume crossing mi	0			0			0			0		
v_ab, Corner Pedestrian Volume [ped/h]	0			0			0			0		
Bicycle Volume [bicycles/h]	0			0			0			0		



**Intersection Settings**

Located in CBD	No
Signal Coordination Group	-
Cycle Length [s]	90
Active Pattern	Free Running (No Pattern)
Coordination Type	<i>Free Running</i>
Actuation Type	<i>Fully actuated</i>
Offset [s]	0.0
Offset Reference	Lead Green - Beginning of First Green
Permissive Mode	SingleBand
Lost time [s]	12.00

**Phasing & Timing (Basic)**

Control Type	ProtPer	Permiss	Permiss	Protecte	Permiss	Permiss	ProtPer	Permiss	Permiss	ProtPer	Permiss	Overlap
Signal Group	7	4	0	3	8	0	1	6	0	5	2	2
Auxiliary Signal Groups												2,3
Maximum Green [s]	5	25	0	35	20	0	4	25	0	7	20	20
Amber [s]	3.0	5.0	0.0	3.0	4.3	0.0	3.0	4.3	0.0	3.0	4.3	4.3
All red [s]	1.0	1.0	0.0	1.0	1.0	0.0	1.0	1.0	0.0	1.0	1.0	1.0
Walk [s]	0	5	0	0	5	0	0	5	0	0	0	0
Pedestrian Clearance [s]	0	28	0	0	28	0	0	30	0	0	0	0
Delayed Vehicle Green [s]	0.0	0.0	0.0	0.0	0.0	0.0	0.0	0.0	0.0	0.0	0.0	0.0
Rest In Walk		No			No			No			No	
I1, Start-Up Lost Time [s]	2.0	2.0	0.0	2.0	2.0	0.0	2.0	2.0	0.0	2.0	2.0	2.0
I2, Clearance Lost Time [s]	2.0	2.0	0.0	2.0	2.0	0.0	2.0	2.0	0.0	2.0	2.0	2.0
Detector Location [ft]	0.0	0.0	0.0	0.0	0.0	0.0	0.0	0.0	0.0	0.0	0.0	0.0
Detector Length [ft]	0.0	0.0	0.0	0.0	0.0	0.0	0.0	0.0	0.0	0.0	0.0	0.0
I, Upstream Filtering Factor	1.00	1.00	1.00	1.00	1.00	1.00	1.00	1.00	1.00	1.00	1.00	1.00

**Phasing & Timing: Free Running (No Pattern)**

Split [s]	0	0	0	0	0	0	0	0	0	0	0	0
Lead / Lag	Lead	-	-	Lead	-	-	Lead	-	-	Lead	-	-
Minimum Green [s]	4	5	0	7	5	0	5	4	0	4	7	7
Vehicle Extension [s]	2.0	2.5	0.0	2.5	2.5	0.0	2.0	3.0	0.0	2.0	3.0	3.0
Minimum Recall	Yes	No		No	No		Yes	Yes		Yes	Yes	Yes
Maximum Recall	No	No		No	No		No	No		No	No	No
Pedestrian Recall	No	No		No	No		No	No		No	No	No

**Exclusive Pedestrian Phase**

Pedestrian Signal Group	0
Pedestrian Walk [s]	0
Pedestrian Clearance [s]	0



**Lane Group Calculations**

Lane Group	L	C	C	L	C	R	L	C	R	L	C	R
C, Cycle Length [s]	50	50	50	50	50	50	50	50	50	50	50	50
L, Total Lost Time per Cycle [s]	4.00	4.00	4.00	4.00	4.00	4.00	4.00	4.00	4.00	4.00	4.00	4.00
l1_p, Permitted Start-Up Lost Time [s]	0.00	0.00	0.00	0.00	0.00	0.00	0.00	0.00	0.00	0.00	0.00	0.00
l2, Clearance Lost Time [s]	0.00	2.00	2.00	2.00	2.00	2.00	0.00	2.00	2.00	0.00	2.00	0.00
g_i, Effective Green Time [s]	25	7	7	14	19	19	17	11	11	17	9	27
g / C, Green / Cycle	0.50	0.14	0.14	0.28	0.39	0.39	0.34	0.23	0.23	0.34	0.18	0.54
(v / s)_i Volume / Saturation Flow Rate	0.04	0.04	0.06	0.15	0.07	0.26	0.22	0.13	0.04	0.03	0.05	0.25
s, saturation flow rate [veh/h]	883	3046	1360	5259	1234	1605	3050	3603	1615	1078	3566	2845
c, Capacity [veh/h]	742	421	188	1495	481	625	1311	824	369	480	635	1543
d1, Uniform Delay [s]	7.48	19.30	19.82	15.12	10.01	12.65	13.64	17.13	15.44	12.40	17.83	6.98
k, delay calibration	0.08	0.08	0.08	0.08	0.08	0.16	0.14	0.11	0.11	0.11	0.11	0.11
l, Upstream Filtering Factor	1.00	1.00	1.00	1.00	1.00	1.00	1.00	1.00	1.00	1.00	1.00	1.00
d2, Incremental Delay [s]	0.02	0.25	1.23	0.22	0.13	1.92	0.39	0.62	0.19	0.06	0.25	0.21
d3, Initial Queue Delay [s]	0.00	0.00	0.00	0.00	0.00	0.00	0.00	0.00	0.00	0.00	0.00	0.00
Rp, platoon ratio	1.00	1.00	1.00	1.00	1.00	1.00	1.00	1.00	1.00	1.00	1.00	1.00
PF, progression factor	1.00	1.00	1.00	1.00	1.00	1.00	1.00	1.00	1.00	1.00	1.00	1.00

**Lane Group Results**

X, volume / capacity	0.05	0.26	0.45	0.53	0.17	0.67	0.51	0.57	0.15	0.07	0.29	0.46
d, Delay for Lane Group [s/veh]	7.50	19.54	21.05	15.34	10.13	14.57	14.03	17.75	15.63	12.46	18.08	7.19
Lane Group LOS	A	B	C	B	B	B	B	B	B	B	B	A
Critical Lane Group	Yes	No	No	No	No	Yes	Yes	No	No	No	No	Yes
50th-Percentile Queue Length [veh/ln]	0.18	0.54	0.88	2.24	0.52	3.53	1.74	2.18	0.48	0.22	0.84	1.68
50th-Percentile Queue Length [ft/ln]	4.42	13.41	21.90	55.94	12.99	88.18	43.53	54.58	12.04	5.62	21.09	41.96
95th-Percentile Queue Length [veh/ln]	0.32	0.97	1.58	4.03	0.94	6.35	3.13	3.93	0.87	0.40	1.52	3.02
95th-Percentile Queue Length [ft/ln]	7.96	24.15	39.43	100.69	23.39	158.73	78.36	98.25	21.66	10.11	37.97	75.53



**Movement, Approach, & Intersection Results**

d_M, Delay for Movement [s/veh]	7.50	19.54	21.05	15.34	10.13	14.57	14.03	17.75	15.63	12.46	18.08	7.19
Movement LOS	A	B	C	B	B	B	B	B	B	B	B	A
d_A, Approach Delay [s/veh]	18.17			14.76			15.58			9.54		
Approach LOS	B			B			B			A		
d_I, Intersection Delay [s/veh]	13.92											
Intersection LOS	B											
Intersection V/C	0.719											

**Emissions**

Vehicle Miles Traveled [mph]	2.35	7.04	5.33	137.38	14.46	72.65	85.02	60.00	7.28	5.56	31.79	122.83
Stops [stops/h]	12.76	77.42	63.21	484.25	37.50	254.47	376.85	315.00	34.73	16.21	121.74	242.17
Fuel consumption [US gal/h]	0.22	1.16	0.93	10.82	0.98	5.65	7.48	5.91	0.67	0.40	2.65	7.43
CO [g/h]	15.63	81.03	64.91	756.50	68.20	394.80	523.15	413.02	47.03	27.93	185.56	519.33
NOx [g/h]	3.04	15.77	12.63	147.19	13.27	76.81	101.79	80.36	9.15	5.43	36.10	101.04
VOC [g/h]	3.62	18.78	15.04	175.33	15.81	91.50	121.24	95.72	10.90	6.47	43.01	120.36

**Other Modes**

g_Walk,mi, Effective Walk Time [s]	9.0			0.0			9.0			9.0		
M_corner, Corner Circulation Area [ft <sup>2</sup> /ped]	0.00			0.00			0.00			0.00		
M_CW, Crosswalk Circulation Area [ft <sup>2</sup> /ped]	0.00			0.00			0.00			0.00		
d_p, Pedestrian Delay [s]	16.76			0.00			16.76			16.76		
I_p,int, Pedestrian LOS Score for Intersectio	2.361			0.000			3.041			2.973		
Crosswalk LOS	B			F			C			C		
s_b, Saturation Flow Rate of the bicycle lane	2000			2000			2000			2000		
c_b, Capacity of the bicycle lane [bicycles/h]	1002			802			1002			802		
d_b, Bicycle Delay [s]	6.21			8.96			6.21			8.96		
I_b,int, Bicycle LOS Score for Intersection	1.687			3.711			2.544			2.320		
Bicycle LOS	A			D			B			B		

**Sequence**

Ring 1	1	2	3	4	-	-	-	-	-	-	-	-	-	-	-
Ring 2	5	6	7	8	-	-	-	-	-	-	-	-	-	-	-
Ring 3	-	-	-	-	-	-	-	-	-	-	-	-	-	-	-
Ring 4	-	-	-	-	-	-	-	-	-	-	-	-	-	-	-



**Intersection Level Of Service Report**  
**Intersection 14: Central Parkway & Sunset View Drive**

Control Type:	Signalized	Delay (sec / veh):	11.2
Analysis Method:	HCM 7th Edition	Level Of Service:	B
Analysis Period:	15 minutes	Volume to Capacity (v/c):	0.260

**Intersection Setup**

Name	Driveway			Sunset View Drive			Central Parkway			Central Parkway		
Approach	Northbound			Southbound			Eastbound			Westbound		
Lane Configuration	↔			↔			↔↔			↔		
Turning Movement	Left	Thru	Right	Left	Thru	Right	Left	Thru	Right	Left	Thru	Right
Lane Width [ft]	12.00	12.00	12.00	12.00	12.00	12.00	12.00	12.00	12.00	12.00	12.00	12.00
No. of Lanes in Entry Pocket	1	0	0	0	0	1	1	0	1	1	0	0
Entry Pocket Length [ft]	250.00	100.00	100.00	100.00	100.00	85.00	225.00	100.00	800.00	150.00	100.00	100.00
No. of Lanes in Exit Pocket	0	0	0	0	0	0	0	0	0	0	0	0
Exit Pocket Length [ft]	0.00	0.00	0.00	0.00	0.00	0.00	0.00	0.00	0.00	0.00	0.00	0.00
Speed [mph]	30.00			30.00			30.00			30.00		
Grade [%]	0.00			0.00			0.00			0.00		
Curb Present	No			No			No			No		
Crosswalk	Yes			Yes			Yes			Yes		





**Volumes**

Name	Driveway			Sunset View Drive			Central Parkway			Central Parkway		
Base Volume Input [veh/h]	9	0	4	3	1	74	81	141	14	2	94	1
Base Volume Adjustment Factor	1.0000	1.0000	1.0000	1.0000	1.0000	1.0000	1.0000	1.0000	1.0000	1.0000	1.0000	1.0000
Heavy Vehicles Percentage [%]	0.00	0.00	0.00	0.00	0.00	0.00	0.00	0.00	0.00	0.00	0.00	0.00
Proportion of CAVs [%]	0.00											
Growth Factor	1.0000	1.0000	1.0000	1.0000	1.0000	1.0000	1.0000	1.0000	1.0000	1.0000	1.0000	1.0000
In-Process Volume [veh/h]	0	0	0	0	0	0	0	0	0	0	0	0
Site-Generated Trips [veh/h]	0	0	0	0	0	0	0	0	0	0	0	0
Diverted Trips [veh/h]	0	0	0	0	0	0	0	0	0	0	0	0
Pass-by Trips [veh/h]	0	0	0	0	0	0	0	0	0	0	0	0
Existing Site Adjustment Volume [veh/h]	0	0	0	0	0	0	0	0	0	0	0	0
Other Volume [veh/h]	0	0	0	0	0	0	0	0	0	0	0	0
Right Turn on Red Volume [veh/h]	0	0	0	0	0	0	0	0	0	0	0	0
Total Hourly Volume [veh/h]	9	0	4	3	1	74	81	141	14	2	94	1
Peak Hour Factor	0.9200	0.9200	0.9200	0.9200	0.9200	0.9200	0.9200	0.9200	0.9200	0.9200	0.9200	0.9200
Other Adjustment Factor	1.0000	1.0000	1.0000	1.0000	1.0000	1.0000	1.0000	1.0000	1.0000	1.0000	1.0000	1.0000
Total 15-Minute Volume [veh/h]	2	0	1	1	0	20	22	38	4	1	26	0
Total Analysis Volume [veh/h]	10	0	4	3	1	80	88	153	15	2	102	1
Presence of On-Street Parking	No		No	No		No	No		No	No		No
On-Street Parking Maneuver Rate [/h]	0	0	0	0	0	0	0	0	0	0	0	0
Local Bus Stopping Rate [/h]	0	0	0	0	0	0	0	0	0	0	0	0
v_do, Outbound Pedestrian Volume crossing	2			1			1			0		
v_di, Inbound Pedestrian Volume crossing m	1			0			2			1		
v_co, Outbound Pedestrian Volume crossing	0			0			0			0		
v_ci, Inbound Pedestrian Volume crossing mi	0			0			0			0		
v_ab, Corner Pedestrian Volume [ped/h]	0			0			0			0		
Bicycle Volume [bicycles/h]	0			0			1			0		



**Intersection Settings**

Located in CBD	No
Signal Coordination Group	-
Cycle Length [s]	90
Active Pattern	Free Running (No Pattern)
Coordination Type	<i>Free Running</i>
Actuation Type	<i>Fully actuated</i>
Offset [s]	0.0
Offset Reference	Lead Green - Beginning of First Green
Permissive Mode	SingleBand
Lost time [s]	12.00

**Phasing & Timing (Basic)**

Control Type	Protecte	Permiss	Permiss	Protecte	Permiss	Permiss	Protecte	Permiss	Permiss	Protecte	Permiss	Permiss
Signal Group	3	8	0	7	4	0	5	2	0	1	6	0
Auxiliary Signal Groups												
Maximum Green [s]	30	30	0	20	20	0	20	25	0	20	25	0
Amber [s]	3.0	3.0	0.0	3.0	3.0	0.0	3.0	3.6	0.0	3.0	3.6	0.0
All red [s]	1.0	1.0	0.0	1.0	1.0	0.0	1.0	1.0	0.0	1.0	1.0	0.0
Walk [s]	0	4	0	0	4	0	0	4	0	0	4	0
Pedestrian Clearance [s]	0	24	0	0	21	0	0	16	0	0	17	0
Delayed Vehicle Green [s]	0.0	0.0	0.0	0.0	0.0	0.0	0.0	0.0	0.0	0.0	0.0	0.0
Rest In Walk		No			No			No			No	
I1, Start-Up Lost Time [s]	2.0	2.0	0.0	2.0	2.0	0.0	2.0	2.0	0.0	2.0	2.0	0.0
I2, Clearance Lost Time [s]	2.0	2.0	0.0	2.0	2.0	0.0	2.0	2.0	0.0	2.0	2.0	0.0
Detector Location [ft]	0.0	0.0	0.0	0.0	0.0	0.0	0.0	0.0	0.0	0.0	0.0	0.0
Detector Length [ft]	20.0	20.0	0.0	20.0	20.0	0.0	20.0	20.0	0.0	20.0	20.0	0.0
I, Upstream Filtering Factor	1.00	1.00	1.00	1.00	1.00	1.00	1.00	1.00	1.00	1.00	1.00	1.00

**Phasing & Timing: Free Running (No Pattern)**

Split [s]	9	14	0	9	14	0	9	14	0	9	14	0
Lead / Lag	Lead	-	-	Lead	-	-	Lead	-	-	Lead	-	-
Minimum Green [s]	5	10	0	5	10	0	5	10	0	5	10	0
Vehicle Extension [s]	2.0	4.0	0.0	2.0	4.0	0.0	2.0	4.0	0.0	2.0	4.0	0.0
Minimum Recall	No	No		No	No		No	Yes		No	Yes	
Maximum Recall	No	No		No	No		No	No		No	No	
Pedestrian Recall	No	No		No	No		No	No		No	No	

**Exclusive Pedestrian Phase**

Pedestrian Signal Group	0
Pedestrian Walk [s]	0
Pedestrian Clearance [s]	0



**Lane Group Calculations**

Lane Group	L	C	L	C	L	C	R	L	C
C, Cycle Length [s]	31	31	31	31	31	31	31	31	31
L, Total Lost Time per Cycle [s]	4.00	4.00	4.00	4.00	4.00	4.00	4.00	4.00	4.00
l1_p, Permitted Start-Up Lost Time [s]	0.00	0.00	0.00	0.00	0.00	0.00	0.00	0.00	0.00
l2, Clearance Lost Time [s]	2.00	2.00	2.00	2.00	2.00	2.00	2.00	2.00	2.00
g_i, Effective Green Time [s]	0	5	0	5	3	9	9	0	7
g / C, Green / Cycle	0.01	0.17	0.00	0.16	0.09	0.30	0.30	0.00	0.21
(v / s)_i Volume / Saturation Flow Rate	0.01	0.00	0.00	0.05	0.05	0.08	0.01	0.00	0.05
s, saturation flow rate [veh/h]	1810	1615	1810	1618	1810	1900	1573	1810	1897
c, Capacity [veh/h]	26	284	8	269	159	570	472	6	409
d1, Uniform Delay [s]	15.14	10.55	15.37	11.34	13.54	8.25	7.66	15.41	10.08
k, delay calibration	0.04	0.15	0.04	0.15	0.04	0.15	0.15	0.04	0.15
l, Upstream Filtering Factor	1.00	1.00	1.00	1.00	1.00	1.00	1.00	1.00	1.00
d2, Incremental Delay [s]	3.52	0.03	9.61	0.89	1.12	0.36	0.04	12.95	0.46
d3, Initial Queue Delay [s]	0.00	0.00	0.00	0.00	0.00	0.00	0.00	0.00	0.00
Rp, platoon ratio	1.00	1.00	1.00	1.00	1.00	1.00	1.00	1.00	1.00
PF, progression factor	1.00	1.00	1.00	1.00	1.00	1.00	1.00	1.00	1.00

**Lane Group Results**

X, volume / capacity	0.39	0.01	0.36	0.30	0.55	0.27	0.03	0.35	0.25
d, Delay for Lane Group [s/veh]	18.65	10.58	24.98	12.23	14.66	8.61	7.70	28.36	10.54
Lane Group LOS	B	B	C	B	B	A	A	C	B
Critical Lane Group	Yes	No	No	Yes	Yes	No	No	No	Yes
50th-Percentile Queue Length [veh/ln]	0.08	0.02	0.04	0.43	0.51	0.57	0.05	0.03	0.47
50th-Percentile Queue Length [ft/ln]	2.03	0.47	0.98	10.74	12.63	14.37	1.31	0.80	11.74
95th-Percentile Queue Length [veh/ln]	0.15	0.03	0.07	0.77	0.91	1.03	0.09	0.06	0.85
95th-Percentile Queue Length [ft/ln]	3.65	0.85	1.76	19.34	22.73	25.87	2.35	1.44	21.14

**Movement, Approach, & Intersection Results**

d_M, Delay for Movement [s/veh]	18.65	10.58	10.58	24.98	12.23	12.23	14.66	8.61	7.70	28.36	10.54	10.54
Movement LOS	B	B	B	C	B	B	B	A	A	C	B	B
d_A, Approach Delay [s/veh]	16.35			12.69			10.64			10.88		
Approach LOS	B			B			B			B		
d_I, Intersection Delay [s/veh]	11.24											
Intersection LOS	B											
Intersection V/C	0.260											

**Emissions**

Vehicle Miles Traveled [mph]	0.27	0.11	0.11	3.01	20.01	34.78	3.41	0.42	21.77
Stops [stops/h]	9.47	2.22	4.56	50.22	59.02	67.17	6.10	3.73	54.89
Fuel consumption [US gal/h]	0.10	0.03	0.05	0.60	1.41	2.07	0.20	0.05	1.42
CO [g/h]	7.09	1.77	3.15	42.15	98.72	144.76	13.81	3.46	99.30
NOx [g/h]	1.38	0.34	0.61	8.20	19.21	28.17	2.69	0.67	19.32
VOC [g/h]	1.64	0.41	0.73	9.77	22.88	33.55	3.20	0.80	23.01

**Other Modes**

g_Walk,mi, Effective Walk Time [s]	8.0	8.0	8.0	8.0
M_corner, Corner Circulation Area [ft <sup>2</sup> /ped]	0.00	0.00	0.00	0.00
M_CW, Crosswalk Circulation Area [ft <sup>2</sup> /ped]	0.00	0.00	0.00	0.00
d_p, Pedestrian Delay [s]	8.44	8.44	8.44	8.44
I_p,int, Pedestrian LOS Score for Intersectio	1.893	1.939	2.183	1.969
Crosswalk LOS	A	A	B	A
s_b, Saturation Flow Rate of the bicycle lane	2000	2000	2000	2000
c_b, Capacity of the bicycle lane [bicycles/h]	1948	1298	1623	1623
d_b, Bicycle Delay [s]	0.01	1.90	0.55	0.55
I_b,int, Bicycle LOS Score for Intersection	1.583	1.698	1.982	1.733
Bicycle LOS	A	A	A	A

**Sequence**

Ring 1	1	2	3	4	-	-	-	-	-	-	-	-	-	-	-
Ring 2	5	6	7	8	-	-	-	-	-	-	-	-	-	-	-
Ring 3	-	-	-	-	-	-	-	-	-	-	-	-	-	-	-
Ring 4	-	-	-	-	-	-	-	-	-	-	-	-	-	-	-



**Intersection Level Of Service Report**

**Intersection 15: Central Parkway & Panorama Drive/Pino Grande Road**

Control Type:	All-way stop	Delay (sec / veh):	8.0
Analysis Method:	HCM 7th Edition	Level Of Service:	A
Analysis Period:	15 minutes	Volume to Capacity (v/c):	0.146

**Intersection Setup**

Name	Pino Grande Road			Panorama Drive			Central Parkway			Central Parkway		
Approach	Northbound			Southbound			Eastbound			Westbound		
Lane Configuration	+			+			+			+		
Turning Movement	Left	Thru	Right	Left	Thru	Right	Left	Thru	Right	Left	Thru	Right
Lane Width [ft]	12.00	12.00	12.00	12.00	12.00	12.00	12.00	12.00	12.00	12.00	12.00	12.00
No. of Lanes in Entry Pocket	0	0	0	0	0	1	1	0	0	1	0	0
Entry Pocket Length [ft]	100.00	100.00	100.00	100.00	100.00	100.00	275.00	100.00	100.00	100.00	100.00	100.00
No. of Lanes in Exit Pocket	0	0	0	0	0	0	0	0	0	0	0	0
Exit Pocket Length [ft]	0.00	0.00	0.00	0.00	0.00	0.00	0.00	0.00	0.00	0.00	0.00	0.00
Speed [mph]	30.00			30.00			30.00			30.00		
Grade [%]	0.00			0.00			0.00			0.00		
Crosswalk	Yes			Yes			Yes			Yes		

**Volumes**

Name	Pino Grande Road			Panorama Drive			Central Parkway			Central Parkway		
Base Volume Input [veh/h]	10	0	0	1	0	65	95	42	10	0	27	6
Base Volume Adjustment Factor	1.0000	1.0000	1.0000	1.0000	1.0000	1.0000	1.0000	1.0000	1.0000	1.0000	1.0000	1.0000
Heavy Vehicles Percentage [%]	0.00	0.00	0.00	0.00	0.00	0.00	0.00	0.00	0.00	0.00	0.00	0.00
Growth Factor	1.0000	1.0000	1.0000	1.0000	1.0000	1.0000	1.0000	1.0000	1.0000	1.0000	1.0000	1.0000
In-Process Volume [veh/h]	0	0	0	0	0	0	0	0	0	0	0	0
Site-Generated Trips [veh/h]	0	0	0	0	0	0	0	0	0	0	0	0
Diverted Trips [veh/h]	0	0	0	0	0	0	0	0	0	0	0	0
Pass-by Trips [veh/h]	0	0	0	0	0	0	0	0	0	0	0	0
Existing Site Adjustment Volume [veh/h]	0	0	0	0	0	0	0	0	0	0	0	0
Other Volume [veh/h]	0	0	0	0	0	0	0	0	0	0	0	0
Total Hourly Volume [veh/h]	10	0	0	1	0	65	95	42	10	0	27	6
Peak Hour Factor	0.9400	0.9400	0.9400	0.9400	0.9400	0.9400	0.9400	0.9400	0.9400	0.9400	0.9400	0.9400
Other Adjustment Factor	1.0000	1.0000	1.0000	1.0000	1.0000	1.0000	1.0000	1.0000	1.0000	1.0000	1.0000	1.0000
Total 15-Minute Volume [veh/h]	3	0	0	0	0	17	25	11	3	0	7	2
Total Analysis Volume [veh/h]	11	0	0	1	0	69	101	45	11	0	29	6
Pedestrian Volume [ped/h]	2			3			2			4		



**Intersection Settings**

**Lanes**

Capacity per Entry Lane [veh/h]	685	656	840	690	787	747	766
Degree of Utilization, x	0.02	0.00	0.08	0.15	0.07	0.00	0.05

**Movement, Approach, & Intersection Results**

95th-Percentile Queue Length [veh]	0.05	0.00	0.27	0.51	0.23	0.00	0.14
95th-Percentile Queue Length [ft]	1.22	0.11	6.70	12.77	5.74	0.00	3.59
Approach Delay [s/veh]	8.34	7.38		8.39		7.63	
Approach LOS	A	A		A		A	
Intersection Delay [s/veh]	8.03						
Intersection LOS	A						



**Intersection Level Of Service Report**  
**Intersection 16: Airway Boulevard & N. Canyons Parkway**

Control Type:	Signalized	Delay (sec / veh):	25.1
Analysis Method:	HCM 7th Edition	Level Of Service:	C
Analysis Period:	15 minutes	Volume to Capacity (v/c):	0.618

**Intersection Setup**

Name	Airway Boulevard			Driveway			N. Canyons Parkway			N Canyons Parkway		
Approach	Northbound			Southbound			Eastbound			Westbound		
Lane Configuration	↑↑↑			+			↑			↑↑↑		
Turning Movement	Left	Thru	Right	Left	Thru	Right	Left	Thru	Right	Left	Thru	Right
Lane Width [ft]	12.00	12.00	12.00	12.00	12.00	12.00	12.00	12.00	12.00	12.00	12.00	12.00
No. of Lanes in Entry Pocket	0	0	0	0	0	0	0	0	0	1	0	1
Entry Pocket Length [ft]	100.00	100.00	100.00	100.00	100.00	100.00	100.00	100.00	100.00	110.00	100.00	195.00
No. of Lanes in Exit Pocket	0	0	0	0	0	0	0	0	0	0	0	0
Exit Pocket Length [ft]	0.00	0.00	0.00	0.00	0.00	0.00	0.00	0.00	0.00	0.00	0.00	0.00
Speed [mph]	40.00			30.00			40.00			40.00		
Grade [%]	0.00			0.00			0.00			0.00		
Curb Present	Yes			Yes			Yes			Yes		
Crosswalk	Yes			Yes			Yes			No		



**Volumes**

Name	Airway Boulevard			Driveway			N. Canyons Parkway			N Canyons Parkway		
Base Volume Input [veh/h]	121	39	602	2	8	2	0	387	273	759	33	9
Base Volume Adjustment Factor	1.0000	1.0000	1.0000	1.0000	1.0000	1.0000	1.0000	1.0000	1.0000	1.0000	1.0000	1.0000
Heavy Vehicles Percentage [%]	4.50	2.60	1.20	0.00	0.00	0.00	2.00	0.00	1.70	0.70	0.00	0.00
Proportion of CAVs [%]	0.00											
Growth Factor	1.0000	1.0000	1.0000	1.0000	1.0000	1.0000	1.0000	1.0000	1.0000	1.0000	1.0000	1.0000
In-Process Volume [veh/h]	0	0	0	0	0	0	0	0	0	0	0	0
Site-Generated Trips [veh/h]	0	0	0	0	0	0	0	0	0	0	0	0
Diverted Trips [veh/h]	0	0	0	0	0	0	0	0	0	0	0	0
Pass-by Trips [veh/h]	0	0	0	0	0	0	0	0	0	0	0	0
Existing Site Adjustment Volume [veh/h]	0	0	0	0	0	0	0	0	0	0	0	0
Other Volume [veh/h]	0	0	0	0	0	0	0	0	0	0	0	0
Right Turn on Red Volume [veh/h]	0	0	0	0	0	0	0	0	0	0	0	0
Total Hourly Volume [veh/h]	121	39	602	2	8	2	0	387	273	759	33	9
Peak Hour Factor	0.9300	0.9300	0.9300	0.9300	0.9300	0.9300	1.0000	0.9300	0.9300	0.9300	0.9300	0.9300
Other Adjustment Factor	1.0000	1.0000	1.0000	1.0000	1.0000	1.0000	1.0000	1.0000	1.0000	1.0000	1.0000	1.0000
Total 15-Minute Volume [veh/h]	33	10	162	1	2	1	0	104	73	204	9	2
Total Analysis Volume [veh/h]	130	42	647	2	9	2	0	416	294	816	35	10
Presence of On-Street Parking	No		No	No		No	No		No	No		No
On-Street Parking Maneuver Rate [/h]	0	0	0	0	0	0	0	0	0	0	0	0
Local Bus Stopping Rate [/h]	0	0	0	0	0	0	0	0	0	0	0	0
v_do, Outbound Pedestrian Volume crossing	2			0			1			0		
v_di, Inbound Pedestrian Volume crossing m	1			0			2			0		
v_co, Outbound Pedestrian Volume crossing	0			0			0			0		
v_ci, Inbound Pedestrian Volume crossing mi	0			0			0			0		
v_ab, Corner Pedestrian Volume [ped/h]	0			0			0			0		
Bicycle Volume [bicycles/h]	0			0			0			0		





**Intersection Settings**

Located in CBD	No
Signal Coordination Group	-
Cycle Length [s]	105
Active Pattern	Pattern 1
Coordination Type	Time of Day Pattern Coordinated
Actuation Type	Fully actuated
Offset [s]	100.0
Offset Reference	Lead Green - Beginning of First Green
Permissive Mode	SingleBand
Lost time [s]	12.00

**Phasing & Timing (Basic)**

Control Type	Split	Split	Overlap	Split	Split	Split	Permiss	Permiss	Permiss	Protecte	Permiss	Permiss
Signal Group	0	8	8	0	4	0	0	2	0	1	6	0
Auxiliary Signal Groups			1,8									
Maximum Green [s]	0	20	20	0	12	0	0	15	0	50	50	0
Amber [s]	0.0	3.2	3.2	0.0	3.0	0.0	0.0	5.0	0.0	5.0	5.0	0.0
All red [s]	0.0	1.0	1.0	0.0	1.0	0.0	0.0	1.0	0.0	1.0	1.0	0.0
Walk [s]	0	0	0	0	5	0	0	5	0	0	5	0
Pedestrian Clearance [s]	0	0	0	0	28	0	0	29	0	0	12	0
Delayed Vehicle Green [s]	0.0	0.0	0.0	0.0	0.0	0.0	0.0	0.0	0.0	0.0	0.0	0.0
Rest In Walk		No			No			No			No	
I1, Start-Up Lost Time [s]	0.0	2.0	2.0	0.0	2.0	0.0	0.0	2.0	0.0	2.0	2.0	0.0
I2, Clearance Lost Time [s]	0.0	2.0	2.0	0.0	2.0	0.0	0.0	2.0	0.0	2.0	2.0	0.0
Detector Location [ft]	0.0	0.0	0.0	0.0	0.0	0.0	0.0	0.0	0.0	0.0	0.0	0.0
Detector Length [ft]	0.0	20.0	20.0	0.0	20.0	0.0	0.0	20.0	0.0	20.0	20.0	0.0
I, Upstream Filtering Factor	1.00	1.00	1.00	1.00	1.00	1.00	1.00	1.00	1.00	1.00	1.00	1.00

**Phasing & Timing: Pattern 1**

Split [s]	0	22	22	0	20	0	0	33	0	30	63	0
Lead / Lag	-	-	-	-	-	-	-	-	-	Lead	-	-
Minimum Green [s]	0	4	4	0	3	0	0	10	0	3	7	0
Vehicle Extension [s]	0.0	2.0	2.0	0.0	2.0	0.0	0.0	2.0	0.0	2.0	2.0	0.0
Minimum Recall		No	No		No			No		No	Yes	
Maximum Recall		No	No		No			No		Yes	Yes	
Pedestrian Recall		No	No		No			No		No	No	

**Exclusive Pedestrian Phase**

Pedestrian Signal Group	0
Pedestrian Walk [s]	0
Pedestrian Clearance [s]	0



**Lane Group Calculations**

Lane Group	C	R	C	C	R	L	C	R
C, Cycle Length [s]	105	105	105	105	105	105	105	105
L, Total Lost Time per Cycle [s]	4.00	4.00	4.00	4.00	4.00	4.00	4.00	4.00
l1_p, Permitted Start-Up Lost Time [s]	0.00	0.00	0.00	0.00	0.00	0.00	0.00	0.00
l2, Clearance Lost Time [s]	2.00	0.00	2.00	2.00	2.00	2.00	2.00	2.00
g_i, Effective Green Time [s]	15	68	1	24	24	49	77	77
g / C, Green / Cycle	0.14	0.65	0.01	0.23	0.23	0.47	0.73	0.73
(v / s)_i Volume / Saturation Flow Rate	0.10	0.23	0.01	0.11	0.19	0.23	0.02	0.01
s, saturation flow rate [veh/h]	1793	2831	1836	3618	1587	3495	1900	1615
c, Capacity [veh/h]	258	1789	17	816	358	1638	1392	1183
d1, Uniform Delay [s]	42.56	9.23	51.91	35.58	38.61	19.34	3.83	3.78
k, delay calibration	0.04	0.50	0.04	0.04	0.20	0.50	0.50	0.50
l, Upstream Filtering Factor	1.00	1.00	1.00	1.00	1.00	1.00	1.00	1.00
d2, Incremental Delay [s]	1.11	0.57	22.97	0.18	8.25	1.09	0.03	0.01
d3, Initial Queue Delay [s]	0.00	0.00	0.00	0.00	0.00	0.00	0.00	0.00
Rp, platoon ratio	1.00	1.00	1.00	1.00	1.00	1.00	1.00	1.00
PF, progression factor	1.00	1.00	1.00	1.00	1.00	1.00	1.00	1.00

**Lane Group Results**

X, volume / capacity	0.67	0.36	0.77	0.51	0.82	0.50	0.03	0.01
d, Delay for Lane Group [s/veh]	43.67	9.80	74.88	35.76	46.86	20.42	3.86	3.79
Lane Group LOS	D	A	E	D	D	C	A	A
Critical Lane Group	No	Yes	Yes	No	Yes	Yes	No	No
50th-Percentile Queue Length [veh/ln]	4.20	3.24	0.45	4.55	7.76	6.71	0.17	0.05
50th-Percentile Queue Length [ft/ln]	104.92	81.09	11.22	113.63	194.03	167.77	4.29	1.23
95th-Percentile Queue Length [veh/ln]	7.55	5.84	0.81	8.04	12.33	10.96	0.31	0.09
95th-Percentile Queue Length [ft/ln]	188.86	145.96	20.20	201.05	308.25	273.98	7.72	2.21

**Movement, Approach, & Intersection Results**

d_M, Delay for Movement [s/veh]	43.67	43.67	9.80	74.88	74.88	74.88	0.00	35.76	46.86	20.42	3.86	3.79
Movement LOS	D	D	A	E	E	E		D	D	C	A	A
d_A, Approach Delay [s/veh]	16.91			74.88				40.36		19.55		
Approach LOS	B			E				D		B		
d_I, Intersection Delay [s/veh]	25.10											
Intersection LOS	C											
Intersection V/C	0.618											

**Emissions**

Vehicle Miles Traveled [mph]	20.42	76.83	0.45	27.12	19.16	66.74	2.86	0.82
Stops [stops/h]	143.88	222.40	15.39	311.65	266.07	460.12	5.88	1.68
Fuel consumption [US gal/h]	3.67	6.23	0.30	7.06	6.10	10.30	0.19	0.05
CO [g/h]	256.76	435.25	21.08	493.49	426.63	720.08	13.13	3.74
NOx [g/h]	49.96	84.68	4.10	96.01	83.01	140.10	2.55	0.73
VOC [g/h]	59.51	100.87	4.88	114.37	98.88	166.88	3.04	0.87

**Other Modes**

g_Walk,mi, Effective Walk Time [s]	9.0	9.0	9.0	0.0
M_corner, Corner Circulation Area [ft <sup>2</sup> /ped]	0.00	0.00	0.00	0.00
M_CW, Crosswalk Circulation Area [ft <sup>2</sup> /ped]	1355.33	0.00	0.00	0.00
d_p, Pedestrian Delay [s]	43.89	43.89	43.89	0.00
I_p,int, Pedestrian LOS Score for Intersectio	2.882	1.756	2.537	0.000
Crosswalk LOS	C	A	B	F
s_b, Saturation Flow Rate of the bicycle lane	2000	2000	2000	2000
c_b, Capacity of the bicycle lane [bicycles/h]	339	305	514	1086
d_b, Bicycle Delay [s]	36.21	37.72	28.98	10.98
I_b,int, Bicycle LOS Score for Intersection	2.911	1.581	2.145	2.980
Bicycle LOS	C	A	B	C

**Sequence**

Ring 1	1	2	4	8	-	-	-	-	-	-	-	-	-	-	-
Ring 2	-	6	-	-	-	-	-	-	-	-	-	-	-	-	-
Ring 3	-	-	-	-	-	-	-	-	-	-	-	-	-	-	-
Ring 4	-	-	-	-	-	-	-	-	-	-	-	-	-	-	-

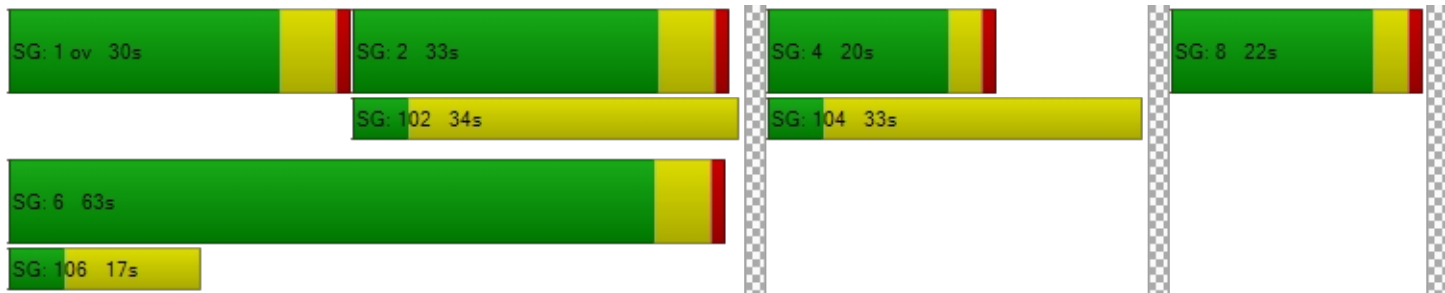

**Intersection Level Of Service Report**  
**Intersection 17: Airway Boulevard & I-580 WB Ramps**

Control Type:	Signalized	Delay (sec / veh):	9.0
Analysis Method:	HCM 7th Edition	Level Of Service:	A
Analysis Period:	15 minutes	Volume to Capacity (v/c):	0.251

**Intersection Setup**

Name	Airway Boulevard			Airway Boulevard			I-580 WB On-Ramp			I-580 WB Off-Ramp		
Approach	Northbound			Southbound			Eastbound			Westbound		
Lane Configuration	r			r						r rr		
Turning Movement	Left	Thru	Right	Left	Thru	Right	Left	Thru	Right	Left	Thru	Right
Lane Width [ft]	12.00	12.00	12.00	12.00	12.00	12.00	12.00	12.00	12.00	12.00	12.00	12.00
No. of Lanes in Entry Pocket	0	0	0	0	0	1	0	0	0	1	0	1
Entry Pocket Length [ft]	100.00	100.00	100.00	100.00	100.00	250.00	100.00	100.00	100.00	150.00	100.00	490.00
No. of Lanes in Exit Pocket	0	0	0	0	0	0	0	0	0	0	0	0
Exit Pocket Length [ft]	0.00	0.00	0.00	0.00	0.00	0.00	0.00	0.00	0.00	0.00	0.00	0.00
Speed [mph]	40.00			40.00			30.00			45.00		
Grade [%]	0.00			0.00			0.00			0.00		
Curb Present	Yes			Yes						Yes		
Crosswalk	No			No			No			Yes		



**Volumes**

Name	Airway Boulevard			Airway Boulevard			I-580 WB On-Ramp			I-580 WB Off-Ramp		
Base Volume Input [veh/h]	0	709	210	0	401	739	0	0	0	50	0	187
Base Volume Adjustment Factor	1.0000	1.0000	1.0000	1.0000	1.0000	1.0000	1.0000	1.0000	1.0000	1.0000	1.0000	1.0000
Heavy Vehicles Percentage [%]	2.00	1.20	0.00	2.00	0.40	0.70	2.00	2.00	2.00	0.00	0.00	1.10
Proportion of CAVs [%]	0.00											
Growth Factor	1.0000	1.0000	1.0000	1.0000	1.0000	1.0000	1.0000	1.0000	1.0000	1.0000	1.0000	1.0000
In-Process Volume [veh/h]	0	0	0	0	0	0	0	0	0	0	0	0
Site-Generated Trips [veh/h]	0	0	0	0	0	0	0	0	0	0	0	0
Diverted Trips [veh/h]	0	0	0	0	0	0	0	0	0	0	0	0
Pass-by Trips [veh/h]	0	0	0	0	0	0	0	0	0	0	0	0
Existing Site Adjustment Volume [veh/h]	0	0	0	0	0	0	0	0	0	0	0	0
Other Volume [veh/h]	0	0	0	0	0	0	0	0	0	0	0	0
Right Turn on Red Volume [veh/h]	0	0	0	0	0	0	0	0	0	0	0	0
Total Hourly Volume [veh/h]	0	709	210	0	401	739	0	0	0	50	0	187
Peak Hour Factor	1.0000	0.8900	0.8900	1.0000	0.8900	0.8900	1.0000	1.0000	1.0000	0.8900	0.8900	0.8900
Other Adjustment Factor	1.0000	1.0000	1.0000	1.0000	1.0000	1.0000	1.0000	1.0000	1.0000	1.0000	1.0000	1.0000
Total 15-Minute Volume [veh/h]	0	199	59	0	113	208	0	0	0	14	0	53
Total Analysis Volume [veh/h]	0	797	236	0	451	830	0	0	0	56	0	210
Presence of On-Street Parking	No		No	No		No				No		No
On-Street Parking Maneuver Rate [/h]	0	0	0	0	0	0	0	0	0	0	0	0
Local Bus Stopping Rate [/h]	0	0	0	0	0	0	0	0	0	0	0	0
v_do, Outbound Pedestrian Volume crossing	0			0			0			0		
v_di, Inbound Pedestrian Volume crossing m	0			0			0			0		
v_co, Outbound Pedestrian Volume crossing	0			0			0			0		
v_ci, Inbound Pedestrian Volume crossing mi	0			0			0			0		
v_ab, Corner Pedestrian Volume [ped/h]	0			0			0			0		
Bicycle Volume [bicycles/h]	1			0			0			0		



**Intersection Settings**

Located in CBD	No
Signal Coordination Group	-
Cycle Length [s]	105
Active Pattern	Pattern 1
Coordination Type	Time of Day Pattern Coordinated
Actuation Type	Fully actuated
Offset [s]	35.0
Offset Reference	Lead Green - Beginning of First Green
Permissive Mode	SingleBand
Lost time [s]	9.00

**Phasing & Timing (Basic)**

Control Type	Permiss	Permiss	Unsigna	Permiss	Permiss	Unsigna	Permiss	Permiss	Permiss	Permiss	Permiss	Overlap
Signal Group	0	2	0	0	6	0	0	0	0	0	8	1
Auxiliary Signal Groups												1,8
Maximum Green [s]	0	30	0	0	25	0	0	0	0	0	20	12
Amber [s]	0.0	4.3	0.0	0.0	4.3	0.0	0.0	0.0	0.0	0.0	3.0	3.0
All red [s]	0.0	1.0	0.0	0.0	1.0	0.0	0.0	0.0	0.0	0.0	1.0	0.0
Walk [s]	0	7	0	0	0	0	0	0	0	0	0	0
Pedestrian Clearance [s]	0	15	0	0	0	0	0	0	0	0	0	0
Delayed Vehicle Green [s]	0.0	0.0	0.0	0.0	0.0	0.0	0.0	0.0	0.0	0.0	0.0	0.0
Rest In Walk		No			No						No	
I1, Start-Up Lost Time [s]	0.0	2.0	0.0	0.0	2.0	0.0	0.0	0.0	0.0	0.0	2.0	2.0
I2, Clearance Lost Time [s]	0.0	2.0	0.0	0.0	2.0	0.0	0.0	0.0	0.0	0.0	2.0	2.0
Detector Location [ft]	0.0	0.0	0.0	0.0	0.0	0.0	0.0	0.0	0.0	0.0	0.0	0.0
Detector Length [ft]	0.0	20.0	0.0	0.0	20.0	0.0	0.0	0.0	0.0	0.0	20.0	20.0
I, Upstream Filtering Factor	1.00	1.00	1.00	1.00	1.00	1.00	1.00	1.00	1.00	1.00	1.00	1.00

**Phasing & Timing: Pattern 1**

Split [s]	0	68	0	0	83	0	0	0	0	0	22	15
Lead / Lag	-	-	-	-	-	-	-	-	-	-	-	-
Minimum Green [s]	0	11	0	0	8	0	0	0	0	0	4	4
Vehicle Extension [s]	0.0	0.0	0.0	0.0	0.0	0.0	0.0	0.0	0.0	0.0	0.0	0.0
Minimum Recall		Yes			Yes						No	No
Maximum Recall		No			No						No	No
Pedestrian Recall		No			No						No	No

**Exclusive Pedestrian Phase**

Pedestrian Signal Group	0
Pedestrian Walk [s]	0
Pedestrian Clearance [s]	0



**Lane Group Calculations**

Lane Group	C	C		L	C	R
C, Cycle Length [s]	105	105		105	105	105
L, Total Lost Time per Cycle [s]	4.00	4.00		4.00	4.00	4.00
l1_p, Permitted Start-Up Lost Time [s]	0.00	0.00		0.00	0.00	0.00
l2, Clearance Lost Time [s]	2.00	2.00		2.00	2.00	0.00
g_i, Effective Green Time [s]	77	88		9	9	20
g / C, Green / Cycle	0.73	0.84		0.08	0.08	0.19
(v / s)_i Volume / Saturation Flow Rate	0.22	0.09		0.02	0.02	0.07
s, saturation flow rate [veh/h]	3583	5159		1810	1810	2834
c, Capacity [veh/h]	2617	4339		150	150	575
d1, Uniform Delay [s]	4.91	1.45		44.82	44.82	35.97
k, delay calibration	0.50	0.50		0.04	0.04	0.04
l, Upstream Filtering Factor	1.00	1.00		1.00	1.00	1.00
d2, Incremental Delay [s]	0.30	0.05		0.22	0.22	0.14
d3, Initial Queue Delay [s]	0.00	0.00		0.00	0.00	0.00
Rp, platoon ratio	1.00	1.00		1.00	1.00	1.00
PF, progression factor	1.00	1.00		1.00	1.00	1.00

**Lane Group Results**

X, volume / capacity	0.30	0.10		0.19	0.19	0.36
d, Delay for Lane Group [s/veh]	5.21	1.50		45.04	45.04	36.11
Lane Group LOS	A	A		D	D	D
Critical Lane Group	Yes	No		No	No	Yes
50th-Percentile Queue Length [veh/ln]	2.43	0.23		0.67	0.67	2.24
50th-Percentile Queue Length [ft/ln]	60.79	5.82		16.71	16.71	56.03
95th-Percentile Queue Length [veh/ln]	4.38	0.42		1.20	1.20	4.03
95th-Percentile Queue Length [ft/ln]	109.42	10.47		30.07	30.07	100.85

**Movement, Approach, & Intersection Results**

d_M, Delay for Movement [s/veh]	0.00	5.21	0.00	0.00	1.50	0.00	0.00	0.00	0.00	0.00	45.04	45.04	36.11
Movement LOS		A			A						D	D	D
d_A, Approach Delay [s/veh]	4.12				0.57				0.00		37.99		
Approach LOS	A				A				A		D		
d_I, Intersection Delay [s/veh]	9.02												
Intersection LOS	A												
Intersection V/C	0.251												

**Emissions**

Vehicle Miles Traveled [mph]	66.48	53.55	2.75	2.75	20.65
Stops [stops/h]	166.83	23.96	22.93	22.93	153.76
Fuel consumption [US gal/h]	4.87	2.29	0.64	0.64	4.16
CO [g/h]	340.10	160.16	44.46	44.46	291.00
NOx [g/h]	66.17	31.16	8.65	8.65	56.62
VOC [g/h]	78.82	37.12	10.30	10.30	67.44

**Other Modes**

g_Walk,mi, Effective Walk Time [s]	0.0	0.0	0.0	11.0
M_corner, Corner Circulation Area [ft <sup>2</sup> /ped]	0.00	0.00	0.00	0.00
M_CW, Crosswalk Circulation Area [ft <sup>2</sup> /ped]	0.00	0.00	0.00	0.00
d_p, Pedestrian Delay [s]	0.00	0.00	0.00	42.05
I_p,int, Pedestrian LOS Score for Intersectio	0.000	0.000	0.000	2.385
Crosswalk LOS	F	F	F	B
s_b, Saturation Flow Rate of the bicycle lane	2000	2000	2000	2000
c_b, Capacity of the bicycle lane [bicycles/h]	1195	1481	0	343
d_b, Bicycle Delay [s]	8.51	3.54	52.47	36.01
I_b,int, Bicycle LOS Score for Intersection	2.217	1.808	4.132	1.999
Bicycle LOS	B	A	D	A

**Sequence**

Ring 1	1	2	-	-	-	-	-	-	-	-	-	-	-	-	-
Ring 2	-	6	-	8	-	-	-	-	-	-	-	-	-	-	-
Ring 3	-	-	-	-	-	-	-	-	-	-	-	-	-	-	-
Ring 4	-	-	-	-	-	-	-	-	-	-	-	-	-	-	-







## Appendix F: Near-Term Plus Project Volume & Geometry

Lane Configuration and Traffic Control

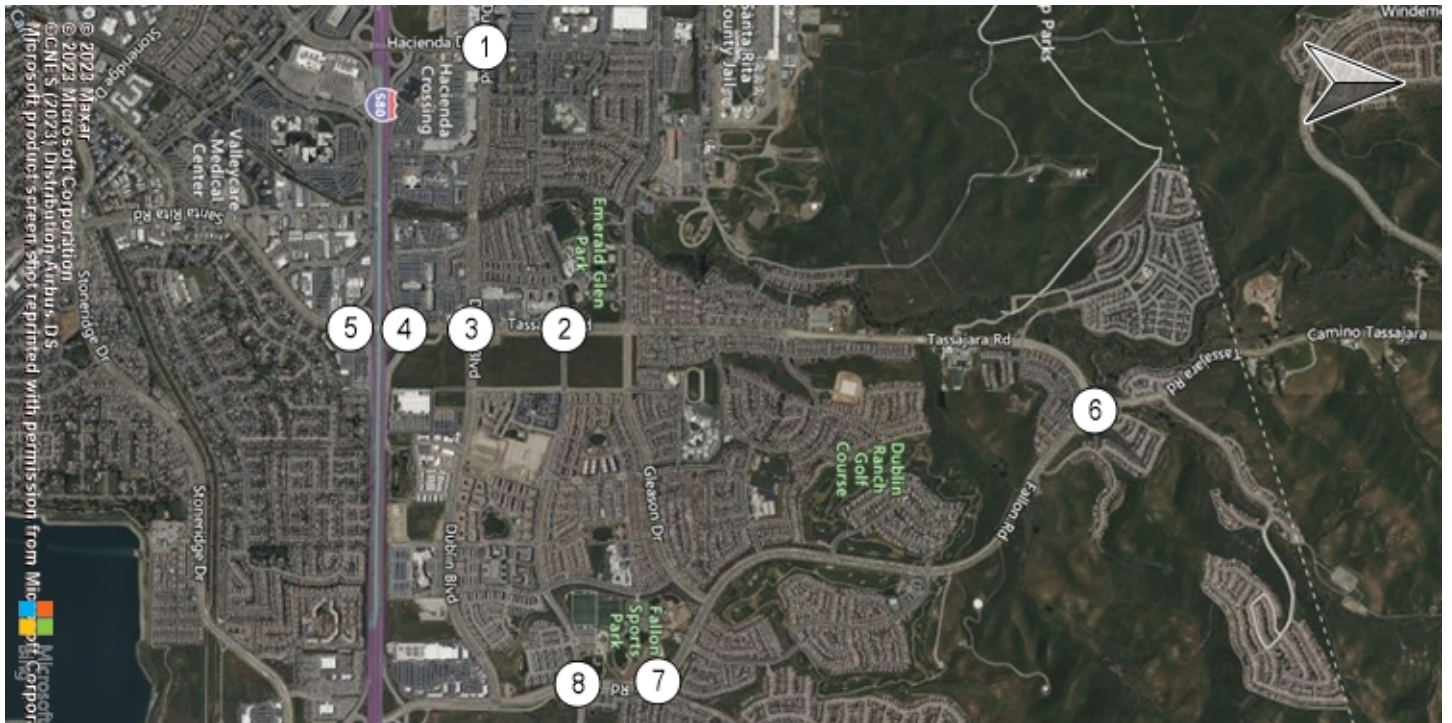

Hacienda Drive & Dublin Blvd Tassajara Road & Central Parkway Tassajara Road & Dublin Boulevard Tassajara Road & I-580 WB

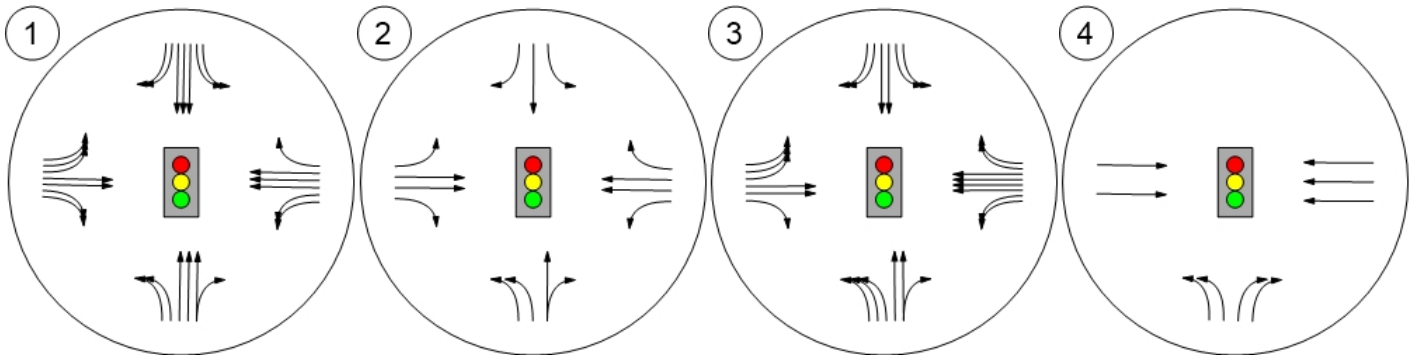

Santa Rita Rd & I-580 EB Ra Tassajara Road & Fallon Road Fallon Road & Positano Park Fallon Road & Central Parkway

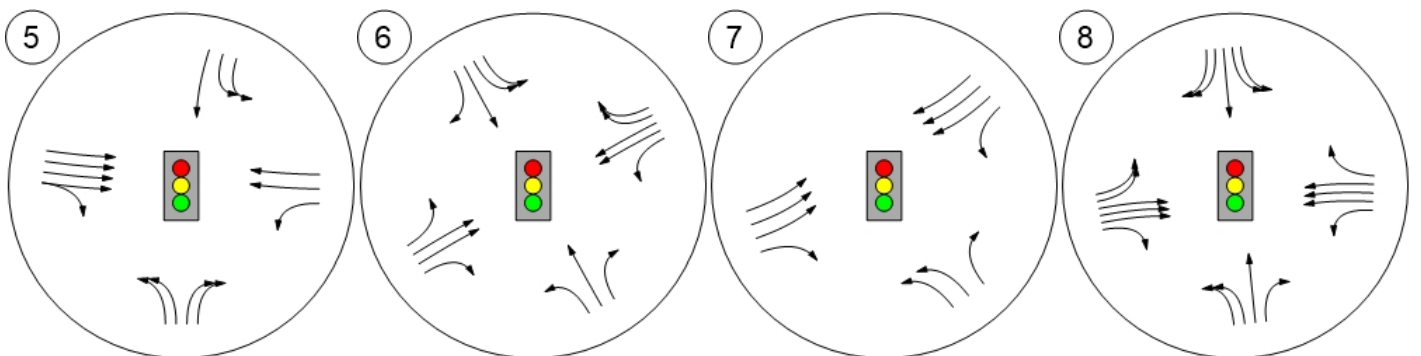

### Lane Configuration and Traffic Control

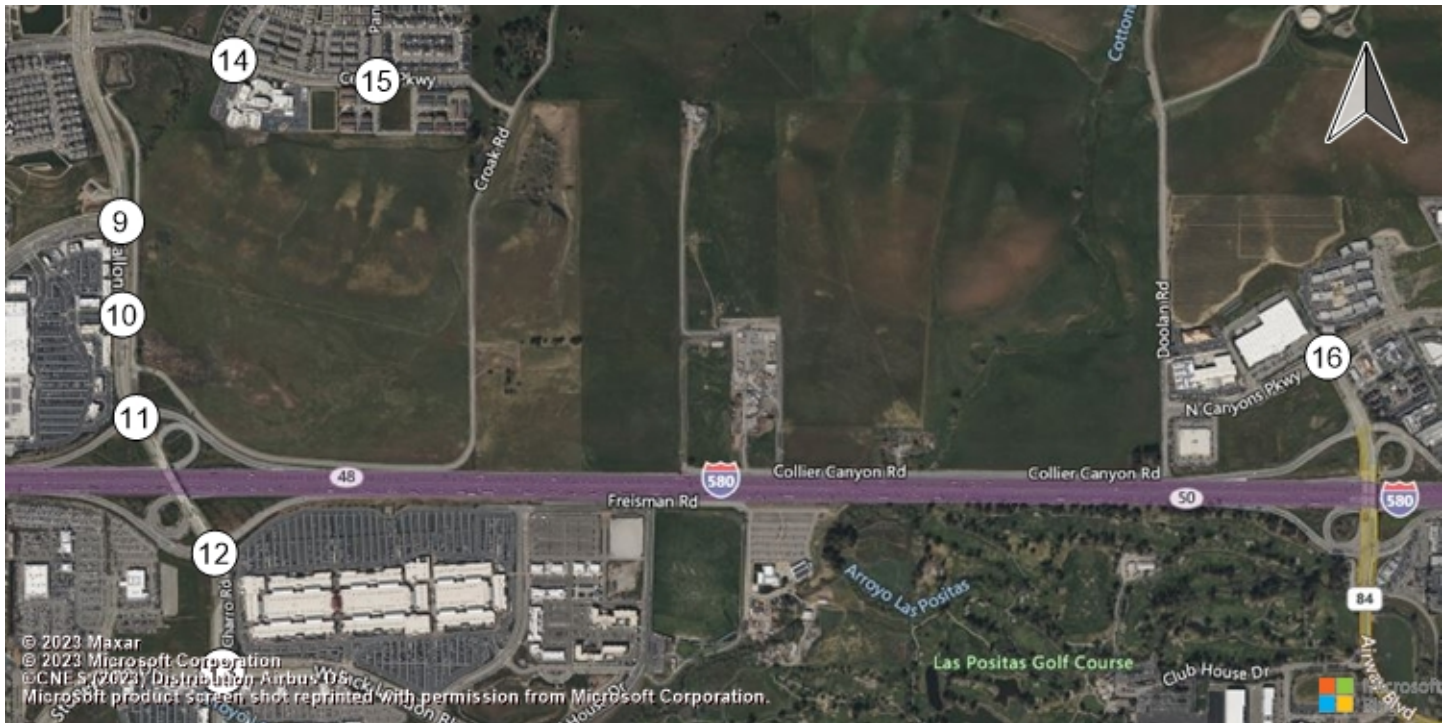

Fallon Road & Dublin Boulevard Fallon Road & Fallon Gateway Fallon Road & I-580 WB Ramp El Charro Road & I-580 EB R

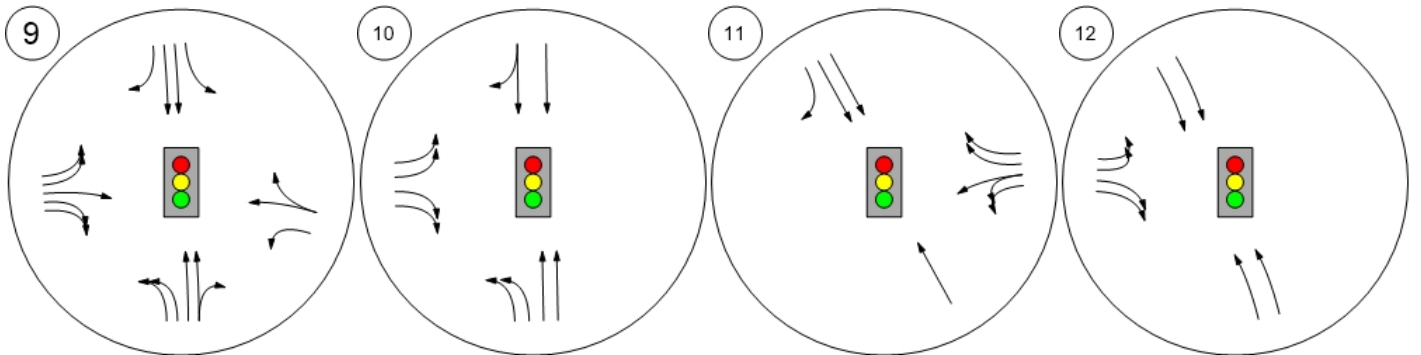

El Charro Road & Jack Lond Central Parkway & Sunset Vi Central Parkway & Panorama Airway Boulevard & N. Canyon

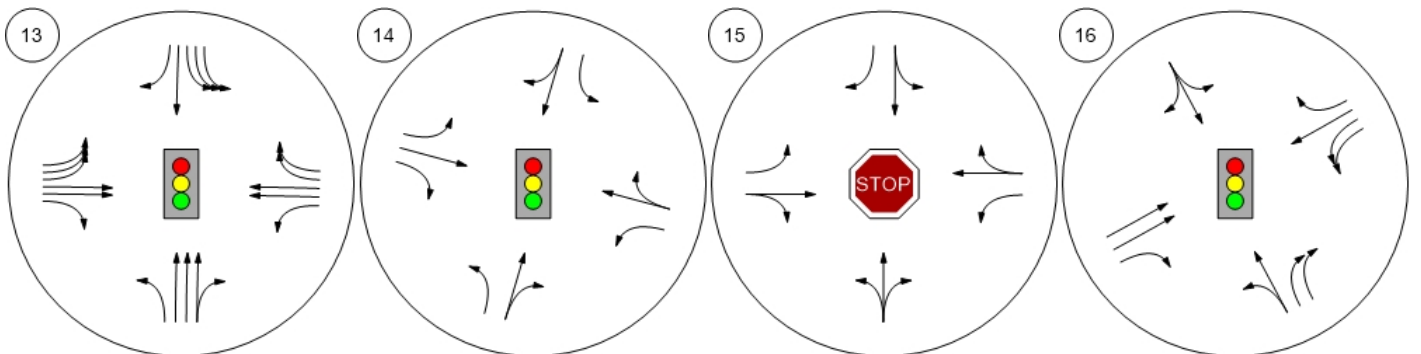



### Lane Configuration and Traffic Control

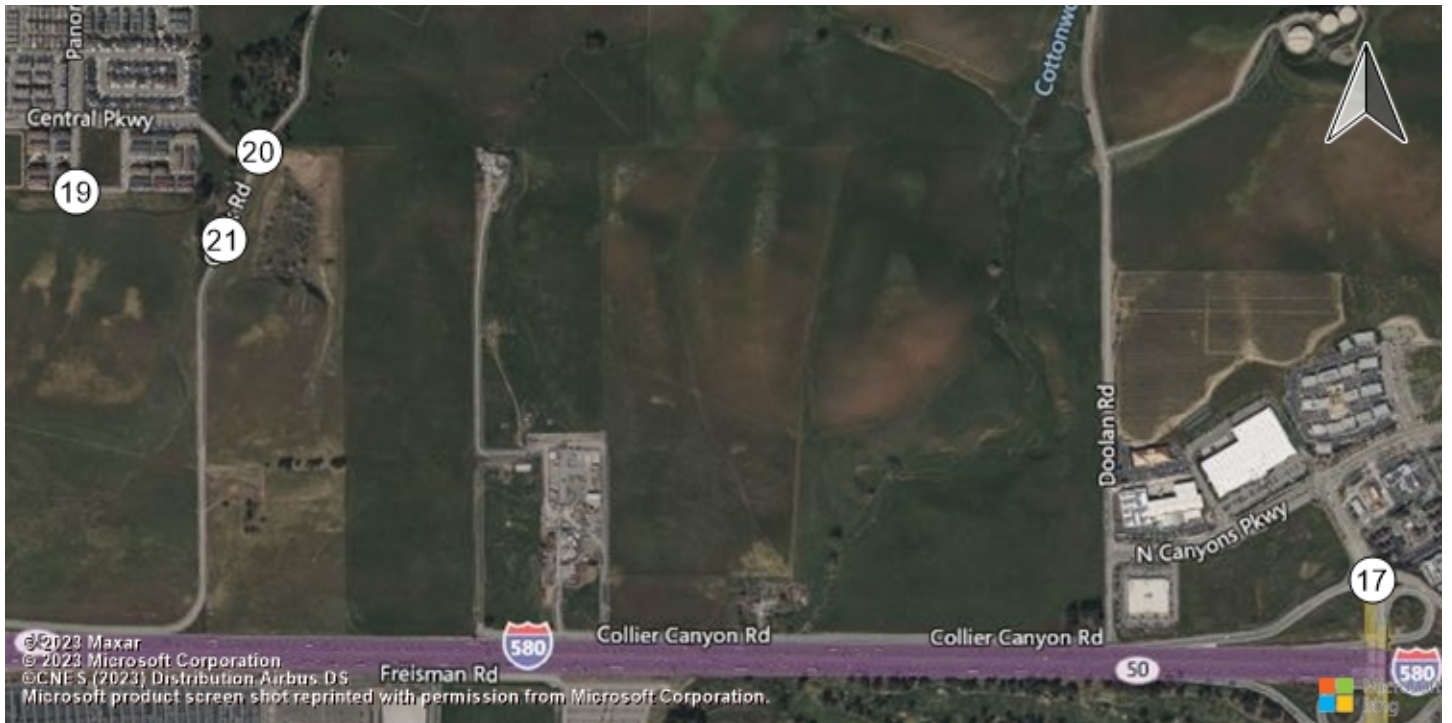

### Airway Boulevard & I-580 WB Pandora Way & Residential P Croak Road & Central Parkw Croak Road & Project Access

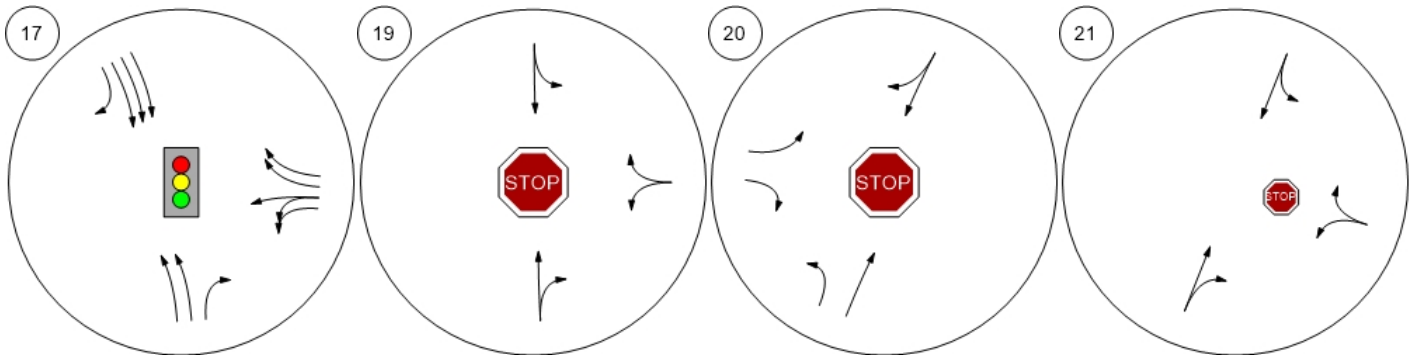

Traffic Volume - Base Volume

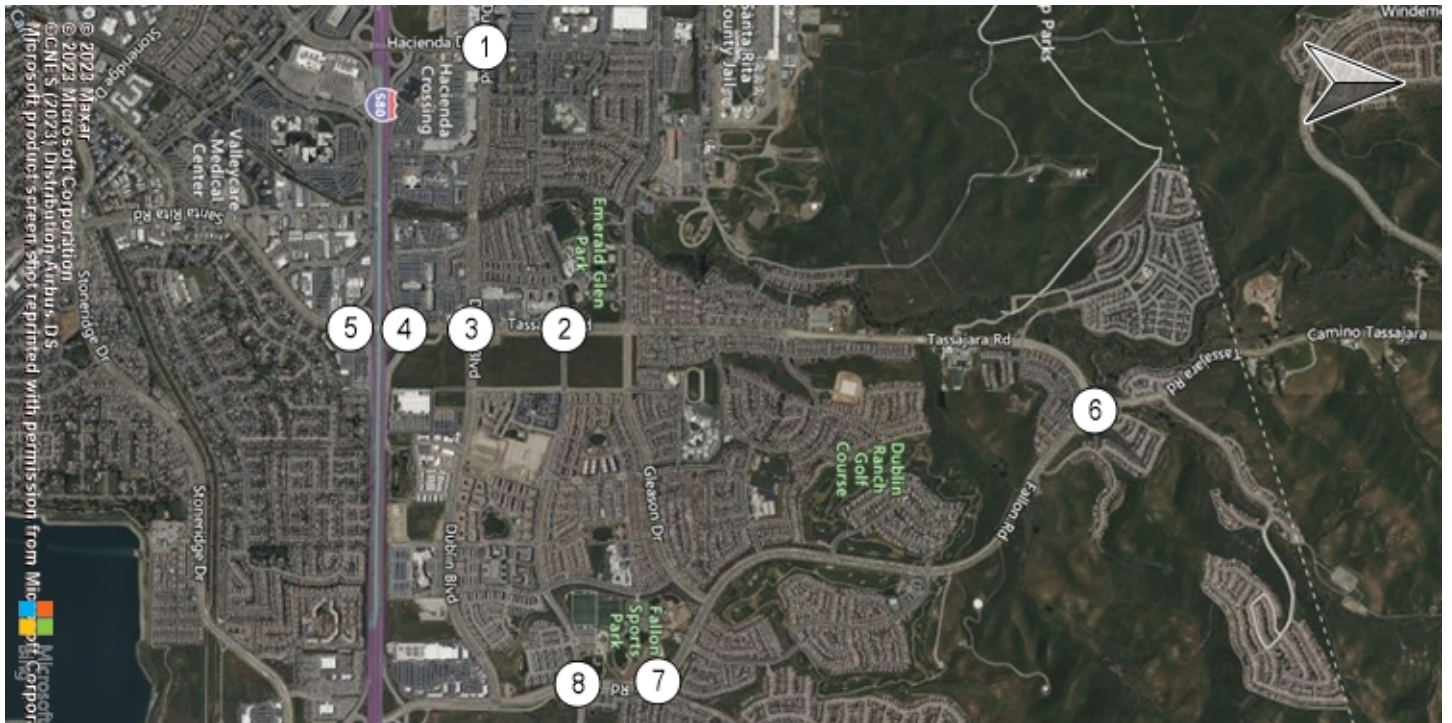

Hacienda Drive & Dublin Boul Tassajara Road & Central Pa Tassajara Road & Dublin Bou Tassajara Road & I-580 WB

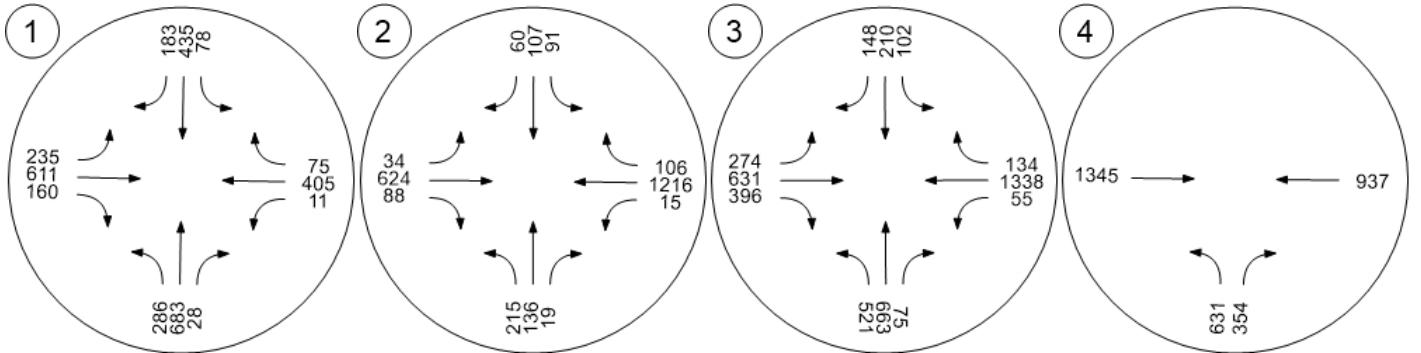

Santa Rita Rd & I-580 EB Ra Tassajara Road & Fallon Roa Fallon Road & Positano Park Fallon Road & Central Parkw

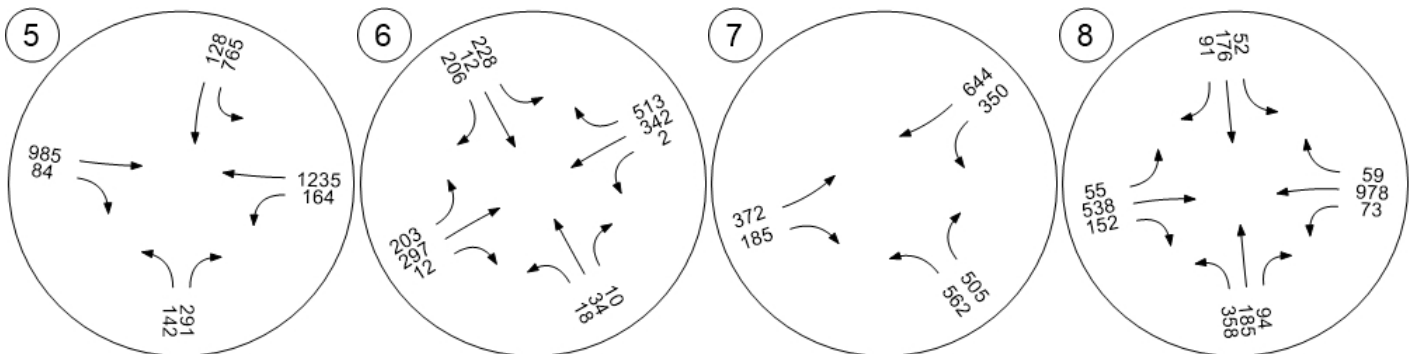



Traffic Volume - Base Volume

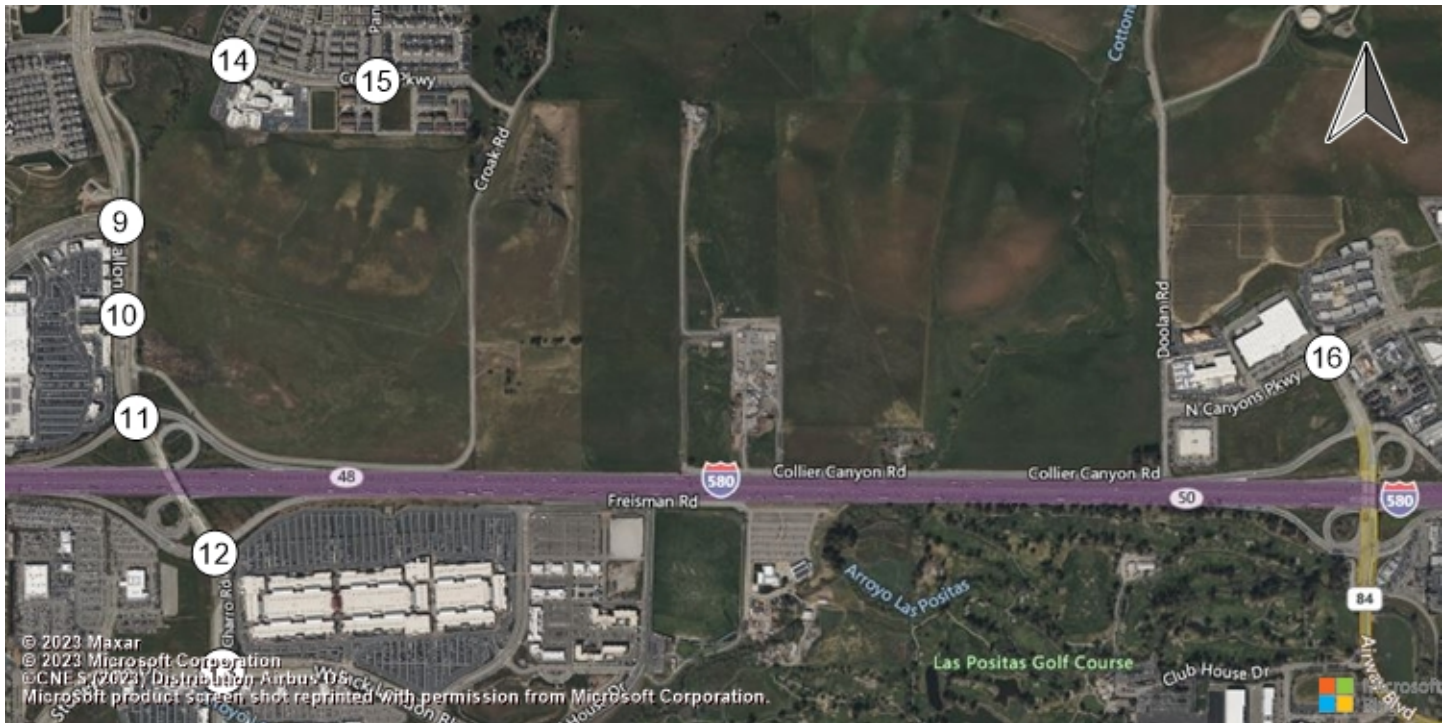

Fallon Road & Dublin Boulev Fallon Road & Fallon Gatewa Fallon Road & I-580 WB Ram El Charro Road & I-580 EB R

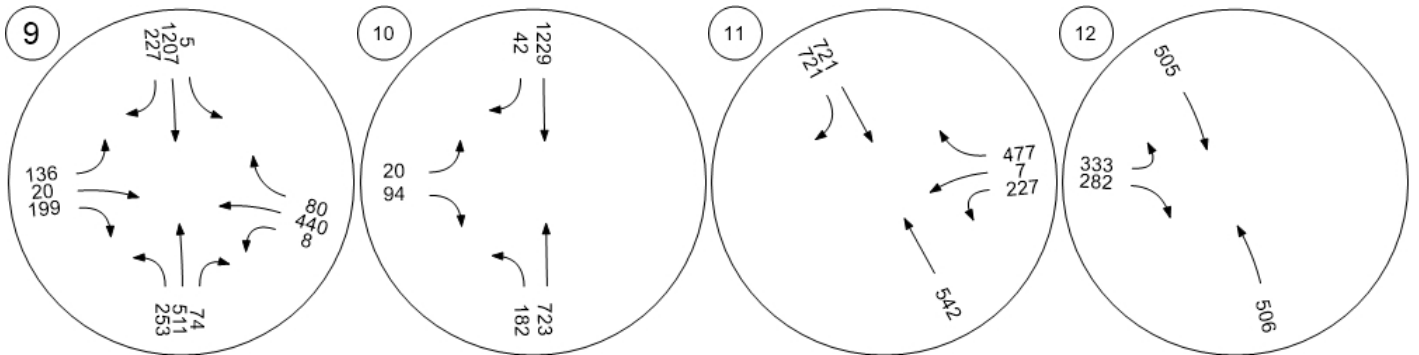

El Charro Road & Jack Lond Central Parkway & Sunset ViCentral Parkway & Panorama Airway Boulevard & N. Canyo

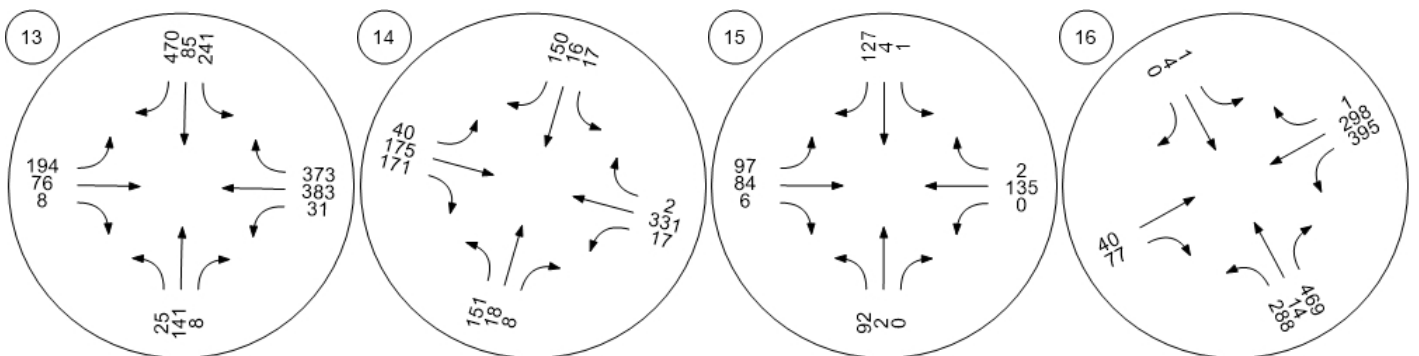

Traffic Volume - Base Volume

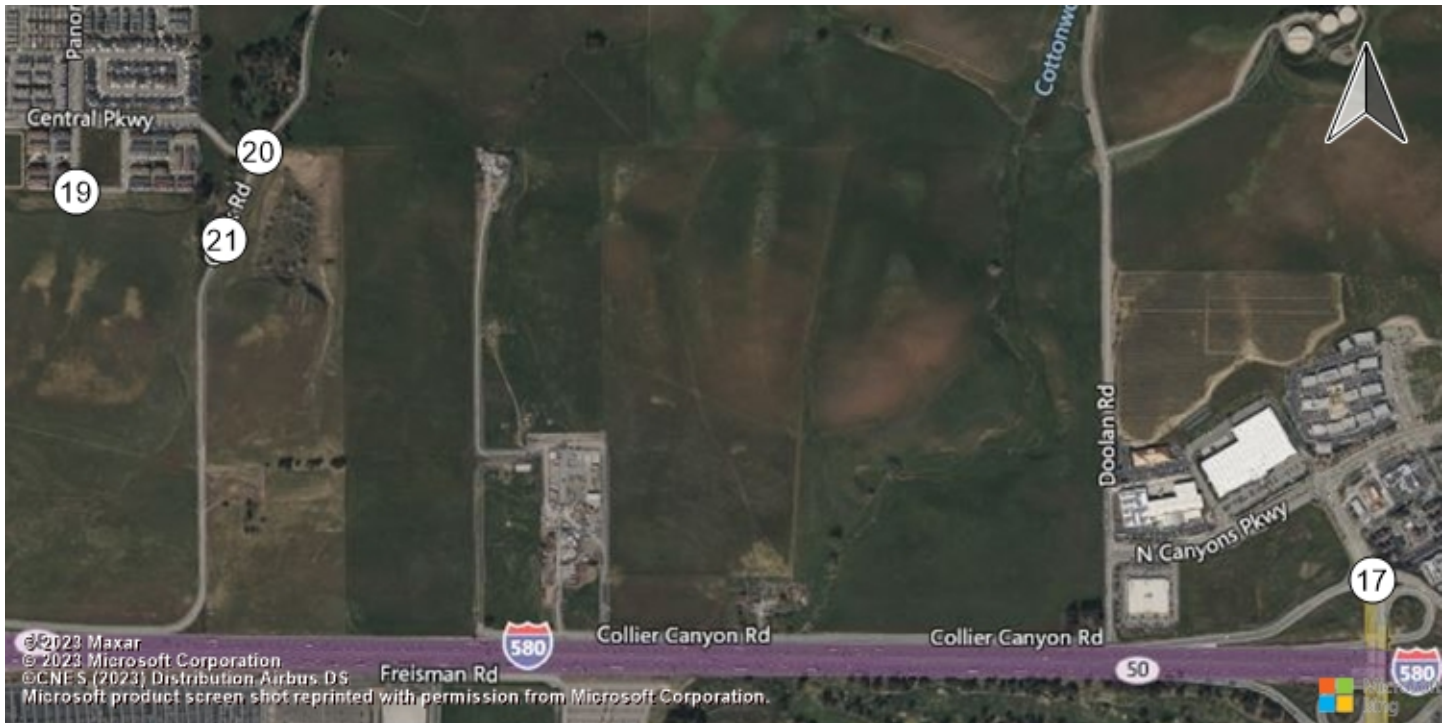

Airway Boulevard & I-580 WB Pandora Way & Residential P Croak Road & Central Parkw Croak Road & Project Access

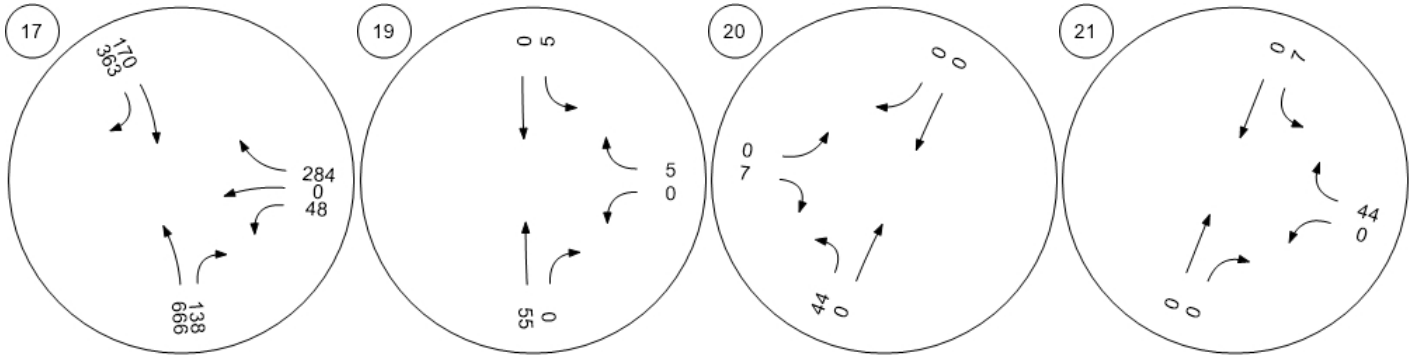



Traffic Volume - Base Volume

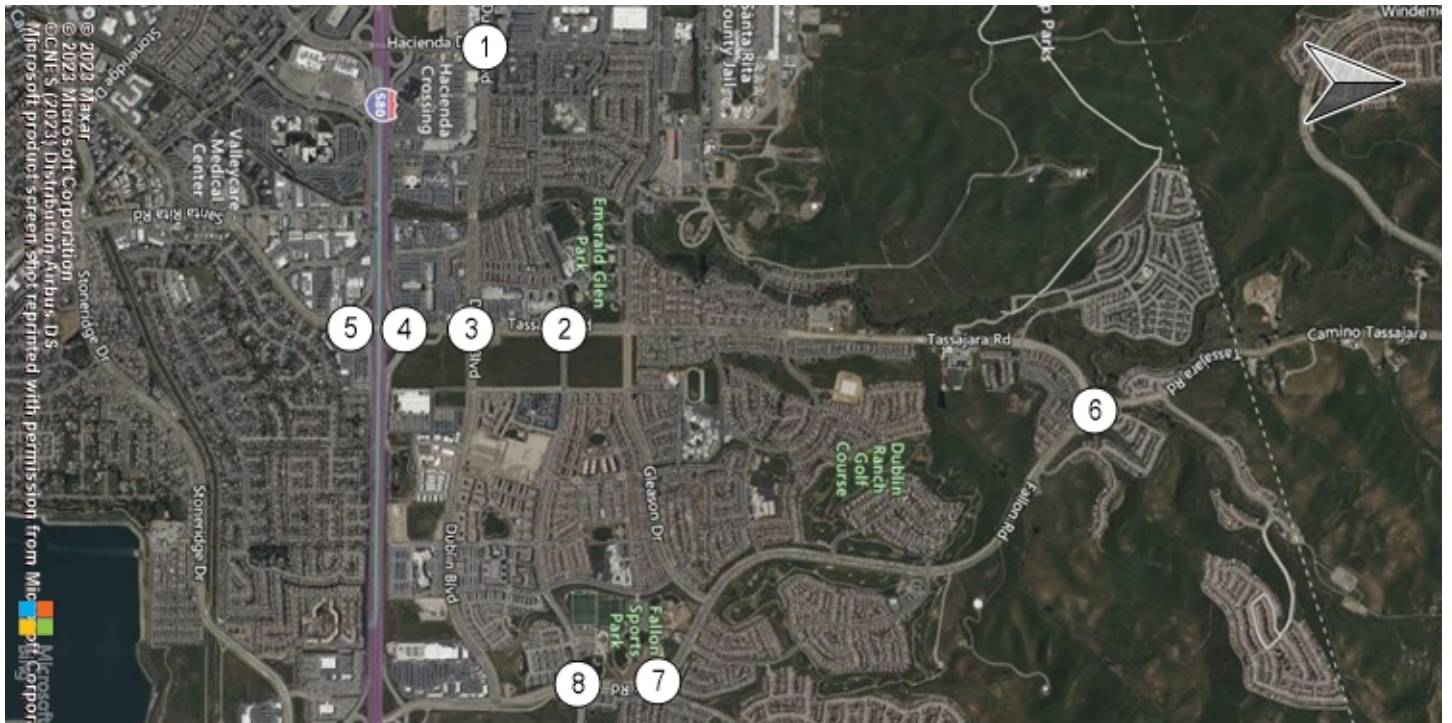

Hacienda Drive & Dublin Boul Tassajara Road & Central Pa Tassajara Road & Dublin Bou Tassajara Road & I-580 WB

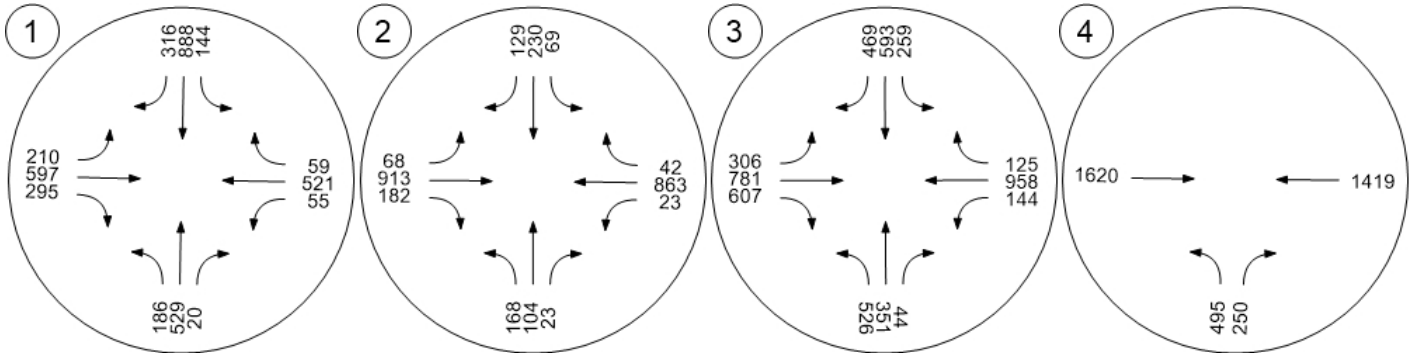

Santa Rita Rd & I-580 EB Ra Tassajara Road & Fallon Roa Fallon Road & Positano Park Fallon Road & Central Parkw

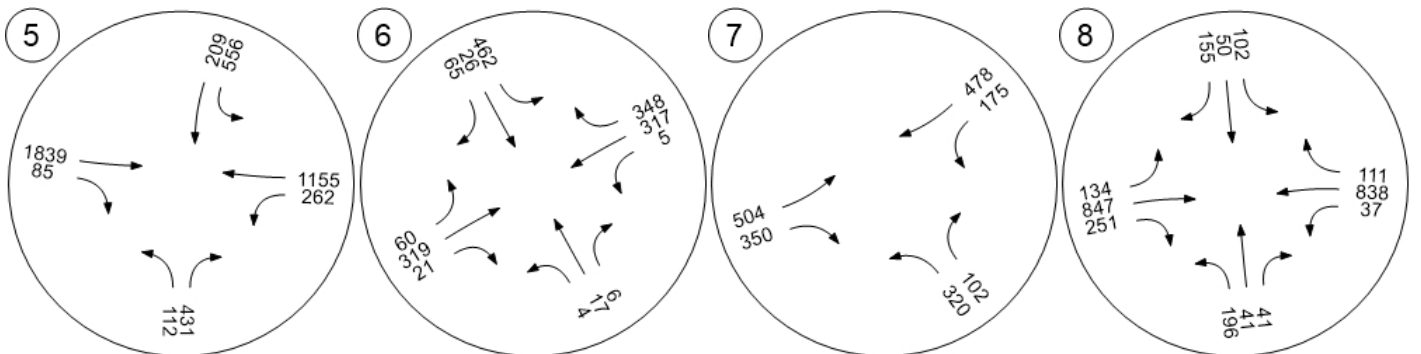



Traffic Volume - Base Volume

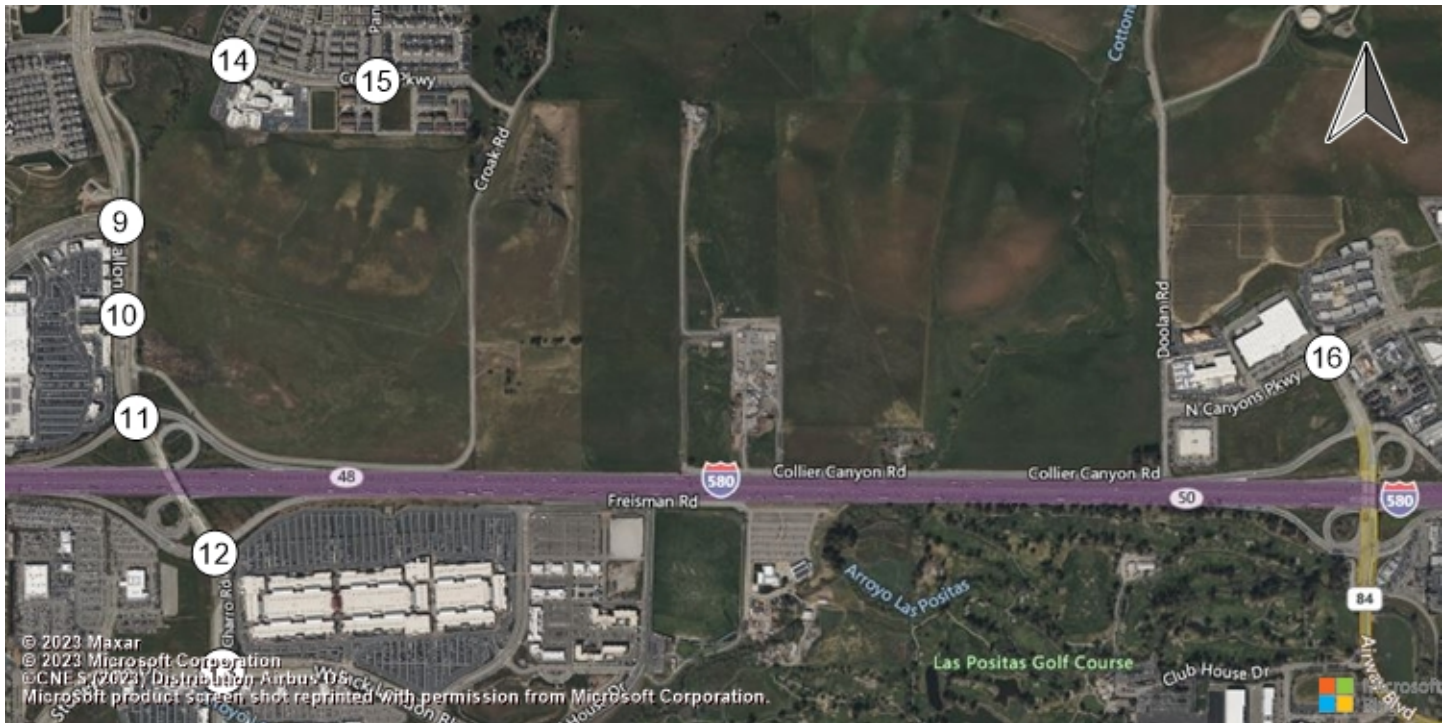

Fallon Road & Dublin Boulevard Fallon Road & Fallon Gateways Fallon Road & I-580 WB Ram El Charro Road & I-580 EB R

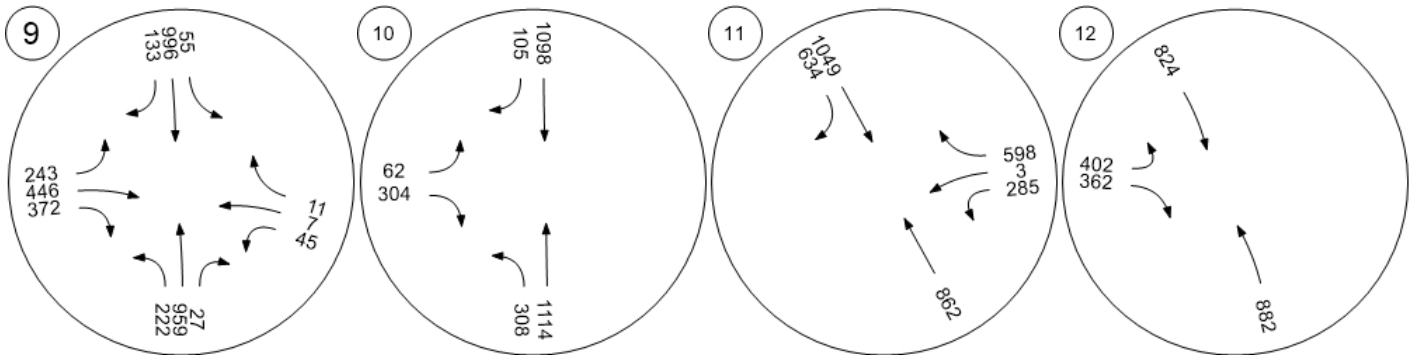

El Charro Road & Jack Lond Central Parkway & Sunset Vi Central Parkway & Panorama Airway Boulevard & N. Canyon

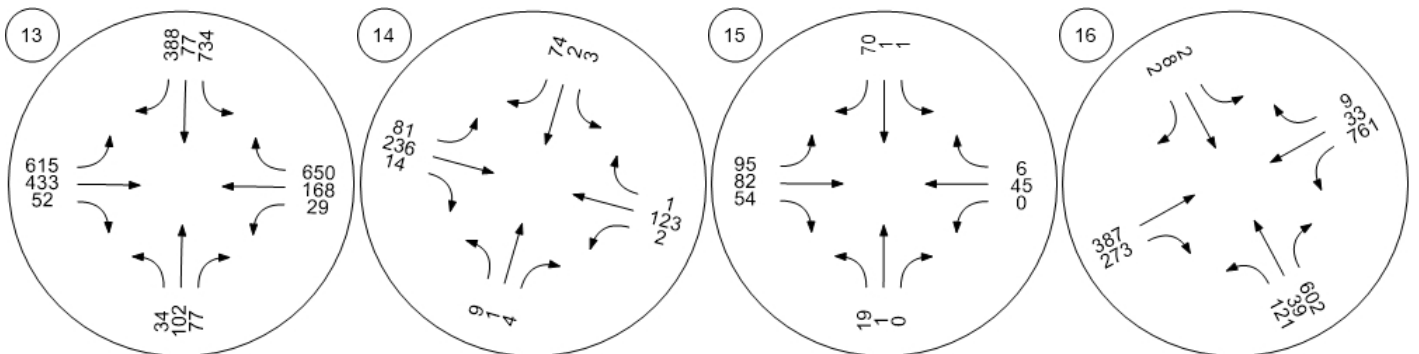

Traffic Volume - Base Volume

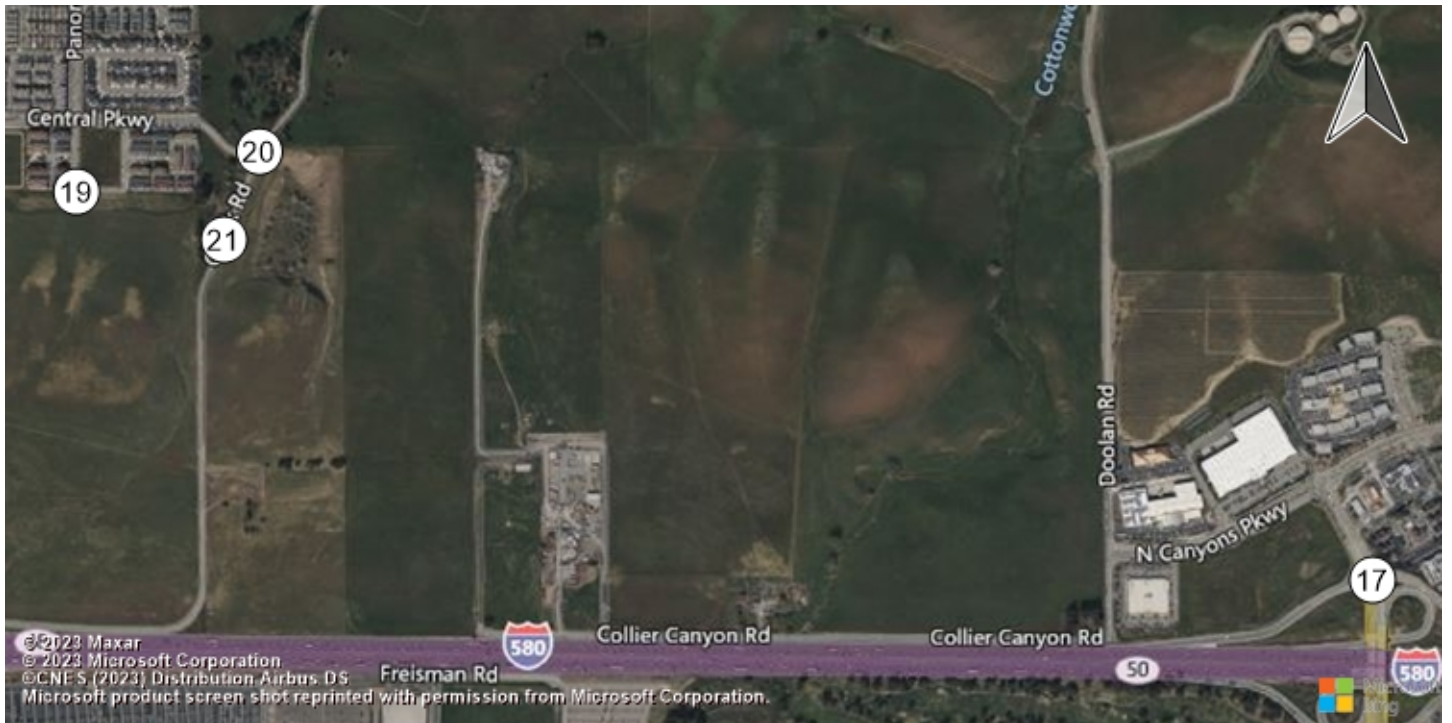

Airway Boulevard & I-580 WB Pandora Way & Residential P Croak Road & Central Parkw Croak Road & Project Access

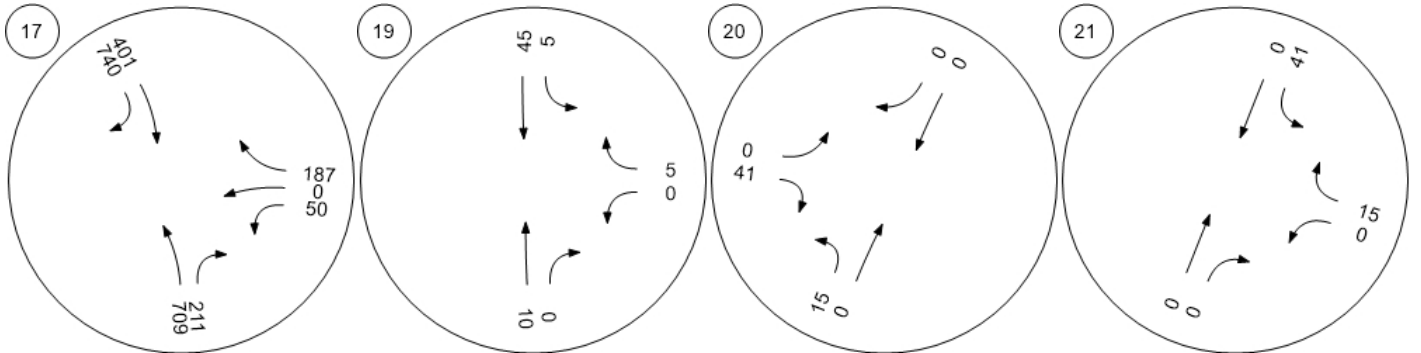



## Appendix G: Near-Term Plus Project Operational Outputs

Vistro File: H:\...\PacVest\_20240229.vistro

Scenario 5 Near Term Plus Project AM

Report File: H:\...\NearTermAM\_PP\_LOS.pdf

3/1/2024

**Intersection Analysis Summary**

ID	Intersection Name	Control Type	Method	Worst Mvmt	V/C	Delay (s/veh)	LOS
1	Hacienda Drive & Dublin Boulevard	Signalized	HCM 7th Edition	SB Left	0.390	41.9	D
2	Tassajara Road & Central Parkway	Signalized	HCM 7th Edition	SB Left	0.594	28.4	C
3	Tassajara Road & Dublin Boulevard	Signalized	HCM 7th Edition	WB Left	0.603	40.0	D
4	Tassajara Road & I-580 WB Ramps	Signalized	HCM 7th Edition	WB Left	0.631	13.4	B
5	Santa Rita Rd & I-580 EB Ramps/Pimlico Dr	Signalized	HCM 7th Edition	SB Left	0.753	32.5	C
6	Tassajara Road & Fallon Road	Signalized	HCM 7th Edition	SB Left	0.666	22.8	C
7	Fallon Road & Positano Parkway	Signalized	HCM 7th Edition	WB Right	0.859	31.7	C
8	Fallon Road & Central Parkway	Signalized	HCM 7th Edition	SB Left	0.605	34.1	C
9	Fallon Road & Dublin Boulevard	Signalized	HCM 7th Edition	WB Left	0.567	23.4	C
10	Fallon Road & Fallon Gateway	Signalized	HCM 7th Edition	NB Left	0.543	13.5	B
11	Fallon Road & I-580 WB Ramps	Signalized	HCM 7th Edition	WB Left	0.777	9.0	A
12	El Charro Road & I-580 EB Ramps	Signalized	HCM 7th Edition	EB Right	0.442	6.8	A
13	El Charro Road & Jack London Boulevard	Signalized	HCM 7th Edition	WB Left	0.416	13.8	B
14	Central Parkway & Sunset View Drive	Signalized	HCM 7th Edition	WB Thru	0.856	42.5	D
15	Central Parkway & Panorama Drive/Pino Grande Road	All-way stop	HCM 7th Edition	WB Thru	0.465	13.3	B
16	Airway Boulevard & N. Canyons Parkway	Signalized	HCM 7th Edition	SB Thru	0.436	17.9	B
17	Airway Boulevard & I-580 WB Ramps	Signalized	HCM 7th Edition	WB Left	0.254	13.4	B



19	Pandora Way & Residential Project Access Driveway (Parcel 7)	All-way stop	HCM 7th Edition	SB Left	0.060	7.1	A
20	Croak Road & Central Parkway	All-way stop	HCM 7th Edition	NB Left	0.062	7.9	A
21	Croak Road & Project Access (Parcel 8)	Two-way stop	HCM 7th Edition	WB Right	0.041	8.5	A

V/C, Delay, LOS: For two-way stop, these values are taken from the movement with the worst (highest) delay value. For all other control types, they are taken for the whole intersection.

**Intersection Level Of Service Report**  
**Intersection 1: Hacienda Drive & Dublin Boulevard**

Control Type:	Signalized	Delay (sec / veh):	41.9
Analysis Method:	HCM 7th Edition	Level Of Service:	D
Analysis Period:	15 minutes	Volume to Capacity (v/c):	0.390

**Intersection Setup**

Name	Hacienda Drive			Hacienda Drive			Dublin Boulevard			Dublin Boulevard		
Approach	Northbound			Southbound			Eastbound			Westbound		
Lane Configuration	[Diagram]			[Diagram]			[Diagram]			[Diagram]		
Turning Movement	Left	Thru	Right	Left	Thru	Right	Left	Thru	Right	Left	Thru	Right
Lane Width [ft]	12.00	12.00	12.00	12.00	12.00	12.00	12.00	12.00	12.00	12.00	12.00	12.00
No. of Lanes in Entry Pocket	2	0	2	2	0	1	2	0	2	2	0	0
Entry Pocket Length [ft]	250.00	100.00	380.00	300.00	100.00	220.00	300.00	100.00	250.00	275.00	100.00	100.00
No. of Lanes in Exit Pocket	0	0	0	0	0	0	0	0	0	0	0	1
Exit Pocket Length [ft]	0.00	0.00	0.00	0.00	0.00	0.00	0.00	0.00	0.00	0.00	0.00	1000.00
Speed [mph]	35.00			35.00			40.00			40.00		
Grade [%]	0.00			0.00			0.00			0.00		
Curb Present	Yes			Yes			Yes			Yes		
Crosswalk	Yes			Yes			Yes			Yes		





**Volumes**

Name	Hacienda Drive			Hacienda Drive			Dublin Boulevard			Dublin Boulevard		
Base Volume Input [veh/h]	235	611	160	11	405	75	78	435	183	286	683	28
Base Volume Adjustment Factor	1.0000	1.0000	1.0000	1.0000	1.0000	1.0000	1.0000	1.0000	1.0000	1.0000	1.0000	1.0000
Heavy Vehicles Percentage [%]	3.40	1.10	1.90	0.00	1.50	4.50	5.20	1.70	8.60	0.50	2.30	4.80
Proportion of CAVs [%]	0.00											
Growth Factor	1.0000	1.0000	1.0000	1.0000	1.0000	1.0000	1.0000	1.0000	1.0000	1.0000	1.0000	1.0000
In-Process Volume [veh/h]	0	0	0	0	0	0	0	0	0	0	0	0
Site-Generated Trips [veh/h]	0	0	0	0	0	0	0	0	0	0	0	0
Diverted Trips [veh/h]	0	0	0	0	0	0	0	0	0	0	0	0
Pass-by Trips [veh/h]	0	0	0	0	0	0	0	0	0	0	0	0
Existing Site Adjustment Volume [veh/h]	0	0	0	0	0	0	0	0	0	0	0	0
Other Volume [veh/h]	0	0	0	0	0	0	0	0	0	0	0	0
Right Turn on Red Volume [veh/h]	0	0	0	0	0	0	0	0	0	0	0	0
Total Hourly Volume [veh/h]	235	611	160	11	405	75	78	435	183	286	683	28
Peak Hour Factor	0.9500	0.9500	0.9500	0.9500	0.9500	0.9500	0.9500	0.9500	0.9500	0.9500	0.9500	0.9500
Other Adjustment Factor	1.0000	1.0000	1.0000	1.0000	1.0000	1.0000	1.0000	1.0000	1.0000	1.0000	1.0000	1.0000
Total 15-Minute Volume [veh/h]	62	161	42	3	107	20	21	114	48	75	180	7
Total Analysis Volume [veh/h]	247	643	168	12	426	79	82	458	193	301	719	29
Presence of On-Street Parking	No		No	No		No	No		No	No		No
On-Street Parking Maneuver Rate [/h]	0	0	0	0	0	0	0	0	0	0	0	0
Local Bus Stopping Rate [/h]	0	0	0	0	0	0	0	0	0	0	0	0
v_do, Outbound Pedestrian Volume crossing	1			3			0			2		
v_di, Inbound Pedestrian Volume crossing m	0			2			1			3		
v_co, Outbound Pedestrian Volume crossing	0			2			3			1		
v_ci, Inbound Pedestrian Volume crossing mi	1			3			2			0		
v_ab, Corner Pedestrian Volume [ped/h]	0			0			0			0		
Bicycle Volume [bicycles/h]	0			0			0			1		



**Intersection Settings**

Located in CBD	No
Signal Coordination Group	-
Cycle Length [s]	150
Active Pattern	Pattern 1
Coordination Type	Time of Day Pattern Coordinated
Actuation Type	Fully actuated
Offset [s]	57.0
Offset Reference	Lead Green - Beginning of First Green
Permissive Mode	SingleBand
Lost time [s]	12.00

**Phasing & Timing (Basic)**

Control Type	Protecte	Permiss	Permiss	Protecte	Permiss	Permiss	Protecte	Permiss	Permiss	Protecte	Permiss	Permiss
Signal Group	3	8	0	7	4	0	5	2	0	1	6	0
Auxiliary Signal Groups												
Maximum Green [s]	20	50	0	20	50	0	20	60	0	20	60	0
Amber [s]	3.5	4.5	0.0	3.5	4.1	0.0	3.5	4.5	0.0	3.5	4.5	0.0
All red [s]	1.5	1.5	0.0	1.0	1.5	0.0	1.0	1.5	0.0	1.0	1.5	0.0
Walk [s]	0	4	0	0	4	0	0	4	0	0	4	0
Pedestrian Clearance [s]	0	32	0	0	40	0	0	43	0	0	35	0
Delayed Vehicle Green [s]	0.0	0.0	0.0	0.0	0.0	0.0	0.0	0.0	0.0	0.0	0.0	0.0
Rest In Walk		No			No			No			No	
I1, Start-Up Lost Time [s]	2.0	2.0	0.0	2.0	2.0	0.0	2.0	2.0	0.0	2.0	2.0	0.0
I2, Clearance Lost Time [s]	2.0	2.0	0.0	2.0	2.0	0.0	2.0	2.0	0.0	2.0	2.0	0.0
Detector Location [ft]	0.0	0.0	0.0	0.0	0.0	0.0	0.0	0.0	0.0	0.0	0.0	0.0
Detector Length [ft]	20.0	20.0	0.0	20.0	20.0	0.0	20.0	20.0	0.0	20.0	20.0	0.0
I, Upstream Filtering Factor	1.00	1.00	1.00	1.00	1.00	1.00	1.00	1.00	1.00	1.00	1.00	1.00

**Phasing & Timing: Pattern 1**

Split [s]	18	55	0	14	51	0	15	61	0	20	66	0
Lead / Lag	Lead	-	-	Lead	-	-	Lead	-	-	Lead	-	-
Minimum Green [s]	4	10	0	4	10	0	4	10	0	8	10	0
Vehicle Extension [s]	3.0	3.5	0.0	3.0	3.5	0.0	3.0	3.5	0.0	3.0	3.5	0.0
Minimum Recall	No	No		No	No		No	Yes		No	Yes	
Maximum Recall	No	No		No	No		No	No		No	No	
Pedestrian Recall	No	No		No	No		No	No		No	No	

**Exclusive Pedestrian Phase**

Pedestrian Signal Group	0
Pedestrian Walk [s]	0
Pedestrian Clearance [s]	0





**Lane Group Calculations**

Lane Group	L	C	R	L	C	R	L	C	R	L	C	C
C, Cycle Length [s]	150	150	150	150	150	150	150	150	150	150	150	150
L, Total Lost Time per Cycle [s]	4.00	4.00	4.00	4.00	4.00	4.00	4.00	4.00	4.00	4.00	4.00	4.00
l1_p, Permitted Start-Up Lost Time [s]	0.00	0.00	0.00	0.00	0.00	0.00	0.00	0.00	0.00	0.00	0.00	0.00
l2, Clearance Lost Time [s]	2.00	2.00	2.00	2.00	2.00	2.00	2.00	2.00	2.00	2.00	2.00	2.00
g_i, Effective Green Time [s]	10	33	33	2	25	25	6	83	83	15	93	93
g / C, Green / Cycle	0.07	0.22	0.22	0.01	0.17	0.17	0.04	0.56	0.56	0.10	0.62	0.62
(v / s)_i Volume / Saturation Flow Rate	0.05	0.18	0.06	0.00	0.08	0.05	0.02	0.09	0.07	0.09	0.14	0.14
s, saturation flow rate [veh/h]	5130	3586	2812	3514	5114	1544	3370	5106	2663	3500	3552	1825
c, Capacity [veh/h]	356	795	624	50	852	257	136	2835	1478	357	2192	1126
d1, Uniform Delay [s]	68.26	55.37	48.33	73.16	56.85	54.90	70.85	16.31	16.01	66.20	12.78	12.79
k, delay calibration	0.11	0.13	0.13	0.11	0.13	0.13	0.11	0.50	0.50	0.11	0.50	0.50
l, Upstream Filtering Factor	1.00	1.00	1.00	1.00	1.00	1.00	1.00	1.00	1.00	1.00	1.00	1.00
d2, Incremental Delay [s]	2.42	2.42	0.28	2.40	0.55	0.81	4.29	0.12	0.18	5.41	0.24	0.47
d3, Initial Queue Delay [s]	0.00	0.00	0.00	0.00	0.00	0.00	0.00	0.00	0.00	0.00	0.00	0.00
Rp, platoon ratio	1.00	1.00	1.00	1.00	1.00	1.00	1.00	1.00	1.00	1.00	1.00	1.00
PF, progression factor	1.00	1.00	1.00	1.00	1.00	1.00	1.00	1.00	1.00	1.00	1.00	1.00

**Lane Group Results**

X, volume / capacity	0.69	0.81	0.27	0.24	0.50	0.31	0.60	0.16	0.13	0.84	0.23	0.23
d, Delay for Lane Group [s/veh]	70.68	57.79	48.61	75.56	57.40	55.71	75.13	16.43	16.19	71.61	13.02	13.26
Lane Group LOS	E	E	D	E	E	E	E	B	B	E	B	B
Critical Lane Group	No	Yes	No	Yes	No	No	No	Yes	No	Yes	No	No
50th-Percentile Queue Length [veh/ln]	3.17	11.76	2.64	0.25	4.94	2.69	1.62	2.58	1.62	5.88	3.68	3.87
50th-Percentile Queue Length [ft/ln]	79.15	293.94	66.10	6.14	123.59	67.26	40.54	64.45	40.42	147.05	92.08	96.79
95th-Percentile Queue Length [veh/ln]	5.70	17.38	4.76	0.44	8.59	4.84	2.92	4.64	2.91	9.86	6.63	6.97
95th-Percentile Queue Length [ft/ln]	142.47	434.52	118.99	11.05	214.75	121.06	72.98	116.00	72.75	246.48	165.74	174.22



**Movement, Approach, & Intersection Results**

d_M, Delay for Movement [s/veh]	70.68	57.79	48.61	75.56	57.40	55.71	75.13	16.43	16.19	71.61	13.09	13.26
Movement LOS	E	E	D	E	E	E	E	B	B	E	B	B
d_A, Approach Delay [s/veh]	59.34			57.56			22.94			29.89		
Approach LOS	E			E			C			C		
d_I, Intersection Delay [s/veh]	41.92											
Intersection LOS	D											
Intersection V/C	0.390											

**Emissions**

Vehicle Miles Traveled [mph]	25.07	65.25	17.05	1.40	49.58	9.20	9.37	52.35	22.06	264.67	433.96	223.77
Stops [stops/h]	227.88	564.21	126.88	11.78	355.83	64.55	77.82	185.55	77.58	282.25	176.75	92.89
Fuel consumption [US gal/h]	6.22	14.29	3.27	0.33	9.54	1.73	2.35	5.23	2.19	16.64	18.59	9.61
CO [g/h]	434.88	999.01	228.27	22.81	666.95	121.02	164.53	365.54	152.95	1163.06	1299.34	672.07
NOx [g/h]	84.61	194.37	44.41	4.44	129.76	23.55	32.01	71.12	29.76	226.29	252.80	130.76
VOC [g/h]	100.79	231.53	52.90	5.29	154.57	28.05	38.13	84.72	35.45	269.55	301.13	155.76

**Other Modes**

g_Walk,mi, Effective Walk Time [s]	8.0			8.0			8.0			8.0		
M_corner, Corner Circulation Area [ft <sup>2</sup> /ped]	0.00			0.00			0.00			0.00		
M_CW, Crosswalk Circulation Area [ft <sup>2</sup> /ped]	3359.36			918.66			857.57			3179.53		
d_p, Pedestrian Delay [s]	67.23			67.23			67.23			67.23		
I_p,int, Pedestrian LOS Score for Intersectio	3.218			2.932			3.224			3.026		
Crosswalk LOS	C			C			C			C		
s_b, Saturation Flow Rate of the bicycle lane	2000			2000			2000			2000		
c_b, Capacity of the bicycle lane [bicycles/h]	653			605			733			800		
d_b, Bicycle Delay [s]	34.02			36.49			30.10			27.03		
I_b,int, Bicycle LOS Score for Intersection	2.432			1.844			1.963			2.137		
Bicycle LOS	B			A			A			B		

**Sequence**

Ring 1	1	2	3	4	-	-	-	-	-	-	-	-	-	-	-
Ring 2	5	6	7	8	-	-	-	-	-	-	-	-	-	-	-
Ring 3	-	-	-	-	-	-	-	-	-	-	-	-	-	-	-
Ring 4	-	-	-	-	-	-	-	-	-	-	-	-	-	-	-

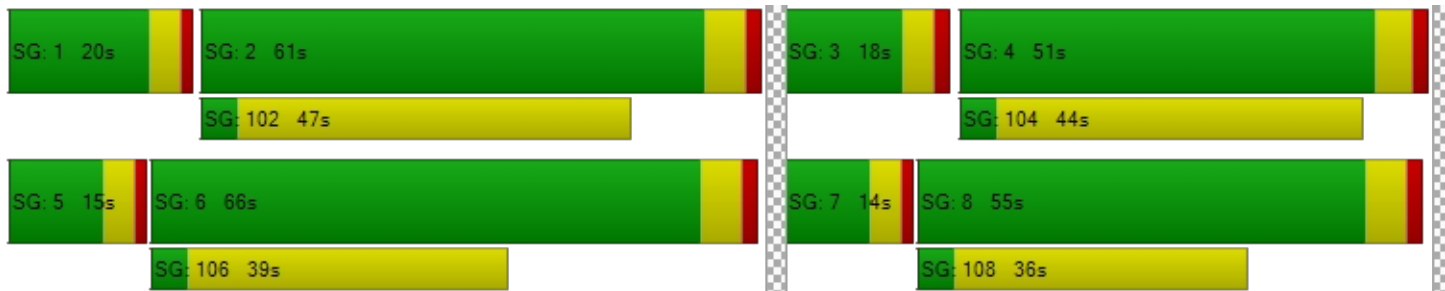

**Intersection Level Of Service Report**  
**Intersection 2: Tassajara Road & Central Parkway**

Control Type:	Signalized	Delay (sec / veh):	28.4
Analysis Method:	HCM 7th Edition	Level Of Service:	C
Analysis Period:	15 minutes	Volume to Capacity (v/c):	0.594

**Intersection Setup**

Name	Tassajara Road			Tassajara Road			Central Parkway			Central Parkway		
Approach	Northbound			Southbound			Eastbound			Westbound		
Lane Configuration	⇐   ⇐			⇐   ⇐			⇐  ⇐			⇐  ⇐		
Turning Movement	Left	Thru	Right	Left	Thru	Right	Left	Thru	Right	Left	Thru	Right
Lane Width [ft]	12.00	12.00	12.00	12.00	12.00	12.00	12.00	12.00	12.00	12.00	12.00	12.00
No. of Lanes in Entry Pocket	1	0	1	1	0	1	1	0	1	2	0	0
Entry Pocket Length [ft]	325.00	100.00	325.00	300.00	100.00	215.00	225.00	100.00	225.00	300.00	100.00	100.00
No. of Lanes in Exit Pocket	0	0	0	0	0	0	0	0	0	0	0	0
Exit Pocket Length [ft]	0.00	0.00	0.00	0.00	0.00	0.00	0.00	0.00	0.00	0.00	0.00	0.00
Speed [mph]	40.00			40.00			35.00			35.00		
Grade [%]	0.00			0.00			0.00			0.00		
Curb Present	Yes			Yes			Yes			Yes		
Crosswalk	Yes			Yes			Yes			Yes		



**Volumes**

Name	Tassajara Road			Tassajara Road			Central Parkway			Central Parkway		
Base Volume Input [veh/h]	34	624	88	15	1216	106	91	107	60	215	136	19
Base Volume Adjustment Factor	1.0000	1.0000	1.0000	1.0000	1.0000	1.0000	1.0000	1.0000	1.0000	1.0000	1.0000	1.0000
Heavy Vehicles Percentage [%]	0.00	2.00	8.50	0.00	0.70	2.10	1.10	0.00	1.70	0.90	0.00	0.00
Proportion of CAVs [%]	0.00											
Growth Factor	1.0000	1.0000	1.0000	1.0000	1.0000	1.0000	1.0000	1.0000	1.0000	1.0000	1.0000	1.0000
In-Process Volume [veh/h]	0	0	0	0	0	0	0	0	0	0	0	0
Site-Generated Trips [veh/h]	0	0	0	0	0	0	0	0	0	0	0	0
Diverted Trips [veh/h]	0	0	0	0	0	0	0	0	0	0	0	0
Pass-by Trips [veh/h]	0	0	0	0	0	0	0	0	0	0	0	0
Existing Site Adjustment Volume [veh/h]	0	0	0	0	0	0	0	0	0	0	0	0
Other Volume [veh/h]	0	0	0	0	0	0	0	0	0	0	0	0
Right Turn on Red Volume [veh/h]	0	0	0	0	0	0	0	0	0	0	0	0
Total Hourly Volume [veh/h]	34	624	88	15	1216	106	91	107	60	215	136	19
Peak Hour Factor	0.9100	0.9100	0.9100	0.9100	0.9100	0.9100	0.9100	0.9100	0.9100	0.9100	0.9100	0.9100
Other Adjustment Factor	1.0000	1.0000	1.0000	1.0000	1.0000	1.0000	1.0000	1.0000	1.0000	1.0000	1.0000	1.0000
Total 15-Minute Volume [veh/h]	9	171	24	4	334	29	25	29	16	59	37	5
Total Analysis Volume [veh/h]	37	686	97	16	1336	116	100	118	66	236	149	21
Presence of On-Street Parking	No		No	No		No	No		No	No		No
On-Street Parking Maneuver Rate [/h]	0	0	0	0	0	0	0	0	0	0	0	0
Local Bus Stopping Rate [/h]	0	0	0	0	0	0	0	0	0	0	0	0
v_do, Outbound Pedestrian Volume crossing	2			2			1			2		
v_di, Inbound Pedestrian Volume crossing m	1			2			2			2		
v_co, Outbound Pedestrian Volume crossing	1			6			7			2		
v_ci, Inbound Pedestrian Volume crossing mi	2			7			6			1		
v_ab, Corner Pedestrian Volume [ped/h]	0			0			0			0		
Bicycle Volume [bicycles/h]	0			0			0			12		



**Intersection Settings**

Located in CBD	No
Signal Coordination Group	-
Cycle Length [s]	130
Active Pattern	Pattern 1
Coordination Type	Time of Day Pattern Coordinated
Actuation Type	Fully actuated
Offset [s]	20.0
Offset Reference	Lead Green - Beginning of First Green
Permissive Mode	SingleBand
Lost time [s]	12.00

**Phasing & Timing (Basic)**

Control Type	Protecte	Permiss	Permiss	Protecte	Permiss	Permiss	Protecte	Permiss	Permiss	Protecte	Permiss	Permiss
Signal Group	3	8	0	7	4	0	5	2	0	1	6	0
Auxiliary Signal Groups												
Maximum Green [s]	20	40	0	20	40	0	20	20	0	20	20	0
Amber [s]	3.5	4.3	0.0	3.5	4.3	0.0	3.5	4.1	0.0	3.5	4.1	0.0
All red [s]	1.0	1.0	0.0	1.0	1.0	0.0	1.0	1.0	0.0	1.0	1.0	0.0
Walk [s]	0	4	0	0	4	0	0	4	0	0	4	0
Pedestrian Clearance [s]	0	20	0	0	24	0	0	36	0	0	30	0
Delayed Vehicle Green [s]	0.0	0.0	0.0	0.0	0.0	0.0	0.0	0.0	0.0	0.0	0.0	0.0
Rest In Walk		No			No			No			No	
I1, Start-Up Lost Time [s]	2.0	2.0	0.0	2.0	2.0	0.0	2.0	2.0	0.0	2.0	2.0	0.0
I2, Clearance Lost Time [s]	2.5	3.3	0.0	2.5	3.3	0.0	2.5	3.1	0.0	2.5	3.1	0.0
Detector Location [ft]	0.0	0.0	0.0	0.0	0.0	0.0	0.0	0.0	0.0	0.0	0.0	0.0
Detector Length [ft]	20.0	20.0	0.0	20.0	20.0	0.0	20.0	20.0	0.0	20.0	20.0	0.0
I, Upstream Filtering Factor	1.00	1.00	1.00	1.00	1.00	1.00	1.00	1.00	1.00	1.00	1.00	1.00

**Phasing & Timing: Pattern 1**

Split [s]	18	48	0	18	48	0	23	45	0	19	41	0
Lead / Lag	Lead	-	-	Lead	-	-	Lead	-	-	Lead	-	-
Minimum Green [s]	13	12	0	13	12	0	13	13	0	14	13	0
Vehicle Extension [s]	2.5	4.0	0.0	2.5	4.0	0.0	2.5	2.5	0.0	2.5	2.5	0.0
Minimum Recall	No	Yes		No	Yes		No	No		No	No	
Maximum Recall	No	No		No	No		No	No		No	No	
Pedestrian Recall	No	No		No	No		No	No		No	No	

**Exclusive Pedestrian Phase**

Pedestrian Signal Group	0
Pedestrian Walk [s]	0
Pedestrian Clearance [s]	0



**Lane Group Calculations**

Lane Group	L	C	R	L	C	R	L	C	R	L	C
C, Cycle Length [s]	130	130	130	130	130	130	130	130	130	130	130
L, Total Lost Time per Cycle [s]	4.50	5.30	5.30	4.50	5.30	5.30	4.50	5.10	5.10	4.50	5.10
l1_p, Permitted Start-Up Lost Time [s]	0.00	0.00	0.00	0.00	0.00	0.00	0.00	0.00	0.00	0.00	0.00
l2, Clearance Lost Time [s]	2.50	3.30	3.30	2.50	3.30	3.30	2.50	3.10	3.10	2.50	3.10
g_i, Effective Green Time [s]	10	76	76	6	73	73	13	14	14	14	16
g / C, Green / Cycle	0.07	0.59	0.59	0.04	0.56	0.56	0.10	0.11	0.11	0.11	0.12
(v / s)_i Volume / Saturation Flow Rate	0.02	0.19	0.06	0.01	0.37	0.07	0.06	0.06	0.04	0.07	0.09
s, saturation flow rate [veh/h]	1810	3560	1503	1810	3598	1570	1794	1900	1580	3489	1848
c, Capacity [veh/h]	134	2091	883	80	2006	875	175	211	176	376	225
d1, Uniform Delay [s]	56.88	13.70	11.83	59.88	20.23	13.72	56.05	54.73	53.55	55.47	55.22
k, delay calibration	0.08	0.50	0.50	0.08	0.50	0.50	0.08	0.08	0.08	0.08	0.08
l, Upstream Filtering Factor	1.00	1.00	1.00	1.00	1.00	1.00	1.00	1.00	1.00	1.00	1.00
d2, Incremental Delay [s]	0.82	0.42	0.25	0.90	1.77	0.31	2.18	1.71	0.98	1.28	3.86
d3, Initial Queue Delay [s]	0.00	0.00	0.00	0.00	0.00	0.00	0.00	0.00	0.00	0.00	0.00
Rp, platoon ratio	1.00	1.00	1.00	1.00	1.00	1.00	1.00	1.00	1.00	1.00	1.00
PF, progression factor	1.00	1.00	1.00	1.00	1.00	1.00	1.00	1.00	1.00	1.00	1.00

**Lane Group Results**

X, volume / capacity	0.28	0.33	0.11	0.20	0.67	0.13	0.57	0.56	0.38	0.63	0.76
d, Delay for Lane Group [s/veh]	57.71	14.12	12.08	60.78	21.99	14.03	58.22	56.44	54.53	56.75	59.08
Lane Group LOS	E	B	B	E	C	B	E	E	D	E	E
Critical Lane Group	Yes	No	No	No	Yes	No	Yes	No	No	No	Yes
50th-Percentile Queue Length [veh/ln]	1.17	5.03	1.26	0.52	13.90	1.66	3.23	3.75	2.04	3.75	5.60
50th-Percentile Queue Length [ft/ln]	29.19	125.68	31.47	13.08	347.59	41.39	80.69	93.67	51.09	93.75	139.93
95th-Percentile Queue Length [veh/ln]	2.10	8.70	2.27	0.94	20.02	2.98	5.81	6.74	3.68	6.75	9.48
95th-Percentile Queue Length [ft/ln]	52.54	217.61	56.64	23.55	500.46	74.51	145.24	168.61	91.96	168.76	236.93



**Movement, Approach, & Intersection Results**

d_M, Delay for Movement [s/veh]	57.71	14.12	12.08	60.78	21.99	14.03	58.22	56.44	54.53	56.75	59.08	59.08
Movement LOS	E	B	B	E	C	B	E	E	D	E	E	E
d_A, Approach Delay [s/veh]	15.85			21.79			56.62			57.72		
Approach LOS	B			C			E			E		
d_I, Intersection Delay [s/veh]	28.37											
Intersection LOS	C											
Intersection V/C	0.594											

**Emissions**

Vehicle Miles Traveled [mph]	10.67	197.83	27.97	3.04	254.14	22.07	13.16	15.53	8.69	32.00	23.05
Stops [stops/h]	32.34	278.47	34.86	14.49	770.16	45.86	89.39	103.78	56.60	207.73	155.02
Fuel consumption [US gal/h]	1.13	11.79	1.58	0.45	22.65	1.57	2.36	2.73	1.49	5.51	4.09
CO [g/h]	79.29	824.39	110.64	31.40	1583.15	109.89	164.87	190.65	104.08	384.94	285.77
NOx [g/h]	15.43	160.40	21.53	6.11	308.02	21.38	32.08	37.09	20.25	74.90	55.60
VOC [g/h]	18.38	191.06	25.64	7.28	366.91	25.47	38.21	44.19	24.12	89.21	66.23

**Other Modes**

g_Walk,mi, Effective Walk Time [s]	8.0			8.0			8.0			8.0		
M_corner, Corner Circulation Area [ft <sup>2</sup> /ped]	0.00			0.00			0.00			0.00		
M_CW, Crosswalk Circulation Area [ft <sup>2</sup> /ped]	1666.25			1344.85			261.03			1156.41		
d_p, Pedestrian Delay [s]	57.24			57.24			57.24			57.24		
I_p,int, Pedestrian LOS Score for Intersectio	3.144			2.965			2.317			2.332		
Crosswalk LOS	C			C			B			B		
s_b, Saturation Flow Rate of the bicycle lane	2000			2000			2000			2000		
c_b, Capacity of the bicycle lane [bicycles/h]	657			657			614			552		
d_b, Bicycle Delay [s]	29.30			29.30			31.21			34.25		
I_b,int, Bicycle LOS Score for Intersection	2.236			2.771			2.028			2.230		
Bicycle LOS	B			C			B			B		

**Sequence**

Ring 1	1	2	3	4	-	-	-	-	-	-	-	-	-	-	-
Ring 2	5	6	7	8	-	-	-	-	-	-	-	-	-	-	-
Ring 3	-	-	-	-	-	-	-	-	-	-	-	-	-	-	-
Ring 4	-	-	-	-	-	-	-	-	-	-	-	-	-	-	-

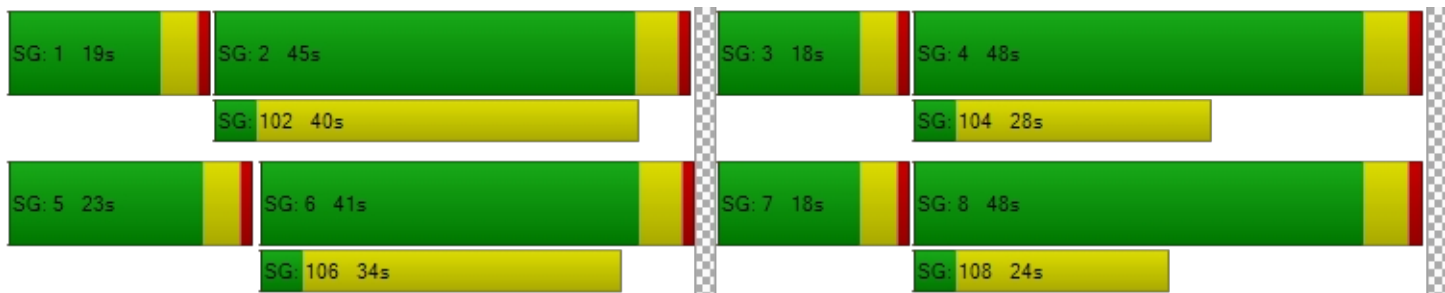

**Intersection Level Of Service Report**  
**Intersection 3: Tassajara Road & Dublin Boulevard**

Control Type:	Signalized	Delay (sec / veh):	40.0
Analysis Method:	HCM 7th Edition	Level Of Service:	D
Analysis Period:	15 minutes	Volume to Capacity (v/c):	0.603

**Intersection Setup**

Name	Tassajara Road			Tassajara Road			Dublin Boulevard			Dublin Boulevard		
Approach	Northbound			Southbound			Eastbound			Westbound		
Lane Configuration	[Diagram]			[Diagram]			[Diagram]			[Diagram]		
Turning Movement	Left	Thru	Right	Left	Thru	Right	Left	Thru	Right	Left	Thru	Right
Lane Width [ft]	12.00	12.00	12.00	12.00	12.00	12.00	12.00	12.00	12.00	12.00	12.00	12.00
No. of Lanes in Entry Pocket	3	0	1	2	0	2	2	0	2	3	0	0
Entry Pocket Length [ft]	380.00	100.00	250.00	295.00	100.00	290.00	265.00	100.00	330.00	395.00	100.00	100.00
No. of Lanes in Exit Pocket	0	0	1	0	0	0	0	0	0	0	0	0
Exit Pocket Length [ft]	0.00	0.00	49.21	0.00	0.00	0.00	0.00	0.00	0.00	0.00	0.00	0.00
Speed [mph]	30.00			40.00			40.00			40.00		
Grade [%]	0.00			0.00			0.00			0.00		
Curb Present	Yes			Yes			Yes			Yes		
Crosswalk	Yes			Yes			Yes			Yes		





**Volumes**

Name	Tassajara Road			Tassajara Road			Dublin Boulevard			Dublin Boulevard		
Base Volume Input [veh/h]	274	631	396	55	1338	134	102	210	148	521	663	75
Base Volume Adjustment Factor	1.0000	1.0000	1.0000	1.0000	1.0000	1.0000	1.0000	1.0000	1.0000	1.0000	1.0000	1.0000
Heavy Vehicles Percentage [%]	3.30	2.90	1.00	0.00	0.70	3.30	2.00	3.70	4.70	1.60	2.00	0.00
Proportion of CAVs [%]	0.00											
Growth Factor	1.0000	1.0000	1.0000	1.0000	1.0000	1.0000	1.0000	1.0000	1.0000	1.0000	1.0000	1.0000
In-Process Volume [veh/h]	0	0	0	0	0	0	0	0	0	0	0	0
Site-Generated Trips [veh/h]	0	0	0	0	0	0	0	0	0	0	0	0
Diverted Trips [veh/h]	0	0	0	0	0	0	0	0	0	0	0	0
Pass-by Trips [veh/h]	0	0	0	0	0	0	0	0	0	0	0	0
Existing Site Adjustment Volume [veh/h]	0	0	0	0	0	0	0	0	0	0	0	0
Other Volume [veh/h]	0	0	0	0	0	0	0	0	0	0	0	0
Right Turn on Red Volume [veh/h]	0	0	0	0	0	0	0	0	0	0	0	0
Total Hourly Volume [veh/h]	274	631	396	55	1338	134	102	210	148	521	663	75
Peak Hour Factor	0.9200	0.9200	0.9200	0.9200	0.9200	0.9200	0.9200	0.9200	0.9200	0.9200	0.9200	0.9200
Other Adjustment Factor	1.0000	1.0000	1.0000	1.0000	1.0000	1.0000	1.0000	1.0000	1.0000	1.0000	1.0000	1.0000
Total 15-Minute Volume [veh/h]	74	171	108	15	364	36	28	57	40	142	180	20
Total Analysis Volume [veh/h]	298	686	430	60	1454	146	111	228	161	566	721	82
Presence of On-Street Parking	No		No	No		No	No		No	No		No
On-Street Parking Maneuver Rate [/h]	0	0	0	0	0	0	0	0	0	0	0	0
Local Bus Stopping Rate [/h]	0	0	0	0	0	0	0	0	0	0	0	0
v_do, Outbound Pedestrian Volume crossing	1			2			2			1		
v_di, Inbound Pedestrian Volume crossing m	1			2			2			1		
v_co, Outbound Pedestrian Volume crossing	0			4			0			3		
v_ci, Inbound Pedestrian Volume crossing mi	0			3			0			4		
v_ab, Corner Pedestrian Volume [ped/h]	0			0			0			0		
Bicycle Volume [bicycles/h]	1			0			0			0		



**Intersection Settings**

Located in CBD	No
Signal Coordination Group	-
Cycle Length [s]	90
Active Pattern	Free Running (No Pattern)
Coordination Type	<i>Free Running</i>
Actuation Type	<i>Fully actuated</i>
Offset [s]	0.0
Offset Reference	Lead Green - Beginning of First Green
Permissive Mode	SingleBand
Lost time [s]	12.00

**Phasing & Timing (Basic)**

Control Type	Protecte	Permiss	Permiss	Protecte	Permiss	Permiss	Protecte	Permiss	Overlap	Protecte	Permiss	Permiss
Signal Group	3	8	0	7	4	0	5	2	2	1	6	0
Auxiliary Signal Groups									2,3			
Maximum Green [s]	20	35	0	20	35	0	20	35	35	20	35	0
Amber [s]	3.5	4.5	0.0	3.5	4.5	0.0	3.5	4.5	4.5	3.5	4.5	0.0
All red [s]	1.5	1.5	0.0	1.5	1.5	0.0	1.5	1.5	1.5	1.5	1.5	0.0
Walk [s]	0	4	0	0	4	0	0	0	0	0	4	0
Pedestrian Clearance [s]	0	29	0	0	42	0	0	0	0	0	42	0
Delayed Vehicle Green [s]	0.0	0.0	0.0	0.0	0.0	0.0	0.0	0.0	0.0	0.0	0.0	0.0
Rest In Walk		No			No			No			No	
I1, Start-Up Lost Time [s]	2.0	2.0	0.0	2.0	2.0	0.0	2.0	2.0	2.0	2.0	2.0	0.0
I2, Clearance Lost Time [s]	2.0	2.0	0.0	2.0	2.0	0.0	2.0	2.0	2.0	2.0	2.0	0.0
Detector Location [ft]	0.0	0.0	0.0	0.0	0.0	0.0	0.0	0.0	0.0	0.0	0.0	0.0
Detector Length [ft]	20.0	20.0	0.0	20.0	20.0	0.0	20.0	20.0	20.0	20.0	20.0	0.0
I, Upstream Filtering Factor	1.00	1.00	1.00	1.00	1.00	1.00	1.00	1.00	1.00	1.00	1.00	1.00

**Phasing & Timing: Free Running (No Pattern)**

Split [s]	0	0	0	0	0	0	0	0	0	0	0	0
Lead / Lag	Lead	-	-	Lead	-	-	Lead	-	-	Lead	-	-
Minimum Green [s]	16	15	0	15	15	0	16	16	16	16	15	0
Vehicle Extension [s]	2.0	4.0	0.0	2.0	4.0	0.0	2.0	3.0	3.0	2.0	3.0	0.0
Minimum Recall	No	Yes		No	Yes		No	No	No	No	No	
Maximum Recall	No	No		No	No		No	No	No	No	No	
Pedestrian Recall	No	No		No	No		No	No	No	No	No	

**Exclusive Pedestrian Phase**

Pedestrian Signal Group	0
Pedestrian Walk [s]	0
Pedestrian Clearance [s]	0



**Lane Group Calculations**

Lane Group	L	C	R	L	C	R	L	C	R	L	C	C
C, Cycle Length [s]	116	116	116	116	116	116	116	116	116	116	116	116
L, Total Lost Time per Cycle [s]	4.00	4.00	4.00	4.00	4.00	4.00	4.00	4.00	4.00	4.00	4.00	4.00
l1_p, Permitted Start-Up Lost Time [s]	0.00	0.00	0.00	0.00	0.00	0.00	0.00	0.00	0.00	0.00	0.00	0.00
l2, Clearance Lost Time [s]	2.00	2.00	2.00	2.00	2.00	2.00	2.00	2.00	0.00	2.00	2.00	2.00
g_i, Effective Green Time [s]	17	38	38	14	35	35	17	31	52	17	32	32
g / C, Green / Cycle	0.15	0.33	0.33	0.12	0.30	0.30	0.14	0.27	0.45	0.15	0.27	0.27
(v / s)_i Volume / Saturation Flow Rate	0.06	0.19	0.27	0.02	0.21	0.05	0.03	0.06	0.06	0.11	0.22	0.22
s, saturation flow rate [veh/h]	5134	3535	1579	3514	6863	2773	3459	3512	2752	5205	1870	1801
c, Capacity [veh/h]	749	1160	518	419	2070	836	492	946	1214	760	511	492
d1, Uniform Delay [s]	45.16	32.65	35.97	46.01	36.09	30.01	44.32	33.29	19.36	47.72	39.41	39.49
k, delay calibration	0.04	0.15	0.40	0.04	0.15	0.15	0.04	0.11	0.11	0.04	0.25	0.26
l, Upstream Filtering Factor	1.00	1.00	1.00	1.00	1.00	1.00	1.00	1.00	1.00	1.00	1.00	1.00
d2, Incremental Delay [s]	0.13	0.69	11.79	0.06	0.63	0.14	0.09	0.13	0.05	0.55	6.62	7.20
d3, Initial Queue Delay [s]	0.00	0.00	0.00	0.00	0.00	0.00	0.00	0.00	0.00	0.00	0.00	0.00
Rp, platoon ratio	1.00	1.00	1.00	1.00	1.00	1.00	1.00	1.00	1.00	1.00	1.00	1.00
PF, progression factor	1.00	1.00	1.00	1.00	1.00	1.00	1.00	1.00	1.00	1.00	1.00	1.00

**Lane Group Results**

X, volume / capacity	0.40	0.59	0.83	0.14	0.70	0.17	0.23	0.24	0.13	0.75	0.80	0.80
d, Delay for Lane Group [s/veh]	45.29	33.34	47.76	46.07	36.72	30.15	44.41	33.42	19.41	48.28	46.02	46.69
Lane Group LOS	D	C	D	D	D	C	D	C	B	D	D	D
Critical Lane Group	No	No	Yes	Yes	No	No	Yes	No	No	No	No	Yes
50th-Percentile Queue Length [veh/ln]	2.62	8.13	12.77	0.77	8.97	1.50	1.41	2.49	1.27	5.18	11.46	11.22
50th-Percentile Queue Length [ft/ln]	65.47	203.29	319.33	19.28	224.33	37.50	35.15	62.35	31.75	129.54	286.56	280.44
95th-Percentile Queue Length [veh/ln]	4.71	12.81	18.63	1.39	13.89	2.70	2.53	4.49	2.29	8.92	17.01	16.71
95th-Percentile Queue Length [ft/ln]	117.84	320.20	465.86	34.71	347.15	67.50	63.26	112.23	57.16	222.88	425.37	417.76



**Movement, Approach, & Intersection Results**

d_M, Delay for Movement [s/veh]	45.29	33.34	47.76	46.07	36.72	30.15	44.41	33.42	19.41	48.28	46.31	46.69
Movement LOS	D	C	D	D	D	C	D	C	B	D	D	D
d_A, Approach Delay [s/veh]	40.24			36.48			31.35			47.15		
Approach LOS	D			D			C			D		
d_I, Intersection Delay [s/veh]	39.99											
Intersection LOS	D											
Intersection V/C	0.603											

**Emissions**

Vehicle Miles Traveled [mph]	61.13	140.72	88.21	17.30	419.31	42.10	97.60	200.48	141.57	680.99	490.33	475.80
Stops [stops/h]	242.80	502.61	394.75	47.68	1109.28	92.72	86.89	154.15	78.51	480.43	354.25	346.68
Fuel consumption [US gal/h]	6.60	13.22	9.99	1.65	36.78	3.31	5.35	10.25	6.48	34.67	24.86	24.21
CO [g/h]	461.62	924.36	698.35	115.38	2570.93	231.71	374.17	716.23	452.82	2423.64	1737.74	1692.02
NOx [g/h]	89.81	179.85	135.87	22.45	500.21	45.08	72.80	139.35	88.10	471.55	338.10	329.21
VOC [g/h]	106.98	214.23	161.85	26.74	595.84	53.70	86.72	165.99	104.95	561.70	402.74	392.14

**Other Modes**

g_Walk,mi, Effective Walk Time [s]	-6.0		8.0		8.0		8.0	
M_corner, Corner Circulation Area [ft <sup>2</sup> /ped]	0.00		0.00		0.00		0.00	
M_CW, Crosswalk Circulation Area [ft <sup>2</sup> /ped]	0.00		0.00		0.00		0.00	
d_p, Pedestrian Delay [s]	64.40		50.52		50.52		50.52	
I_p,int, Pedestrian LOS Score for Intersectio	3.341		3.311		3.104		3.079	
Crosswalk LOS	C		C		C		C	
s_b, Saturation Flow Rate of the bicycle lane	2000		2000		2000		2000	
c_b, Capacity of the bicycle lane [bicycles/h]	601		601		601		601	
d_b, Bicycle Delay [s]	28.52		28.50		28.50		28.50	
I_b,int, Bicycle LOS Score for Intersection	2.726		2.244		1.972		2.689	
Bicycle LOS	B		B		A		B	

**Sequence**

Ring 1	1	2	3	4	-	-	-	-	-	-	-	-	-	-	-
Ring 2	5	6	7	8	-	-	-	-	-	-	-	-	-	-	-
Ring 3	-	-	-	-	-	-	-	-	-	-	-	-	-	-	-
Ring 4	-	-	-	-	-	-	-	-	-	-	-	-	-	-	-



**Intersection Level Of Service Report**  
**Intersection 4: Tassajara Road & I-580 WB Ramps**

Control Type:	Signalized	Delay (sec / veh):	13.4
Analysis Method:	HCM 7th Edition	Level Of Service:	B
Analysis Period:	15 minutes	Volume to Capacity (v/c):	0.631

**Intersection Setup**

Name	Tassajara Road		Tassajara Road		I-580 WB Ramps	
Approach	Northbound		Southbound		Westbound	
Lane Configuration	↑↑		↑↑↑		↔↔↔↔	
Turning Movement	Thru	Right	Left	Thru	Left	Right
Lane Width [ft]	12.00	12.00	12.00	12.00	12.00	12.00
No. of Lanes in Entry Pocket	0	0	0	0	1	1
Entry Pocket Length [ft]	100.00	100.00	100.00	100.00	100.00	100.00
No. of Lanes in Exit Pocket	0	1	0	0	0	0
Exit Pocket Length [ft]	0.00	49.21	0.00	0.00	0.00	0.00
Speed [mph]	30.00		30.00		30.00	
Grade [%]	0.00		0.00		0.00	
Curb Present	No		No		No	
Crosswalk	Yes		Yes		Yes	



**Volumes**

Name	Tassajara Road		Tassajara Road		I-580 WB Ramps	
Base Volume Input [veh/h]	1345	0	0	937	631	354
Base Volume Adjustment Factor	1.0000	1.0000	1.0000	1.0000	1.0000	1.0000
Heavy Vehicles Percentage [%]	2.30	2.00	2.00	1.80	2.90	4.00
Proportion of CAVs [%]	0.00					
Growth Factor	1.0000	1.0000	1.0000	1.0000	1.0000	1.0000
In-Process Volume [veh/h]	0	0	0	0	0	0
Site-Generated Trips [veh/h]	0	0	0	0	0	0
Diverted Trips [veh/h]	0	0	0	0	0	0
Pass-by Trips [veh/h]	0	0	0	0	0	0
Existing Site Adjustment Volume [veh/h]	0	0	0	0	0	0
Other Volume [veh/h]	0	0	0	0	0	0
Right Turn on Red Volume [veh/h]	0	0	0	0	0	0
Total Hourly Volume [veh/h]	1345	0	0	937	631	354
Peak Hour Factor	0.9800	1.0000	1.0000	0.9800	0.9800	0.9800
Other Adjustment Factor	1.0000	1.0000	1.0000	1.0000	1.0000	1.0000
Total 15-Minute Volume [veh/h]	343	0	0	239	161	90
Total Analysis Volume [veh/h]	1372	0	0	956	644	361
Presence of On-Street Parking	No	No	No	No	No	No
On-Street Parking Maneuver Rate [/h]	0	0	0	0	0	0
Local Bus Stopping Rate [/h]	0	0	0	0	0	0
v_do, Outbound Pedestrian Volume crossing	0		0		0	
v_di, Inbound Pedestrian Volume crossing m	0		0		0	
v_co, Outbound Pedestrian Volume crossing	0		0		0	
v_ci, Inbound Pedestrian Volume crossing mi	0		0		0	
v_ab, Corner Pedestrian Volume [ped/h]	0		0		0	
Bicycle Volume [bicycles/h]	0		0		0	



**Intersection Settings**

Located in CBD	No
Signal Coordination Group	-
Cycle Length [s]	60
Active Pattern	Pattern 1
Coordination Type	Time of Day Pattern Coordinated
Actuation Type	Fully actuated
Offset [s]	20.0
Offset Reference	Beginning of First Yellow
Permissive Mode	SingleBand
Lost time [s]	6.00

**Phasing & Timing (Basic)**

Control Type	Permissive	Permissive	Permissive	Permissive	Split	Split
Signal Group	6	0	0	2	4	0
Auxiliary Signal Groups						
Maximum Green [s]	40	0	0	40	20	0
Amber [s]	4.9	0.0	0.0	4.9	4.4	0.0
All red [s]	1.0	0.0	0.0	1.0	1.0	0.0
Walk [s]	5	0	0	0	0	0
Pedestrian Clearance [s]	16	0	0	0	0	0
Delayed Vehicle Green [s]	0.0	0.0	0.0	0.0	0.0	0.0
Rest In Walk	No			No	No	
I1, Start-Up Lost Time [s]	2.0	0.0	0.0	2.0	2.0	0.0
I2, Clearance Lost Time [s]	3.9	0.0	0.0	3.9	3.4	0.0
Detector Location [ft]	0.0	0.0	0.0	0.0	0.0	0.0
Detector Length [ft]	20.0	0.0	0.0	20.0	20.0	0.0
I, Upstream Filtering Factor	1.00	1.00	1.00	1.00	1.00	1.00

**Phasing & Timing: Pattern 1**

Split [s]	38	0	0	38	22	0
Lead / Lag	-	-	-	-	Lead	-
Minimum Green [s]	7	0	0	7	4	0
Vehicle Extension [s]	3.0	0.0	0.0	3.0	2.0	0.0
Minimum Recall	No			No	No	
Maximum Recall	Yes			Yes	No	
Pedestrian Recall	Yes			No	No	

**Exclusive Pedestrian Phase**

Pedestrian Signal Group	0
Pedestrian Walk [s]	0
Pedestrian Clearance [s]	0



**Lane Group Calculations**

Lane Group	C	C	L	R
C, Cycle Length [s]	66	66	66	66
L, Total Lost Time per Cycle [s]	5.90	5.90	5.40	5.40
l1_p, Permitted Start-Up Lost Time [s]	0.00	0.00	0.00	0.00
l2, Clearance Lost Time [s]	3.90	3.90	3.40	3.40
g_i, Effective Green Time [s]	40	40	15	15
g / C, Green / Cycle	0.61	0.61	0.22	0.22
(v / s)_i Volume / Saturation Flow Rate	0.39	0.19	0.19	0.13
s, saturation flow rate [veh/h]	3552	5102	3434	2768
c, Capacity [veh/h]	2151	3090	767	618
d1, Uniform Delay [s]	8.37	6.32	24.52	22.91
k, delay calibration	0.50	0.50	0.04	0.04
l, Upstream Filtering Factor	1.00	1.00	1.00	1.00
d2, Incremental Delay [s]	1.46	0.26	0.97	0.33
d3, Initial Queue Delay [s]	0.00	0.00	0.00	0.00
Rp, platoon ratio	1.00	1.00	1.00	1.00
PF, progression factor	1.00	1.00	1.00	1.00

**Lane Group Results**

X, volume / capacity	0.64	0.31	0.84	0.58
d, Delay for Lane Group [s/veh]	9.83	6.58	25.50	23.24
Lane Group LOS	A	A	C	C
Critical Lane Group	Yes	No	Yes	No
50th-Percentile Queue Length [veh/ln]	5.28	1.77	4.61	2.39
50th-Percentile Queue Length [ft/ln]	132.05	44.36	115.21	59.68
95th-Percentile Queue Length [veh/ln]	9.05	3.19	8.13	4.30
95th-Percentile Queue Length [ft/ln]	226.27	79.85	203.23	107.43



**Movement, Approach, & Intersection Results**

d_M, Delay for Movement [s/veh]	9.83	0.00	0.00	6.58	25.50	23.24
Movement LOS	A			A	C	C
d_A, Approach Delay [s/veh]	9.83		6.58		24.68	
Approach LOS	A		A		C	
d_I, Intersection Delay [s/veh]	13.38					
Intersection LOS	B					
Intersection V/C	0.631					

**Emissions**

Vehicle Miles Traveled [mph]	231.03	196.10	52.08	29.20
Stops [stops/h]	576.30	290.43	502.83	260.48
Fuel consumption [US gal/h]	15.44	10.96	8.26	4.35
CO [g/h]	1079.24	765.98	577.63	303.93
NOx [g/h]	209.98	149.03	112.39	59.13
VOC [g/h]	250.12	177.52	133.87	70.44

**Other Modes**

g_Walk,mi, Effective Walk Time [s]	16.6	16.6	9.0
M_corner, Corner Circulation Area [ft <sup>2</sup> /ped]	0.00	0.00	0.00
M_CW, Crosswalk Circulation Area [ft <sup>2</sup> /ped]	0.00	0.00	0.00
d_p, Pedestrian Delay [s]	18.48	18.48	24.61
I_p,int, Pedestrian LOS Score for Intersectio	2.854	2.798	2.482
Crosswalk LOS	C	C	B
s_b, Saturation Flow Rate of the bicycle lane	2000	2000	2000
c_b, Capacity of the bicycle lane [bicycles/h]	973	973	503
d_b, Bicycle Delay [s]	8.70	8.70	18.48
I_b,int, Bicycle LOS Score for Intersection	2.692	2.085	1.560
Bicycle LOS	B	B	A

**Sequence**

Ring 1	-	2	-	4	-	-	-	-	-	-	-	-	-	-	-	-
Ring 2	-	6	-	-	-	-	-	-	-	-	-	-	-	-	-	-
Ring 3	-	-	-	-	-	-	-	-	-	-	-	-	-	-	-	-
Ring 4	-	-	-	-	-	-	-	-	-	-	-	-	-	-	-	-



**Intersection Level Of Service Report**  
**Intersection 5: Santa Rita Rd & I-580 EB Ramps/Pimlico Dr**

Control Type:	Signalized	Delay (sec / veh):	32.5
Analysis Method:	HCM 7th Edition	Level Of Service:	C
Analysis Period:	15 minutes	Volume to Capacity (v/c):	0.753

**Intersection Setup**

Name	Santa Rita Road			Tassajara Road			I-580 EB Ramps			Pimlico Drive		
Approach	Northbound			Southbound			Eastbound			Westbound		
Lane Configuration	↑			↵			↵↑			↵↵↵↑		
Turning Movement	Left	Thru	Right	Left	Thru	Right	Left	Thru	Right	Left	Thru	Right
Lane Width [ft]	12.00	12.00	12.00	12.00	12.00	12.00	12.00	12.00	12.00	12.00	12.00	12.00
No. of Lanes in Entry Pocket	0	0	1	1	0	0	1	0	0	2	0	1
Entry Pocket Length [ft]	100.00	100.00	250.00	425.00	100.00	100.00	625.00	100.00	100.00	200.00	100.00	250.00
No. of Lanes in Exit Pocket	0	0	0	0	0	2	0	0	0	0	0	0
Exit Pocket Length [ft]	0.00	0.00	0.00	0.00	0.00	49.21	0.00	0.00	0.00	0.00	0.00	0.00
Speed [mph]	30.00			30.00			30.00			30.00		
Grade [%]	0.00			0.00			0.00			0.00		
Curb Present	No			No			No			No		
Crosswalk	Yes			No			Yes			Yes		



**Volumes**

Name	Santa Rita Road			Tassajara Road			I-580 EB Ramps			Pimlico Drive		
Base Volume Input [veh/h]	0	985	84	164	1235	0	765	128	0	142	0	291
Base Volume Adjustment Factor	1.0000	1.0000	1.0000	1.0000	1.0000	1.0000	1.0000	1.0000	1.0000	1.0000	1.0000	1.0000
Heavy Vehicles Percentage [%]	2.00	3.30	2.40	1.80	2.30	2.00	2.10	2.40	2.00	0.70	2.00	2.40
Proportion of CAVs [%]	0.00											
Growth Factor	1.0000	1.0000	1.0000	1.0000	1.0000	1.0000	1.0000	1.0000	1.0000	1.0000	1.0000	1.0000
In-Process Volume [veh/h]	0	0	0	0	0	0	0	0	0	0	0	0
Site-Generated Trips [veh/h]	0	0	0	0	0	0	0	0	0	0	0	0
Diverted Trips [veh/h]	0	0	0	0	0	0	0	0	0	0	0	0
Pass-by Trips [veh/h]	0	0	0	0	0	0	0	0	0	0	0	0
Existing Site Adjustment Volume [veh/h]	0	0	0	0	0	0	0	0	0	0	0	0
Other Volume [veh/h]	0	0	0	0	0	0	0	0	0	0	0	0
Right Turn on Red Volume [veh/h]	0	0	0	0	0	0	0	0	0	0	0	0
Total Hourly Volume [veh/h]	0	985	84	164	1235	0	765	128	0	142	0	291
Peak Hour Factor	1.0000	0.9600	0.9600	0.9600	0.9600	1.0000	0.9600	0.9600	1.0000	0.9600	1.0000	0.9600
Other Adjustment Factor	1.0000	1.0000	1.0000	1.0000	1.0000	1.0000	1.0000	1.0000	1.0000	1.0000	1.0000	1.0000
Total 15-Minute Volume [veh/h]	0	257	22	43	322	0	199	33	0	37	0	76
Total Analysis Volume [veh/h]	0	1026	88	171	1286	0	797	133	0	148	0	303
Presence of On-Street Parking	No		No	No		No	No		No	No		No
On-Street Parking Maneuver Rate [/h]	0	0	0	0	0	0	0	0	0	0	0	0
Local Bus Stopping Rate [/h]	0	0	0	0	0	0	0	0	0	0	0	0
v_do, Outbound Pedestrian Volume crossing	5			0			5			0		
v_di, Inbound Pedestrian Volume crossing m	5			0			5			0		
v_co, Outbound Pedestrian Volume crossing	0			2			2			1		
v_ci, Inbound Pedestrian Volume crossing mi	1			2			2			0		
v_ab, Corner Pedestrian Volume [ped/h]	0			0			0			0		
Bicycle Volume [bicycles/h]	0			0			0			0		



**Intersection Settings**

Located in CBD	No
Signal Coordination Group	-
Cycle Length [s]	120
Active Pattern	Pattern 1
Coordination Type	Time of Day Pattern Coordinated
Actuation Type	Fully actuated
Offset [s]	20.0
Offset Reference	Lead Green - Beginning of First Green
Permissive Mode	SingleBand
Lost time [s]	12.00

**Phasing & Timing (Basic)**

Control Type	Permiss	Permiss	Permiss	Protecte	Permiss	Permiss	Protecte	Permiss	Permiss	Permiss	Permiss	Overlap
Signal Group	0	6	0	5	2	0	3	8	0	7	0	4
Auxiliary Signal Groups												4,5
Maximum Green [s]	0	30	0	20	30	0	35	20	0	20	0	20
Amber [s]	0.0	4.4	0.0	3.0	4.4	0.0	4.4	4.4	0.0	3.5	0.0	3.5
All red [s]	0.0	1.0	0.0	1.0	1.0	0.0	1.0	1.0	0.0	1.0	0.0	1.0
Walk [s]	0	5	0	0	5	0	0	5	0	0	0	0
Pedestrian Clearance [s]	0	25	0	0	8	0	0	25	0	0	0	0
Delayed Vehicle Green [s]	0.0	0.0	0.0	0.0	0.0	0.0	0.0	0.0	0.0	0.0	0.0	0.0
Rest In Walk		No			No			No		No		
I1, Start-Up Lost Time [s]	0.0	2.0	0.0	2.0	2.0	0.0	2.0	2.0	0.0	2.0	0.0	2.0
I2, Clearance Lost Time [s]	0.0	3.4	0.0	2.0	3.4	0.0	3.4	3.4	0.0	2.5	0.0	2.5
Detector Location [ft]	0.0	0.0	0.0	0.0	0.0	0.0	0.0	0.0	0.0	0.0	0.0	0.0
Detector Length [ft]	0.0	20.0	0.0	20.0	20.0	0.0	20.0	20.0	0.0	20.0	0.0	0.0
I, Upstream Filtering Factor	1.00	1.00	1.00	1.00	1.00	1.00	1.00	1.00	1.00	1.00	1.00	1.00

**Phasing & Timing: Pattern 1**

Split [s]	0	41	0	25	66	0	40	36	0	18	0	14
Lead / Lag	-	-	-	Lead	-	-	Lead	-	-	Lead	-	-
Minimum Green [s]	0	7	0	5	7	0	5	5	0	5	0	5
Vehicle Extension [s]	0.0	3.0	0.0	3.0	3.0	0.0	3.0	2.0	0.0	3.0	0.0	2.0
Minimum Recall		No		No	No		No	No		No		No
Maximum Recall		Yes		No	Yes		No	No		No		No
Pedestrian Recall		No		No	Yes		No	No		No		No

**Exclusive Pedestrian Phase**

Pedestrian Signal Group	0
Pedestrian Walk [s]	0
Pedestrian Clearance [s]	0



**Lane Group Calculations**

Lane Group	C	C	L	C	L	C	L	R
C, Cycle Length [s]	120	120	120	120	120	120	120	120
L, Total Lost Time per Cycle [s]	5.40	5.40	4.00	5.40	5.40	5.40	4.50	4.00
l1_p, Permitted Start-Up Lost Time [s]	0.00	0.00	0.00	0.00	0.00	0.00	0.00	0.00
l2, Clearance Lost Time [s]	3.40	3.40	2.00	3.40	3.40	3.40	2.50	0.00
g_i, Effective Green Time [s]	51	51	14	68	31	29	7	24
g / C, Green / Cycle	0.42	0.42	0.12	0.57	0.25	0.24	0.06	0.20
(v / s)_i Volume / Saturation Flow Rate	0.21	0.16	0.10	0.36	0.23	0.07	0.04	0.11
s, saturation flow rate [veh/h]	4053	1752	1784	3552	3456	1864	3495	2804
c, Capacity [veh/h]	1710	739	206	2027	878	449	213	562
d1, Uniform Delay [s]	25.24	23.82	51.91	17.33	43.36	37.19	55.23	42.96
k, delay calibration	0.50	0.50	0.13	0.50	0.11	0.04	0.11	0.04
l, Upstream Filtering Factor	1.00	1.00	1.00	1.00	1.00	1.00	1.00	1.00
d2, Incremental Delay [s]	1.00	1.46	9.64	1.53	3.97	0.14	4.08	0.30
d3, Initial Queue Delay [s]	0.00	0.00	0.00	0.00	0.00	0.00	0.00	0.00
Rp, platoon ratio	1.00	1.00	1.00	1.00	1.00	1.00	1.00	1.00
PF, progression factor	1.00	1.00	1.00	1.00	1.00	1.00	1.00	1.00

**Lane Group Results**

X, volume / capacity	0.49	0.38	0.83	0.63	0.91	0.30	0.70	0.54
d, Delay for Lane Group [s/veh]	26.24	25.29	61.55	18.86	47.33	37.33	59.31	43.26
Lane Group LOS	C	C	E	B	D	D	E	D
Critical Lane Group	No	No	No	Yes	Yes	No	No	Yes
50th-Percentile Queue Length [veh/ln]	5.91	5.73	5.58	11.95	11.86	3.22	2.32	4.06
50th-Percentile Queue Length [ft/ln]	147.68	143.16	139.51	298.78	296.52	80.61	57.90	101.45
95th-Percentile Queue Length [veh/ln]	9.89	9.65	9.45	17.62	17.51	5.80	4.17	7.30
95th-Percentile Queue Length [ft/ln]	247.33	241.28	236.36	440.52	437.72	145.10	104.22	182.61

**Movement, Approach, & Intersection Results**

d_M, Delay for Movement [s/veh]	0.00	26.06	25.29	61.55	18.86	0.00	47.33	37.33	0.00	59.31	0.00	43.26
Movement LOS		C	C	E	B		D	D		E		D
d_A, Approach Delay [s/veh]	26.00			23.87			45.90			48.53		
Approach LOS	C			C			D			D		
d_I, Intersection Delay [s/veh]	32.47											
Intersection LOS	C											
Intersection V/C	0.753											

**Emissions**

Vehicle Miles Traveled [mph]	82.40	27.47	28.79	216.55	110.59	18.45	12.63	25.86
Stops [stops/h]	531.82	171.85	167.47	717.32	711.88	96.77	139.01	243.56
Fuel consumption [US gal/h]	10.79	3.51	4.25	17.81	16.16	2.30	3.07	5.08
CO [g/h]	754.37	245.59	297.22	1245.18	1129.66	161.09	214.87	354.93
NOx [g/h]	146.77	47.78	57.83	242.27	219.79	31.34	41.81	69.06
VOC [g/h]	174.83	56.92	68.88	288.58	261.81	37.33	49.80	82.26

**Other Modes**

g_Walk,mi, Effective Walk Time [s]	9.0	0.0	9.0	9.0
M_corner, Corner Circulation Area [ft <sup>2</sup> /ped]	0.00	0.00	0.00	0.00
M_CW, Crosswalk Circulation Area [ft <sup>2</sup> /ped]	653.31	0.00	0.00	0.00
d_p, Pedestrian Delay [s]	51.32	0.00	51.32	51.32
I_p,int, Pedestrian LOS Score for Intersectio	2.882	0.000	2.373	2.479
Crosswalk LOS	C	F	B	B
s_b, Saturation Flow Rate of the bicycle lane	2000	2000	2000	2000
c_b, Capacity of the bicycle lane [bicycles/h]	594	1010	510	225
d_b, Bicycle Delay [s]	29.66	14.69	33.28	47.24
I_b,int, Bicycle LOS Score for Intersection	2.019	2.762	3.094	1.560
Bicycle LOS	B	C	C	A

**Sequence**

Ring 1	-	2	3	4	-	-	-	-	-	-	-	-	-	-	-
Ring 2	5	6	7	8	-	-	-	-	-	-	-	-	-	-	-
Ring 3	-	-	-	-	-	-	-	-	-	-	-	-	-	-	-
Ring 4	-	-	-	-	-	-	-	-	-	-	-	-	-	-	-

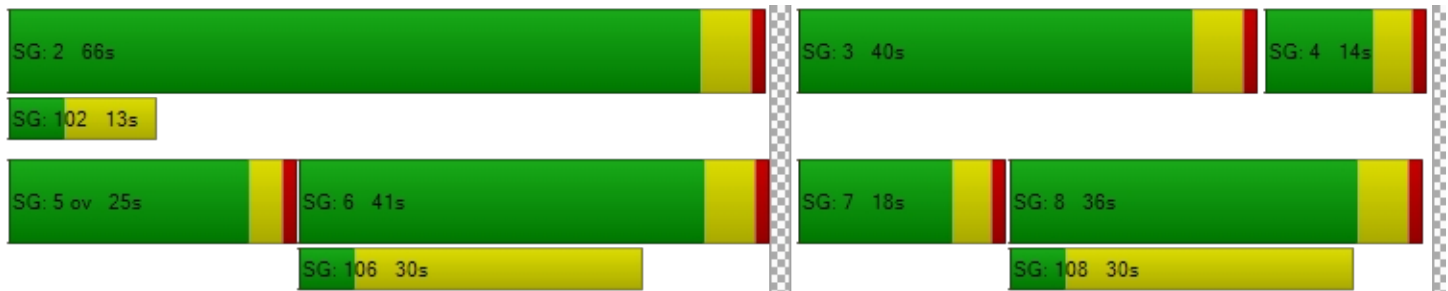

**Intersection Level Of Service Report**  
**Intersection 6: Tassajara Road & Fallon Road**

Control Type:	Signalized	Delay (sec / veh):	22.8
Analysis Method:	HCM 7th Edition	Level Of Service:	C
Analysis Period:	15 minutes	Volume to Capacity (v/c):	0.666

**Intersection Setup**

Name	Fallon Road			Fallon Road			Tassajara Road			Syrah Drive		
Approach	Northbound			Southbound			Eastbound			Westbound		
Lane Configuration												
Turning Movement	Left	Thru	Right	Left	Thru	Right	Left	Thru	Right	Left	Thru	Right
Lane Width [ft]	12.00	12.00	12.00	12.00	12.00	12.00	12.00	12.00	12.00	12.00	12.00	12.00
No. of Lanes in Entry Pocket	1	0	1	1	0	2	1	0	1	1	0	1
Entry Pocket Length [ft]	175.00	100.00	175.00	175.00	100.00	225.00	475.00	100.00	175.00	100.00	100.00	100.00
No. of Lanes in Exit Pocket	0	0	0	0	0	0	0	0	0	0	0	0
Exit Pocket Length [ft]	0.00	0.00	0.00	0.00	0.00	0.00	0.00	0.00	0.00	0.00	0.00	0.00
Speed [mph]	30.00			30.00			30.00			30.00		
Grade [%]	0.00			0.00			0.00			0.00		
Curb Present	No			No			No			No		
Crosswalk	Yes			Yes			Yes			Yes		



**Volumes**

Name	Fallon Road			Fallon Road			Tassajara Road			Syrah Drive		
Base Volume Input [veh/h]	203	297	12	2	342	513	228	12	206	18	34	10
Base Volume Adjustment Factor	1.0000	1.0000	1.0000	1.0000	1.0000	1.0000	1.0000	1.0000	1.0000	1.0000	1.0000	1.0000
Heavy Vehicles Percentage [%]	1.00	1.70	0.00	0.00	0.60	0.20	1.40	0.00	0.50	0.00	0.00	0.00
Proportion of CAVs [%]	0.00											
Growth Factor	1.0000	1.0000	1.0000	1.0000	1.0000	1.0000	1.0000	1.0000	1.0000	1.0000	1.0000	1.0000
In-Process Volume [veh/h]	0	0	0	0	0	0	0	0	0	0	0	0
Site-Generated Trips [veh/h]	0	0	0	0	0	0	0	0	0	0	0	0
Diverted Trips [veh/h]	0	0	0	0	0	0	0	0	0	0	0	0
Pass-by Trips [veh/h]	0	0	0	0	0	0	0	0	0	0	0	0
Existing Site Adjustment Volume [veh/h]	0	0	0	0	0	0	0	0	0	0	0	0
Other Volume [veh/h]	0	0	0	0	0	0	0	0	0	0	0	0
Right Turn on Red Volume [veh/h]	0	0	0	0	0	0	0	0	0	0	0	0
Total Hourly Volume [veh/h]	203	297	12	2	342	513	228	12	206	18	34	10
Peak Hour Factor	0.7800	0.7800	0.7800	0.7800	0.7800	0.7800	0.7800	0.7800	0.7800	0.7800	0.7800	0.7800
Other Adjustment Factor	1.0000	1.0000	1.0000	1.0000	1.0000	1.0000	1.0000	1.0000	1.0000	1.0000	1.0000	1.0000
Total 15-Minute Volume [veh/h]	65	95	4	1	110	164	73	4	66	6	11	3
Total Analysis Volume [veh/h]	260	381	15	3	438	658	292	15	264	23	44	13
Presence of On-Street Parking	No		No	No		No	No		No	No		No
On-Street Parking Maneuver Rate [/h]	0	0	0	0	0	0	0	0	0	0	0	0
Local Bus Stopping Rate [/h]	0	0	0	0	0	0	0	0	0	0	0	0
v_do, Outbound Pedestrian Volume crossing	1			0			0			0		
v_di, Inbound Pedestrian Volume crossing m	0			0			1			0		
v_co, Outbound Pedestrian Volume crossing	0			0			1			0		
v_ci, Inbound Pedestrian Volume crossing mi	0			1			0			0		
v_ab, Corner Pedestrian Volume [ped/h]	0			0			0			0		
Bicycle Volume [bicycles/h]	0			0			0			0		





**Intersection Settings**

Located in CBD	No
Signal Coordination Group	-
Cycle Length [s]	90
Active Pattern	Free Running (No Pattern)
Coordination Type	<i>Free Running</i>
Actuation Type	<i>Fully actuated</i>
Offset [s]	0.0
Offset Reference	Lead Green - Beginning of First Green
Permissive Mode	SingleBand
Lost time [s]	12.00

**Phasing & Timing (Basic)**

Control Type	Protecte	Permiss	Permiss	Protecte	Permiss	Permiss	Protecte	Permiss	Permiss	Protecte	Permiss	Permiss
Signal Group	3	8	0	7	4	0	5	2	0	1	6	0
Auxiliary Signal Groups												
Maximum Green [s]	25	50	0	25	50	0	35	30	0	20	30	0
Amber [s]	3.5	4.8	0.0	3.5	4.8	0.0	3.5	5.0	0.0	3.0	3.6	0.0
All red [s]	1.0	1.0	0.0	1.0	1.0	0.0	1.0	1.0	0.0	1.0	1.0	0.0
Walk [s]	0	4	0	0	0	0	0	4	0	0	3	0
Pedestrian Clearance [s]	0	25	0	0	0	0	0	28	0	0	36	0
Delayed Vehicle Green [s]	0.0	0.0	0.0	0.0	0.0	0.0	0.0	0.0	0.0	0.0	0.0	0.0
Rest In Walk		No			No			No			No	
I1, Start-Up Lost Time [s]	2.0	2.0	0.0	2.0	2.0	0.0	2.0	2.0	0.0	2.0	2.0	0.0
I2, Clearance Lost Time [s]	2.0	2.0	0.0	2.0	2.0	0.0	2.0	2.0	0.0	2.0	2.0	0.0
Detector Location [ft]	0.0	0.0	0.0	0.0	0.0	0.0	0.0	0.0	0.0	0.0	0.0	0.0
Detector Length [ft]	0.0	0.0	0.0	0.0	0.0	0.0	0.0	0.0	0.0	0.0	0.0	0.0
I, Upstream Filtering Factor	1.00	1.00	1.00	1.00	1.00	1.00	1.00	1.00	1.00	1.00	1.00	1.00

**Phasing & Timing: Free Running (No Pattern)**

Split [s]	0	0	0	0	0	0	0	0	0	0	0	0
Lead / Lag	Lead	-	-	Lead	-	-	Lead	-	-	Lead	-	-
Minimum Green [s]	9	10	0	9	10	0	11	8	0	12	9	0
Vehicle Extension [s]	3.0	3.0	0.0	3.0	3.0	0.0	3.0	3.0	0.0	3.0	3.0	0.0
Minimum Recall	No	No		No	No		Yes	No		No	No	
Maximum Recall	No	No		No	No		No	No		No	No	
Pedestrian Recall	No	No		No	No		No	No		No	No	

**Exclusive Pedestrian Phase**

Pedestrian Signal Group	0
Pedestrian Walk [s]	0
Pedestrian Clearance [s]	0



**Lane Group Calculations**

Lane Group	L	C	R	L	C	R	L	C	R	L	C	R
C, Cycle Length [s]	70	70	70	70	70	70	70	70	70	70	70	70
L, Total Lost Time per Cycle [s]	4.00	4.00	4.00	4.00	4.00	4.00	4.00	4.00	4.00	4.00	4.00	4.00
l1_p, Permitted Start-Up Lost Time [s]	0.00	0.00	0.00	0.00	0.00	0.00	0.00	0.00	0.00	0.00	0.00	0.00
l2, Clearance Lost Time [s]	2.00	2.00	2.00	2.00	2.00	2.00	2.00	2.00	2.00	2.00	2.00	2.00
g_i, Effective Green Time [s]	13	33	33	1	22	22	11	16	16	4	9	9
g / C, Green / Cycle	0.18	0.47	0.47	0.01	0.31	0.31	0.16	0.22	0.22	0.06	0.12	0.12
(v / s)_i Volume / Saturation Flow Rate	0.14	0.11	0.01	0.00	0.12	0.23	0.08	0.01	0.16	0.01	0.02	0.01
s, saturation flow rate [veh/h]	1795	3569	1615	1810	3600	2854	3475	1900	1606	1810	1900	1615
c, Capacity [veh/h]	325	1694	766	26	1109	879	565	422	357	112	231	196
d1, Uniform Delay [s]	27.64	10.90	9.82	34.29	19.22	21.94	26.98	21.50	25.52	31.40	27.85	27.43
k, delay calibration	0.11	0.11	0.11	0.11	0.11	0.11	0.11	0.11	0.11	0.11	0.11	0.11
l, Upstream Filtering Factor	1.00	1.00	1.00	1.00	1.00	1.00	1.00	1.00	1.00	1.00	1.00	1.00
d2, Incremental Delay [s]	4.55	0.07	0.01	1.92	0.23	1.30	0.73	0.03	3.03	0.89	0.40	0.14
d3, Initial Queue Delay [s]	0.00	0.00	0.00	0.00	0.00	0.00	0.00	0.00	0.00	0.00	0.00	0.00
Rp, platoon ratio	1.00	1.00	1.00	1.00	1.00	1.00	1.00	1.00	1.00	1.00	1.00	1.00
PF, progression factor	1.00	1.00	1.00	1.00	1.00	1.00	1.00	1.00	1.00	1.00	1.00	1.00

**Lane Group Results**

X, volume / capacity	0.80	0.22	0.02	0.11	0.40	0.75	0.52	0.04	0.74	0.20	0.19	0.07
d, Delay for Lane Group [s/veh]	32.20	10.96	9.83	36.22	19.45	23.25	27.71	21.54	28.55	32.29	28.25	27.57
Lane Group LOS	C	B	A	D	B	C	C	C	C	C	C	C
Critical Lane Group	Yes	No	No	No	No	Yes	No	No	Yes	Yes	No	No
50th-Percentile Queue Length [veh/ln]	4.40	1.59	0.11	0.06	2.69	4.71	2.21	0.19	4.19	0.39	0.67	0.20
50th-Percentile Queue Length [ft/ln]	110.03	39.80	2.85	1.58	67.23	117.76	55.13	4.76	104.80	9.69	16.73	4.88
95th-Percentile Queue Length [veh/ln]	7.84	2.87	0.21	0.11	4.84	8.27	3.97	0.34	7.55	0.70	1.20	0.35
95th-Percentile Queue Length [ft/ln]	196.05	71.63	5.13	2.84	121.01	206.74	99.24	8.56	188.65	17.44	30.12	8.78



**Movement, Approach, & Intersection Results**

d_M, Delay for Movement [s/veh]	32.20	10.96	9.83	36.22	19.45	23.25	27.71	21.54	28.55	32.29	28.25	27.57
Movement LOS	C	B	A	D	B	C	C	C	C	C	C	C
d_A, Approach Delay [s/veh]	19.35			21.77			27.94			29.30		
Approach LOS	B			C			C			C		
d_I, Intersection Delay [s/veh]	22.83											
Intersection LOS	C											
Intersection V/C	0.666											

**Emissions**

Vehicle Miles Traveled [mph]	24.78	36.31	1.43	0.33	47.54	71.42	37.66	1.93	34.05	0.83	1.58	0.47
Stops [stops/h]	225.20	162.91	5.84	3.23	275.20	482.05	225.68	9.74	214.51	19.83	34.25	9.98
Fuel consumption [US gal/h]	3.97	3.24	0.12	0.05	5.21	8.72	4.44	0.20	4.12	0.29	0.51	0.15
CO [g/h]	277.35	226.81	8.47	3.73	364.28	609.27	310.62	13.92	288.03	20.60	35.45	10.29
NOx [g/h]	53.96	44.13	1.65	0.73	70.87	118.54	60.44	2.71	56.04	4.01	6.90	2.00
VOC [g/h]	64.28	52.57	1.96	0.86	84.42	141.20	71.99	3.23	66.75	4.77	8.22	2.39

**Other Modes**

g_Walk,mi, Effective Walk Time [s]	8.0		7.0		-5.8		8.0	
M_corner, Corner Circulation Area [ft <sup>2</sup> /ped]	0.00		0.00		0.00		0.00	
M_CW, Crosswalk Circulation Area [ft <sup>2</sup> /ped]	0.00		0.00		0.00		0.00	
d_p, Pedestrian Delay [s]	27.63		28.53		41.22		27.63	
I_p,int, Pedestrian LOS Score for Intersectio	2.668		2.834		2.708		2.149	
Crosswalk LOS	B		C		B		B	
s_b, Saturation Flow Rate of the bicycle lane	2000		2000		2000		2000	
c_b, Capacity of the bicycle lane [bicycles/h]	1421		1421		853		853	
d_b, Bicycle Delay [s]	2.94		2.94		11.57		11.57	
I_b,int, Bicycle LOS Score for Intersection	2.101		2.466		2.502		1.692	
Bicycle LOS	B		B		B		A	

**Sequence**

Ring 1	1	2	3	4	-	-	-	-	-	-	-	-	-	-	-
Ring 2	5	6	7	8	-	-	-	-	-	-	-	-	-	-	-
Ring 3	-	-	-	-	-	-	-	-	-	-	-	-	-	-	-
Ring 4	-	-	-	-	-	-	-	-	-	-	-	-	-	-	-



**Intersection Level Of Service Report**  
**Intersection 7: Fallon Road & Positano Parkway**

Control Type:	Signalized	Delay (sec / veh):	31.7
Analysis Method:	HCM 7th Edition	Level Of Service:	C
Analysis Period:	15 minutes	Volume to Capacity (v/c):	0.859

**Intersection Setup**

Name	Fallon Road		Fallon Road		Positano Parkway	
Approach	Northbound		Southbound		Westbound	
Lane Configuration	↑↑↑↔		↔↑↑↑		↔↔↔	
Turning Movement	Thru	Right	Left	Thru	Left	Right
Lane Width [ft]	12.00	12.00	12.00	12.00	12.00	12.00
No. of Lanes in Entry Pocket	0	1	1	0	1	1
Entry Pocket Length [ft]	100.00	225.00	325.00	100.00	375.00	425.00
No. of Lanes in Exit Pocket	0	0	0	0	0	0
Exit Pocket Length [ft]	0.00	0.00	0.00	0.00	0.00	0.00
Speed [mph]	30.00		30.00		30.00	
Grade [%]	0.00		0.00		0.00	
Curb Present	No		No		No	
Crosswalk	Yes		Yes		Yes	



**Volumes**

Name	Fallon Road		Fallon Road		Positano Parkway	
Base Volume Input [veh/h]	372	185	350	644	562	505
Base Volume Adjustment Factor	1.0000	1.0000	1.0000	1.0000	1.0000	1.0000
Heavy Vehicles Percentage [%]	2.90	0.50	0.30	0.60	0.00	0.70
Proportion of CAVs [%]	0.00					
Growth Factor	1.0000	1.0000	1.0000	1.0000	1.0000	1.0000
In-Process Volume [veh/h]	0	0	0	0	0	0
Site-Generated Trips [veh/h]	0	0	0	0	0	0
Diverted Trips [veh/h]	0	0	0	0	0	0
Pass-by Trips [veh/h]	0	0	0	0	0	0
Existing Site Adjustment Volume [veh/h]	0	0	0	0	0	0
Other Volume [veh/h]	0	0	0	0	0	0
Right Turn on Red Volume [veh/h]	0	0	0	0	0	0
Total Hourly Volume [veh/h]	372	185	350	644	562	505
Peak Hour Factor	0.8400	0.8400	0.8400	0.8400	0.8400	0.8400
Other Adjustment Factor	1.0000	1.0000	1.0000	1.0000	1.0000	1.0000
Total 15-Minute Volume [veh/h]	111	55	104	192	167	150
Total Analysis Volume [veh/h]	443	220	417	767	669	601
Presence of On-Street Parking	No	No	No	No	No	No
On-Street Parking Maneuver Rate [/h]	0	0	0	0	0	0
Local Bus Stopping Rate [/h]	0	0	0	0	0	0
v_do, Outbound Pedestrian Volume crossing	0		2		2	
v_di, Inbound Pedestrian Volume crossing m	0		2		2	
v_co, Outbound Pedestrian Volume crossing	0		0		1	
v_ci, Inbound Pedestrian Volume crossing mi	1		0		0	
v_ab, Corner Pedestrian Volume [ped/h]	0		0		0	
Bicycle Volume [bicycles/h]	0		0		2	



**Intersection Settings**

Located in CBD	No
Signal Coordination Group	-
Cycle Length [s]	90
Active Pattern	Free Running (No Pattern)
Coordination Type	<i>Free Running</i>
Actuation Type	<i>Fully actuated</i>
Offset [s]	0.0
Offset Reference	Lead Green - Beginning of First Green
Permissive Mode	SingleBand
Lost time [s]	9.00

**Phasing & Timing (Basic)**

Control Type	Permissive	Permissive	Protected	Permissive	Permissive	Permissive
Signal Group	4	0	7	8	6	0
Auxiliary Signal Groups						
Maximum Green [s]	30	0	20	30	24	0
Amber [s]	4.3	0.0	3.5	4.3	4.0	0.0
All red [s]	1.0	0.0	1.0	1.0	1.0	0.0
Walk [s]	0	0	0	4	4	0
Pedestrian Clearance [s]	0	0	0	20	34	0
Delayed Vehicle Green [s]	0.0	0.0	0.0	0.0	0.0	0.0
Rest In Walk	No			No	No	
I1, Start-Up Lost Time [s]	2.0	0.0	2.0	2.0	2.0	0.0
I2, Clearance Lost Time [s]	2.0	0.0	2.0	2.0	2.0	0.0
Detector Location [ft]	0.0	0.0	0.0	0.0	0.0	0.0
Detector Length [ft]	20.0	0.0	20.0	20.0	20.0	0.0
I, Upstream Filtering Factor	1.00	1.00	1.00	1.00	1.00	1.00

**Phasing & Timing: Free Running (No Pattern)**

Split [s]	14	0	9	14	9	0
Lead / Lag	-	-	Lead	-	Lead	-
Minimum Green [s]	10	0	5	10	5	0
Vehicle Extension [s]	3.0	0.0	3.0	3.0	3.0	0.0
Minimum Recall	Yes		No	Yes	No	
Maximum Recall	No		No	No	No	
Pedestrian Recall	No		No	No	No	

**Exclusive Pedestrian Phase**

Pedestrian Signal Group	0
Pedestrian Walk [s]	0
Pedestrian Clearance [s]	0



**Lane Group Calculations**

Lane Group	C	R	L	C	L	R
C, Cycle Length [s]	70	70	70	70	70	70
L, Total Lost Time per Cycle [s]	4.00	4.00	4.00	4.00	4.00	4.00
l1_p, Permitted Start-Up Lost Time [s]	0.00	0.00	0.00	0.00	0.00	0.00
l2, Clearance Lost Time [s]	2.00	2.00	2.00	2.00	2.00	2.00
g_i, Effective Green Time [s]	14	14	18	37	25	25
g / C, Green / Cycle	0.21	0.21	0.26	0.53	0.36	0.36
(v / s)_i Volume / Saturation Flow Rate	0.09	0.14	0.23	0.15	0.19	0.38
s, saturation flow rate [veh/h]	5057	1606	1805	5151	3514	1580
c, Capacity [veh/h]	1045	332	477	2720	1256	565
d1, Uniform Delay [s]	24.12	25.50	24.61	9.15	17.83	22.26
k, delay calibration	0.11	0.11	0.29	0.11	0.11	0.50
l, Upstream Filtering Factor	1.00	1.00	1.00	1.00	1.00	1.00
d2, Incremental Delay [s]	0.27	2.27	12.50	0.06	0.35	56.12
d3, Initial Queue Delay [s]	0.00	0.00	0.00	0.00	0.00	0.00
Rp, platoon ratio	1.00	1.00	1.00	1.00	1.00	1.00
PF, progression factor	1.00	1.00	1.00	1.00	1.00	1.00

**Lane Group Results**

X, volume / capacity	0.42	0.66	0.87	0.28	0.53	1.06
d, Delay for Lane Group [s/veh]	24.40	27.77	37.11	9.21	18.18	78.37
Lane Group LOS	C	C	D	A	B	F
Critical Lane Group	No	Yes	Yes	No	No	Yes
50th-Percentile Queue Length [veh/ln]	2.05	3.40	7.83	1.90	4.01	17.13
50th-Percentile Queue Length [ft/ln]	51.26	84.92	195.81	47.53	100.24	428.14
95th-Percentile Queue Length [veh/ln]	3.69	6.11	12.42	3.42	7.22	24.91
95th-Percentile Queue Length [ft/ln]	92.28	152.85	310.55	85.56	180.43	622.67

**Movement, Approach, & Intersection Results**

d_M, Delay for Movement [s/veh]	24.40	27.77	37.11	9.21	18.18	78.37
Movement LOS	C	C	D	A	B	F
d_A, Approach Delay [s/veh]	25.52		19.03		46.66	
Approach LOS	C		B		D	
d_I, Intersection Delay [s/veh]	31.67					
Intersection LOS	C					
Intersection V/C	0.859					

**Emissions**

Vehicle Miles Traveled [mph]	111.42	55.33	36.59	67.29	80.22	72.07
Stops [stops/h]	317.35	175.22	404.05	294.26	413.69	883.46
Fuel consumption [US gal/h]	8.54	4.49	6.89	5.83	8.06	17.43
CO [g/h]	596.91	313.79	481.45	407.72	563.59	1218.51
NOx [g/h]	116.14	61.05	93.67	79.33	109.65	237.08
VOC [g/h]	138.34	72.72	111.58	94.49	130.62	282.40

**Other Modes**

g_Walk,mi, Effective Walk Time [s]	8.0		8.0		8.7	
M_corner, Corner Circulation Area [ft <sup>2</sup> /ped]	0.00		0.00		0.00	
M_CW, Crosswalk Circulation Area [ft <sup>2</sup> /ped]	0.00		0.00		0.00	
d_p, Pedestrian Delay [s]	27.35		27.35		26.74	
I_p,int, Pedestrian LOS Score for Intersectio	2.876		2.894		2.585	
Crosswalk LOS	C		C		B	
s_b, Saturation Flow Rate of the bicycle lane	2000		2000		2000	
c_b, Capacity of the bicycle lane [bicycles/h]	860		860		688	
d_b, Bicycle Delay [s]	11.34		11.34		15.03	
I_b,int, Bicycle LOS Score for Intersection	1.924		2.211		1.560	
Bicycle LOS	A		B		A	

**Sequence**

Ring 1	-	-	-	8	-	-	-	-	-	-	-	-	-	-	-	-
Ring 2	-	6	7	4	-	-	-	-	-	-	-	-	-	-	-	-
Ring 3	-	-	-	-	-	-	-	-	-	-	-	-	-	-	-	-
Ring 4	-	-	-	-	-	-	-	-	-	-	-	-	-	-	-	-

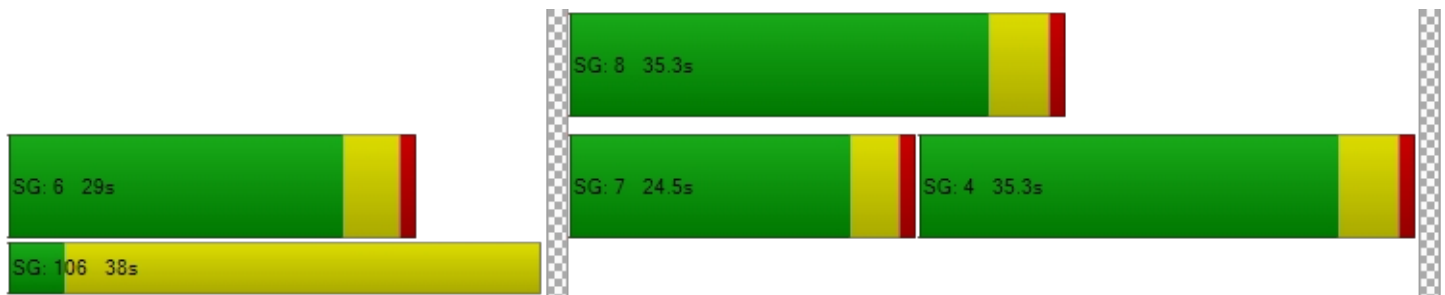



**Intersection Level Of Service Report**  
**Intersection 8: Fallon Road & Central Parkway**

Control Type:	Signalized	Delay (sec / veh):	34.1
Analysis Method:	HCM 7th Edition	Level Of Service:	C
Analysis Period:	15 minutes	Volume to Capacity (v/c):	0.605

**Intersection Setup**

Name	Fallon Road			Fallon Road			Central Parkway			Central Parkway		
Approach	Northbound			Southbound			Eastbound			Westbound		
Lane Configuration												
Turning Movement	Left	Thru	Right	Left	Thru	Right	Left	Thru	Right	Left	Thru	Right
Lane Width [ft]	12.00	12.00	12.00	12.00	12.00	12.00	12.00	12.00	12.00	12.00	12.00	12.00
No. of Lanes in Entry Pocket	2	0	1	1	0	1	2	0	2	2	0	1
Entry Pocket Length [ft]	300.00	100.00	255.00	295.00	100.00	245.00	350.00	100.00	230.00	250.00	100.00	250.00
No. of Lanes in Exit Pocket	0	0	1	0	0	2	0	0	0	0	0	0
Exit Pocket Length [ft]	0.00	0.00	250.00	0.00	0.00	500.00	0.00	0.00	0.00	0.00	0.00	0.00
Speed [mph]	40.00			30.00			25.00			30.00		
Grade [%]	0.00			0.00			0.00			0.00		
Curb Present	Yes			Yes			Yes			Yes		
Crosswalk	Yes			Yes			Yes			Yes		



**Volumes**

Name	Fallon Road			Fallon Road			Central Parkway			Central Parkway		
Base Volume Input [veh/h]	55	538	152	73	978	59	52	176	91	358	185	94
Base Volume Adjustment Factor	1.0000	1.0000	1.0000	1.0000	1.0000	1.0000	1.0000	1.0000	1.0000	1.0000	1.0000	1.0000
Heavy Vehicles Percentage [%]	6.00	1.20	0.70	0.00	0.40	1.80	0.00	0.60	3.30	0.00	0.60	1.20
Proportion of CAVs [%]	0.00											
Growth Factor	1.0000	1.0000	1.0000	1.0000	1.0000	1.0000	1.0000	1.0000	1.0000	1.0000	1.0000	1.0000
In-Process Volume [veh/h]	0	0	0	0	0	0	0	0	0	0	0	0
Site-Generated Trips [veh/h]	0	0	0	0	0	0	0	0	0	0	0	0
Diverted Trips [veh/h]	0	0	0	0	0	0	0	0	0	0	0	0
Pass-by Trips [veh/h]	0	0	0	0	0	0	0	0	0	0	0	0
Existing Site Adjustment Volume [veh/h]	0	0	0	0	0	0	0	0	0	0	0	0
Other Volume [veh/h]	0	0	0	0	0	0	0	0	0	0	0	0
Right Turn on Red Volume [veh/h]	0	0	0	0	0	0	0	0	0	0	0	0
Total Hourly Volume [veh/h]	55	538	152	73	978	59	52	176	91	358	185	94
Peak Hour Factor	0.7500	0.7500	0.7500	0.7500	0.7500	0.7500	0.7500	0.7500	0.7500	0.7500	0.7500	0.7500
Other Adjustment Factor	1.0000	1.0000	1.0000	1.0000	1.0000	1.0000	1.0000	1.0000	1.0000	1.0000	1.0000	1.0000
Total 15-Minute Volume [veh/h]	18	179	51	24	326	20	17	59	30	119	62	31
Total Analysis Volume [veh/h]	73	717	203	97	1304	79	69	235	121	477	247	125
Presence of On-Street Parking	No		No	No		No	No		No	No		No
On-Street Parking Maneuver Rate [/h]	0	0	0	0	0	0	0	0	0	0	0	0
Local Bus Stopping Rate [/h]	0	0	0	0	0	0	0	0	0	0	0	0
v_do, Outbound Pedestrian Volume crossing	1			2			2			1		
v_di, Inbound Pedestrian Volume crossing m	1			2			2			1		
v_co, Outbound Pedestrian Volume crossing	44			4			43			4		
v_ci, Inbound Pedestrian Volume crossing mi	43			4			44			4		
v_ab, Corner Pedestrian Volume [ped/h]	0			0			0			0		
Bicycle Volume [bicycles/h]	1			0			6			0		



**Intersection Settings**

Located in CBD	No
Signal Coordination Group	-
Cycle Length [s]	90
Active Pattern	Free Running (No Pattern)
Coordination Type	<i>Free Running</i>
Actuation Type	<i>Fully actuated</i>
Offset [s]	0.0
Offset Reference	Lead Green - Beginning of First Green
Permissive Mode	SingleBand
Lost time [s]	12.00

**Phasing & Timing (Basic)**

Control Type	Protecte	Permiss	Permiss	Protecte	Permiss	Permiss	Protecte	Permiss	Permiss	Protecte	Permiss	Permiss
Signal Group	3	8	0	7	4	0	5	2	0	1	6	0
Auxiliary Signal Groups												
Maximum Green [s]	20	30	0	20	30	0	20	30	0	20	30	0
Amber [s]	3.5	4.3	0.0	3.0	4.3	0.0	3.0	4.0	0.0	3.0	4.0	0.0
All red [s]	1.0	1.0	0.0	1.0	1.0	0.0	1.0	1.0	0.0	1.0	1.0	0.0
Walk [s]	0	4	0	0	4	0	0	4	0	0	4	0
Pedestrian Clearance [s]	0	28	0	0	34	0	0	42	0	0	41	0
Delayed Vehicle Green [s]	0.0	0.0	0.0	0.0	0.0	0.0	0.0	0.0	0.0	0.0	0.0	0.0
Rest In Walk		No			No			No			No	
I1, Start-Up Lost Time [s]	2.0	2.0	0.0	2.0	2.0	0.0	2.0	2.0	0.0	2.0	2.0	0.0
I2, Clearance Lost Time [s]	2.0	2.0	0.0	2.0	2.0	0.0	2.0	2.0	0.0	2.0	2.0	0.0
Detector Location [ft]	0.0	0.0	0.0	0.0	0.0	0.0	0.0	0.0	0.0	0.0	0.0	0.0
Detector Length [ft]	20.0	20.0	0.0	20.0	20.0	0.0	20.0	20.0	0.0	20.0	20.0	0.0
I, Upstream Filtering Factor	1.00	1.00	1.00	1.00	1.00	1.00	1.00	1.00	1.00	1.00	1.00	1.00

**Phasing & Timing: Free Running (No Pattern)**

Split [s]	0	0	0	0	0	0	0	0	0	0	0	0
Lead / Lag	Lead	-	-	Lead	-	-	Lead	-	-	Lead	-	-
Minimum Green [s]	10	12	0	10	12	0	10	12	0	10	12	0
Vehicle Extension [s]	2.0	4.0	0.0	2.0	4.0	0.0	2.0	4.0	0.0	2.0	4.0	0.0
Minimum Recall	No	Yes		No	Yes		No	No		No	No	
Maximum Recall	No	No		No	No		No	No		No	No	
Pedestrian Recall	No	No		No	No		No	No		No	No	

**Exclusive Pedestrian Phase**

Pedestrian Signal Group	0
Pedestrian Walk [s]	0
Pedestrian Clearance [s]	0



**Lane Group Calculations**

Lane Group	L	C	R	L	C	R	L	C	R	L	C	R
C, Cycle Length [s]	104	104	104	104	104	104	104	104	104	104	104	104
L, Total Lost Time per Cycle [s]	4.00	4.00	4.00	4.00	4.00	4.00	4.00	4.00	4.00	4.00	4.00	4.00
l1_p, Permitted Start-Up Lost Time [s]	0.00	0.00	0.00	0.00	0.00	0.00	0.00	0.00	0.00	0.00	0.00	0.00
l2, Clearance Lost Time [s]	2.00	2.00	2.00	2.00	2.00	2.00	2.00	2.00	2.00	2.00	2.00	2.00
g_i, Effective Green Time [s]	9	31	31	9	31	31	9	31	31	16	39	39
g / C, Green / Cycle	0.09	0.30	0.30	0.09	0.30	0.30	0.08	0.30	0.30	0.16	0.37	0.37
(v / s)_i Volume / Saturation Flow Rate	0.02	0.14	0.13	0.05	0.25	0.05	0.02	0.12	0.05	0.14	0.13	0.08
s, saturation flow rate [veh/h]	3348	5127	1567	1810	5159	1586	3514	1891	2501	3514	1891	1589
c, Capacity [veh/h]	303	1531	468	165	1545	475	296	564	747	553	703	591
d1, Uniform Delay [s]	43.91	29.70	29.24	45.30	34.10	26.81	44.42	29.18	26.72	42.65	23.58	22.24
k, delay calibration	0.04	0.15	0.15	0.04	0.15	0.15	0.04	0.15	0.15	0.04	0.15	0.15
l, Upstream Filtering Factor	1.00	1.00	1.00	1.00	1.00	1.00	1.00	1.00	1.00	1.00	1.00	1.00
d2, Incremental Delay [s]	0.15	0.32	0.90	1.23	1.89	0.23	0.15	0.70	0.14	1.59	0.43	0.25
d3, Initial Queue Delay [s]	0.00	0.00	0.00	0.00	0.00	0.00	0.00	0.00	0.00	0.00	0.00	0.00
Rp, platoon ratio	1.00	1.00	1.00	1.00	1.00	1.00	1.00	1.00	1.00	1.00	1.00	1.00
PF, progression factor	1.00	1.00	1.00	1.00	1.00	1.00	1.00	1.00	1.00	1.00	1.00	1.00

**Lane Group Results**

X, volume / capacity	0.24	0.47	0.43	0.59	0.84	0.17	0.23	0.42	0.16	0.86	0.35	0.21
d, Delay for Lane Group [s/veh]	44.06	30.02	30.15	46.53	35.99	27.04	44.56	29.88	26.86	44.25	24.01	22.49
Lane Group LOS	D	C	C	D	D	C	D	C	C	D	C	C
Critical Lane Group	Yes	No	No	No	Yes	No	No	Yes	No	Yes	No	No
50th-Percentile Queue Length [veh/ln]	0.86	4.73	4.04	2.44	10.33	1.47	0.84	4.81	1.12	6.03	4.40	2.10
50th-Percentile Queue Length [ft/ln]	21.49	118.26	100.90	61.10	258.16	36.69	21.03	120.36	28.10	150.67	110.04	52.56
95th-Percentile Queue Length [veh/ln]	1.55	8.30	7.26	4.40	15.60	2.64	1.51	8.41	2.02	10.05	7.84	3.78
95th-Percentile Queue Length [ft/ln]	38.69	207.44	181.62	109.99	389.91	66.05	37.85	210.32	50.57	251.32	196.06	94.60



**Movement, Approach, & Intersection Results**

d_M, Delay for Movement [s/veh]	44.06	30.02	30.15	46.53	35.99	27.04	44.56	29.88	26.86	44.25	24.01	22.49
Movement LOS	D	C	C	D	D	C	D	C	C	D	C	C
d_A, Approach Delay [s/veh]	31.08			36.20			31.40			35.16		
Approach LOS	C			D			C			D		
d_I, Intersection Delay [s/veh]	34.06											
Intersection LOS	C											
Intersection V/C	0.605											

**Emissions**

Vehicle Miles Traveled [mph]	19.33	189.84	53.75	24.40	327.97	19.87	6.03	20.54	10.58	108.44	56.15	28.42
Stops [stops/h]	59.70	492.73	140.13	84.86	1075.58	50.96	58.41	167.16	78.04	418.50	152.83	72.99
Fuel consumption [US gal/h]	1.93	16.02	4.55	2.39	28.99	1.53	1.12	2.99	1.44	11.07	4.36	2.15
CO [g/h]	135.14	1119.82	317.85	167.17	2026.60	107.24	78.35	209.26	100.39	773.85	304.95	149.95
NOx [g/h]	26.29	217.88	61.84	32.52	394.30	20.87	15.24	40.71	19.53	150.56	59.33	29.18
VOC [g/h]	31.32	259.53	73.66	38.74	469.68	24.85	18.16	48.50	23.27	179.35	70.68	34.75

**Other Modes**

g_Walk,mi, Effective Walk Time [s]	8.0			8.0			8.0			8.0		
M_corner, Corner Circulation Area [ft <sup>2</sup> /ped]	0.00			0.00			0.00			0.00		
M_CW, Crosswalk Circulation Area [ft <sup>2</sup> /ped]	0.00			0.00			0.00			0.00		
d_p, Pedestrian Delay [s]	44.15			44.15			44.15			44.15		
I_p,int, Pedestrian LOS Score for Intersectio	3.277			3.209			2.699			2.579		
Crosswalk LOS	C			C			B			B		
s_b, Saturation Flow Rate of the bicycle lane	2000			2000			2000			2000		
c_b, Capacity of the bicycle lane [bicycles/h]	579			579			579			579		
d_b, Bicycle Delay [s]	26.20			26.18			26.26			26.18		
I_b,int, Bicycle LOS Score for Intersection	2.106			2.374			2.261			2.960		
Bicycle LOS	B			B			B			C		

**Sequence**

Ring 1	1	2	3	4	-	-	-	-	-	-	-	-	-	-	-
Ring 2	5	6	7	8	-	-	-	-	-	-	-	-	-	-	-
Ring 3	-	-	-	-	-	-	-	-	-	-	-	-	-	-	-
Ring 4	-	-	-	-	-	-	-	-	-	-	-	-	-	-	-

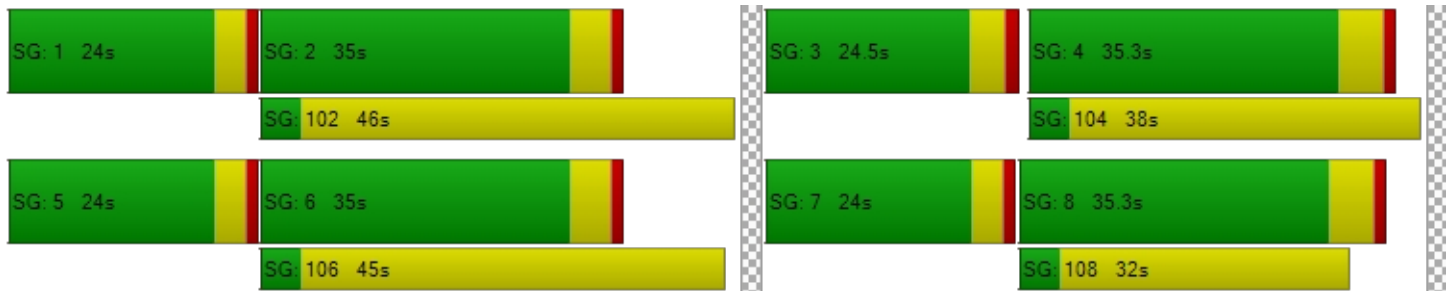

**Intersection Level Of Service Report**  
**Intersection 9: Fallon Road & Dublin Boulevard**

Control Type:	Signalized	Delay (sec / veh):	23.4
Analysis Method:	HCM 7th Edition	Level Of Service:	C
Analysis Period:	15 minutes	Volume to Capacity (v/c):	0.567

**Intersection Setup**

Name	Fallon Road			Fallon Road			Dublin Boulevard			Dublin Boulevard		
Approach	Northbound			Southbound			Eastbound			Westbound		
Lane Configuration	T T T			T T T			T T T T			T T		
Turning Movement	Left	Thru	Right	Left	Thru	Right	Left	Thru	Right	Left	Thru	Right
Lane Width [ft]	12.00	12.00	12.00	12.00	12.00	12.00	12.00	12.00	12.00	12.00	12.00	12.00
No. of Lanes in Entry Pocket	2	0	0	1	0	1	1	0	1	0	0	0
Entry Pocket Length [ft]	430.00	100.00	100.00	140.00	100.00	225.00	400.00	100.00	400.00	100.00	100.00	100.00
No. of Lanes in Exit Pocket	0	0	0	0	0	0	0	0	1	0	0	0
Exit Pocket Length [ft]	0.00	0.00	0.00	0.00	0.00	0.00	0.00	0.00	500.00	0.00	0.00	0.00
Speed [mph]	45.00			45.00			45.00			45.00		
Grade [%]	0.00			0.00			0.00			0.00		
Curb Present	Yes			Yes			Yes			Yes		
Crosswalk	No			No			Yes			Yes		



**Volumes**

Name	Fallon Road			Fallon Road			Dublin Boulevard			Dublin Boulevard		
Base Volume Input [veh/h]	253	511	29	2	1207	227	136	20	199	8	2	25
Base Volume Adjustment Factor	1.0000	1.0000	1.0000	1.0000	1.0000	1.0000	1.0000	1.0000	1.0000	1.0000	1.0000	1.0000
Heavy Vehicles Percentage [%]	3.50	1.20	4.00	1.00	0.50	0.00	0.70	4.00	3.50	1.00	1.00	1.00
Proportion of CAVs [%]	0.00											
Growth Factor	1.0000	1.0000	1.0000	1.0000	1.0000	1.0000	1.0000	1.0000	1.0000	1.0000	1.0000	1.0000
In-Process Volume [veh/h]	0	0	0	0	0	0	0	0	0	0	0	0
Site-Generated Trips [veh/h]	0	0	0	0	0	0	0	0	0	0	0	0
Diverted Trips [veh/h]	0	0	0	0	0	0	0	0	0	0	0	0
Pass-by Trips [veh/h]	0	0	0	0	0	0	0	0	0	0	0	0
Existing Site Adjustment Volume [veh/h]	0	0	0	0	0	0	0	0	0	0	0	0
Other Volume [veh/h]	0	0	0	0	0	0	0	0	0	0	0	0
Right Turn on Red Volume [veh/h]	0	0	0	0	0	0	0	0	0	0	0	0
Total Hourly Volume [veh/h]	253	511	29	2	1207	227	136	20	199	8	2	25
Peak Hour Factor	0.9200	0.9200	0.9400	0.9400	0.9200	0.9200	0.9200	0.9400	0.9200	0.9400	0.9400	0.9400
Other Adjustment Factor	1.0000	1.0000	1.0000	1.0000	1.0000	1.0000	1.0000	1.0000	1.0000	1.0000	1.0000	1.0000
Total 15-Minute Volume [veh/h]	69	139	8	1	328	62	37	5	54	2	1	7
Total Analysis Volume [veh/h]	275	555	31	2	1312	247	148	21	216	9	2	27
Presence of On-Street Parking	No		No	No		No	No		No	No		No
On-Street Parking Maneuver Rate [/h]	0	0	0	0	0	0	0	0	0	0	0	0
Local Bus Stopping Rate [/h]	0	0	0	0	0	0	0	0	0	0	0	0
v_do, Outbound Pedestrian Volume crossing	0			0			0			0		
v_di, Inbound Pedestrian Volume crossing m	0			0			0			0		
v_co, Outbound Pedestrian Volume crossing	2			4			4			3		
v_ci, Inbound Pedestrian Volume crossing mi	3			4			4			2		
v_ab, Corner Pedestrian Volume [ped/h]	0			0			0			0		
Bicycle Volume [bicycles/h]	0			0			0			0		



**Intersection Settings**

Located in CBD	No
Signal Coordination Group	-
Cycle Length [s]	140
Active Pattern	Pattern 1
Coordination Type	Time of Day Pattern Isolated
Actuation Type	Fully actuated
Offset [s]	0.0
Offset Reference	Lead Green - Beginning of First Green
Permissive Mode	SingleBand
Lost time [s]	12.00

**Phasing & Timing (Basic)**

Control Type	Protecte	Permiss	Permiss	Protecte	Permiss	Permiss	Protecte	Permiss	Overlap	Protecte	Permiss	Permiss
Signal Group	3	8	0	7	4	0	5	2	2	1	6	0
Auxiliary Signal Groups									2,3			
Maximum Green [s]	30	30	0	12	30	0	30	30	30	12	12	0
Amber [s]	4.3	4.7	0.0	4.3	4.7	0.0	4.3	4.3	4.3	3.0	4.8	0.0
All red [s]	1.0	1.0	0.0	1.0	1.0	0.0	1.0	1.0	1.0	1.0	1.0	0.0
Walk [s]	0	0	0	0	4	0	0	0	0	0	0	0
Pedestrian Clearance [s]	0	0	0	0	41	0	0	0	0	0	0	0
Delayed Vehicle Green [s]	0.0	0.0	0.0	0.0	0.0	0.0	0.0	0.0	0.0	0.0	0.0	0.0
Rest In Walk		No			No			No			No	
I1, Start-Up Lost Time [s]	2.0	2.0	0.0	2.0	2.0	0.0	2.0	2.0	2.0	2.0	2.0	0.0
I2, Clearance Lost Time [s]	2.0	2.0	0.0	2.0	2.0	0.0	2.0	2.0	2.0	2.0	2.0	0.0
Detector Location [ft]	0.0	0.0	0.0	0.0	0.0	0.0	0.0	0.0	0.0	0.0	0.0	0.0
Detector Length [ft]	20.0	20.0	0.0	20.0	20.0	0.0	0.0	0.0	0.0	20.0	20.0	0.0
I, Upstream Filtering Factor	1.00	1.00	1.00	1.00	1.00	1.00	1.00	1.00	1.00	1.00	1.00	1.00

**Phasing & Timing: Pattern 1**

Split [s]	35	65	0	20	50	0	35	35	35	20	20	0
Lead / Lag	Lead	-	-	Lead	-	-	Lead	-	-	Lead	-	-
Minimum Green [s]	10	12	0	10	12	0	10	12	12	10	10	0
Vehicle Extension [s]	2.0	4.0	0.0	2.0	4.0	0.0	2.0	4.0	4.0	2.0	2.0	0.0
Minimum Recall	No	Yes		No	Yes		No	No	No	No	No	
Maximum Recall	No	No		No	No		No	No	No	No	No	
Pedestrian Recall	No	No		No	No		No	No	No	No	No	

**Exclusive Pedestrian Phase**

Pedestrian Signal Group	0
Pedestrian Walk [s]	0
Pedestrian Clearance [s]	0





**Lane Group Calculations**

Lane Group	L	C	C	L	C	R	L	C	R	L	C
C, Cycle Length [s]	140	140	140	140	140	140	140	140	140	140	140
L, Total Lost Time per Cycle [s]	4.00	4.00	4.00	4.00	4.00	4.00	4.00	4.00	4.00	4.00	4.00
l1_p, Permitted Start-Up Lost Time [s]	0.00	0.00	0.00	0.00	0.00	0.00	0.00	0.00	0.00	0.00	0.00
l2, Clearance Lost Time [s]	2.00	2.00	2.00	2.00	2.00	2.00	2.00	2.00	0.00	2.00	2.00
g_i, Effective Green Time [s]	16	102	102	2	89	89	11	17	36	3	9
g / C, Green / Cycle	0.11	0.73	0.73	0.01	0.63	0.63	0.08	0.12	0.26	0.02	0.06
(v / s)_i Volume / Saturation Flow Rate	0.08	0.16	0.16	0.00	0.36	0.15	0.04	0.01	0.08	0.01	0.02
s, saturation flow rate [veh/h]	3417	1882	1847	1795	3603	1609	3495	1840	2780	1795	1619
c, Capacity [veh/h]	380	1372	1346	27	2279	1017	282	222	699	38	99
d1, Uniform Delay [s]	60.11	6.10	6.10	68.01	14.87	11.16	61.75	54.72	42.53	67.39	62.81
k, delay calibration	0.04	0.50	0.50	0.04	0.50	0.50	0.04	0.15	0.15	0.04	0.04
l, Upstream Filtering Factor	1.00	1.00	1.00	1.00	1.00	1.00	1.00	1.00	1.00	1.00	1.00
d2, Incremental Delay [s]	0.98	0.36	0.37	0.44	1.07	0.57	0.56	0.26	0.35	1.17	0.60
d3, Initial Queue Delay [s]	0.00	0.00	0.00	0.00	0.00	0.00	0.00	0.00	0.00	0.00	0.00
Rp, platoon ratio	1.00	1.00	1.00	1.00	1.00	1.00	1.00	1.00	1.00	1.00	1.00
PF, progression factor	1.00	1.00	1.00	1.00	1.00	1.00	1.00	1.00	1.00	1.00	1.00

**Lane Group Results**

X, volume / capacity	0.72	0.22	0.22	0.08	0.58	0.24	0.52	0.09	0.31	0.24	0.29
d, Delay for Lane Group [s/veh]	61.09	6.46	6.47	68.45	15.94	11.73	62.31	54.98	42.88	68.56	63.41
Lane Group LOS	E	A	A	E	B	B	E	D	D	E	E
Critical Lane Group	Yes	No	No	No	Yes	No	No	No	Yes	Yes	No
50th-Percentile Queue Length [veh/ln]	4.69	2.58	2.54	0.07	11.40	3.29	2.51	0.67	3.03	0.32	0.99
50th-Percentile Queue Length [ft/ln]	117.16	64.52	63.41	1.82	284.95	82.16	62.72	16.67	75.66	8.11	24.73
95th-Percentile Queue Length [veh/ln]	8.24	4.65	4.57	0.13	16.93	5.92	4.52	1.20	5.45	0.58	1.78
95th-Percentile Queue Length [ft/ln]	205.91	116.14	114.15	3.28	423.37	147.89	112.90	30.00	136.18	14.60	44.52

**Movement, Approach, & Intersection Results**

d_M, Delay for Movement [s/veh]	61.09	6.47	6.47	68.45	15.94	11.73	62.31	54.98	42.88	68.56	63.41	63.41
Movement LOS	E	A	A	E	B	B	E	D	D	E	E	E
d_A, Approach Delay [s/veh]	23.91			15.34			51.01			64.63		
Approach LOS	C			B			D			E		
d_I, Intersection Delay [s/veh]	23.42											
Intersection LOS	C											
Intersection V/C	0.567											

**Emissions**

Vehicle Miles Traveled [mph]	36.93	39.71	38.99	0.53	347.38	65.40	178.07	25.27	259.88	2.02	6.51
Stops [stops/h]	241.04	66.37	65.23	1.87	586.25	84.52	129.05	17.14	155.65	8.34	25.44
Fuel consumption [US gal/h]	7.68	2.58	2.53	0.07	23.45	3.88	9.58	1.31	12.73	0.30	0.91
CO [g/h]	536.93	180.02	176.83	4.84	1639.30	271.37	669.97	91.86	889.69	20.87	63.86
NOx [g/h]	104.47	35.03	34.40	0.94	318.95	52.80	130.35	17.87	173.10	4.06	12.42
VOC [g/h]	124.44	41.72	40.98	1.12	379.92	62.89	155.27	21.29	206.19	4.84	14.80

**Other Modes**

g_Walk,mi, Effective Walk Time [s]	0.0			0.0			8.0			59.3		
M_corner, Corner Circulation Area [ft <sup>2</sup> /ped]	0.00			0.00			0.00			0.00		
M_CW, Crosswalk Circulation Area [ft <sup>2</sup> /ped]	0.00			0.00			361.90			0.00		
d_p, Pedestrian Delay [s]	0.00			0.00			62.22			23.25		
I_p,int, Pedestrian LOS Score for Intersectio	0.000			0.000			2.915			2.148		
Crosswalk LOS	F			F			C			B		
s_b, Saturation Flow Rate of the bicycle lane	2000			2000			2000			2000		
c_b, Capacity of the bicycle lane [bicycles/h]	847			633			424			203		
d_b, Bicycle Delay [s]	23.25			32.70			43.44			56.51		
I_b,int, Bicycle LOS Score for Intersection	2.270			2.847			2.195			1.622		
Bicycle LOS	B			C			B			A		

**Sequence**

Ring 1	1	2	3	4	-	-	-	-	-	-	-	-	-	-	-
Ring 2	5	6	7	8	-	-	-	-	-	-	-	-	-	-	-
Ring 3	-	-	-	-	-	-	-	-	-	-	-	-	-	-	-
Ring 4	-	-	-	-	-	-	-	-	-	-	-	-	-	-	-



**Intersection Level Of Service Report**  
**Intersection 10: Fallon Road & Fallon Gateway**

Control Type:	Signalized	Delay (sec / veh):	13.5
Analysis Method:	HCM 7th Edition	Level Of Service:	B
Analysis Period:	15 minutes	Volume to Capacity (v/c):	0.543

**Intersection Setup**

Name	Fallon Road		Fallon Road		Fallon Gateway	
Approach	Northbound		Southbound		Eastbound	
Lane Configuration	⇐⇐		⇐		⇐⇐⇐⇐	
Turning Movement	Left	Thru	Thru	Right	Left	Right
Lane Width [ft]	12.00	12.00	12.00	12.00	12.00	12.00
No. of Lanes in Entry Pocket	1	0	0	0	1	1
Entry Pocket Length [ft]	275.00	100.00	100.00	100.00	210.00	210.00
No. of Lanes in Exit Pocket	0	0	0	0	0	0
Exit Pocket Length [ft]	0.00	0.00	0.00	0.00	0.00	0.00
Speed [mph]	45.00		40.00		25.00	
Grade [%]	0.00		0.00		0.00	
Curb Present	Yes		Yes		Yes	
Crosswalk	No		No		Yes	



**Volumes**

Name	Fallon Road		Fallon Road		Fallon Gateway	
Base Volume Input [veh/h]	182	723	1229	42	20	94
Base Volume Adjustment Factor	1.0000	1.0000	1.0000	1.0000	1.0000	1.0000
Heavy Vehicles Percentage [%]	1.70	4.10	1.00	0.00	0.00	4.30
Proportion of CAVs [%]	0.00					
Growth Factor	1.0000	1.0000	1.0000	1.0000	1.0000	1.0000
In-Process Volume [veh/h]	0	0	0	0	0	0
Site-Generated Trips [veh/h]	0	0	0	0	0	0
Diverted Trips [veh/h]	0	0	0	0	0	0
Pass-by Trips [veh/h]	0	0	0	0	0	0
Existing Site Adjustment Volume [veh/h]	0	0	0	0	0	0
Other Volume [veh/h]	0	0	0	0	0	0
Right Turn on Red Volume [veh/h]	0	0	0	0	0	0
Total Hourly Volume [veh/h]	182	723	1229	42	20	94
Peak Hour Factor	0.9000	0.9000	0.9000	0.9000	0.9000	0.9000
Other Adjustment Factor	1.0000	1.0000	1.0000	1.0000	1.0000	1.0000
Total 15-Minute Volume [veh/h]	51	201	341	12	6	26
Total Analysis Volume [veh/h]	202	803	1366	47	22	104
Presence of On-Street Parking	No	No	No	No	No	No
On-Street Parking Maneuver Rate [/h]	0	0	0	0	0	0
Local Bus Stopping Rate [/h]	0	0	0	0	0	0
v_do, Outbound Pedestrian Volume crossing	0		0		0	
v_di, Inbound Pedestrian Volume crossing m	0		0		0	
v_co, Outbound Pedestrian Volume crossing	0		0		0	
v_ci, Inbound Pedestrian Volume crossing mi	0		0		0	
v_ab, Corner Pedestrian Volume [ped/h]	0		0		0	
Bicycle Volume [bicycles/h]	0		0		0	



**Intersection Settings**

Located in CBD	No
Signal Coordination Group	-
Cycle Length [s]	105
Active Pattern	Pattern 1
Coordination Type	Time of Day Pattern Isolated
Actuation Type	Fully actuated
Offset [s]	0.0
Offset Reference	Lead Green - Beginning of First Green
Permissive Mode	SingleBand
Lost time [s]	9.00

**Phasing & Timing (Basic)**

Control Type	Protected	Permissive	Permissive	Permissive	Permissive	Overlap
Signal Group	3	8	4	0	2	2
Auxiliary Signal Groups						2,3
Maximum Green [s]	20	40	40	0	30	30
Amber [s]	3.5	4.7	4.7	0.0	3.5	3.5
All red [s]	1.0	1.0	1.0	0.0	1.0	1.0
Walk [s]	0	0	4	0	0	0
Pedestrian Clearance [s]	0	0	28	0	0	0
Delayed Vehicle Green [s]	0.0	0.0	0.0	0.0	0.0	0.0
Rest In Walk		No	No		No	
I1, Start-Up Lost Time [s]	2.0	2.0	2.0	0.0	2.0	2.0
I2, Clearance Lost Time [s]	2.5	3.7	3.7	0.0	2.5	2.5
Detector Location [ft]	0.0	0.0	0.0	0.0	0.0	0.0
Detector Length [ft]	20.0	20.0	0.0	0.0	20.0	20.0
I, Upstream Filtering Factor	1.00	1.00	1.00	1.00	1.00	1.00

**Phasing & Timing: Pattern 1**

Split [s]	25	70	45	0	35	35
Lead / Lag	Lead	-	-	-	Lead	-
Minimum Green [s]	10	10	10	0	10	10
Vehicle Extension [s]	2.0	5.0	5.0	0.0	2.0	2.0
Minimum Recall	No	Yes	Yes		No	No
Maximum Recall	No	No	No		No	No
Pedestrian Recall	No	No	No		No	No

**Exclusive Pedestrian Phase**

Pedestrian Signal Group	0
Pedestrian Walk [s]	0
Pedestrian Clearance [s]	0



**Lane Group Calculations**

Lane Group	L	C	C	C	L	R
C, Cycle Length [s]	66	66	66	66	66	66
L, Total Lost Time per Cycle [s]	4.50	5.70	5.70	5.70	4.50	4.50
l1_p, Permitted Start-Up Lost Time [s]	0.00	0.00	0.00	0.00	0.00	0.00
l2, Clearance Lost Time [s]	2.50	3.70	3.70	3.70	2.50	0.00
g_i, Effective Green Time [s]	10	46	32	32	9	23
g / C, Green / Cycle	0.15	0.71	0.49	0.49	0.14	0.35
(v / s)_i Volume / Saturation Flow Rate	0.06	0.23	0.37	0.38	0.01	0.04
s, saturation flow rate [veh/h]	3467	3500	1885	1863	3514	2761
c, Capacity [veh/h]	515	2476	925	914	483	979
d1, Uniform Delay [s]	25.33	3.65	13.66	13.75	24.62	14.25
k, delay calibration	0.04	0.23	0.27	0.27	0.04	0.04
l, Upstream Filtering Factor	1.00	1.00	1.00	1.00	1.00	1.00
d2, Incremental Delay [s]	0.18	0.16	3.25	3.49	0.01	0.02
d3, Initial Queue Delay [s]	0.00	0.00	0.00	0.00	0.00	0.00
Rp, platoon ratio	1.00	1.00	1.00	1.00	1.00	1.00
PF, progression factor	1.00	1.00	1.00	1.00	1.00	1.00

**Lane Group Results**

X, volume / capacity	0.39	0.32	0.76	0.77	0.05	0.11
d, Delay for Lane Group [s/veh]	25.51	3.81	16.91	17.25	24.64	14.26
Lane Group LOS	C	A	B	B	C	B
Critical Lane Group	Yes	No	No	Yes	No	Yes
50th-Percentile Queue Length [veh/ln]	1.30	0.98	7.57	7.67	0.15	0.50
50th-Percentile Queue Length [ft/ln]	32.42	24.51	189.36	191.85	3.64	12.38
95th-Percentile Queue Length [veh/ln]	2.33	1.76	12.09	12.22	0.26	0.89
95th-Percentile Queue Length [ft/ln]	58.35	44.11	302.20	305.43	6.56	22.28

**Movement, Approach, & Intersection Results**

d_M, Delay for Movement [s/veh]	25.51	3.81	17.07	17.25	24.64	14.26
Movement LOS	C	A	B	B	C	B
d_A, Approach Delay [s/veh]	8.17		17.08		16.08	
Approach LOS	A		B		B	
d_I, Intersection Delay [s/veh]	13.51					
Intersection LOS	B					
Intersection V/C	0.543					

**Emissions**

Vehicle Miles Traveled [mph]	30.73	122.17	94.89	94.89	1.35	6.38
Stops [stops/h]	142.13	107.44	415.12	420.59	15.98	54.28
Fuel consumption [US gal/h]	3.87	6.15	9.91	10.01	0.23	0.80
CO [g/h]	270.46	429.69	692.58	699.74	16.24	55.71
NOx [g/h]	52.62	83.60	134.75	136.14	3.16	10.84
VOC [g/h]	62.68	99.58	160.51	162.17	3.76	12.91

**Other Modes**

g_Walk,mi, Effective Walk Time [s]	0.0		0.0		8.0	
M_corner, Corner Circulation Area [ft <sup>2</sup> /ped]	0.00		0.00		0.00	
M_CW, Crosswalk Circulation Area [ft <sup>2</sup> /ped]	0.00		0.00		0.00	
d_p, Pedestrian Delay [s]	0.00		0.00		25.33	
I_p,int, Pedestrian LOS Score for Intersectio	0.000		0.000		2.491	
Crosswalk LOS	F		F		B	
s_b, Saturation Flow Rate of the bicycle lane	2000		2000		2000	
c_b, Capacity of the bicycle lane [bicycles/h]	1958		1197		929	
d_b, Bicycle Delay [s]	0.01		5.30		9.42	
I_b,int, Bicycle LOS Score for Intersection	2.389		2.725		1.560	
Bicycle LOS	B		B		A	

**Sequence**

Ring 1	-	2	3	4	-	-	-	-	-	-	-	-	-	-	-	-
Ring 2	-	-	-	8	-	-	-	-	-	-	-	-	-	-	-	-
Ring 3	-	-	-	-	-	-	-	-	-	-	-	-	-	-	-	-
Ring 4	-	-	-	-	-	-	-	-	-	-	-	-	-	-	-	-

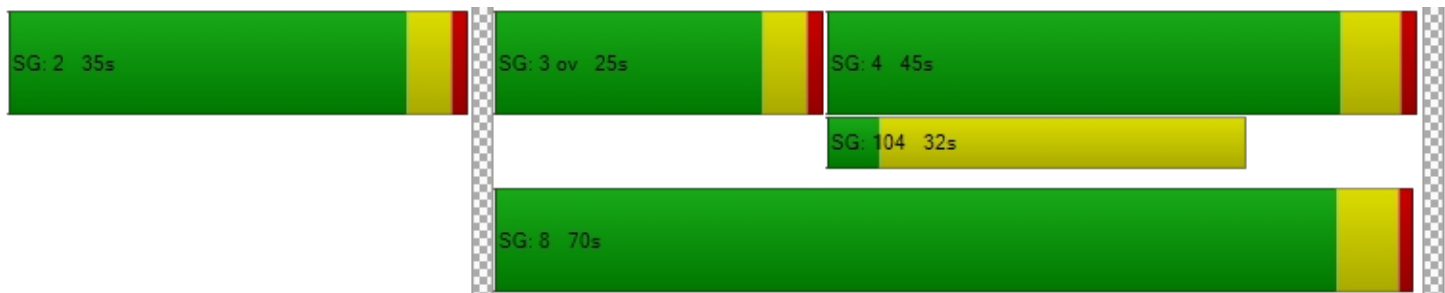

**Intersection Level Of Service Report**  
**Intersection 11: Fallon Road & I-580 WB Ramps**

Control Type:	Signalized	Delay (sec / veh):	9.0
Analysis Method:	HCM 7th Edition	Level Of Service:	A
Analysis Period:	15 minutes	Volume to Capacity (v/c):	0.777

**Intersection Setup**

Name	Fallon Road			Fallon Road			I-580 WB On-Ramp			I-580 WB Off-Ramp		
Approach	Northbound			Southbound			Eastbound			Westbound		
Lane Configuration	↑			↑↑↑						↑↑↑		
Turning Movement	Left	Thru	Right	Left	Thru	Right	Left	Thru	Right	Left	Thru	Right
Lane Width [ft]	12.00	12.00	12.00	12.00	12.00	12.00	12.00	12.00	12.00	12.00	12.00	12.00
No. of Lanes in Entry Pocket	0	0	0	0	0	1	0	0	0	1	0	1
Entry Pocket Length [ft]	100.00	100.00	100.00	100.00	100.00	225.00	100.00	100.00	100.00	170.00	100.00	130.00
No. of Lanes in Exit Pocket	0	0	1	0	0	0	0	0	1	0	0	0
Exit Pocket Length [ft]	0.00	0.00	400.00	0.00	0.00	0.00	0.00	0.00	400.00	0.00	0.00	0.00
Speed [mph]	45.00			40.00			30.00			35.00		
Grade [%]	0.00			0.00			0.00			0.00		
Curb Present	No			No						No		
Crosswalk	No			No			No			No		





**Volumes**

Name	Fallon Road			Fallon Road			I-580 WB On-Ramp			I-580 WB Off-Ramp		
Base Volume Input [veh/h]	0	542	0	0	721	721	0	0	0	227	7	477
Base Volume Adjustment Factor	1.0000	1.0000	1.0000	1.0000	1.0000	1.0000	1.0000	1.0000	1.0000	1.0000	1.0000	1.0000
Heavy Vehicles Percentage [%]	2.00	0.60	2.00	2.00	1.90	0.40	2.00	2.00	2.00	4.20	0.00	4.00
Proportion of CAVs [%]	0.00											
Growth Factor	1.0000	1.0000	1.0000	1.0000	1.0000	1.0000	1.0000	1.0000	1.0000	1.0000	1.0000	1.0000
In-Process Volume [veh/h]	0	0	0	0	0	0	0	0	0	0	0	0
Site-Generated Trips [veh/h]	0	0	0	0	0	0	0	0	0	0	0	0
Diverted Trips [veh/h]	0	0	0	0	0	0	0	0	0	0	0	0
Pass-by Trips [veh/h]	0	0	0	0	0	0	0	0	0	0	0	0
Existing Site Adjustment Volume [veh/h]	0	0	0	0	0	0	0	0	0	0	0	0
Other Volume [veh/h]	0	0	0	0	0	0	0	0	0	0	0	0
Right Turn on Red Volume [veh/h]	0	0	0	0	0	0	0	0	0	0	0	0
Total Hourly Volume [veh/h]	0	542	0	0	721	721	0	0	0	227	7	477
Peak Hour Factor	1.0000	0.9500	1.0000	1.0000	0.9500	0.9500	1.0000	1.0000	1.0000	0.9500	0.9500	0.9500
Other Adjustment Factor	1.0000	1.0000	1.0000	1.0000	1.0000	1.0000	1.0000	1.0000	1.0000	1.0000	1.0000	1.0000
Total 15-Minute Volume [veh/h]	0	143	0	0	190	190	0	0	0	60	2	126
Total Analysis Volume [veh/h]	0	571	0	0	759	759	0	0	0	239	7	502
Presence of On-Street Parking	No		No	No		No				No		No
On-Street Parking Maneuver Rate [/h]	0	0	0	0	0	0	0	0	0	0	0	0
Local Bus Stopping Rate [/h]	0	0	0	0	0	0	0	0	0	0	0	0
v_do, Outbound Pedestrian Volume crossing	0			0			0			0		
v_di, Inbound Pedestrian Volume crossing m	0			0			0			0		
v_co, Outbound Pedestrian Volume crossing	0			0			0			0		
v_ci, Inbound Pedestrian Volume crossing mi	0			0			0			0		
v_ab, Corner Pedestrian Volume [ped/h]	0			0			0			0		
Bicycle Volume [bicycles/h]	0			0			0			0		



**Intersection Settings**

Located in CBD	No
Signal Coordination Group	-
Cycle Length [s]	90
Active Pattern	Free Running (No Pattern)
Coordination Type	<i>Free Running</i>
Actuation Type	<i>Fully actuated</i>
Offset [s]	0.0
Offset Reference	Lead Green - Beginning of First Green
Permissive Mode	SingleBand
Lost time [s]	9.00

**Phasing & Timing (Basic)**

Control Type	Permiss	Permiss	Permiss	Permiss	Permiss	Permiss	Permiss	Permiss	Permiss	Permiss	Permiss	Overlap
Signal Group	0	2	0	0	6	0	0	0	0	0	8	1
Auxiliary Signal Groups												1,8
Maximum Green [s]	0	35	0	0	35	0	0	0	0	0	20	15
Amber [s]	0.0	4.8	0.0	0.0	4.8	0.0	0.0	0.0	0.0	0.0	3.7	3.7
All red [s]	0.0	0.5	0.0	0.0	0.5	0.0	0.0	0.0	0.0	0.0	0.5	0.5
Walk [s]	0	0	0	0	0	0	0	0	0	0	0	0
Pedestrian Clearance [s]	0	0	0	0	0	0	0	0	0	0	0	0
Delayed Vehicle Green [s]	0.0	0.0	0.0	0.0	0.0	0.0	0.0	0.0	0.0	0.0	0.0	0.0
Rest In Walk		No			No						No	
I1, Start-Up Lost Time [s]	0.0	2.0	0.0	0.0	2.0	0.0	0.0	0.0	0.0	0.0	2.0	2.0
I2, Clearance Lost Time [s]	0.0	3.3	0.0	0.0	3.3	0.0	0.0	0.0	0.0	0.0	2.2	2.2
Detector Location [ft]	0.0	0.0	0.0	0.0	0.0	0.0	0.0	0.0	0.0	0.0	0.0	0.0
Detector Length [ft]	0.0	20.0	0.0	0.0	20.0	0.0	0.0	0.0	0.0	0.0	20.0	20.0
I, Upstream Filtering Factor	1.00	1.00	1.00	1.00	1.00	1.00	1.00	1.00	1.00	1.00	1.00	1.00

**Phasing & Timing: Free Running (No Pattern)**

Split [s]	0	0	0	0	0	0	0	0	0	0	0	0
Lead / Lag	-	-	-	-	-	-	-	-	-	-	-	-
Minimum Green [s]	0	10	0	0	10	0	0	0	0	0	5	4
Vehicle Extension [s]	0.0	0.0	0.0	0.0	0.0	0.0	0.0	0.0	0.0	0.0	0.0	0.0
Minimum Recall		Yes			Yes						No	No
Maximum Recall		No			No						No	No
Pedestrian Recall		No			No						No	No

**Exclusive Pedestrian Phase**

Pedestrian Signal Group	0
Pedestrian Walk [s]	0
Pedestrian Clearance [s]	0



**Lane Group Calculations**

Lane Group	C	C	R		L	C	R
C, Cycle Length [s]	43	43	43		43	43	43
L, Total Lost Time per Cycle [s]	5.30	5.30	5.30		4.20	4.20	4.20
l1_p, Permitted Start-Up Lost Time [s]	0.00	0.00	0.00		0.00	0.00	0.00
l2, Clearance Lost Time [s]	3.30	3.30	3.30		2.20	2.20	0.00
g_i, Effective Green Time [s]	14	26	26		7	7	19
g / C, Green / Cycle	0.34	0.61	0.61		0.17	0.17	0.44
(v / s)_i Volume / Saturation Flow Rate	0.30	0.21	0.47		0.07	0.07	0.18
s, saturation flow rate [veh/h]	1891	3563	1610		1749	1814	2768
c, Capacity [veh/h]	636	2159	976		301	312	1223
d1, Uniform Delay [s]	13.50	4.22	6.28		15.76	15.76	8.15
k, delay calibration	0.04	0.04	0.06		0.04	0.04	0.04
l, Upstream Filtering Factor	1.00	1.00	1.00		1.00	1.00	1.00
d2, Incremental Delay [s]	1.91	0.04	0.83		0.32	0.31	0.08
d3, Initial Queue Delay [s]	0.00	0.00	0.00		0.00	0.00	0.00
Rp, platoon ratio	1.00	1.00	1.00		1.00	1.00	1.00
PF, progression factor	1.00	1.00	1.00		1.00	1.00	1.00

**Lane Group Results**

X, volume / capacity	0.90	0.35	0.78		0.40	0.40	0.41
d, Delay for Lane Group [s/veh]	15.41	4.26	7.11		16.08	16.07	8.23
Lane Group LOS	B	A	A		B	B	A
Critical Lane Group	No	No	Yes		No	No	Yes
50th-Percentile Queue Length [veh/ln]	3.86	0.66	2.14		0.90	0.93	1.09
50th-Percentile Queue Length [ft/ln]	96.52	16.39	53.61		22.43	23.21	27.24
95th-Percentile Queue Length [veh/ln]	6.95	1.18	3.86		1.61	1.67	1.96
95th-Percentile Queue Length [ft/ln]	173.73	29.50	96.50		40.37	41.78	49.04

**Movement, Approach, & Intersection Results**

d_M, Delay for Movement [s/veh]	0.00	15.41	0.00	0.00	4.26	7.11	0.00	0.00	0.00	16.07	16.07	8.23
Movement LOS		B			A	A				B	B	A
d_A, Approach Delay [s/veh]	15.41		5.68			0.00			10.81			
Approach LOS	B		A			A			B			
d_I, Intersection Delay [s/veh]	8.99											
Intersection LOS	A											
Intersection V/C	0.777											

**Emissions**

Vehicle Miles Traveled [mph]	59.51	115.48	115.48	17.53	18.16	72.83
Stops [stops/h]	325.72	110.62	180.93	75.68	78.34	183.88
Fuel consumption [US gal/h]	7.88	5.88	7.01	1.63	1.69	5.00
CO [g/h]	550.88	411.06	490.18	114.11	118.19	349.47
NOx [g/h]	107.18	79.98	95.37	22.20	22.99	67.99
VOC [g/h]	127.67	95.27	113.60	26.45	27.39	80.99

**Other Modes**

g_Walk,mi, Effective Walk Time [s]	0.0	0.0	0.0	0.0
M_corner, Corner Circulation Area [ft <sup>2</sup> /ped]	0.00	0.00	0.00	0.00
M_CW, Crosswalk Circulation Area [ft <sup>2</sup> /ped]	0.00	0.00	0.00	0.00
d_p, Pedestrian Delay [s]	0.00	0.00	0.00	0.00
I_p,int, Pedestrian LOS Score for Intersectio	0.000	0.000	0.000	0.000
Crosswalk LOS	F	F	F	F
s_b, Saturation Flow Rate of the bicycle lane	2000	2000	2000	2000
c_b, Capacity of the bicycle lane [bicycles/h]	1641	1641	0	937
d_b, Bicycle Delay [s]	0.69	0.69	21.33	6.02
I_b,int, Bicycle LOS Score for Intersection	2.502	2.812	4.132	2.794
Bicycle LOS	B	C	D	C

**Sequence**

Ring 1	1	2	-	-	-	-	-	-	-	-	-	-	-	-	-
Ring 2	-	6	-	8	-	-	-	-	-	-	-	-	-	-	-
Ring 3	-	-	-	-	-	-	-	-	-	-	-	-	-	-	-
Ring 4	-	-	-	-	-	-	-	-	-	-	-	-	-	-	-



**Intersection Level Of Service Report**  
**Intersection 12: El Charro Road & I-580 EB Ramps**

Control Type:	Signalized	Delay (sec / veh):	6.8
Analysis Method:	HCM 7th Edition	Level Of Service:	A
Analysis Period:	15 minutes	Volume to Capacity (v/c):	0.442

**Intersection Setup**

Name	El Charro Road			Fallon Road			I-580 EB Off-Ramp			I-580 EB On-Ramp		
Approach	Northbound			Southbound			Eastbound			Westbound		
Lane Configuration	↑↑			↑↑			↵↵↵↵					
Turning Movement	Left	Thru	Right	Left	Thru	Right	Left	Thru	Right	Left	Thru	Right
Lane Width [ft]	12.00	12.00	12.00	12.00	12.00	12.00	12.00	12.00	12.00	12.00	12.00	12.00
No. of Lanes in Entry Pocket	0	0	0	1	0	0	1	0	1	0	0	0
Entry Pocket Length [ft]	100.00	100.00	100.00	135.00	100.00	100.00	350.00	100.00	350.00	100.00	100.00	100.00
No. of Lanes in Exit Pocket	0	0	0	0	0	1	0	0	0	0	0	0
Exit Pocket Length [ft]	0.00	0.00	0.00	0.00	0.00	100.00	0.00	0.00	0.00	0.00	0.00	0.00
Speed [mph]	30.00			40.00			35.00			30.00		
Grade [%]	0.00			0.00			0.00			0.00		
Curb Present	No			No			No					
Crosswalk	No			No			No			Yes		



**Volumes**

Name	El Charro Road			Fallon Road			I-580 EB Off-Ramp			I-580 EB On-Ramp		
Base Volume Input [veh/h]	0	506	0	0	505	0	333	0	282	0	0	0
Base Volume Adjustment Factor	1.0000	1.0000	1.0000	1.0000	1.0000	1.0000	1.0000	1.0000	1.0000	1.0000	1.0000	1.0000
Heavy Vehicles Percentage [%]	2.00	10.40	2.00	2.00	2.70	2.00	0.90	2.00	10.60	2.00	2.00	2.00
Proportion of CAVs [%]	0.00											
Growth Factor	1.0000	1.0000	1.0000	1.0000	1.0000	1.0000	1.0000	1.0000	1.0000	1.0000	1.0000	1.0000
In-Process Volume [veh/h]	0	0	0	0	0	0	0	0	0	0	0	0
Site-Generated Trips [veh/h]	0	0	0	0	0	0	0	0	0	0	0	0
Diverted Trips [veh/h]	0	0	0	0	0	0	0	0	0	0	0	0
Pass-by Trips [veh/h]	0	0	0	0	0	0	0	0	0	0	0	0
Existing Site Adjustment Volume [veh/h]	0	0	0	0	0	0	0	0	0	0	0	0
Other Volume [veh/h]	0	0	0	0	0	0	0	0	0	0	0	0
Right Turn on Red Volume [veh/h]	0	0	0	0	0	0	0	0	0	0	0	0
Total Hourly Volume [veh/h]	0	506	0	0	505	0	333	0	282	0	0	0
Peak Hour Factor	1.0000	0.9300	1.0000	1.0000	0.9300	1.0000	0.9300	1.0000	0.9300	1.0000	1.0000	1.0000
Other Adjustment Factor	1.0000	1.0000	1.0000	1.0000	1.0000	1.0000	1.0000	1.0000	1.0000	1.0000	1.0000	1.0000
Total 15-Minute Volume [veh/h]	0	136	0	0	136	0	90	0	76	0	0	0
Total Analysis Volume [veh/h]	0	544	0	0	543	0	358	0	303	0	0	0
Presence of On-Street Parking	No		No	No		No	No		No			
On-Street Parking Maneuver Rate [/h]	0	0	0	0	0	0	0	0	0	0	0	0
Local Bus Stopping Rate [/h]	0	0	0	0	0	0	0	0	0	0	0	0
v_do, Outbound Pedestrian Volume crossing	0			0			0			0		
v_di, Inbound Pedestrian Volume crossing m	0			0			0			0		
v_co, Outbound Pedestrian Volume crossing	0			0			0			0		
v_ci, Inbound Pedestrian Volume crossing mi	0			0			0			0		
v_ab, Corner Pedestrian Volume [ped/h]	0			0			0			0		
Bicycle Volume [bicycles/h]	0			0			0			0		



**Intersection Settings**

Located in CBD	No
Signal Coordination Group	-
Cycle Length [s]	90
Active Pattern	Free Running (No Pattern)
Coordination Type	<i>Free Running</i>
Actuation Type	<i>Fully actuated</i>
Offset [s]	0.0
Offset Reference	Lead Green - Beginning of First Green
Permissive Mode	SingleBand
Lost time [s]	9.00

**Phasing & Timing (Basic)**

Control Type	Permiss	Permiss	Permiss	Permiss	Permiss	Permiss	Permiss	Permiss	Permiss	Permiss	Permiss	Permiss
Signal Group	0	2	0	0	6	0	4	0	0	0	0	0
Auxiliary Signal Groups												
Maximum Green [s]	0	40	0	0	40	0	26	0	0	0	0	0
Amber [s]	0.0	4.8	0.0	0.0	4.8	0.0	3.7	0.0	0.0	0.0	0.0	0.0
All red [s]	0.0	1.0	0.0	0.0	1.0	0.0	0.5	0.0	0.0	0.0	0.0	0.0
Walk [s]	0	0	0	0	0	0	0	0	0	0	0	0
Pedestrian Clearance [s]	0	0	0	0	0	0	0	0	0	0	0	0
Delayed Vehicle Green [s]	0.0	0.0	0.0	0.0	0.0	0.0	0.0	0.0	0.0	0.0	0.0	0.0
Rest In Walk		No			No		No					
I1, Start-Up Lost Time [s]	0.0	2.0	0.0	0.0	2.0	0.0	2.0	0.0	0.0	0.0	0.0	0.0
I2, Clearance Lost Time [s]	0.0	3.3	0.0	0.0	3.3	0.0	2.7	0.0	0.0	0.0	0.0	0.0
Detector Location [ft]	0.0	0.0	0.0	0.0	0.0	0.0	0.0	0.0	0.0	0.0	0.0	0.0
Detector Length [ft]	0.0	20.0	0.0	0.0	20.0	0.0	20.0	0.0	0.0	0.0	0.0	0.0
I, Upstream Filtering Factor	1.00	1.00	1.00	1.00	1.00	1.00	1.00	1.00	1.00	1.00	1.00	1.00

**Phasing & Timing: Free Running (No Pattern)**

Split [s]	0	0	0	0	0	0	0	0	0	0	0	0
Lead / Lag	-	-	-	-	-	-	Lead	-	-	-	-	-
Minimum Green [s]	0	10	0	0	10	0	4	0	0	0	0	0
Vehicle Extension [s]	0.0	0.0	0.0	0.0	0.0	0.0	0.0	0.0	0.0	0.0	0.0	0.0
Minimum Recall		Yes			Yes		No					
Maximum Recall		No			No		No					
Pedestrian Recall		No			No		No					

**Exclusive Pedestrian Phase**

Pedestrian Signal Group	0
Pedestrian Walk [s]	0
Pedestrian Clearance [s]	0



**Lane Group Calculations**

Lane Group	C	C	L	R	
C, Cycle Length [s]	25	25	25	25	
L, Total Lost Time per Cycle [s]	5.30	5.30	4.70	4.70	
l1_p, Permitted Start-Up Lost Time [s]	0.00	0.00	0.00	0.00	
l2, Clearance Lost Time [s]	3.30	3.30	2.70	2.70	
g_i, Effective Green Time [s]	10	10	4	4	
g / C, Green / Cycle	0.42	0.42	0.17	0.17	
(v / s)_i Volume / Saturation Flow Rate	0.16	0.15	0.10	0.12	
s, saturation flow rate [veh/h]	3320	3540	3489	2619	
c, Capacity [veh/h]	1396	1489	604	454	
d1, Uniform Delay [s]	4.94	4.88	9.37	9.51	
k, delay calibration	0.04	0.04	0.04	0.04	
l, Upstream Filtering Factor	1.00	1.00	1.00	1.00	
d2, Incremental Delay [s]	0.07	0.06	0.35	0.64	
d3, Initial Queue Delay [s]	0.00	0.00	0.00	0.00	
Rp, platoon ratio	1.00	1.00	1.00	1.00	
PF, progression factor	1.00	1.00	1.00	1.00	

**Lane Group Results**

X, volume / capacity	0.39	0.36	0.59	0.67	
d, Delay for Lane Group [s/veh]	5.01	4.94	9.72	10.15	
Lane Group LOS	A	A	A	B	
Critical Lane Group	Yes	No	No	Yes	
50th-Percentile Queue Length [veh/ln]	0.36	0.21	0.53	0.47	
50th-Percentile Queue Length [ft/ln]	8.95	5.16	13.34	11.83	
95th-Percentile Queue Length [veh/ln]	0.64	0.37	0.96	0.85	
95th-Percentile Queue Length [ft/ln]	16.10	9.28	24.00	21.30	



**Movement, Approach, & Intersection Results**

d_M, Delay for Movement [s/veh]	0.00	5.01	0.00	0.00	4.94	0.00	9.72	0.00	10.15	0.00	0.00	0.00
Movement LOS		A			A		A		B			
d_A, Approach Delay [s/veh]	5.01				4.94		9.91		0.00			
Approach LOS	A				A		A		A			
d_I, Intersection Delay [s/veh]	6.84											
Intersection LOS	A											
Intersection V/C	0.442											

**Emissions**

Vehicle Miles Traveled [mph]	93.65	53.33	41.60	35.21
Stops [stops/h]	105.14	60.59	156.73	139.06
Fuel consumption [US gal/h]	4.99	3.05	3.47	3.01
CO [g/h]	348.85	213.27	242.72	210.65
NOx [g/h]	67.87	41.50	47.23	40.98
VOC [g/h]	80.85	49.43	56.25	48.82

**Other Modes**

g_Walk,mi, Effective Walk Time [s]	0.0	0.0	0.0	-5.8
M_corner, Corner Circulation Area [ft <sup>2</sup> /ped]	0.00	0.00	0.00	0.00
M_CW, Crosswalk Circulation Area [ft <sup>2</sup> /ped]	0.00	0.00	0.00	0.00
d_p, Pedestrian Delay [s]	0.00	0.00	0.00	18.74
I_p,int, Pedestrian LOS Score for Intersectio	0.000	0.000	0.000	1.690
Crosswalk LOS	F	F	F	A
s_b, Saturation Flow Rate of the bicycle lane	2000	2000	2000	2000
c_b, Capacity of the bicycle lane [bicycles/h]	3265	3265	2122	0
d_b, Bicycle Delay [s]	4.90	4.90	0.05	12.25
I_b,int, Bicycle LOS Score for Intersection	2.008	2.008	1.560	4.132
Bicycle LOS	B	B	A	D

**Sequence**

Ring 1	-	2	-	4	-	-	-	-	-	-	-	-	-	-	-
Ring 2	-	6	-	-	-	-	-	-	-	-	-	-	-	-	-
Ring 3	-	-	-	-	-	-	-	-	-	-	-	-	-	-	-
Ring 4	-	-	-	-	-	-	-	-	-	-	-	-	-	-	-



**Intersection Level Of Service Report**  
**Intersection 13: El Charro Road & Jack London Boulevard**

Control Type:	Signalized	Delay (sec / veh):	13.8
Analysis Method:	HCM 7th Edition	Level Of Service:	B
Analysis Period:	15 minutes	Volume to Capacity (v/c):	0.416

**Intersection Setup**

Name	El Charro Road			El Charro Road			Stoneridge Drive			Jack London Boulevard		
Approach	Northbound			Southbound			Eastbound			Westbound		
Lane Configuration	TUT			TUT			TUT			TUT		
Turning Movement	Left	Thru	Right	Left	Thru	Right	Left	Thru	Right	Left	Thru	Right
Lane Width [ft]	12.00	12.00	12.00	12.00	12.00	12.00	12.00	12.00	12.00	12.00	12.00	12.00
No. of Lanes in Entry Pocket	1	0	2	2	0	1	3	0	1	1	0	2
Entry Pocket Length [ft]	125.00	100.00	175.00	650.00	100.00	450.00	450.00	100.00	325.00	400.00	100.00	775.00
No. of Lanes in Exit Pocket	0	0	0	0	0	1	1	0	0	0	0	0
Exit Pocket Length [ft]	0.00	0.00	0.00	0.00	0.00	49.21	450.00	0.00	0.00	0.00	0.00	0.00
Speed [mph]	30.00			30.00			30.00			30.00		
Grade [%]	0.00			0.00			0.00			0.00		
Curb Present	Yes			Yes			Yes			Yes		
Crosswalk	Yes			No			Yes			Yes		



**Volumes**

Name	El Charro Road			El Charro Road			Stoneridge Drive			Jack London Boulevard		
Base Volume Input [veh/h]	25	141	8	241	85	470	194	76	8	31	383	373
Base Volume Adjustment Factor	1.0000	1.0000	1.0000	1.0000	1.0000	1.0000	1.0000	1.0000	1.0000	1.0000	1.0000	1.0000
Heavy Vehicles Percentage [%]	0.00	86.00	33.30	0.40	66.70	0.20	2.30	5.30	0.00	37.50	1.20	1.10
Proportion of CAVs [%]	0.00											
Growth Factor	1.0000	1.0000	1.0000	1.0000	1.0000	1.0000	1.0000	1.0000	1.0000	1.0000	1.0000	1.0000
In-Process Volume [veh/h]	0	0	0	0	0	0	0	0	0	0	0	0
Site-Generated Trips [veh/h]	0	0	0	0	0	0	0	0	0	0	0	0
Diverted Trips [veh/h]	0	0	0	0	0	0	0	0	0	0	0	0
Pass-by Trips [veh/h]	0	0	0	0	0	0	0	0	0	0	0	0
Existing Site Adjustment Volume [veh/h]	0	0	0	0	0	0	0	0	0	0	0	0
Other Volume [veh/h]	0	0	0	0	0	0	0	0	0	0	0	0
Right Turn on Red Volume [veh/h]	0	0	0	0	0	0	0	0	0	0	0	0
Total Hourly Volume [veh/h]	25	141	8	241	85	470	194	76	8	31	383	373
Peak Hour Factor	0.8900	0.8900	0.8900	0.8900	0.8900	0.8900	0.8900	0.8900	0.8900	0.8900	0.8900	0.8900
Other Adjustment Factor	1.0000	1.0000	1.0000	1.0000	1.0000	1.0000	1.0000	1.0000	1.0000	1.0000	1.0000	1.0000
Total 15-Minute Volume [veh/h]	7	40	2	68	24	132	54	21	2	9	108	105
Total Analysis Volume [veh/h]	28	158	9	271	96	528	218	85	9	35	430	419
Presence of On-Street Parking	No		No	No		No	No		No	No		No
On-Street Parking Maneuver Rate [/h]	0	0	0	0	0	0	0	0	0	0	0	0
Local Bus Stopping Rate [/h]	0	0	0	0	0	0	0	0	0	0	0	0
v_do, Outbound Pedestrian Volume crossing	0			0			0			0		
v_di, Inbound Pedestrian Volume crossing m	0			0			0			0		
v_co, Outbound Pedestrian Volume crossing	0			0			0			1		
v_ci, Inbound Pedestrian Volume crossing mi	1			0			0			0		
v_ab, Corner Pedestrian Volume [ped/h]	0			0			0			0		
Bicycle Volume [bicycles/h]	0			0			1			0		



**Intersection Settings**

Located in CBD	No
Signal Coordination Group	-
Cycle Length [s]	90
Active Pattern	Free Running (No Pattern)
Coordination Type	Free Running
Actuation Type	Fully actuated
Offset [s]	0.0
Offset Reference	Lead Green - Beginning of First Green
Permissive Mode	SingleBand
Lost time [s]	12.00

**Phasing & Timing (Basic)**

Control Type	Protecte	Permiss	Permiss	Protecte	Permiss	Unsigna	Protecte	Permiss	Permiss	Protecte	Permiss	Overlap
Signal Group	7	4	0	3	8	0	1	6	0	5	2	2
Auxiliary Signal Groups												2,3
Maximum Green [s]	13	25	0	35	20	0	20	25	0	15	20	20
Amber [s]	3.0	5.0	0.0	3.0	4.3	0.0	3.0	4.3	0.0	3.0	4.3	4.3
All red [s]	1.0	1.0	0.0	1.0	1.0	0.0	1.0	1.0	0.0	1.0	1.0	1.0
Walk [s]	0	5	0	0	5	0	0	5	0	0	0	0
Pedestrian Clearance [s]	0	28	0	0	28	0	0	30	0	0	0	0
Delayed Vehicle Green [s]	0.0	0.0	0.0	0.0	0.0	0.0	0.0	0.0	0.0	0.0	0.0	0.0
Rest In Walk		No			No			No			No	
I1, Start-Up Lost Time [s]	2.0	2.0	0.0	2.0	2.0	0.0	2.0	2.0	0.0	2.0	2.0	2.0
I2, Clearance Lost Time [s]	2.0	2.0	0.0	2.0	2.0	0.0	2.0	2.0	0.0	2.0	2.0	2.0
Detector Location [ft]	0.0	0.0	0.0	0.0	0.0	0.0	0.0	0.0	0.0	0.0	0.0	0.0
Detector Length [ft]	20.0	20.0	0.0	20.0	20.0	0.0	20.0	20.0	0.0	0.0	0.0	0.0
I, Upstream Filtering Factor	1.00	1.00	1.00	1.00	1.00	1.00	1.00	1.00	1.00	1.00	1.00	1.00

**Phasing & Timing: Free Running (No Pattern)**

Split [s]	0	0	0	0	0	0	0	0	0	0	0	0
Lead / Lag	Lead	-	-	Lead	-	-	Lead	-	-	Lead	-	-
Minimum Green [s]	4	5	0	7	5	0	5	4	0	4	7	7
Vehicle Extension [s]	2.0	2.5	0.0	2.5	2.5	0.0	2.0	3.0	0.0	2.0	3.0	3.0
Minimum Recall	No	No		No	No		No	Yes		No	Yes	Yes
Maximum Recall	No	No		No	No		No	No		No	No	No
Pedestrian Recall	No	No		No	No		No	No		No	No	No

**Exclusive Pedestrian Phase**

Pedestrian Signal Group	0
Pedestrian Walk [s]	0
Pedestrian Clearance [s]	0



**Lane Group Calculations**

Lane Group	L	C	C	L	C	L	C	R	L	C	R
C, Cycle Length [s]	47	47	47	47	47	47	47	47	47	47	47
L, Total Lost Time per Cycle [s]	4.00	4.00	4.00	4.00	4.00	4.00	4.00	4.00	4.00	4.00	4.00
l1_p, Permitted Start-Up Lost Time [s]	0.00	0.00	0.00	0.00	0.00	0.00	0.00	0.00	0.00	0.00	0.00
l2, Clearance Lost Time [s]	2.00	2.00	2.00	2.00	2.00	2.00	2.00	2.00	2.00	2.00	0.00
g_i, Effective Green Time [s]	1	8	8	8	15	5	14	14	1	10	22
g / C, Green / Cycle	0.03	0.17	0.17	0.17	0.32	0.10	0.29	0.29	0.03	0.22	0.47
(v / s)_i Volume / Saturation Flow Rate	0.02	0.09	0.10	0.05	0.11	0.04	0.02	0.01	0.03	0.12	0.15
s, saturation flow rate [veh/h]	1810	1160	593	5254	899	5175	3466	1581	1273	3583	2834
c, Capacity [veh/h]	48	198	101	904	284	518	995	454	40	783	1346
d1, Uniform Delay [s]	22.74	17.94	17.98	17.07	12.37	19.97	12.31	12.08	22.77	16.39	7.64
k, delay calibration	0.04	0.08	0.08	0.08	0.08	0.04	0.11	0.11	0.04	0.11	0.11
l, Upstream Filtering Factor	1.00	1.00	1.00	1.00	1.00	1.00	1.00	1.00	1.00	1.00	1.00
d2, Incremental Delay [s]	4.14	1.80	3.66	0.14	0.52	0.20	0.04	0.02	17.91	0.60	0.13
d3, Initial Queue Delay [s]	0.00	0.00	0.00	0.00	0.00	0.00	0.00	0.00	0.00	0.00	0.00
Rp, platoon ratio	1.00	1.00	1.00	1.00	1.00	1.00	1.00	1.00	1.00	1.00	1.00
PF, progression factor	1.00	1.00	1.00	1.00	1.00	1.00	1.00	1.00	1.00	1.00	1.00

**Lane Group Results**

X, volume / capacity	0.58	0.55	0.57	0.30	0.34	0.42	0.09	0.02	0.87	0.55	0.31
d, Delay for Lane Group [s/veh]	26.87	19.74	21.64	17.21	12.88	20.17	12.35	12.09	40.68	17.00	7.77
Lane Group LOS	C	B	C	B	B	C	B	B	D	B	A
Critical Lane Group	No	No	Yes	Yes	No	Yes	No	No	No	Yes	No
50th-Percentile Queue Length [veh/ln]	0.34	0.53	0.61	0.77	0.69	0.68	0.29	0.06	0.55	1.86	1.00
50th-Percentile Queue Length [ft/ln]	8.38	13.32	15.20	19.22	17.34	17.10	7.15	1.51	13.83	46.50	25.12
95th-Percentile Queue Length [veh/ln]	0.60	0.96	1.09	1.38	1.25	1.23	0.51	0.11	1.00	3.35	1.81
95th-Percentile Queue Length [ft/ln]	15.09	23.97	27.36	34.60	31.20	30.78	12.86	2.72	24.89	83.70	45.21



**Movement, Approach, & Intersection Results**

d_M, Delay for Movement [s/veh]	26.87	20.32	21.64	17.21	12.88	0.00	20.17	12.35	12.09	40.68	17.00	7.77
Movement LOS	C	C	C	B	B		C	B	B	D	B	A
d_A, Approach Delay [s/veh]	21.32			7.05			17.80			13.56		
Approach LOS	C			A			B			B		
d_I, Intersection Delay [s/veh]	13.82											
Intersection LOS	B											
Intersection V/C	0.416											

**Emissions**

Vehicle Miles Traveled [mph]	1.78	6.97	3.63	46.65	16.53	23.34	9.10	0.96	6.08	74.70	72.79
Stops [stops/h]	25.63	81.43	46.46	176.33	53.00	156.82	43.70	4.63	42.27	284.33	153.59
Fuel consumption [US gal/h]	0.37	1.18	0.66	3.84	1.22	2.72	0.83	0.09	0.77	6.13	4.51
CO [g/h]	25.72	82.31	46.02	268.70	85.62	190.28	58.00	6.11	54.07	428.75	315.08
NOx [g/h]	5.00	16.02	8.95	52.28	16.66	37.02	11.28	1.19	10.52	83.42	61.30
VOC [g/h]	5.96	19.08	10.67	62.27	19.84	44.10	13.44	1.42	12.53	99.37	73.02

**Other Modes**

g_Walk,mi, Effective Walk Time [s]	9.0		0.0		9.0		9.0
M_corner, Corner Circulation Area [ft <sup>2</sup> /ped]	0.00		0.00		0.00		0.00
M_CW, Crosswalk Circulation Area [ft <sup>2</sup> /ped]	0.00		0.00		0.00		0.00
d_p, Pedestrian Delay [s]	15.41		0.00		15.41		15.41
I_p,int, Pedestrian LOS Score for Intersectio	2.332		0.000		2.900		2.845
Crosswalk LOS	B		F		C		C
s_b, Saturation Flow Rate of the bicycle lane	2000		2000		2000		2000
c_b, Capacity of the bicycle lane [bicycles/h]	1062		849		1062		849
d_b, Bicycle Delay [s]	5.19		7.80		5.19		7.80
I_b,int, Bicycle LOS Score for Intersection	1.667		2.165		1.817		2.289
Bicycle LOS	A		B		A		B

**Sequence**

Ring 1	1	2	3	4	-	-	-	-	-	-	-	-	-	-	-
Ring 2	5	6	7	8	-	-	-	-	-	-	-	-	-	-	-
Ring 3	-	-	-	-	-	-	-	-	-	-	-	-	-	-	-
Ring 4	-	-	-	-	-	-	-	-	-	-	-	-	-	-	-

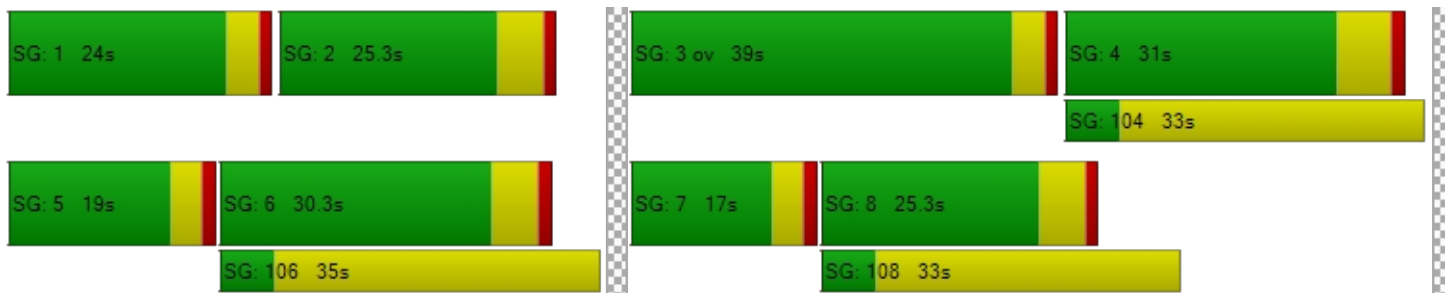

**Intersection Level Of Service Report**  
**Intersection 14: Central Parkway & Sunset View Drive**

Control Type:	Signalized	Delay (sec / veh):	42.5
Analysis Method:	HCM 7th Edition	Level Of Service:	D
Analysis Period:	15 minutes	Volume to Capacity (v/c):	0.856

**Intersection Setup**

Name	Driveway			Sunset View Drive			Central Parkway			Central Parkway		
Approach	Northbound			Southbound			Eastbound			Westbound		
Lane Configuration	↔			↔			↔↔			↔		
Turning Movement	Left	Thru	Right	Left	Thru	Right	Left	Thru	Right	Left	Thru	Right
Lane Width [ft]	12.00	12.00	12.00	12.00	12.00	12.00	12.00	12.00	12.00	12.00	12.00	12.00
No. of Lanes in Entry Pocket	1	0	0	0	0	1	1	0	1	1	0	0
Entry Pocket Length [ft]	250.00	100.00	100.00	100.00	100.00	85.00	225.00	100.00	800.00	150.00	100.00	100.00
No. of Lanes in Exit Pocket	0	0	0	0	0	0	0	0	0	0	0	0
Exit Pocket Length [ft]	0.00	0.00	0.00	0.00	0.00	0.00	0.00	0.00	0.00	0.00	0.00	0.00
Speed [mph]	30.00			30.00			30.00			30.00		
Grade [%]	0.00			0.00			0.00			0.00		
Curb Present	No			No			No			No		
Crosswalk	Yes			Yes			Yes			Yes		



**Volumes**

Name	Driveway			Sunset View Drive			Central Parkway			Central Parkway		
Base Volume Input [veh/h]	151	18	8	17	16	150	40	175	171	17	331	2
Base Volume Adjustment Factor	1.0000	1.0000	1.0000	1.0000	1.0000	1.0000	1.0000	1.0000	1.0000	1.0000	1.0000	1.0000
Heavy Vehicles Percentage [%]	0.70	0.00	0.00	0.00	0.00	2.00	2.50	1.70	0.00	0.00	0.40	0.00
Proportion of CAVs [%]	0.00											
Growth Factor	1.0000	1.0000	1.0000	1.0000	1.0000	1.0000	1.0000	1.0000	1.0000	1.0000	1.0000	1.0000
In-Process Volume [veh/h]	0	0	0	0	0	0	0	0	0	0	0	0
Site-Generated Trips [veh/h]	0	0	0	0	0	0	0	0	0	0	0	0
Diverted Trips [veh/h]	0	0	0	0	0	0	0	0	0	0	0	0
Pass-by Trips [veh/h]	0	0	0	0	0	0	0	0	0	0	0	0
Existing Site Adjustment Volume [veh/h]	0	0	0	0	0	0	0	0	0	0	0	0
Other Volume [veh/h]	0	0	0	0	0	0	0	0	0	0	0	0
Right Turn on Red Volume [veh/h]	0	0	0	0	0	0	0	0	0	0	0	0
Total Hourly Volume [veh/h]	151	18	8	17	16	150	40	175	171	17	331	2
Peak Hour Factor	0.5500	0.5500	0.5500	0.5500	0.5500	0.5500	0.5500	0.5500	0.5500	0.5500	0.5500	0.5500
Other Adjustment Factor	1.0000	1.0000	1.0000	1.0000	1.0000	1.0000	1.0000	1.0000	1.0000	1.0000	1.0000	1.0000
Total 15-Minute Volume [veh/h]	69	8	4	8	7	68	18	80	78	8	150	1
Total Analysis Volume [veh/h]	275	33	15	31	29	273	73	318	311	31	602	4
Presence of On-Street Parking	No		No	No		No	No		No	No		No
On-Street Parking Maneuver Rate [/h]	0	0	0	0	0	0	0	0	0	0	0	0
Local Bus Stopping Rate [/h]	0	0	0	0	0	0	0	0	0	0	0	0
v_do, Outbound Pedestrian Volume crossing	74			14			74			14		
v_di, Inbound Pedestrian Volume crossing m	74			14			74			14		
v_co, Outbound Pedestrian Volume crossing	123			37			37			124		
v_ci, Inbound Pedestrian Volume crossing mi	124			37			37			123		
v_ab, Corner Pedestrian Volume [ped/h]	0			0			0			0		
Bicycle Volume [bicycles/h]	2			0			11			0		





**Intersection Settings**

Located in CBD	No
Signal Coordination Group	-
Cycle Length [s]	90
Active Pattern	Free Running (No Pattern)
Coordination Type	<i>Free Running</i>
Actuation Type	<i>Fully actuated</i>
Offset [s]	0.0
Offset Reference	Lead Green - Beginning of First Green
Permissive Mode	SingleBand
Lost time [s]	12.00

**Phasing & Timing (Basic)**

Control Type	Protecte	Permiss	Permiss	Protecte	Permiss	Permiss	Protecte	Permiss	Permiss	Protecte	Permiss	Permiss
Signal Group	3	8	0	7	4	0	5	2	0	1	6	0
Auxiliary Signal Groups												
Maximum Green [s]	30	30	0	20	20	0	20	25	0	20	25	0
Amber [s]	3.0	3.0	0.0	3.0	3.0	0.0	3.0	3.6	0.0	3.0	3.6	0.0
All red [s]	1.0	1.0	0.0	1.0	1.0	0.0	1.0	1.0	0.0	1.0	1.0	0.0
Walk [s]	0	4	0	0	4	0	0	4	0	0	4	0
Pedestrian Clearance [s]	0	24	0	0	21	0	0	16	0	0	17	0
Delayed Vehicle Green [s]	0.0	0.0	0.0	0.0	0.0	0.0	0.0	0.0	0.0	0.0	0.0	0.0
Rest In Walk		No			No			No			No	
I1, Start-Up Lost Time [s]	2.0	2.0	0.0	2.0	2.0	0.0	2.0	2.0	0.0	2.0	2.0	0.0
I2, Clearance Lost Time [s]	2.0	2.0	0.0	2.0	2.0	0.0	2.0	2.0	0.0	2.0	2.0	0.0
Detector Location [ft]	0.0	0.0	0.0	0.0	0.0	0.0	0.0	0.0	0.0	0.0	0.0	0.0
Detector Length [ft]	20.0	20.0	0.0	20.0	20.0	0.0	20.0	20.0	0.0	20.0	20.0	0.0
I, Upstream Filtering Factor	1.00	1.00	1.00	1.00	1.00	1.00	1.00	1.00	1.00	1.00	1.00	1.00

**Phasing & Timing: Free Running (No Pattern)**

Split [s]	9	14	0	9	14	0	9	14	0	9	14	0
Lead / Lag	Lead	-	-	Lead	-	-	Lead	-	-	Lead	-	-
Minimum Green [s]	5	10	0	5	10	0	5	10	0	5	10	0
Vehicle Extension [s]	2.0	4.0	0.0	2.0	4.0	0.0	2.0	4.0	0.0	2.0	4.0	0.0
Minimum Recall	No	No		No	No		No	Yes		No	Yes	
Maximum Recall	No	No		No	No		No	No		No	No	
Pedestrian Recall	No	No		No	No		No	No		No	No	

**Exclusive Pedestrian Phase**

Pedestrian Signal Group	0
Pedestrian Walk [s]	0
Pedestrian Clearance [s]	0



**Lane Group Calculations**

Lane Group	L	C	L	C	L	C	R	L	C
C, Cycle Length [s]	80	80	80	80	80	80	80	80	80
L, Total Lost Time per Cycle [s]	4.00	4.00	4.00	4.00	4.00	4.00	4.00	4.00	4.00
l1_p, Permitted Start-Up Lost Time [s]	0.00	0.00	0.00	0.00	0.00	0.00	0.00	0.00	0.00
l2, Clearance Lost Time [s]	2.00	2.00	2.00	2.00	2.00	2.00	2.00	2.00	2.00
g_i, Effective Green Time [s]	14	32	3	20	4	27	27	3	26
g / C, Green / Cycle	0.18	0.40	0.03	0.25	0.05	0.34	0.34	0.03	0.32
(v / s)_i Volume / Saturation Flow Rate	0.15	0.03	0.02	0.21	0.04	0.17	0.25	0.02	0.32
s, saturation flow rate [veh/h]	1800	1540	1810	1412	1774	1874	1224	1810	1891
c, Capacity [veh/h]	322	609	58	351	97	639	417	58	602
d1, Uniform Delay [s]	31.97	15.15	38.30	28.85	37.46	21.03	21.63	38.30	27.39
k, delay calibration	0.04	0.15	0.04	0.35	0.04	0.16	0.33	0.04	0.47
l, Upstream Filtering Factor	1.00	1.00	1.00	1.00	1.00	1.00	1.00	1.00	1.00
d2, Incremental Delay [s]	2.52	0.08	2.77	17.17	4.38	0.88	7.84	2.77	37.01
d3, Initial Queue Delay [s]	0.00	0.00	0.00	0.00	0.00	0.00	0.00	0.00	0.00
Rp, platoon ratio	1.00	1.00	1.00	1.00	1.00	1.00	1.00	1.00	1.00
PF, progression factor	1.00	1.00	1.00	1.00	1.00	1.00	1.00	1.00	1.00

**Lane Group Results**

X, volume / capacity	0.85	0.08	0.53	0.86	0.75	0.50	0.75	0.53	1.01
d, Delay for Lane Group [s/veh]	34.49	15.23	41.07	46.02	41.84	21.90	29.46	41.07	64.40
Lane Group LOS	C	B	D	D	D	C	C	D	F
Critical Lane Group	Yes	No	No	Yes	Yes	No	No	No	Yes
50th-Percentile Queue Length [veh/ln]	5.23	0.54	0.63	7.00	1.50	4.67	5.45	0.63	17.06
50th-Percentile Queue Length [ft/ln]	130.86	13.44	15.87	174.92	37.59	116.84	136.31	15.87	426.44
95th-Percentile Queue Length [veh/ln]	8.99	0.97	1.14	11.33	2.71	8.22	9.28	1.14	23.93
95th-Percentile Queue Length [ft/ln]	224.66	24.19	28.56	283.37	67.66	205.47	232.05	28.56	598.20

**Movement, Approach, & Intersection Results**

d_M, Delay for Movement [s/veh]	34.49	15.23	15.23	41.07	46.02	46.02	41.84	21.90	29.46	41.07	64.40	64.40
Movement LOS	C	B	B	D	D	D	D	C	C	D	E	E
d_A, Approach Delay [s/veh]	31.63			45.56			27.33			63.27		
Approach LOS	C			D			C			E		
d_I, Intersection Delay [s/veh]	42.54											
Intersection LOS	D											
Intersection V/C	0.856											

**Emissions**

Vehicle Miles Traveled [mph]	7.49	1.31	1.15	11.23	16.60	72.29	70.70	6.55	128.11
Stops [stops/h]	234.83	24.11	28.47	313.90	67.46	209.67	244.61	28.47	765.25
Fuel consumption [US gal/h]	3.54	0.34	0.46	5.02	1.68	5.55	6.13	0.69	17.44
CO [g/h]	247.17	23.48	32.42	351.21	117.25	388.08	428.25	47.96	1219.29
NOx [g/h]	48.09	4.57	6.31	68.33	22.81	75.51	83.32	9.33	237.23
VOC [g/h]	57.28	5.44	7.51	81.40	27.17	89.94	99.25	11.12	282.58

**Other Modes**

g_Walk,mi, Effective Walk Time [s]	8.0	8.0	8.0	8.0
M_corner, Corner Circulation Area [ft <sup>2</sup> /ped]	0.00	0.00	0.00	0.00
M_CW, Crosswalk Circulation Area [ft <sup>2</sup> /ped]	0.00	0.00	0.00	0.00
d_p, Pedestrian Delay [s]	32.52	32.52	32.52	32.52
I_p,int, Pedestrian LOS Score for Intersectio	2.163	2.081	2.579	2.262
Crosswalk LOS	B	B	B	B
s_b, Saturation Flow Rate of the bicycle lane	2000	2000	2000	2000
c_b, Capacity of the bicycle lane [bicycles/h]	748	498	623	623
d_b, Bicycle Delay [s]	15.75	22.61	19.12	19.02
I_b,int, Bicycle LOS Score for Intersection	2.093	2.109	2.718	2.611
Bicycle LOS	B	B	B	B

**Sequence**

Ring 1	1	2	3	4	-	-	-	-	-	-	-	-	-	-	-
Ring 2	5	6	7	8	-	-	-	-	-	-	-	-	-	-	-
Ring 3	-	-	-	-	-	-	-	-	-	-	-	-	-	-	-
Ring 4	-	-	-	-	-	-	-	-	-	-	-	-	-	-	-

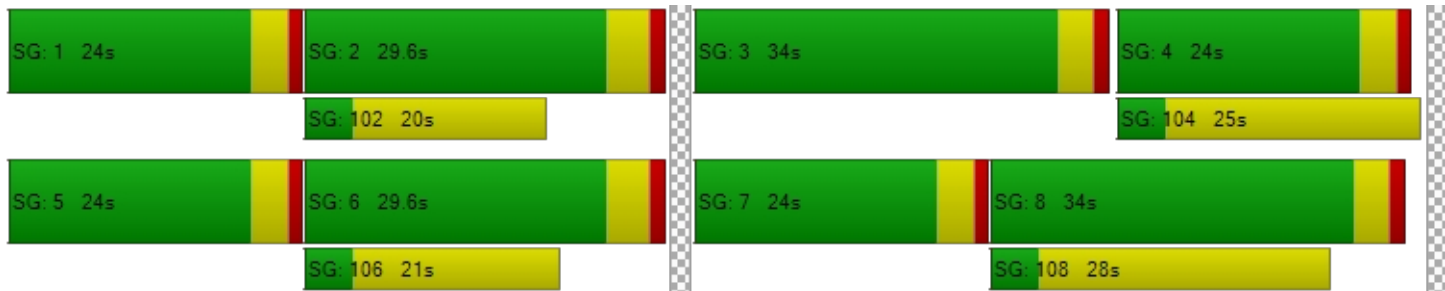

**Intersection Level Of Service Report**

**Intersection 15: Central Parkway & Panorama Drive/Pino Grande Road**

Control Type:	All-way stop	Delay (sec / veh):	13.3
Analysis Method:	HCM 7th Edition	Level Of Service:	B
Analysis Period:	15 minutes	Volume to Capacity (v/c):	0.465

**Intersection Setup**

Name	Pino Grande Road			Panorama Drive			Central Parkway			Central Parkway		
Approach	Northbound			Southbound			Eastbound			Westbound		
Lane Configuration	+			+r			+l			+l		
Turning Movement	Left	Thru	Right	Left	Thru	Right	Left	Thru	Right	Left	Thru	Right
Lane Width [ft]	12.00	12.00	12.00	12.00	12.00	12.00	12.00	12.00	12.00	12.00	12.00	12.00
No. of Lanes in Entry Pocket	0	0	0	0	0	1	1	0	0	1	0	0
Entry Pocket Length [ft]	100.00	100.00	100.00	100.00	100.00	100.00	275.00	100.00	100.00	100.00	100.00	100.00
No. of Lanes in Exit Pocket	0	0	0	0	0	0	0	0	0	0	0	0
Exit Pocket Length [ft]	0.00	0.00	0.00	0.00	0.00	0.00	0.00	0.00	0.00	0.00	0.00	0.00
Speed [mph]	30.00			30.00			30.00			30.00		
Grade [%]	0.00			0.00			0.00			0.00		
Crosswalk	Yes			Yes			Yes			Yes		

**Volumes**

Name	Pino Grande Road			Panorama Drive			Central Parkway			Central Parkway		
Base Volume Input [veh/h]	92	2	0	1	4	127	97	84	6	0	135	2
Base Volume Adjustment Factor	1.0000	1.0000	1.0000	1.0000	1.0000	1.0000	1.0000	1.0000	1.0000	1.0000	1.0000	1.0000
Heavy Vehicles Percentage [%]	0.00	0.00	0.00	0.00	0.00	0.00	2.10	1.20	0.00	0.00	0.00	0.00
Growth Factor	1.0000	1.0000	1.0000	1.0000	1.0000	1.0000	1.0000	1.0000	1.0000	1.0000	1.0000	1.0000
In-Process Volume [veh/h]	0	0	0	0	0	0	0	0	0	0	0	0
Site-Generated Trips [veh/h]	0	0	0	0	0	0	0	0	0	0	0	0
Diverted Trips [veh/h]	0	0	0	0	0	0	0	0	0	0	0	0
Pass-by Trips [veh/h]	0	0	0	0	0	0	0	0	0	0	0	0
Existing Site Adjustment Volume [veh/h]	0	0	0	0	0	0	0	0	0	0	0	0
Other Volume [veh/h]	0	0	0	0	0	0	0	0	0	0	0	0
Total Hourly Volume [veh/h]	92	2	0	1	4	127	97	84	6	0	135	2
Peak Hour Factor	0.5300	0.5300	0.5300	0.5300	0.5300	0.5300	0.5300	0.5300	0.5300	0.5300	0.5300	0.5300
Other Adjustment Factor	1.0000	1.0000	1.0000	1.0000	1.0000	1.0000	1.0000	1.0000	1.0000	1.0000	1.0000	1.0000
Total 15-Minute Volume [veh/h]	43	1	0	0	2	60	46	40	3	0	64	1
Total Analysis Volume [veh/h]	174	4	0	2	8	240	183	158	11	0	255	4
Pedestrian Volume [ped/h]	117			1			103			89		



**Intersection Settings**

**Lanes**

Capacity per Entry Lane [veh/h]	511	527	598	521	569	556	557
Degree of Utilization, x	0.35	0.02	0.40	0.35	0.30	0.00	0.47

**Movement, Approach, & Intersection Results**

95th-Percentile Queue Length [veh]	1.55	0.06	1.93	1.56	1.24	0.00	2.45
95th-Percentile Queue Length [ft]	38.63	1.45	48.26	39.08	30.95	0.00	61.25
Approach Delay [s/veh]	13.76	12.59		12.51		14.67	
Approach LOS	B	B		B		B	
Intersection Delay [s/veh]	13.28						
Intersection LOS	B						



**Intersection Level Of Service Report**  
**Intersection 16: Airway Boulevard & N. Canyons Parkway**

Control Type:	Signalized	Delay (sec / veh):	17.9
Analysis Method:	HCM 7th Edition	Level Of Service:	B
Analysis Period:	15 minutes	Volume to Capacity (v/c):	0.436

**Intersection Setup**

Name	Airway Boulevard			Driveway			N. Canyons Parkway			N Canyons Parkway		
Approach	Northbound			Southbound			Eastbound			Westbound		
Lane Configuration												
Turning Movement	Left	Thru	Right	Left	Thru	Right	Left	Thru	Right	Left	Thru	Right
Lane Width [ft]	12.00	12.00	12.00	12.00	12.00	12.00	12.00	12.00	12.00	12.00	12.00	12.00
No. of Lanes in Entry Pocket	0	0	0	0	0	0	0	0	0	1	0	1
Entry Pocket Length [ft]	100.00	100.00	100.00	100.00	100.00	100.00	100.00	100.00	100.00	110.00	100.00	195.00
No. of Lanes in Exit Pocket	0	0	0	0	0	0	0	0	0	0	0	0
Exit Pocket Length [ft]	0.00	0.00	0.00	0.00	0.00	0.00	0.00	0.00	0.00	0.00	0.00	0.00
Speed [mph]	40.00			30.00			40.00			40.00		
Grade [%]	0.00			0.00			0.00			0.00		
Curb Present	Yes			Yes			Yes			Yes		
Crosswalk	Yes			Yes			Yes			No		



**Volumes**

Name	Airway Boulevard			Driveway			N. Canyons Parkway			N Canyons Parkway		
Base Volume Input [veh/h]	288	14	469	1	4	0	0	40	77	395	298	1
Base Volume Adjustment Factor	1.0000	1.0000	1.0000	1.0000	1.0000	1.0000	1.0000	1.0000	1.0000	1.0000	1.0000	1.0000
Heavy Vehicles Percentage [%]	3.60	0.00	2.10	0.00	0.00	0.00	2.00	0.00	22.60	4.40	0.00	0.00
Proportion of CAVs [%]	0.00											
Growth Factor	1.0000	1.0000	1.0000	1.0000	1.0000	1.0000	1.0000	1.0000	1.0000	1.0000	1.0000	1.0000
In-Process Volume [veh/h]	0	0	0	0	0	0	0	0	0	0	0	0
Site-Generated Trips [veh/h]	0	0	0	0	0	0	0	0	0	0	0	0
Diverted Trips [veh/h]	0	0	0	0	0	0	0	0	0	0	0	0
Pass-by Trips [veh/h]	0	0	0	0	0	0	0	0	0	0	0	0
Existing Site Adjustment Volume [veh/h]	0	0	0	0	0	0	0	0	0	0	0	0
Other Volume [veh/h]	0	0	0	0	0	0	0	0	0	0	0	0
Right Turn on Red Volume [veh/h]	0	0	0	0	0	0	0	0	0	0	0	0
Total Hourly Volume [veh/h]	288	14	469	1	4	0	0	40	77	395	298	1
Peak Hour Factor	0.8900	0.8900	0.8900	0.8900	0.8900	0.8900	1.0000	0.8900	0.8900	0.8900	0.8900	0.8900
Other Adjustment Factor	1.0000	1.0000	1.0000	1.0000	1.0000	1.0000	1.0000	1.0000	1.0000	1.0000	1.0000	1.0000
Total 15-Minute Volume [veh/h]	81	4	132	0	1	0	0	11	22	111	84	0
Total Analysis Volume [veh/h]	324	16	527	1	4	0	0	45	87	444	335	1
Presence of On-Street Parking	No		No	No		No	No		No	No		No
On-Street Parking Maneuver Rate [/h]	0	0	0	0	0	0	0	0	0	0	0	0
Local Bus Stopping Rate [/h]	0	0	0	0	0	0	0	0	0	0	0	0
v_do, Outbound Pedestrian Volume crossing	0			0			0			0		
v_di, Inbound Pedestrian Volume crossing m	0			0			0			0		
v_co, Outbound Pedestrian Volume crossing	0			1			0			0		
v_ci, Inbound Pedestrian Volume crossing mi	0			0			0			1		
v_ab, Corner Pedestrian Volume [ped/h]	0			0			0			0		
Bicycle Volume [bicycles/h]	0			0			0			0		



**Intersection Settings**

Located in CBD	No
Signal Coordination Group	-
Cycle Length [s]	105
Active Pattern	Pattern 1
Coordination Type	Time of Day Pattern Coordinated
Actuation Type	Fully actuated
Offset [s]	0.0
Offset Reference	Lead Green - Beginning of First Green
Permissive Mode	SingleBand
Lost time [s]	12.00

**Phasing & Timing (Basic)**

Control Type	Split	Split	Overlap	Split	Split	Split	Permiss	Permiss	Permiss	Protecte	Permiss	Permiss
Signal Group	0	8	8	0	4	0	0	2	0	1	6	0
Auxiliary Signal Groups			1,8									
Maximum Green [s]	0	20	20	0	12	0	0	15	0	50	50	0
Amber [s]	0.0	3.2	3.2	0.0	3.0	0.0	0.0	5.0	0.0	5.0	5.0	0.0
All red [s]	0.0	1.0	1.0	0.0	1.0	0.0	0.0	1.0	0.0	1.0	1.0	0.0
Walk [s]	0	0	0	0	5	0	0	5	0	0	5	0
Pedestrian Clearance [s]	0	0	0	0	28	0	0	29	0	0	12	0
Delayed Vehicle Green [s]	0.0	0.0	0.0	0.0	0.0	0.0	0.0	0.0	0.0	0.0	0.0	0.0
Rest In Walk		No			No			No			No	
I1, Start-Up Lost Time [s]	0.0	2.0	2.0	0.0	2.0	0.0	0.0	2.0	0.0	2.0	2.0	0.0
I2, Clearance Lost Time [s]	0.0	2.0	2.0	0.0	2.0	0.0	0.0	2.0	0.0	2.0	2.0	0.0
Detector Location [ft]	0.0	0.0	0.0	0.0	0.0	0.0	0.0	0.0	0.0	0.0	0.0	0.0
Detector Length [ft]	0.0	20.0	20.0	0.0	20.0	0.0	0.0	20.0	0.0	20.0	20.0	0.0
I, Upstream Filtering Factor	1.00	1.00	1.00	1.00	1.00	1.00	1.00	1.00	1.00	1.00	1.00	1.00

**Phasing & Timing: Pattern 1**

Split [s]	0	25	25	0	20	0	0	30	0	30	60	0
Lead / Lag	-	-	-	-	-	-	-	-	-	Lead	-	-
Minimum Green [s]	0	4	4	0	3	0	0	10	0	3	7	0
Vehicle Extension [s]	0.0	2.0	2.0	0.0	2.0	0.0	0.0	2.0	0.0	2.0	2.0	0.0
Minimum Recall		No	No		No			No		No	Yes	
Maximum Recall		No	No		No			No		Yes	Yes	
Pedestrian Recall		No	No		No			No		No	No	

**Exclusive Pedestrian Phase**

Pedestrian Signal Group	0
Pedestrian Walk [s]	0
Pedestrian Clearance [s]	0





**Lane Group Calculations**

Lane Group	C	R	C	C	R	L	C	R
C, Cycle Length [s]	105	105	105	105	105	105	105	105
L, Total Lost Time per Cycle [s]	4.00	4.00	4.00	4.00	4.00	4.00	4.00	4.00
l1_p, Permitted Start-Up Lost Time [s]	0.00	0.00	0.00	0.00	0.00	0.00	0.00	0.00
l2, Clearance Lost Time [s]	2.00	0.00	2.00	2.00	2.00	2.00	2.00	2.00
g_i, Effective Green Time [s]	23	81	0	12	12	54	70	70
g / C, Green / Cycle	0.22	0.77	0.00	0.11	0.11	0.52	0.67	0.67
(v / s)_i Volume / Saturation Flow Rate	0.19	0.19	0.00	0.01	0.07	0.13	0.18	0.00
s, saturation flow rate [veh/h]	1814	2811	1881	3618	1327	3392	1900	1614
c, Capacity [veh/h]	391	2108	8	407	149	1749	1266	1075
d1, Uniform Delay [s]	39.80	4.04	52.21	41.90	44.28	14.18	7.11	5.86
k, delay calibration	0.04	0.50	0.04	0.04	0.04	0.50	0.50	0.50
l, Upstream Filtering Factor	1.00	1.00	1.00	1.00	1.00	1.00	1.00	1.00
d2, Incremental Delay [s]	2.39	0.28	24.85	0.04	1.35	0.35	0.51	0.00
d3, Initial Queue Delay [s]	0.00	0.00	0.00	0.00	0.00	0.00	0.00	0.00
Rp, platoon ratio	1.00	1.00	1.00	1.00	1.00	1.00	1.00	1.00
PF, progression factor	1.00	1.00	1.00	1.00	1.00	1.00	1.00	1.00

**Lane Group Results**

X, volume / capacity	0.87	0.25	0.62	0.11	0.58	0.25	0.26	0.00
d, Delay for Lane Group [s/veh]	42.18	4.33	77.06	41.94	45.63	14.53	7.62	5.86
Lane Group LOS	D	A	E	D	D	B	A	A
Critical Lane Group	Yes	No	Yes	No	Yes	Yes	No	No
50th-Percentile Queue Length [veh/ln]	8.44	1.36	0.19	0.52	2.16	2.84	2.78	0.01
50th-Percentile Queue Length [ft/ln]	211.06	34.09	4.68	12.91	53.90	70.98	69.51	0.17
95th-Percentile Queue Length [veh/ln]	13.21	2.45	0.34	0.93	3.88	5.11	5.00	0.01
95th-Percentile Queue Length [ft/ln]	330.19	61.36	8.43	23.24	97.02	127.77	125.12	0.31

**Movement, Approach, & Intersection Results**

d_M, Delay for Movement [s/veh]	42.18	42.18	4.33	77.06	77.06	77.06	0.00	41.94	45.63	14.53	7.62	5.86
Movement LOS	D	D	A	E	E	E		D	D	B	A	A
d_A, Approach Delay [s/veh]	19.17			77.06				44.37		11.55		
Approach LOS	B			E				D		B		
d_I, Intersection Delay [s/veh]	17.87											
Intersection LOS	B											
Intersection V/C	0.436											

**Emissions**

Vehicle Miles Traveled [mph]	40.37	62.58	0.17	2.93	5.67	36.31	27.40	0.08
Stops [stops/h]	289.39	93.49	6.42	35.41	73.90	194.65	95.31	0.24
Fuel consumption [US gal/h]	7.21	3.62	0.12	0.84	1.74	4.53	2.44	0.01
CO [g/h]	503.80	253.30	8.45	58.50	121.41	316.37	170.37	0.45
NOx [g/h]	98.02	49.28	1.64	11.38	23.62	61.55	33.15	0.09
VOC [g/h]	116.76	58.71	1.96	13.56	28.14	73.32	39.48	0.10

**Other Modes**

g_Walk,mi, Effective Walk Time [s]	9.0	9.0	9.0	0.0
M_corner, Corner Circulation Area [ft <sup>2</sup> /ped]	0.00	0.00	0.00	0.00
M_CW, Crosswalk Circulation Area [ft <sup>2</sup> /ped]	0.00	5853.56	0.00	0.00
d_p, Pedestrian Delay [s]	43.90	43.90	43.90	0.00
I_p,int, Pedestrian LOS Score for Intersectio	2.766	1.735	2.514	0.000
Crosswalk LOS	C	A	B	F
s_b, Saturation Flow Rate of the bicycle lane	2000	2000	2000	2000
c_b, Capacity of the bicycle lane [bicycles/h]	396	305	457	1028
d_b, Bicycle Delay [s]	33.77	37.73	31.25	12.39
I_b,int, Bicycle LOS Score for Intersection	2.990	1.568	1.669	2.847
Bicycle LOS	C	A	A	C

**Sequence**

Ring 1	1	2	4	8	-	-	-	-	-	-	-	-	-	-	-
Ring 2	-	6	-	-	-	-	-	-	-	-	-	-	-	-	-
Ring 3	-	-	-	-	-	-	-	-	-	-	-	-	-	-	-
Ring 4	-	-	-	-	-	-	-	-	-	-	-	-	-	-	-



**Intersection Level Of Service Report**  
**Intersection 17: Airway Boulevard & I-580 WB Ramps**

Control Type:	Signalized	Delay (sec / veh):	13.4
Analysis Method:	HCM 7th Edition	Level Of Service:	B
Analysis Period:	15 minutes	Volume to Capacity (v/c):	0.254

**Intersection Setup**

Name	Airway Boulevard			Airway Boulevard			I-580 WB On-Ramp			I-580 WB Off-Ramp		
Approach	Northbound			Southbound			Eastbound			Westbound		
Lane Configuration	r			r						r rr		
Turning Movement	Left	Thru	Right	Left	Thru	Right	Left	Thru	Right	Left	Thru	Right
Lane Width [ft]	12.00	12.00	12.00	12.00	12.00	12.00	12.00	12.00	12.00	12.00	12.00	12.00
No. of Lanes in Entry Pocket	0	0	0	0	0	1	0	0	0	1	0	1
Entry Pocket Length [ft]	100.00	100.00	100.00	100.00	100.00	250.00	100.00	100.00	100.00	150.00	100.00	490.00
No. of Lanes in Exit Pocket	0	0	0	0	0	0	0	0	0	0	0	0
Exit Pocket Length [ft]	0.00	0.00	0.00	0.00	0.00	0.00	0.00	0.00	0.00	0.00	0.00	0.00
Speed [mph]	40.00			40.00			30.00			45.00		
Grade [%]	0.00			0.00			0.00			0.00		
Curb Present	Yes			Yes						Yes		
Crosswalk	No			No			No			Yes		



**Volumes**

Name	Airway Boulevard			Airway Boulevard			I-580 WB On-Ramp			I-580 WB Off-Ramp		
	Base Volume Input [veh/h]	0	666	138	0	170	363	0	0	0	48	0
Base Volume Adjustment Factor	1.0000	1.0000	1.0000	1.0000	1.0000	1.0000	1.0000	1.0000	1.0000	1.0000	1.0000	1.0000
Heavy Vehicles Percentage [%]	2.00	2.90	9.20	2.00	5.70	6.80	2.00	2.00	2.00	4.20	0.00	8.50
Proportion of CAVs [%]	0.00											
Growth Factor	1.0000	1.0000	1.0000	1.0000	1.0000	1.0000	1.0000	1.0000	1.0000	1.0000	1.0000	1.0000
In-Process Volume [veh/h]	0	0	0	0	0	0	0	0	0	0	0	0
Site-Generated Trips [veh/h]	0	0	0	0	0	0	0	0	0	0	0	0
Diverted Trips [veh/h]	0	0	0	0	0	0	0	0	0	0	0	0
Pass-by Trips [veh/h]	0	0	0	0	0	0	0	0	0	0	0	0
Existing Site Adjustment Volume [veh/h]	0	0	0	0	0	0	0	0	0	0	0	0
Other Volume [veh/h]	0	0	0	0	0	0	0	0	0	0	0	0
Right Turn on Red Volume [veh/h]	0	0	0	0	0	0	0	0	0	0	0	0
Total Hourly Volume [veh/h]	0	666	138	0	170	363	0	0	0	48	0	284
Peak Hour Factor	1.0000	0.8700	0.8700	1.0000	0.8700	0.8700	1.0000	1.0000	1.0000	0.8700	0.8700	0.8700
Other Adjustment Factor	1.0000	1.0000	1.0000	1.0000	1.0000	1.0000	1.0000	1.0000	1.0000	1.0000	1.0000	1.0000
Total 15-Minute Volume [veh/h]	0	191	40	0	49	104	0	0	0	14	0	82
Total Analysis Volume [veh/h]	0	766	159	0	195	417	0	0	0	55	0	326
Presence of On-Street Parking	No		No	No		No				No		No
On-Street Parking Maneuver Rate [/h]	0	0	0	0	0	0	0	0	0	0	0	0
Local Bus Stopping Rate [/h]	0	0	0	0	0	0	0	0	0	0	0	0
v_do, Outbound Pedestrian Volume crossing	0			0			0			0		
v_di, Inbound Pedestrian Volume crossing m	0			0			0			0		
v_co, Outbound Pedestrian Volume crossing	1			0			0			1		
v_ci, Inbound Pedestrian Volume crossing mi	1			0			0			1		
v_ab, Corner Pedestrian Volume [ped/h]	0			0			0			0		
Bicycle Volume [bicycles/h]	0			0			0			0		



**Intersection Settings**

Located in CBD	No
Signal Coordination Group	-
Cycle Length [s]	105
Active Pattern	Pattern 1
Coordination Type	Time of Day Pattern Coordinated
Actuation Type	Fully actuated
Offset [s]	91.0
Offset Reference	Lead Green - Beginning of First Green
Permissive Mode	SingleBand
Lost time [s]	9.00

**Phasing & Timing (Basic)**

Control Type	Permiss	Permiss	Unsigna	Permiss	Permiss	Unsigna	Permiss	Permiss	Permiss	Permiss	Permiss	Overlap
Signal Group	0	2	0	0	6	0	0	0	0	0	8	1
Auxiliary Signal Groups												1,8
Maximum Green [s]	0	30	0	0	25	0	0	0	0	0	20	12
Amber [s]	0.0	4.3	0.0	0.0	4.3	0.0	0.0	0.0	0.0	0.0	3.0	3.0
All red [s]	0.0	1.0	0.0	0.0	1.0	0.0	0.0	0.0	0.0	0.0	1.0	0.0
Walk [s]	0	7	0	0	0	0	0	0	0	0	0	0
Pedestrian Clearance [s]	0	15	0	0	0	0	0	0	0	0	0	0
Delayed Vehicle Green [s]	0.0	0.0	0.0	0.0	0.0	0.0	0.0	0.0	0.0	0.0	0.0	0.0
Rest In Walk		No			No						No	
I1, Start-Up Lost Time [s]	0.0	2.0	0.0	0.0	2.0	0.0	0.0	0.0	0.0	0.0	2.0	2.0
I2, Clearance Lost Time [s]	0.0	2.0	0.0	0.0	2.0	0.0	0.0	0.0	0.0	0.0	2.0	2.0
Detector Location [ft]	0.0	0.0	0.0	0.0	0.0	0.0	0.0	0.0	0.0	0.0	0.0	0.0
Detector Length [ft]	0.0	20.0	0.0	0.0	20.0	0.0	0.0	0.0	0.0	0.0	20.0	20.0
I, Upstream Filtering Factor	1.00	1.00	1.00	1.00	1.00	1.00	1.00	1.00	1.00	1.00	1.00	1.00

**Phasing & Timing: Pattern 1**

Split [s]	0	74	0	0	89	0	0	0	0	0	16	15
Lead / Lag	-	-	-	-	-	-	-	-	-	-	-	-
Minimum Green [s]	0	11	0	0	8	0	0	0	0	0	4	4
Vehicle Extension [s]	0.0	0.0	0.0	0.0	0.0	0.0	0.0	0.0	0.0	0.0	0.0	0.0
Minimum Recall		Yes			Yes						No	No
Maximum Recall		No			No						No	No
Pedestrian Recall		No			No						No	No

**Exclusive Pedestrian Phase**

Pedestrian Signal Group	0
Pedestrian Walk [s]	0
Pedestrian Clearance [s]	0



**Lane Group Calculations**

Lane Group	C	C		L	C	R
C, Cycle Length [s]	105	105		105	105	105
L, Total Lost Time per Cycle [s]	4.00	4.00		4.00	4.00	4.00
l1_p, Permitted Start-Up Lost Time [s]	0.00	0.00		0.00	0.00	0.00
l2, Clearance Lost Time [s]	2.00	2.00		2.00	2.00	0.00
g_i, Effective Green Time [s]	70	85		12	12	27
g / C, Green / Cycle	0.67	0.81		0.11	0.11	0.26
(v / s)_i Volume / Saturation Flow Rate	0.22	0.04		0.02	0.02	0.12
s, saturation flow rate [veh/h]	3535	4943		1749	1810	2667
c, Capacity [veh/h]	2356	4000		200	207	711
d1, Uniform Delay [s]	7.45	1.99		41.81	41.79	32.14
k, delay calibration	0.50	0.50		0.04	0.04	0.04
l, Upstream Filtering Factor	1.00	1.00		1.00	1.00	1.00
d2, Incremental Delay [s]	0.37	0.02		0.11	0.11	0.17
d3, Initial Queue Delay [s]	0.00	0.00		0.00	0.00	0.00
Rp, platoon ratio	1.00	1.00		1.00	1.00	1.00
PF, progression factor	1.00	1.00		1.00	1.00	1.00

**Lane Group Results**

X, volume / capacity	0.33	0.05		0.14	0.13	0.46
d, Delay for Lane Group [s/veh]	7.82	2.01		41.92	41.89	32.31
Lane Group LOS	A	A		D	D	C
Critical Lane Group	Yes	No		No	No	Yes
50th-Percentile Queue Length [veh/ln]	3.24	0.16		0.63	0.63	3.33
50th-Percentile Queue Length [ft/ln]	81.04	3.97		15.71	15.69	83.14
95th-Percentile Queue Length [veh/ln]	5.84	0.29		1.13	1.13	5.99
95th-Percentile Queue Length [ft/ln]	145.88	7.14		28.27	28.25	149.64

**Movement, Approach, & Intersection Results**

d_M, Delay for Movement [s/veh]	0.00	7.82	0.00	0.00	2.01	0.00	0.00	0.00	0.00	0.00	41.92	41.89	32.31
Movement LOS		A			A						D	D	C
d_A, Approach Delay [s/veh]	6.62				0.70				0.00		33.70		
Approach LOS	A				A				A		C		
d_I, Intersection Delay [s/veh]	13.45												
Intersection LOS	B												
Intersection V/C	0.254												

**Emissions**

Vehicle Miles Traveled [mph]	63.90	23.15		2.70	2.70	32.06
Stops [stops/h]	222.35	16.32		21.55	21.53	228.09
Fuel consumption [US gal/h]	5.69	1.07		0.60	0.59	6.08
CO [g/h]	397.86	74.76		41.61	41.58	424.88
NOx [g/h]	77.41	14.54		8.09	8.09	82.67
VOC [g/h]	92.21	17.33		9.64	9.64	98.47

**Other Modes**

g_Walk,mi, Effective Walk Time [s]	0.0	0.0	0.0	11.0
M_corner, Corner Circulation Area [ft <sup>2</sup> /ped]	0.00	0.00	0.00	0.00
M_CW, Crosswalk Circulation Area [ft <sup>2</sup> /ped]	0.00	0.00	0.00	0.00
d_p, Pedestrian Delay [s]	0.00	0.00	0.00	42.06
I_p,int, Pedestrian LOS Score for Intersectio	0.000	0.000	0.000	2.419
Crosswalk LOS	F	F	F	B
s_b, Saturation Flow Rate of the bicycle lane	2000	2000	2000	2000
c_b, Capacity of the bicycle lane [bicycles/h]	1309	1595	0	229
d_b, Bicycle Delay [s]	6.27	2.15	52.49	41.17
I_b,int, Bicycle LOS Score for Intersection	2.192	1.667	4.132	2.188
Bicycle LOS	B	A	D	B

**Sequence**

Ring 1	1	2	-	-	-	-	-	-	-	-	-	-	-	-	-
Ring 2	-	6	-	8	-	-	-	-	-	-	-	-	-	-	-
Ring 3	-	-	-	-	-	-	-	-	-	-	-	-	-	-	-
Ring 4	-	-	-	-	-	-	-	-	-	-	-	-	-	-	-



**Intersection Level Of Service Report**

**Intersection 19: Pandora Way & Residential Project Access Driveway (Parcel 7)**

Control Type:	All-way stop	Delay (sec / veh):	7.1
Analysis Method:	HCM 7th Edition	Level Of Service:	A
Analysis Period:	15 minutes	Volume to Capacity (v/c):	0.060

**Intersection Setup**

Name	Residential Project Access (Parcel 7)		Pino Grande Road		Pandora Way	
Approach	Northbound		Southbound		Westbound	
Lane Configuration	↬		↵		↶	
Turning Movement	Thru	Right	Left	Thru	Left	Right
Lane Width [ft]	12.00	12.00	12.00	12.00	12.00	12.00
No. of Lanes in Entry Pocket	0	0	0	0	0	0
Entry Pocket Length [ft]	100.00	100.00	100.00	100.00	100.00	100.00
No. of Lanes in Exit Pocket	0	0	0	0	0	0
Exit Pocket Length [ft]	0.00	0.00	0.00	0.00	0.00	0.00
Speed [mph]	30.00		30.00		30.00	
Grade [%]	0.00		0.00		0.00	
Crosswalk	Yes		Yes		Yes	

**Volumes**

Name	Residential Project Access (Parcel 7)		Pino Grande Road		Pandora Way	
Base Volume Input [veh/h]	55	0	5	0	0	5
Base Volume Adjustment Factor	1.0000	1.0000	1.0000	1.0000	1.0000	1.0000
Heavy Vehicles Percentage [%]	2.00	2.00	2.00	2.00	2.00	2.00
Growth Factor	1.0000	1.0000	1.0000	1.0000	1.0000	1.0000
In-Process Volume [veh/h]	0	0	0	0	0	0
Site-Generated Trips [veh/h]	0	0	0	0	0	0
Diverted Trips [veh/h]	0	0	0	0	0	0
Pass-by Trips [veh/h]	0	0	0	0	0	0
Existing Site Adjustment Volume [veh/h]	0	0	0	0	0	0
Other Volume [veh/h]	0	0	0	0	0	0
Total Hourly Volume [veh/h]	55	0	5	0	0	5
Peak Hour Factor	1.0000	1.0000	1.0000	1.0000	1.0000	1.0000
Other Adjustment Factor	1.0000	1.0000	1.0000	1.0000	1.0000	1.0000
Total 15-Minute Volume [veh/h]	14	0	1	0	0	1
Total Analysis Volume [veh/h]	55	0	5	0	0	5
Pedestrian Volume [ped/h]	0		0		0	





**Intersection Settings****Lanes**

Capacity per Entry Lane [veh/h]	912	858	1041
Degree of Utilization, x	0.06	0.01	0.00

**Movement, Approach, & Intersection Results**

95th-Percentile Queue Length [veh]	0.19	0.02	0.01
95th-Percentile Queue Length [ft]	4.81	0.44	0.36
Approach Delay [s/veh]	7.20	7.22	6.48
Approach LOS	A	A	A
Intersection Delay [s/veh]	7.15		
Intersection LOS	A		

**Intersection Level Of Service Report**  
**Intersection 20: Croak Road & Central Parkway**

Control Type:	All-way stop	Delay (sec / veh):	7.9
Analysis Method:	HCM 7th Edition	Level Of Service:	A
Analysis Period:	15 minutes	Volume to Capacity (v/c):	0.062

**Intersection Setup**

Name	Croak Road		Croak Road		Central Parkway	
Approach	Northbound		Southbound		Eastbound	
Lane Configuration						
Turning Movement	Left	Thru	Thru	Right	Left	Right
Lane Width [ft]	12.00	12.00	12.00	12.00	12.00	12.00
No. of Lanes in Entry Pocket	1	0	1	0	1	0
Entry Pocket Length [ft]	215.00	100.00	175.00	100.00	185.00	100.00
No. of Lanes in Exit Pocket	0	0	0	0	0	0
Exit Pocket Length [ft]	0.00	0.00	0.00	0.00	0.00	0.00
Speed [mph]	30.00		30.00		25.00	
Grade [%]	0.00		0.00		0.00	
Crosswalk	Yes		Yes		Yes	

**Volumes**

Name	Croak Road		Croak Road		Central Parkway	
Base Volume Input [veh/h]	44	0	0	0	0	7
Base Volume Adjustment Factor	1.0000	1.0000	1.0000	1.0000	1.0000	1.0000
Heavy Vehicles Percentage [%]	2.00	2.00	2.00	2.00	2.00	2.00
Growth Factor	1.0000	1.0000	1.0000	1.0000	1.0000	1.0000
In-Process Volume [veh/h]	0	0	0	0	0	0
Site-Generated Trips [veh/h]	0	0	0	0	0	0
Diverted Trips [veh/h]	0	0	0	0	0	0
Pass-by Trips [veh/h]	0	0	0	0	0	0
Existing Site Adjustment Volume [veh/h]	0	0	0	0	0	0
Other Volume [veh/h]	0	0	0	0	0	0
Total Hourly Volume [veh/h]	44	0	0	0	0	7
Peak Hour Factor	1.0000	1.0000	1.0000	1.0000	1.0000	1.0000
Other Adjustment Factor	1.0000	1.0000	1.0000	1.0000	1.0000	1.0000
Total 15-Minute Volume [veh/h]	11	0	0	0	0	2
Total Analysis Volume [veh/h]	44	0	0	0	0	7
Pedestrian Volume [ped/h]	0		0		0	



**Intersection Settings****Lanes**

Capacity per Entry Lane [veh/h]	713	792	786	774	910
Degree of Utilization, x	0.06	0.00	0.00	0.00	0.01

**Movement, Approach, & Intersection Results**

95th-Percentile Queue Length [veh]	0.20	0.00	0.00	0.00	0.02
95th-Percentile Queue Length [ft]	4.92	0.00	0.00	0.00	0.58
Approach Delay [s/veh]	8.08		0.00	6.68	
Approach LOS	A		A	A	
Intersection Delay [s/veh]	7.89				
Intersection LOS	A				

**Intersection Level Of Service Report**  
**Intersection 21: Croak Road & Project Access (Parcel 8)**

Control Type:	Two-way stop	Delay (sec / veh):	8.5
Analysis Method:	HCM 7th Edition	Level Of Service:	A
Analysis Period:	15 minutes	Volume to Capacity (v/c):	0.041

**Intersection Setup**

Name	Croak Road		Croak Road		Project Access (Parcel 8)	
Approach	Northbound		Southbound		Westbound	
Lane Configuration	↩		↪		↩	
Turning Movement	Thru	Right	Left	Thru	Left	Right
Lane Width [ft]	12.00	12.00	12.00	12.00	12.00	12.00
No. of Lanes in Entry Pocket	0	0	0	0	0	0
Entry Pocket Length [ft]	100.00	100.00	100.00	100.00	100.00	100.00
No. of Lanes in Exit Pocket	0	0	0	0	0	0
Exit Pocket Length [ft]	0.00	0.00	0.00	0.00	0.00	0.00
Speed [mph]	30.00		30.00		30.00	
Grade [%]	0.00		0.00		0.00	
Crosswalk	Yes		Yes		Yes	

**Volumes**

Name	Croak Road		Croak Road		Project Access (Parcel 8)	
Base Volume Input [veh/h]	0	0	7	0	0	44
Base Volume Adjustment Factor	1.0000	1.0000	1.0000	1.0000	1.0000	1.0000
Heavy Vehicles Percentage [%]	2.00	2.00	2.00	2.00	2.00	2.00
Growth Factor	1.0000	1.0000	1.0000	1.0000	1.0000	1.0000
In-Process Volume [veh/h]	0	0	0	0	0	0
Site-Generated Trips [veh/h]	0	0	0	0	0	0
Diverted Trips [veh/h]	0	0	0	0	0	0
Pass-by Trips [veh/h]	0	0	0	0	0	0
Existing Site Adjustment Volume [veh/h]	0	0	0	0	0	0
Other Volume [veh/h]	0	0	0	0	0	0
Total Hourly Volume [veh/h]	0	0	7	0	0	44
Peak Hour Factor	1.0000	1.0000	1.0000	1.0000	1.0000	1.0000
Other Adjustment Factor	1.0000	1.0000	1.0000	1.0000	1.0000	1.0000
Total 15-Minute Volume [veh/h]	0	0	2	0	0	11
Total Analysis Volume [veh/h]	0	0	7	0	0	44
Pedestrian Volume [ped/h]	0		0		0	



**Intersection Settings**

Priority Scheme	Free	Free	Stop
Flared Lane			No
Storage Area [veh]	0	0	0
Two-Stage Gap Acceptance			No
Number of Storage Spaces in Median	0	0	0

**Movement, Approach, & Intersection Results**

V/C, Movement V/C Ratio	0.00	0.00	0.00	0.00	0.00	0.04
d_M, Delay for Movement [s/veh]	0.00	0.00	7.23	0.00	8.74	8.46
Movement LOS	A	A	A	A	A	A
95th-Percentile Queue Length [veh/ln]	0.00	0.00	0.01	0.01	0.13	0.13
95th-Percentile Queue Length [ft/ln]	0.00	0.00	0.32	0.32	3.17	3.17
d_A, Approach Delay [s/veh]	0.00		7.23		8.46	
Approach LOS	A		A		A	
d_I, Intersection Delay [s/veh]	8.29					
Intersection LOS	A					



Vistro File: H:\...\PacVest\_20240229.vistro

Scenario 6 Near Term Plus Project PM

Report File: H:\...\NearTermPM\_PP\_LOS.pdf

3/1/2024

**Intersection Analysis Summary**

ID	Intersection Name	Control Type	Method	Worst Mvmt	V/C	Delay (s/veh)	LOS
1	Hacienda Drive & Dublin Boulevard	Signalized	HCM 7th Edition	SB Left	0.471	40.2	D
2	Tassajara Road & Central Parkway	Signalized	HCM 7th Edition	SB Left	0.552	32.0	C
3	Tassajara Road & Dublin Boulevard	Signalized	HCM 7th Edition	NB Right	0.845	53.0	D
4	Tassajara Road & I-580 WB Ramps	Signalized	HCM 7th Edition	WB Left	0.680	11.7	B
5	Santa Rita Rd & I-580 EB Ramps/Pimlico Dr	Signalized	HCM 7th Edition	SB Left	0.852	35.2	D
6	Tassajara Road & Fallon Road	Signalized	HCM 7th Edition	WB Left	0.427	15.6	B
7	Fallon Road & Positano Parkway	Signalized	HCM 7th Edition	SB Left	0.556	10.7	B
8	Fallon Road & Central Parkway	Signalized	HCM 7th Edition	SB Left	0.406	21.5	C
9	Fallon Road & Dublin Boulevard	Signalized	HCM 7th Edition	EB Left	0.680	34.2	C
10	Fallon Road & Fallon Gateway	Signalized	HCM 7th Edition	NB Left	0.625	13.3	B
11	Fallon Road & I-580 WB Ramps	Signalized	HCM 7th Edition	NB Thru	0.594	26.5	C
12	El Charro Road & I-580 EB Ramps	Signalized	HCM 7th Edition	EB Right	0.605	7.2	A
13	El Charro Road & Jack London Boulevard	Signalized	HCM 7th Edition	NB Right	0.719	13.9	B
14	Central Parkway & Sunset View Drive	Signalized	HCM 7th Edition	WB Left	0.307	11.2	B
15	Central Parkway & Panorama Drive/Pino Grande Road	All-way stop	HCM 7th Edition	EB Left	0.180	8.3	A
16	Airway Boulevard & N. Canyons Parkway	Signalized	HCM 7th Edition	SB Thru	0.618	25.1	C
17	Airway Boulevard & I-580 WB Ramps	Signalized	HCM 7th Edition	WB Left	0.251	9.0	A



19	Pandora Way & Residential Project Access Driveway (Parcel 7)	All-way stop	HCM 7th Edition	SB Thru	0.055	7.1	A
20	Croak Road & Central Parkway	All-way stop	HCM 7th Edition	NB Left	0.044	7.1	A
21	Croak Road & Project Access (Parcel 8)	Two-way stop	HCM 7th Edition	WB Right	0.014	8.4	A

V/C, Delay, LOS: For two-way stop, these values are taken from the movement with the worst (highest) delay value. For all other control types, they are taken for the whole intersection.

**Intersection Level Of Service Report**  
**Intersection 1: Hacienda Drive & Dublin Boulevard**

Control Type:	Signalized	Delay (sec / veh):	40.2
Analysis Method:	HCM 7th Edition	Level Of Service:	D
Analysis Period:	15 minutes	Volume to Capacity (v/c):	0.471

**Intersection Setup**

Name	Hacienda Drive			Hacienda Drive			Dublin Boulevard			Dublin Boulevard		
Approach	Northbound			Southbound			Eastbound			Westbound		
Lane Configuration	[Diagram]			[Diagram]			[Diagram]			[Diagram]		
Turning Movement	Left	Thru	Right	Left	Thru	Right	Left	Thru	Right	Left	Thru	Right
Lane Width [ft]	12.00	12.00	12.00	12.00	12.00	12.00	12.00	12.00	12.00	12.00	12.00	12.00
No. of Lanes in Entry Pocket	2	0	2	2	0	1	2	0	2	2	0	0
Entry Pocket Length [ft]	250.00	100.00	380.00	300.00	100.00	220.00	300.00	100.00	250.00	275.00	100.00	100.00
No. of Lanes in Exit Pocket	0	0	0	0	0	0	0	0	0	0	0	1
Exit Pocket Length [ft]	0.00	0.00	0.00	0.00	0.00	0.00	0.00	0.00	0.00	0.00	0.00	1000.00
Speed [mph]	35.00			35.00			40.00			40.00		
Grade [%]	0.00			0.00			0.00			0.00		
Curb Present	Yes			Yes			Yes			Yes		
Crosswalk	Yes			Yes			Yes			Yes		





**Volumes**

Name	Hacienda Drive			Hacienda Drive			Dublin Boulevard			Dublin Boulevard		
Base Volume Input [veh/h]	210	597	295	55	521	59	144	888	316	186	529	20
Base Volume Adjustment Factor	1.0000	1.0000	1.0000	1.0000	1.0000	1.0000	1.0000	1.0000	1.0000	1.0000	1.0000	1.0000
Heavy Vehicles Percentage [%]	0.00	0.20	0.80	0.00	0.20	5.10	1.90	1.10	1.50	1.30	1.60	0.00
Proportion of CAVs [%]	0.00											
Growth Factor	1.0000	1.0000	1.0000	1.0000	1.0000	1.0000	1.0000	1.0000	1.0000	1.0000	1.0000	1.0000
In-Process Volume [veh/h]	0	0	0	0	0	0	0	0	0	0	0	0
Site-Generated Trips [veh/h]	0	0	0	0	0	0	0	0	0	0	0	0
Diverted Trips [veh/h]	0	0	0	0	0	0	0	0	0	0	0	0
Pass-by Trips [veh/h]	0	0	0	0	0	0	0	0	0	0	0	0
Existing Site Adjustment Volume [veh/h]	0	0	0	0	0	0	0	0	0	0	0	0
Other Volume [veh/h]	0	0	0	0	0	0	0	0	0	0	0	0
Right Turn on Red Volume [veh/h]	0	0	0	0	0	0	0	0	0	0	0	0
Total Hourly Volume [veh/h]	210	597	295	55	521	59	144	888	316	186	529	20
Peak Hour Factor	0.9400	0.9400	0.9400	0.9400	0.9400	0.9400	0.9400	0.9400	0.9400	0.9400	0.9400	0.9400
Other Adjustment Factor	1.0000	1.0000	1.0000	1.0000	1.0000	1.0000	1.0000	1.0000	1.0000	1.0000	1.0000	1.0000
Total 15-Minute Volume [veh/h]	56	159	78	15	139	16	38	236	84	49	141	5
Total Analysis Volume [veh/h]	223	635	314	59	554	63	153	945	336	198	563	21
Presence of On-Street Parking	No		No	No		No	No		No	No		No
On-Street Parking Maneuver Rate [/h]	0	0	0	0	0	0	0	0	0	0	0	0
Local Bus Stopping Rate [/h]	0	0	0	0	0	0	0	0	0	0	0	0
v_do, Outbound Pedestrian Volume crossing	5			2			4			2		
v_di, Inbound Pedestrian Volume crossing m	4			2			5			2		
v_co, Outbound Pedestrian Volume crossing	6			1			2			7		
v_ci, Inbound Pedestrian Volume crossing mi	7			2			1			6		
v_ab, Corner Pedestrian Volume [ped/h]	0			0			0			0		
Bicycle Volume [bicycles/h]	1			0			4			1		



**Intersection Settings**

Located in CBD	No
Signal Coordination Group	-
Cycle Length [s]	150
Active Pattern	Pattern 1
Coordination Type	Time of Day Pattern Coordinated
Actuation Type	Fully actuated
Offset [s]	113.0
Offset Reference	Lead Green - Beginning of First Green
Permissive Mode	SingleBand
Lost time [s]	12.00

**Phasing & Timing (Basic)**

Control Type	Protecte	Permiss	Permiss	Protecte	Permiss	Permiss	Protecte	Permiss	Permiss	Protecte	Permiss	Permiss
Signal Group	3	8	0	7	4	0	5	2	0	1	6	0
Auxiliary Signal Groups												
Maximum Green [s]	20	50	0	20	50	0	20	60	0	20	60	0
Amber [s]	3.5	4.5	0.0	3.5	4.1	0.0	3.5	4.5	0.0	3.5	4.5	0.0
All red [s]	1.5	1.5	0.0	1.0	1.5	0.0	1.0	1.5	0.0	1.0	1.5	0.0
Walk [s]	0	4	0	0	4	0	0	4	0	0	4	0
Pedestrian Clearance [s]	0	32	0	0	40	0	0	43	0	0	35	0
Delayed Vehicle Green [s]	0.0	0.0	0.0	0.0	0.0	0.0	0.0	0.0	0.0	0.0	0.0	0.0
Rest In Walk		No			No			No			No	
I1, Start-Up Lost Time [s]	2.0	2.0	0.0	2.0	2.0	0.0	2.0	2.0	0.0	2.0	2.0	0.0
I2, Clearance Lost Time [s]	2.0	2.0	0.0	2.0	2.0	0.0	2.0	2.0	0.0	2.0	2.0	0.0
Detector Location [ft]	0.0	0.0	0.0	0.0	0.0	0.0	0.0	0.0	0.0	0.0	0.0	0.0
Detector Length [ft]	20.0	20.0	0.0	20.0	20.0	0.0	20.0	20.0	0.0	20.0	20.0	0.0
I, Upstream Filtering Factor	1.00	1.00	1.00	1.00	1.00	1.00	1.00	1.00	1.00	1.00	1.00	1.00

**Phasing & Timing: Pattern 1**

Split [s]	18	55	0	14	51	0	15	61	0	20	66	0
Lead / Lag	Lead	-	-	Lead	-	-	Lead	-	-	Lead	-	-
Minimum Green [s]	4	10	0	4	10	0	4	10	0	8	10	0
Vehicle Extension [s]	3.0	3.5	0.0	3.0	3.5	0.0	3.0	3.5	0.0	3.0	3.5	0.0
Minimum Recall	No	No		No	No		No	Yes		No	Yes	
Maximum Recall	No	No		No	No		No	No		No	No	
Pedestrian Recall	No	No		No	No		No	No		No	No	

**Exclusive Pedestrian Phase**

Pedestrian Signal Group	0
Pedestrian Walk [s]	0
Pedestrian Clearance [s]	0



**Lane Group Calculations**

Lane Group	L	C	R	L	C	R	L	C	R	L	C	C
C, Cycle Length [s]	150	150	150	150	150	150	150	150	150	150	150	150
L, Total Lost Time per Cycle [s]	4.00	4.00	4.00	4.00	4.00	4.00	4.00	4.00	4.00	4.00	4.00	4.00
l1_p, Permitted Start-Up Lost Time [s]	0.00	0.00	0.00	0.00	0.00	0.00	0.00	0.00	0.00	0.00	0.00	0.00
l2, Clearance Lost Time [s]	2.00	2.00	2.00	2.00	2.00	2.00	2.00	2.00	2.00	2.00	2.00	2.00
g_i, Effective Green Time [s]	10	34	34	5	29	29	9	84	84	11	86	86
g / C, Green / Cycle	0.06	0.23	0.23	0.03	0.20	0.20	0.06	0.56	0.56	0.07	0.57	0.57
(v / s)_i Volume / Saturation Flow Rate	0.04	0.18	0.11	0.02	0.11	0.04	0.04	0.18	0.12	0.06	0.11	0.11
s, saturation flow rate [veh/h]	5271	3612	2756	3514	5167	1543	3461	5131	2773	3478	3572	1838
c, Capacity [veh/h]	336	826	630	110	1014	303	211	2867	1549	259	2045	1053
d1, Uniform Delay [s]	68.68	54.17	50.20	71.61	54.31	50.54	69.24	17.91	16.58	68.14	15.37	15.38
k, delay calibration	0.11	0.13	0.13	0.11	0.13	0.13	0.11	0.50	0.50	0.11	0.50	0.50
l, Upstream Filtering Factor	1.00	1.00	1.00	1.00	1.00	1.00	1.00	1.00	1.00	1.00	1.00	1.00
d2, Incremental Delay [s]	2.24	1.86	0.74	3.99	0.56	0.41	4.71	0.31	0.32	4.63	0.20	0.40
d3, Initial Queue Delay [s]	0.00	0.00	0.00	0.00	0.00	0.00	0.00	0.00	0.00	0.00	0.00	0.00
Rp, platoon ratio	1.00	1.00	1.00	1.00	1.00	1.00	1.00	1.00	1.00	1.00	1.00	1.00
PF, progression factor	1.00	1.00	1.00	1.00	1.00	1.00	1.00	1.00	1.00	1.00	1.00	1.00

**Lane Group Results**

X, volume / capacity	0.66	0.77	0.50	0.54	0.55	0.21	0.73	0.33	0.22	0.76	0.19	0.19
d, Delay for Lane Group [s/veh]	70.92	56.03	50.93	75.61	54.86	50.95	73.95	18.21	16.90	72.77	15.57	15.78
Lane Group LOS	E	E	D	E	D	D	E	B	B	E	B	B
Critical Lane Group	No	Yes	No	Yes	No	No	No	Yes	No	Yes	No	No
50th-Percentile Queue Length [veh/ln]	2.86	11.40	5.19	1.18	6.34	2.03	3.00	5.89	2.94	3.87	3.18	3.35
50th-Percentile Queue Length [ft/ln]	71.44	285.05	129.78	29.48	158.50	50.76	75.10	147.13	73.38	96.65	79.39	83.66
95th-Percentile Queue Length [veh/ln]	5.14	16.94	8.93	2.12	10.47	3.66	5.41	9.86	5.28	6.96	5.72	6.02
95th-Percentile Queue Length [ft/ln]	128.58	423.49	223.20	53.07	261.74	91.38	135.18	246.60	132.08	173.96	142.90	150.59



**Movement, Approach, & Intersection Results**

d_M, Delay for Movement [s/veh]	70.92	56.03	50.93	75.61	54.86	50.95	73.95	18.21	16.90	72.77	15.64	15.78
Movement LOS	E	E	D	E	D	D	E	B	B	E	B	B
d_A, Approach Delay [s/veh]	57.50			56.31			23.85			30.11		
Approach LOS	E			E			C			C		
d_I, Intersection Delay [s/veh]	40.16											
Intersection LOS	D											
Intersection V/C	0.471											

**Emissions**

Vehicle Miles Traveled [mph]	22.63	64.44	31.86	6.87	64.48	7.33	17.49	108.01	38.40	174.11	338.37	175.16
Stops [stops/h]	205.68	547.14	249.11	56.59	456.37	48.72	144.15	423.63	140.85	185.51	152.38	80.30
Fuel consumption [US gal/h]	5.63	13.81	6.34	1.60	12.07	1.30	4.34	11.53	3.91	10.99	14.84	7.70
CO [g/h]	393.34	965.35	443.33	111.49	844.00	90.80	303.69	806.19	273.66	768.24	1037.10	538.41
NOx [g/h]	76.53	187.82	86.26	21.69	164.21	17.67	59.09	156.85	53.24	149.47	201.78	104.76
VOC [g/h]	91.16	223.73	102.75	25.84	195.61	21.04	70.38	186.84	63.42	178.05	240.36	124.78

**Other Modes**

g_Walk,mi, Effective Walk Time [s]	8.0			8.0			8.0			8.0		
M_corner, Corner Circulation Area [ft <sup>2</sup> /ped]	0.00			0.00			0.00			0.00		
M_CW, Crosswalk Circulation Area [ft <sup>2</sup> /ped]	243.36			1167.32			1473.17			133.26		
d_p, Pedestrian Delay [s]	67.23			67.23			67.23			67.23		
I_p,int, Pedestrian LOS Score for Intersectio	3.250			2.963			3.289			3.093		
Crosswalk LOS	C			C			C			C		
s_b, Saturation Flow Rate of the bicycle lane	2000			2000			2000			2000		
c_b, Capacity of the bicycle lane [bicycles/h]	653			605			733			800		
d_b, Bicycle Delay [s]	34.04			36.49			30.16			27.03		
I_b,int, Bicycle LOS Score for Intersection	2.527			1.931			2.348			1.990		
Bicycle LOS	B			A			B			A		

**Sequence**

Ring 1	1	2	3	4	-	-	-	-	-	-	-	-	-	-	-
Ring 2	5	6	7	8	-	-	-	-	-	-	-	-	-	-	-
Ring 3	-	-	-	-	-	-	-	-	-	-	-	-	-	-	-
Ring 4	-	-	-	-	-	-	-	-	-	-	-	-	-	-	-

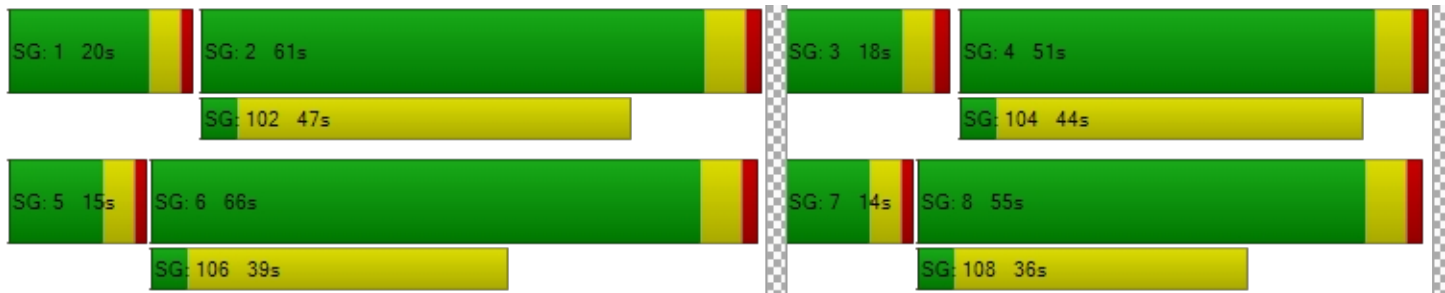

**Intersection Level Of Service Report**  
**Intersection 2: Tassajara Road & Central Parkway**

Control Type:	Signalized	Delay (sec / veh):	32.0
Analysis Method:	HCM 7th Edition	Level Of Service:	C
Analysis Period:	15 minutes	Volume to Capacity (v/c):	0.552

**Intersection Setup**

Name	Tassajara Road			Tassajara Road			Central Parkway			Central Parkway		
Approach	Northbound			Southbound			Eastbound			Westbound		
Lane Configuration	⇐   ⇐			⇐   ⇐			⇐  ⇐			⇐  ⇐		
Turning Movement	Left	Thru	Right	Left	Thru	Right	Left	Thru	Right	Left	Thru	Right
Lane Width [ft]	12.00	12.00	12.00	12.00	12.00	12.00	12.00	12.00	12.00	12.00	12.00	12.00
No. of Lanes in Entry Pocket	1	0	1	1	0	1	1	0	1	2	0	0
Entry Pocket Length [ft]	325.00	100.00	325.00	300.00	100.00	215.00	225.00	100.00	225.00	300.00	100.00	100.00
No. of Lanes in Exit Pocket	0	0	0	0	0	0	0	0	0	0	0	0
Exit Pocket Length [ft]	0.00	0.00	0.00	0.00	0.00	0.00	0.00	0.00	0.00	0.00	0.00	0.00
Speed [mph]	40.00			40.00			35.00			35.00		
Grade [%]	0.00			0.00			0.00			0.00		
Curb Present	Yes			Yes			Yes			Yes		
Crosswalk	Yes			Yes			Yes			Yes		



**Volumes**

Name	Tassajara Road			Tassajara Road			Central Parkway			Central Parkway		
Base Volume Input [veh/h]	68	913	182	23	863	42	69	230	129	168	104	23
Base Volume Adjustment Factor	1.0000	1.0000	1.0000	1.0000	1.0000	1.0000	1.0000	1.0000	1.0000	1.0000	1.0000	1.0000
Heavy Vehicles Percentage [%]	0.00	0.10	0.00	0.00	0.60	0.00	0.00	0.00	0.00	0.00	0.00	0.00
Proportion of CAVs [%]	0.00											
Growth Factor	1.0000	1.0000	1.0000	1.0000	1.0000	1.0000	1.0000	1.0000	1.0000	1.0000	1.0000	1.0000
In-Process Volume [veh/h]	0	0	0	0	0	0	0	0	0	0	0	0
Site-Generated Trips [veh/h]	0	0	0	0	0	0	0	0	0	0	0	0
Diverted Trips [veh/h]	0	0	0	0	0	0	0	0	0	0	0	0
Pass-by Trips [veh/h]	0	0	0	0	0	0	0	0	0	0	0	0
Existing Site Adjustment Volume [veh/h]	0	0	0	0	0	0	0	0	0	0	0	0
Other Volume [veh/h]	0	0	0	0	0	0	0	0	0	0	0	0
Right Turn on Red Volume [veh/h]	0	0	0	0	0	0	0	0	0	0	0	0
Total Hourly Volume [veh/h]	68	913	182	23	863	42	69	230	129	168	104	23
Peak Hour Factor	0.8900	0.8900	0.8900	0.8900	0.8900	0.8900	0.8900	0.8900	0.8900	0.8900	0.8900	0.8900
Other Adjustment Factor	1.0000	1.0000	1.0000	1.0000	1.0000	1.0000	1.0000	1.0000	1.0000	1.0000	1.0000	1.0000
Total 15-Minute Volume [veh/h]	19	256	51	6	242	12	19	65	36	47	29	6
Total Analysis Volume [veh/h]	76	1026	204	26	970	47	78	258	145	189	117	26
Presence of On-Street Parking	No		No	No		No	No		No	No		No
On-Street Parking Maneuver Rate [/h]	0	0	0	0	0	0	0	0	0	0	0	0
Local Bus Stopping Rate [/h]	0	0	0	0	0	0	0	0	0	0	0	0
v_do, Outbound Pedestrian Volume crossing	2			1			2			0		
v_di, Inbound Pedestrian Volume crossing m	2			0			2			1		
v_co, Outbound Pedestrian Volume crossing	0			4			5			0		
v_ci, Inbound Pedestrian Volume crossing mi	0			5			4			0		
v_ab, Corner Pedestrian Volume [ped/h]	0			0			0			0		
Bicycle Volume [bicycles/h]	1			1			0			0		



**Intersection Settings**

Located in CBD	No
Signal Coordination Group	-
Cycle Length [s]	130
Active Pattern	Pattern 1
Coordination Type	Time of Day Pattern Coordinated
Actuation Type	Fully actuated
Offset [s]	124.0
Offset Reference	Lead Green - Beginning of First Green
Permissive Mode	SingleBand
Lost time [s]	12.00

**Phasing & Timing (Basic)**

Control Type	Protecte	Permiss	Permiss	Protecte	Permiss	Permiss	Protecte	Permiss	Permiss	Protecte	Permiss	Permiss
Signal Group	3	8	0	7	4	0	5	2	0	1	6	0
Auxiliary Signal Groups												
Maximum Green [s]	20	40	0	20	40	0	20	20	0	20	20	0
Amber [s]	3.5	4.3	0.0	3.5	4.3	0.0	3.5	4.1	0.0	3.5	4.1	0.0
All red [s]	1.0	1.0	0.0	1.0	1.0	0.0	1.0	1.0	0.0	1.0	1.0	0.0
Walk [s]	0	4	0	0	4	0	0	4	0	0	4	0
Pedestrian Clearance [s]	0	20	0	0	24	0	0	36	0	0	30	0
Delayed Vehicle Green [s]	0.0	0.0	0.0	0.0	0.0	0.0	0.0	0.0	0.0	0.0	0.0	0.0
Rest In Walk		No			No			No			No	
I1, Start-Up Lost Time [s]	2.0	2.0	0.0	2.0	2.0	0.0	2.0	2.0	0.0	2.0	2.0	0.0
I2, Clearance Lost Time [s]	2.5	3.3	0.0	2.5	3.3	0.0	2.5	3.1	0.0	2.5	3.1	0.0
Detector Location [ft]	0.0	0.0	0.0	0.0	0.0	0.0	0.0	0.0	0.0	0.0	0.0	0.0
Detector Length [ft]	20.0	20.0	0.0	20.0	20.0	0.0	20.0	20.0	0.0	20.0	20.0	0.0
I, Upstream Filtering Factor	1.00	1.00	1.00	1.00	1.00	1.00	1.00	1.00	1.00	1.00	1.00	1.00

**Phasing & Timing: Pattern 1**

Split [s]	18	48	0	18	48	0	18	45	0	19	46	0
Lead / Lag	Lead	-	-	Lead	-	-	Lead	-	-	Lead	-	-
Minimum Green [s]	13	12	0	13	12	0	13	13	0	14	13	0
Vehicle Extension [s]	2.5	4.0	0.0	2.5	4.0	0.0	2.5	2.5	0.0	2.5	2.5	0.0
Minimum Recall	No	Yes		No	Yes		No	No		No	No	
Maximum Recall	No	No		No	No		No	No		No	No	
Pedestrian Recall	No	No		No	No		No	No		No	No	

**Exclusive Pedestrian Phase**

Pedestrian Signal Group	0
Pedestrian Walk [s]	0
Pedestrian Clearance [s]	0



**Lane Group Calculations**

Lane Group	L	C	R	L	C	R	L	C	R	L	C
C, Cycle Length [s]	130	130	130	130	130	130	130	130	130	130	130
L, Total Lost Time per Cycle [s]	4.50	5.30	5.30	4.50	5.30	5.30	4.50	5.10	5.10	4.50	5.10
l1_p, Permitted Start-Up Lost Time [s]	0.00	0.00	0.00	0.00	0.00	0.00	0.00	0.00	0.00	0.00	0.00
l2, Clearance Lost Time [s]	2.50	3.30	3.30	2.50	3.30	3.30	2.50	3.10	3.10	2.50	3.10
g_i, Effective Green Time [s]	12	67	67	8	63	63	12	21	21	14	23
g / C, Green / Cycle	0.09	0.52	0.52	0.06	0.49	0.49	0.09	0.16	0.16	0.11	0.18
(v / s)_i Volume / Saturation Flow Rate	0.04	0.28	0.13	0.01	0.27	0.03	0.04	0.14	0.09	0.05	0.08
s, saturation flow rate [veh/h]	1810	3615	1582	1810	3600	1567	1810	1900	1603	3514	1840
c, Capacity [veh/h]	170	1871	818	111	1746	760	171	311	262	380	326
d1, Uniform Delay [s]	55.65	21.12	17.31	58.05	23.58	17.75	55.66	52.58	49.92	54.62	47.68
k, delay calibration	0.08	0.50	0.50	0.08	0.50	0.50	0.08	0.08	0.08	0.08	0.08
l, Upstream Filtering Factor	1.00	1.00	1.00	1.00	1.00	1.00	1.00	1.00	1.00	1.00	1.00
d2, Incremental Delay [s]	1.36	1.16	0.73	0.79	1.28	0.16	1.41	4.28	1.35	0.75	0.69
d3, Initial Queue Delay [s]	0.00	0.00	0.00	0.00	0.00	0.00	0.00	0.00	0.00	0.00	0.00
Rp, platoon ratio	1.00	1.00	1.00	1.00	1.00	1.00	1.00	1.00	1.00	1.00	1.00
PF, progression factor	1.00	1.00	1.00	1.00	1.00	1.00	1.00	1.00	1.00	1.00	1.00

**Lane Group Results**

X, volume / capacity	0.45	0.55	0.25	0.23	0.56	0.06	0.46	0.83	0.55	0.50	0.44
d, Delay for Lane Group [s/veh]	57.02	22.28	18.04	58.83	24.86	17.90	57.07	56.86	51.27	55.37	48.37
Lane Group LOS	E	C	B	E	C	B	E	E	D	E	D
Critical Lane Group	Yes	No	No	No	Yes	No	No	Yes	No	Yes	No
50th-Percentile Queue Length [veh/ln]	2.39	10.38	3.45	0.83	10.43	0.77	2.48	8.45	4.41	2.95	4.18
50th-Percentile Queue Length [ft/ln]	59.87	259.45	86.25	20.76	260.74	19.27	61.96	211.31	110.28	73.64	104.61
95th-Percentile Queue Length [veh/ln]	4.31	15.66	6.21	1.49	15.73	1.39	4.46	13.22	7.86	5.30	7.53
95th-Percentile Queue Length [ft/ln]	107.77	391.53	155.25	37.36	393.15	34.69	111.54	330.51	196.40	132.55	188.30





**Movement, Approach, & Intersection Results**

d_M, Delay for Movement [s/veh]	57.02	22.28	18.04	58.83	24.86	17.90	57.07	56.86	51.27	55.37	48.37	48.37
Movement LOS	E	C	B	E	C	B	E	E	D	E	D	D
d_A, Approach Delay [s/veh]	23.64			25.40			55.21			52.36		
Approach LOS	C			C			E			D		
d_I, Intersection Delay [s/veh]	32.04											
Intersection LOS	C											
Intersection V/C	0.552											

**Emissions**

Vehicle Miles Traveled [mph]	21.92	295.88	58.83	4.95	184.52	8.94	10.26	33.95	19.08	25.63	19.39
Stops [stops/h]	66.34	574.96	95.57	23.00	577.83	21.35	68.66	234.14	122.20	163.20	115.91
Fuel consumption [US gal/h]	2.32	20.90	3.80	0.71	17.19	0.70	1.81	6.04	3.16	4.33	3.02
CO [g/h]	162.06	1460.80	265.27	49.93	1201.84	49.02	126.76	422.19	220.81	302.93	210.99
NOx [g/h]	31.53	284.22	51.61	9.72	233.84	9.54	24.66	82.14	42.96	58.94	41.05
VOC [g/h]	37.56	338.56	61.48	11.57	278.54	11.36	29.38	97.85	51.18	70.21	48.90

**Other Modes**

g_Walk,mi, Effective Walk Time [s]	8.0			8.0			8.0			8.0		
M_corner, Corner Circulation Area [ft <sup>2</sup> /ped]	0.00			0.00			0.00			0.00		
M_CW, Crosswalk Circulation Area [ft <sup>2</sup> /ped]	1064.33			5332.37			497.83			0.00		
d_p, Pedestrian Delay [s]	57.23			57.23			57.23			57.23		
I_p,int, Pedestrian LOS Score for Intersectio	3.169			2.943			2.356			2.384		
Crosswalk LOS	C			C			B			B		
s_b, Saturation Flow Rate of the bicycle lane	2000			2000			2000			2000		
c_b, Capacity of the bicycle lane [bicycles/h]	657			657			614			629		
d_b, Bicycle Delay [s]	29.31			29.31			31.20			30.52		
I_b,int, Bicycle LOS Score for Intersection	2.637			2.420			2.353			2.107		
Bicycle LOS	B			B			B			B		

**Sequence**

Ring 1	1	2	3	4	-	-	-	-	-	-	-	-	-	-	-
Ring 2	5	6	7	8	-	-	-	-	-	-	-	-	-	-	-
Ring 3	-	-	-	-	-	-	-	-	-	-	-	-	-	-	-
Ring 4	-	-	-	-	-	-	-	-	-	-	-	-	-	-	-



**Intersection Level Of Service Report**  
**Intersection 3: Tassajara Road & Dublin Boulevard**

Control Type:	Signalized	Delay (sec / veh):	53.0
Analysis Method:	HCM 7th Edition	Level Of Service:	D
Analysis Period:	15 minutes	Volume to Capacity (v/c):	0.845

**Intersection Setup**

Name	Tassajara Road			Tassajara Road			Dublin Boulevard			Dublin Boulevard		
Approach	Northbound			Southbound			Eastbound			Westbound		
Lane Configuration	[Diagram]			[Diagram]			[Diagram]			[Diagram]		
Turning Movement	Left	Thru	Right	Left	Thru	Right	Left	Thru	Right	Left	Thru	Right
Lane Width [ft]	12.00	12.00	12.00	12.00	12.00	12.00	12.00	12.00	12.00	12.00	12.00	12.00
No. of Lanes in Entry Pocket	3	0	1	2	0	2	2	0	2	3	0	0
Entry Pocket Length [ft]	380.00	100.00	250.00	295.00	100.00	290.00	265.00	100.00	330.00	395.00	100.00	100.00
No. of Lanes in Exit Pocket	0	0	1	0	0	0	0	0	0	0	0	0
Exit Pocket Length [ft]	0.00	0.00	49.21	0.00	0.00	0.00	0.00	0.00	0.00	0.00	0.00	0.00
Speed [mph]	30.00			40.00			40.00			40.00		
Grade [%]	0.00			0.00			0.00			0.00		
Curb Present	Yes			Yes			Yes			Yes		
Crosswalk	Yes			Yes			Yes			Yes		



**Volumes**

Name	Tassajara Road			Tassajara Road			Dublin Boulevard			Dublin Boulevard		
Base Volume Input [veh/h]	306	781	607	144	958	125	259	593	469	526	351	44
Base Volume Adjustment Factor	1.0000	1.0000	1.0000	1.0000	1.0000	1.0000	1.0000	1.0000	1.0000	1.0000	1.0000	1.0000
Heavy Vehicles Percentage [%]	0.70	0.00	0.00	1.20	0.40	0.00	0.40	0.80	13.00	0.20	1.30	0.00
Proportion of CAVs [%]	0.00											
Growth Factor	1.0000	1.0000	1.0000	1.0000	1.0000	1.0000	1.0000	1.0000	1.0000	1.0000	1.0000	1.0000
In-Process Volume [veh/h]	0	0	0	0	0	0	0	0	0	0	0	0
Site-Generated Trips [veh/h]	0	0	0	0	0	0	0	0	0	0	0	0
Diverted Trips [veh/h]	0	0	0	0	0	0	0	0	0	0	0	0
Pass-by Trips [veh/h]	0	0	0	0	0	0	0	0	0	0	0	0
Existing Site Adjustment Volume [veh/h]	0	0	0	0	0	0	0	0	0	0	0	0
Other Volume [veh/h]	0	0	0	0	0	0	0	0	0	0	0	0
Right Turn on Red Volume [veh/h]	0	0	0	0	0	0	0	0	0	0	0	0
Total Hourly Volume [veh/h]	306	781	607	144	958	125	259	593	469	526	351	44
Peak Hour Factor	0.9100	0.9100	0.9100	0.9100	0.9100	0.9100	0.9100	0.9100	0.9100	0.9100	0.9100	0.9100
Other Adjustment Factor	1.0000	1.0000	1.0000	1.0000	1.0000	1.0000	1.0000	1.0000	1.0000	1.0000	1.0000	1.0000
Total 15-Minute Volume [veh/h]	84	215	167	40	263	34	71	163	129	145	96	12
Total Analysis Volume [veh/h]	336	858	667	158	1053	137	285	652	515	578	386	48
Presence of On-Street Parking	No		No	No		No	No		No	No		No
On-Street Parking Maneuver Rate [/h]	0	0	0	0	0	0	0	0	0	0	0	0
Local Bus Stopping Rate [/h]	0	0	0	0	0	0	0	0	0	0	0	0
v_do, Outbound Pedestrian Volume crossing	0			2			3			0		
v_di, Inbound Pedestrian Volume crossing m	0			3			2			0		
v_co, Outbound Pedestrian Volume crossing	0			4			0			3		
v_ci, Inbound Pedestrian Volume crossing mi	0			3			0			4		
v_ab, Corner Pedestrian Volume [ped/h]	0			0			0			0		
Bicycle Volume [bicycles/h]	1			0			1			0		



**Intersection Settings**

Located in CBD	No
Signal Coordination Group	-
Cycle Length [s]	90
Active Pattern	Free Running (No Pattern)
Coordination Type	<i>Free Running</i>
Actuation Type	<i>Fully actuated</i>
Offset [s]	0.0
Offset Reference	Lead Green - Beginning of First Green
Permissive Mode	SingleBand
Lost time [s]	12.00

**Phasing & Timing (Basic)**

Control Type	Protecte	Permiss	Permiss	Protecte	Permiss	Permiss	Protecte	Permiss	Overlap	Protecte	Permiss	Permiss
Signal Group	3	8	0	7	4	0	5	2	2	1	6	0
Auxiliary Signal Groups									2,3			
Maximum Green [s]	20	35	0	20	35	0	20	35	35	20	35	0
Amber [s]	3.5	4.5	0.0	3.5	4.5	0.0	3.5	4.5	4.5	3.5	4.5	0.0
All red [s]	1.5	1.5	0.0	1.5	1.5	0.0	1.5	1.5	1.5	1.5	1.5	0.0
Walk [s]	0	4	0	0	4	0	0	0	0	0	4	0
Pedestrian Clearance [s]	0	29	0	0	42	0	0	0	0	0	42	0
Delayed Vehicle Green [s]	0.0	0.0	0.0	0.0	0.0	0.0	0.0	0.0	0.0	0.0	0.0	0.0
Rest In Walk		No			No			No			No	
I1, Start-Up Lost Time [s]	2.0	2.0	0.0	2.0	2.0	0.0	2.0	2.0	2.0	2.0	2.0	0.0
I2, Clearance Lost Time [s]	2.0	2.0	0.0	2.0	2.0	0.0	2.0	2.0	2.0	2.0	2.0	0.0
Detector Location [ft]	0.0	0.0	0.0	0.0	0.0	0.0	0.0	0.0	0.0	0.0	0.0	0.0
Detector Length [ft]	20.0	20.0	0.0	20.0	20.0	0.0	20.0	20.0	20.0	20.0	20.0	0.0
I, Upstream Filtering Factor	1.00	1.00	1.00	1.00	1.00	1.00	1.00	1.00	1.00	1.00	1.00	1.00

**Phasing & Timing: Free Running (No Pattern)**

Split [s]	0	0	0	0	0	0	0	0	0	0	0	0
Lead / Lag	Lead	-	-	Lead	-	-	Lead	-	-	Lead	-	-
Minimum Green [s]	16	15	0	15	15	0	16	16	16	16	15	0
Vehicle Extension [s]	2.0	4.0	0.0	2.0	4.0	0.0	2.0	3.0	3.0	2.0	3.0	0.0
Minimum Recall	No	Yes		No	Yes		No	No	No	No	No	
Maximum Recall	No	No		No	No		No	No	No	No	No	
Pedestrian Recall	No	No		No	No		No	No	No	No	No	

**Exclusive Pedestrian Phase**

Pedestrian Signal Group	0
Pedestrian Walk [s]	0
Pedestrian Clearance [s]	0



**Lane Group Calculations**

Lane Group	L	C	R	L	C	R	L	C	R	L	C	C
C, Cycle Length [s]	113	113	113	113	113	113	113	113	113	113	113	113
L, Total Lost Time per Cycle [s]	4.00	4.00	4.00	4.00	4.00	4.00	4.00	4.00	4.00	4.00	4.00	4.00
l1_p, Permitted Start-Up Lost Time [s]	0.00	0.00	0.00	0.00	0.00	0.00	0.00	0.00	0.00	0.00	0.00	0.00
l2, Clearance Lost Time [s]	2.00	2.00	2.00	2.00	2.00	2.00	2.00	2.00	0.00	2.00	2.00	2.00
g_i, Effective Green Time [s]	20	37	37	16	33	33	17	27	50	17	27	27
g / C, Green / Cycle	0.17	0.33	0.33	0.14	0.30	0.30	0.15	0.24	0.45	0.15	0.24	0.24
(v / s)_i Volume / Saturation Flow Rate	0.06	0.24	0.42	0.05	0.15	0.05	0.08	0.18	0.20	0.11	0.12	0.12
s, saturation flow rate [veh/h]	5242	3618	1595	3481	6879	2844	3503	3595	2547	5263	1880	1804
c, Capacity [veh/h]	914	1188	524	492	2032	840	529	853	1115	795	446	428
d1, Uniform Delay [s]	41.04	33.31	37.60	43.52	33.03	29.38	44.20	40.04	22.25	45.61	37.14	37.15
k, delay calibration	0.04	0.15	0.50	0.04	0.15	0.15	0.04	0.11	0.11	0.04	0.11	0.11
l, Upstream Filtering Factor	1.00	1.00	1.00	1.00	1.00	1.00	1.00	1.00	1.00	1.00	1.00	1.00
d2, Incremental Delay [s]	0.09	1.20	137.53	0.14	0.29	0.13	0.32	1.46	0.30	0.48	0.85	0.89
d3, Initial Queue Delay [s]	0.00	0.00	0.00	0.00	0.00	0.00	0.00	0.00	0.00	0.00	0.00	0.00
Rp, platoon ratio	1.00	1.00	1.00	1.00	1.00	1.00	1.00	1.00	1.00	1.00	1.00	1.00
PF, progression factor	1.00	1.00	1.00	1.00	1.00	1.00	1.00	1.00	1.00	1.00	1.00	1.00

**Lane Group Results**

X, volume / capacity	0.37	0.72	1.27	0.32	0.52	0.16	0.54	0.76	0.46	0.73	0.50	0.50
d, Delay for Lane Group [s/veh]	41.13	34.51	175.13	43.66	33.32	29.51	44.52	41.50	22.54	46.09	37.99	38.04
Lane Group LOS	D	C	F	D	C	C	D	D	C	D	D	D
Critical Lane Group	No	No	Yes	Yes	No	No	No	Yes	No	Yes	No	No
50th-Percentile Queue Length [veh/ln]	2.75	10.39	34.04	1.96	5.85	1.36	3.62	8.35	4.64	5.06	5.25	5.06
50th-Percentile Queue Length [ft/ln]	68.83	259.63	851.02	48.90	146.30	34.00	90.61	208.69	115.88	126.49	131.31	126.44
95th-Percentile Queue Length [veh/ln]	4.96	15.67	50.33	3.52	9.82	2.45	6.52	13.09	8.17	8.75	9.01	8.75
95th-Percentile Queue Length [ft/ln]	123.89	391.76	1258.15	88.02	245.48	61.20	163.10	327.15	204.15	218.72	225.27	218.64



**Movement, Approach, & Intersection Results**

d_M, Delay for Movement [s/veh]	41.13	34.51	175.13	43.66	33.32	29.51	44.52	41.50	22.54	46.09	38.01	38.04
Movement LOS	D	C	F	D	C	C	D	D	C	D	D	D
d_A, Approach Delay [s/veh]	86.11			34.15			35.37			42.63		
Approach LOS	F			C			D			D		
d_I, Intersection Delay [s/veh]	53.02											
Intersection LOS	D											
Intersection V/C	0.845											

**Emissions**

Vehicle Miles Traveled [mph]	68.92	176.00	136.82	45.57	303.67	39.51	250.61	573.32	452.85	695.42	266.17	256.00
Stops [stops/h]	264.07	664.11	1088.39	125.08	748.43	86.97	231.77	533.80	296.41	485.32	167.93	161.71
Fuel consumption [US gal/h]	7.11	16.94	35.41	4.26	25.37	3.09	13.84	31.29	21.50	35.10	12.89	12.41
CO [g/h]	496.86	1184.10	2475.35	298.08	1773.37	216.15	967.10	2186.87	1502.56	2453.41	901.32	867.15
NOx [g/h]	96.67	230.38	481.61	58.00	345.03	42.05	188.16	425.49	292.34	477.34	175.36	168.72
VOC [g/h]	115.15	274.43	573.69	69.08	411.00	50.09	224.14	506.83	348.23	568.60	208.89	200.97

**Other Modes**

g_Walk,mi, Effective Walk Time [s]	-6.0		8.0		8.0		8.0	
M_corner, Corner Circulation Area [ft <sup>2</sup> /ped]	0.00		0.00		0.00		0.00	
M_CW, Crosswalk Circulation Area [ft <sup>2</sup> /ped]	0.00		0.00		0.00		0.00	
d_p, Pedestrian Delay [s]	62.46		48.58		48.58		48.58	
I_p,int, Pedestrian LOS Score for Intersectio	3.380		3.310		3.196		3.143	
Crosswalk LOS	C		C		C		C	
s_b, Saturation Flow Rate of the bicycle lane	2000		2000		2000		2000	
c_b, Capacity of the bicycle lane [bicycles/h]	622		622		622		622	
d_b, Bicycle Delay [s]	26.75		26.74		26.75		26.74	
I_b,int, Bicycle LOS Score for Intersection	3.095		2.116		2.758		2.395	
Bicycle LOS	C		B		C		B	

**Sequence**

Ring 1	1	2	3	4	-	-	-	-	-	-	-	-	-	-	-
Ring 2	5	6	7	8	-	-	-	-	-	-	-	-	-	-	-
Ring 3	-	-	-	-	-	-	-	-	-	-	-	-	-	-	-
Ring 4	-	-	-	-	-	-	-	-	-	-	-	-	-	-	-



**Intersection Level Of Service Report**  
**Intersection 4: Tassajara Road & I-580 WB Ramps**

Control Type:	Signalized	Delay (sec / veh):	11.7
Analysis Method:	HCM 7th Edition	Level Of Service:	B
Analysis Period:	15 minutes	Volume to Capacity (v/c):	0.680

**Intersection Setup**

Name	Tassajara Road		Tassajara Road		I-580 WB Ramps	
Approach	Northbound		Southbound		Westbound	
Lane Configuration	↑↑		↑↑↑		↔↔↔↔	
Turning Movement	Thru	Right	Left	Thru	Left	Right
Lane Width [ft]	12.00	12.00	12.00	12.00	12.00	12.00
No. of Lanes in Entry Pocket	0	0	0	0	1	1
Entry Pocket Length [ft]	100.00	100.00	100.00	100.00	100.00	100.00
No. of Lanes in Exit Pocket	0	1	0	0	0	0
Exit Pocket Length [ft]	0.00	49.21	0.00	0.00	0.00	0.00
Speed [mph]	30.00		30.00		30.00	
Grade [%]	0.00		0.00		0.00	
Curb Present	No		No		No	
Crosswalk	Yes		Yes		Yes	



**Volumes**

Name	Tassajara Road		Tassajara Road		I-580 WB Ramps	
Base Volume Input [veh/h]	1620	0	0	1419	495	250
Base Volume Adjustment Factor	1.0000	1.0000	1.0000	1.0000	1.0000	1.0000
Heavy Vehicles Percentage [%]	0.40	2.00	2.00	0.80	0.40	1.70
Proportion of CAVs [%]	0.00					
Growth Factor	1.0000	1.0000	1.0000	1.0000	1.0000	1.0000
In-Process Volume [veh/h]	0	0	0	0	0	0
Site-Generated Trips [veh/h]	0	0	0	0	0	0
Diverted Trips [veh/h]	0	0	0	0	0	0
Pass-by Trips [veh/h]	0	0	0	0	0	0
Existing Site Adjustment Volume [veh/h]	0	0	0	0	0	0
Other Volume [veh/h]	0	0	0	0	0	0
Right Turn on Red Volume [veh/h]	0	0	0	0	0	0
Total Hourly Volume [veh/h]	1620	0	0	1419	495	250
Peak Hour Factor	0.9600	1.0000	1.0000	0.9600	0.9600	0.9600
Other Adjustment Factor	1.0000	1.0000	1.0000	1.0000	1.0000	1.0000
Total 15-Minute Volume [veh/h]	422	0	0	370	129	65
Total Analysis Volume [veh/h]	1688	0	0	1478	516	260
Presence of On-Street Parking	No	No	No	No	No	No
On-Street Parking Maneuver Rate [/h]	0	0	0	0	0	0
Local Bus Stopping Rate [/h]	0	0	0	0	0	0
v_do, Outbound Pedestrian Volume crossing	0		0		0	
v_di, Inbound Pedestrian Volume crossing m	0		0		0	
v_co, Outbound Pedestrian Volume crossing	0		0		0	
v_ci, Inbound Pedestrian Volume crossing mi	0		0		0	
v_ab, Corner Pedestrian Volume [ped/h]	0		0		0	
Bicycle Volume [bicycles/h]	1		0		0	





**Intersection Settings**

Located in CBD	No
Signal Coordination Group	-
Cycle Length [s]	60
Active Pattern	Pattern 1
Coordination Type	Time of Day Pattern Coordinated
Actuation Type	Fully actuated
Offset [s]	29.0
Offset Reference	Beginning of First Yellow
Permissive Mode	SingleBand
Lost time [s]	6.00

**Phasing & Timing (Basic)**

Control Type	Permissive	Permissive	Permissive	Permissive	Permissive	Permissive
Signal Group	6	0	0	2	4	0
Auxiliary Signal Groups						
Maximum Green [s]	40	0	0	40	20	0
Amber [s]	4.9	0.0	0.0	4.9	4.4	0.0
All red [s]	1.0	0.0	0.0	1.0	1.0	0.0
Walk [s]	5	0	0	0	0	0
Pedestrian Clearance [s]	16	0	0	0	0	0
Delayed Vehicle Green [s]	0.0	0.0	0.0	0.0	0.0	0.0
Rest In Walk	No			No	No	
I1, Start-Up Lost Time [s]	2.0	0.0	0.0	2.0	2.0	0.0
I2, Clearance Lost Time [s]	3.9	0.0	0.0	3.9	3.4	0.0
Detector Location [ft]	0.0	0.0	0.0	0.0	0.0	0.0
Detector Length [ft]	20.0	0.0	0.0	20.0	20.0	0.0
I, Upstream Filtering Factor	1.00	1.00	1.00	1.00	1.00	1.00

**Phasing & Timing: Pattern 1**

Split [s]	36	0	0	36	24	0
Lead / Lag	-	-	-	-	Lead	-
Minimum Green [s]	7	0	0	7	4	0
Vehicle Extension [s]	3.0	0.0	0.0	3.0	2.0	0.0
Minimum Recall	No			No	No	
Maximum Recall	Yes			Yes	No	
Pedestrian Recall	Yes			No	No	

**Exclusive Pedestrian Phase**

Pedestrian Signal Group	0
Pedestrian Walk [s]	0
Pedestrian Clearance [s]	0



**Lane Group Calculations**

Lane Group	C	C	L	R
C, Cycle Length [s]	63	63	63	63
L, Total Lost Time per Cycle [s]	5.90	5.90	5.40	5.40
l1_p, Permitted Start-Up Lost Time [s]	0.00	0.00	0.00	0.00
l2, Clearance Lost Time [s]	3.90	3.90	3.40	3.40
g_i, Effective Green Time [s]	40	40	12	12
g / C, Green / Cycle	0.63	0.63	0.19	0.19
(v / s)_i Volume / Saturation Flow Rate	0.47	0.29	0.15	0.09
s, saturation flow rate [veh/h]	3606	5143	3503	2820
c, Capacity [veh/h]	2276	3247	667	537
d1, Uniform Delay [s]	8.10	6.04	24.35	22.88
k, delay calibration	0.50	0.50	0.04	0.04
l, Upstream Filtering Factor	1.00	1.00	1.00	1.00
d2, Incremental Delay [s]	2.23	0.46	0.73	0.25
d3, Initial Queue Delay [s]	0.00	0.00	0.00	0.00
Rp, platoon ratio	1.00	1.00	1.00	1.00
PF, progression factor	1.00	1.00	1.00	1.00

**Lane Group Results**

X, volume / capacity	0.74	0.46	0.77	0.48
d, Delay for Lane Group [s/veh]	10.32	6.51	25.09	23.13
Lane Group LOS	B	A	C	C
Critical Lane Group	Yes	No	Yes	No
50th-Percentile Queue Length [veh/ln]	6.40	2.62	3.51	1.65
50th-Percentile Queue Length [ft/ln]	160.08	65.56	87.68	41.16
95th-Percentile Queue Length [veh/ln]	10.55	4.72	6.31	2.96
95th-Percentile Queue Length [ft/ln]	263.83	118.01	157.82	74.09

**Movement, Approach, & Intersection Results**

d_M, Delay for Movement [s/veh]	10.32	0.00	0.00	6.51	25.09	23.13
Movement LOS	B			A	C	C
d_A, Approach Delay [s/veh]	10.32		6.51		24.43	
Approach LOS	B		A		C	
d_I, Intersection Delay [s/veh]	11.67					
Intersection LOS	B					
Intersection V/C	0.680					

**Emissions**

Vehicle Miles Traveled [mph]	284.24	303.18	41.73	21.03
Stops [stops/h]	728.17	447.32	398.81	187.23
Fuel consumption [US gal/h]	19.27	16.91	6.56	3.12
CO [g/h]	1347.04	1182.00	458.25	218.35
NOx [g/h]	262.09	229.98	89.16	42.48
VOC [g/h]	312.19	273.94	106.20	50.60

**Other Modes**

g_Walk,mi, Effective Walk Time [s]	18.6	18.6	9.0
M_corner, Corner Circulation Area [ft <sup>2</sup> /ped]	0.00	0.00	0.00
M_CW, Crosswalk Circulation Area [ft <sup>2</sup> /ped]	0.00	0.00	0.00
d_p, Pedestrian Delay [s]	15.79	15.79	23.30
I_p,int, Pedestrian LOS Score for Intersectio	2.986	2.936	2.435
Crosswalk LOS	C	C	B
s_b, Saturation Flow Rate of the bicycle lane	2000	2000	2000
c_b, Capacity of the bicycle lane [bicycles/h]	951	951	588
d_b, Bicycle Delay [s]	8.72	8.71	15.79
I_b,int, Bicycle LOS Score for Intersection	2.952	2.373	1.560
Bicycle LOS	C	B	A

**Sequence**

Ring 1	-	2	-	4	-	-	-	-	-	-	-	-	-	-	-	-
Ring 2	-	6	-	-	-	-	-	-	-	-	-	-	-	-	-	-
Ring 3	-	-	-	-	-	-	-	-	-	-	-	-	-	-	-	-
Ring 4	-	-	-	-	-	-	-	-	-	-	-	-	-	-	-	-



**Intersection Level Of Service Report**  
**Intersection 5: Santa Rita Rd & I-580 EB Ramps/Pimlico Dr**

Control Type:	Signalized	Delay (sec / veh):	35.2
Analysis Method:	HCM 7th Edition	Level Of Service:	D
Analysis Period:	15 minutes	Volume to Capacity (v/c):	0.852

**Intersection Setup**

Name	Santa Rita Road			Tassajara Road			I-580 EB Ramps			Pimlico Drive		
Approach	Northbound			Southbound			Eastbound			Westbound		
Lane Configuration	↑			↵			↵↑			↵↵↵↑		
Turning Movement	Left	Thru	Right	Left	Thru	Right	Left	Thru	Right	Left	Thru	Right
Lane Width [ft]	12.00	12.00	12.00	12.00	12.00	12.00	12.00	12.00	12.00	12.00	12.00	12.00
No. of Lanes in Entry Pocket	0	0	1	1	0	0	1	0	0	2	0	1
Entry Pocket Length [ft]	100.00	100.00	250.00	425.00	100.00	100.00	625.00	100.00	100.00	200.00	100.00	250.00
No. of Lanes in Exit Pocket	0	0	0	0	0	2	0	0	0	0	0	0
Exit Pocket Length [ft]	0.00	0.00	0.00	0.00	0.00	49.21	0.00	0.00	0.00	0.00	0.00	0.00
Speed [mph]	30.00			30.00			30.00			30.00		
Grade [%]	0.00			0.00			0.00			0.00		
Curb Present	No			No			No			No		
Crosswalk	Yes			No			Yes			Yes		



**Volumes**

Name	Santa Rita Road			Tassajara Road			I-580 EB Ramps			Pimlico Drive		
Base Volume Input [veh/h]	0	1839	85	262	1155	0	556	209	0	112	0	431
Base Volume Adjustment Factor	1.0000	1.0000	1.0000	1.0000	1.0000	1.0000	1.0000	1.0000	1.0000	1.0000	1.0000	1.0000
Heavy Vehicles Percentage [%]	2.00	0.30	1.20	0.40	0.40	2.00	1.20	0.50	2.00	0.00	2.00	0.00
Proportion of CAVs [%]	0.00											
Growth Factor	1.0000	1.0000	1.0000	1.0000	1.0000	1.0000	1.0000	1.0000	1.0000	1.0000	1.0000	1.0000
In-Process Volume [veh/h]	0	0	0	0	0	0	0	0	0	0	0	0
Site-Generated Trips [veh/h]	0	0	0	0	0	0	0	0	0	0	0	0
Diverted Trips [veh/h]	0	0	0	0	0	0	0	0	0	0	0	0
Pass-by Trips [veh/h]	0	0	0	0	0	0	0	0	0	0	0	0
Existing Site Adjustment Volume [veh/h]	0	0	0	0	0	0	0	0	0	0	0	0
Other Volume [veh/h]	0	0	0	0	0	0	0	0	0	0	0	0
Right Turn on Red Volume [veh/h]	0	0	0	0	0	0	0	0	0	0	0	0
Total Hourly Volume [veh/h]	0	1839	85	262	1155	0	556	209	0	112	0	431
Peak Hour Factor	1.0000	0.9600	0.9600	0.9600	0.9600	1.0000	0.9600	0.9600	1.0000	0.9600	1.0000	0.9600
Other Adjustment Factor	1.0000	1.0000	1.0000	1.0000	1.0000	1.0000	1.0000	1.0000	1.0000	1.0000	1.0000	1.0000
Total 15-Minute Volume [veh/h]	0	479	22	68	301	0	145	54	0	29	0	112
Total Analysis Volume [veh/h]	0	1916	89	273	1203	0	579	218	0	117	0	449
Presence of On-Street Parking	No		No	No		No	No		No	No		No
On-Street Parking Maneuver Rate [/h]	0	0	0	0	0	0	0	0	0	0	0	0
Local Bus Stopping Rate [/h]	0	0	0	0	0	0	0	0	0	0	0	0
v_do, Outbound Pedestrian Volume crossing	1			0			0			0		
v_di, Inbound Pedestrian Volume crossing m	0			0			1			0		
v_co, Outbound Pedestrian Volume crossing	0			2			3			1		
v_ci, Inbound Pedestrian Volume crossing mi	1			3			2			0		
v_ab, Corner Pedestrian Volume [ped/h]	0			0			0			0		
Bicycle Volume [bicycles/h]	1			0			0			0		



**Intersection Settings**

Located in CBD	No
Signal Coordination Group	-
Cycle Length [s]	120
Active Pattern	Pattern 1
Coordination Type	Time of Day Pattern Coordinated
Actuation Type	Fully actuated
Offset [s]	13.0
Offset Reference	Lead Green - Beginning of First Green
Permissive Mode	SingleBand
Lost time [s]	12.00

**Phasing & Timing (Basic)**

Control Type	Permiss	Permiss	Permiss	Protecte	Permiss	Permiss	Protecte	Permiss	Permiss	Permiss	Permiss	Overlap
Signal Group	0	6	0	5	2	0	3	8	0	7	0	4
Auxiliary Signal Groups												4,5
Maximum Green [s]	0	30	0	20	30	0	27	20	0	20	0	20
Amber [s]	0.0	4.4	0.0	3.0	4.4	0.0	4.4	4.4	0.0	3.5	0.0	3.5
All red [s]	0.0	1.0	0.0	1.0	1.0	0.0	1.0	1.0	0.0	1.0	0.0	1.0
Walk [s]	0	5	0	0	5	0	0	5	0	0	0	0
Pedestrian Clearance [s]	0	25	0	0	8	0	0	25	0	0	0	0
Delayed Vehicle Green [s]	0.0	0.0	0.0	0.0	0.0	0.0	0.0	0.0	0.0	0.0	0.0	0.0
Rest In Walk		No			No			No		No		
I1, Start-Up Lost Time [s]	0.0	2.0	0.0	2.0	2.0	0.0	2.0	2.0	0.0	2.0	0.0	2.0
I2, Clearance Lost Time [s]	0.0	3.4	0.0	2.0	3.4	0.0	3.4	3.4	0.0	2.5	0.0	2.5
Detector Location [ft]	0.0	0.0	0.0	0.0	0.0	0.0	0.0	0.0	0.0	0.0	0.0	0.0
Detector Length [ft]	0.0	0.0	0.0	0.0	0.0	0.0	0.0	0.0	0.0	0.0	0.0	0.0
I, Upstream Filtering Factor	1.00	1.00	1.00	1.00	1.00	1.00	1.00	1.00	1.00	1.00	1.00	1.00

**Phasing & Timing: Pattern 1**

Split [s]	0	40	0	28	68	0	32	36	0	16	0	20
Lead / Lag	-	-	-	Lead	-	-	Lead	-	-	Lead	-	-
Minimum Green [s]	0	7	0	5	7	0	5	5	0	5	0	5
Vehicle Extension [s]	0.0	3.0	0.0	3.0	3.0	0.0	3.0	2.0	0.0	3.0	0.0	2.0
Minimum Recall		No		No	No		No	No		No		No
Maximum Recall		Yes		No	Yes		No	No		No		No
Pedestrian Recall		No		No	Yes		No	No		No		No

**Exclusive Pedestrian Phase**

Pedestrian Signal Group	0
Pedestrian Walk [s]	0
Pedestrian Clearance [s]	0



**Lane Group Calculations**

Lane Group	C	C	L	C	L	C	L	R
C, Cycle Length [s]	120	120	120	120	120	120	120	120
L, Total Lost Time per Cycle [s]	5.40	5.40	4.00	5.40	5.40	5.40	4.50	4.00
l1_p, Permitted Start-Up Lost Time [s]	0.00	0.00	0.00	0.00	0.00	0.00	0.00	0.00
l2, Clearance Lost Time [s]	3.40	3.40	2.00	3.40	3.40	3.40	2.50	0.00
g_i, Effective Green Time [s]	50	50	20	74	22	24	6	32
g / C, Green / Cycle	0.42	0.42	0.17	0.62	0.19	0.20	0.05	0.27
(v / s)_i Volume / Saturation Flow Rate	0.34	0.27	0.15	0.33	0.17	0.12	0.03	0.16
s, saturation flow rate [veh/h]	4379	1830	1804	3606	3481	1892	3514	2859
c, Capacity [veh/h]	1838	768	298	2230	648	386	177	774
d1, Uniform Delay [s]	30.74	27.80	49.22	13.10	47.62	42.96	55.92	37.84
k, delay calibration	0.50	0.50	0.36	0.50	0.11	0.12	0.11	0.04
l, Upstream Filtering Factor	1.00	1.00	1.00	1.00	1.00	1.00	1.00	1.00
d2, Incremental Delay [s]	4.19	4.29	27.59	0.94	4.59	1.48	4.18	0.26
d3, Initial Queue Delay [s]	0.00	0.00	0.00	0.00	0.00	0.00	0.00	0.00
Rp, platoon ratio	1.00	1.00	1.00	1.00	1.00	1.00	1.00	1.00
PF, progression factor	1.00	1.00	1.00	1.00	1.00	1.00	1.00	1.00

**Lane Group Results**

X, volume / capacity	0.82	0.65	0.92	0.54	0.89	0.57	0.66	0.58
d, Delay for Lane Group [s/veh]	34.93	32.09	76.81	14.04	52.20	44.44	60.11	38.09
Lane Group LOS	C	C	E	B	D	D	E	D
Critical Lane Group	Yes	No	Yes	No	Yes	No	No	Yes
50th-Percentile Queue Length [veh/ln]	13.28	12.28	10.30	9.17	8.82	5.98	1.84	5.73
50th-Percentile Queue Length [ft/ln]	332.00	306.98	257.53	229.26	220.60	149.56	46.08	143.26
95th-Percentile Queue Length [veh/ln]	19.26	18.03	15.56	14.14	13.70	9.99	3.32	9.66
95th-Percentile Queue Length [ft/ln]	481.41	450.65	389.12	353.42	342.40	249.84	82.94	241.41

**Movement, Approach, & Intersection Results**

d_M, Delay for Movement [s/veh]	0.00	34.32	32.09	76.81	14.04	0.00	52.20	44.44	0.00	60.11	0.00	38.09
Movement LOS		C	C	E	B		D	D		E		D
d_A, Approach Delay [s/veh]	34.22			25.65			50.08			42.64		
Approach LOS	C			C			D			D		
d_I, Intersection Delay [s/veh]	35.20											
Intersection LOS	D											
Intersection V/C	0.852											

**Emissions**

Vehicle Miles Traveled [mph]	148.31	49.44	45.97	202.57	80.34	30.25	9.99	38.32
Stops [stops/h]	1195.77	368.54	309.18	550.48	529.70	179.55	110.64	343.98
Fuel consumption [US gal/h]	23.40	7.34	7.87	14.82	12.38	4.21	2.45	6.96
CO [g/h]	1635.75	513.36	549.92	1035.82	865.66	294.19	171.49	486.40
NOx [g/h]	318.26	99.88	106.99	201.53	168.43	57.24	33.37	94.64
VOC [g/h]	379.10	118.98	127.45	240.06	200.63	68.18	39.74	112.73

**Other Modes**

g_Walk,mi, Effective Walk Time [s]	9.0	0.0	9.0	9.0
M_corner, Corner Circulation Area [ft <sup>2</sup> /ped]	0.00	0.00	0.00	0.00
M_CW, Crosswalk Circulation Area [ft <sup>2</sup> /ped]	6543.07	0.00	0.00	0.00
d_p, Pedestrian Delay [s]	51.31	0.00	51.31	51.31
I_p,int, Pedestrian LOS Score for Intersectio	3.008	0.000	2.341	2.539
Crosswalk LOS	C	F	B	B
s_b, Saturation Flow Rate of the bicycle lane	2000	2000	2000	2000
c_b, Capacity of the bicycle lane [bicycles/h]	577	1044	510	192
d_b, Bicycle Delay [s]	30.38	13.71	33.28	49.02
I_b,int, Bicycle LOS Score for Intersection	2.387	2.777	2.875	1.560
Bicycle LOS	B	C	C	A

**Sequence**

Ring 1	-	2	3	4	-	-	-	-	-	-	-	-	-	-	-
Ring 2	5	6	7	8	-	-	-	-	-	-	-	-	-	-	-
Ring 3	-	-	-	-	-	-	-	-	-	-	-	-	-	-	-
Ring 4	-	-	-	-	-	-	-	-	-	-	-	-	-	-	-

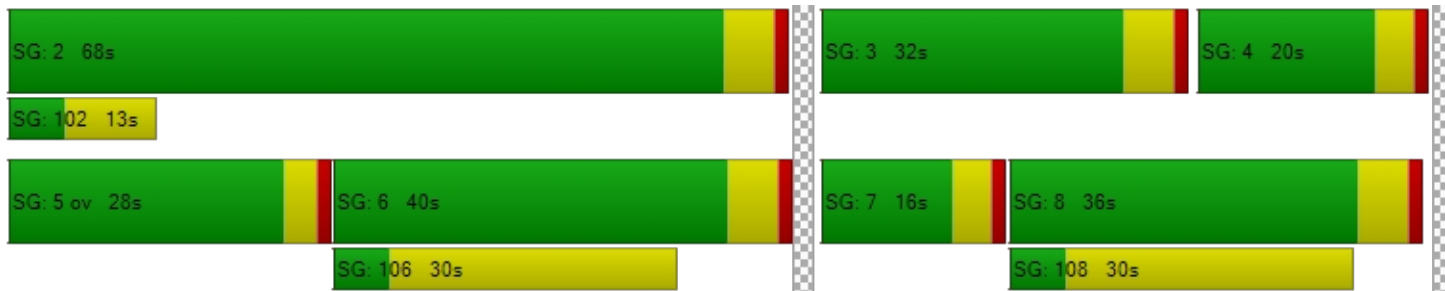



**Intersection Level Of Service Report**  
**Intersection 6: Tassajara Road & Fallon Road**

Control Type:	Signalized	Delay (sec / veh):	15.6
Analysis Method:	HCM 7th Edition	Level Of Service:	B
Analysis Period:	15 minutes	Volume to Capacity (v/c):	0.427

**Intersection Setup**

Name	Fallon Road			Fallon Road			Tassajara Road			Syrah Drive		
Approach	Northbound			Southbound			Eastbound			Westbound		
Lane Configuration												
Turning Movement	Left	Thru	Right	Left	Thru	Right	Left	Thru	Right	Left	Thru	Right
Lane Width [ft]	12.00	12.00	12.00	12.00	12.00	12.00	12.00	12.00	12.00	12.00	12.00	12.00
No. of Lanes in Entry Pocket	1	0	1	1	0	2	1	0	1	1	0	1
Entry Pocket Length [ft]	175.00	100.00	175.00	175.00	100.00	225.00	475.00	100.00	175.00	100.00	100.00	100.00
No. of Lanes in Exit Pocket	0	0	0	0	0	0	0	0	0	0	0	0
Exit Pocket Length [ft]	0.00	0.00	0.00	0.00	0.00	0.00	0.00	0.00	0.00	0.00	0.00	0.00
Speed [mph]	30.00			30.00			30.00			30.00		
Grade [%]	0.00			0.00			0.00			0.00		
Curb Present	No			No			No			No		
Crosswalk	Yes			Yes			Yes			Yes		



**Volumes**

Name	Fallon Road			Fallon Road			Tassajara Road			Syrah Drive		
Base Volume Input [veh/h]	60	319	21	5	317	348	462	26	65	4	17	6
Base Volume Adjustment Factor	1.0000	1.0000	1.0000	1.0000	1.0000	1.0000	1.0000	1.0000	1.0000	1.0000	1.0000	1.0000
Heavy Vehicles Percentage [%]	0.00	0.00	4.80	0.00	2.50	0.30	0.20	0.00	0.00	0.00	0.00	20.00
Proportion of CAVs [%]	0.00											
Growth Factor	1.0000	1.0000	1.0000	1.0000	1.0000	1.0000	1.0000	1.0000	1.0000	1.0000	1.0000	1.0000
In-Process Volume [veh/h]	0	0	0	0	0	0	0	0	0	0	0	0
Site-Generated Trips [veh/h]	0	0	0	0	0	0	0	0	0	0	0	0
Diverted Trips [veh/h]	0	0	0	0	0	0	0	0	0	0	0	0
Pass-by Trips [veh/h]	0	0	0	0	0	0	0	0	0	0	0	0
Existing Site Adjustment Volume [veh/h]	0	0	0	0	0	0	0	0	0	0	0	0
Other Volume [veh/h]	0	0	0	0	0	0	0	0	0	0	0	0
Right Turn on Red Volume [veh/h]	0	0	0	0	0	0	0	0	0	0	0	0
Total Hourly Volume [veh/h]	60	319	21	5	317	348	462	26	65	4	17	6
Peak Hour Factor	0.9200	0.9200	0.9200	0.9200	0.9200	0.9200	0.9200	0.9200	0.9200	0.9200	0.9200	0.9200
Other Adjustment Factor	1.0000	1.0000	1.0000	1.0000	1.0000	1.0000	1.0000	1.0000	1.0000	1.0000	1.0000	1.0000
Total 15-Minute Volume [veh/h]	16	87	6	1	86	95	126	7	18	1	5	2
Total Analysis Volume [veh/h]	65	347	23	5	345	378	502	28	71	4	18	7
Presence of On-Street Parking	No		No	No		No	No		No	No		No
On-Street Parking Maneuver Rate [/h]	0	0	0	0	0	0	0	0	0	0	0	0
Local Bus Stopping Rate [/h]	0	0	0	0	0	0	0	0	0	0	0	0
v_do, Outbound Pedestrian Volume crossing	0			0			0			0		
v_di, Inbound Pedestrian Volume crossing m	0			0			0			0		
v_co, Outbound Pedestrian Volume crossing	0			0			0			0		
v_ci, Inbound Pedestrian Volume crossing mi	0			0			0			0		
v_ab, Corner Pedestrian Volume [ped/h]	0			0			0			0		
Bicycle Volume [bicycles/h]	0			0			0			0		



**Intersection Settings**

Located in CBD	No
Signal Coordination Group	-
Cycle Length [s]	90
Active Pattern	Free Running (No Pattern)
Coordination Type	<i>Free Running</i>
Actuation Type	<i>Fully actuated</i>
Offset [s]	0.0
Offset Reference	Lead Green - Beginning of First Green
Permissive Mode	SingleBand
Lost time [s]	12.00

**Phasing & Timing (Basic)**

Control Type	Protecte	Permiss	Permiss	Protecte	Permiss	Permiss	Protecte	Permiss	Permiss	Protecte	Permiss	Permiss
Signal Group	3	8	0	7	4	0	5	2	0	1	6	0
Auxiliary Signal Groups												
Maximum Green [s]	25	50	0	25	50	0	35	30	0	20	30	0
Amber [s]	3.5	4.8	0.0	3.5	4.8	0.0	3.5	5.0	0.0	3.0	3.6	0.0
All red [s]	1.0	1.0	0.0	1.0	1.0	0.0	1.0	1.0	0.0	1.0	1.0	0.0
Walk [s]	0	4	0	0	0	0	0	4	0	0	3	0
Pedestrian Clearance [s]	0	25	0	0	0	0	0	28	0	0	36	0
Delayed Vehicle Green [s]	0.0	0.0	0.0	0.0	0.0	0.0	0.0	0.0	0.0	0.0	0.0	0.0
Rest In Walk		No			No			No			No	
I1, Start-Up Lost Time [s]	2.0	2.0	0.0	2.0	2.0	0.0	2.0	2.0	0.0	2.0	2.0	0.0
I2, Clearance Lost Time [s]	2.0	2.0	0.0	2.0	2.0	0.0	2.0	2.0	0.0	2.0	2.0	0.0
Detector Location [ft]	0.0	0.0	0.0	0.0	0.0	0.0	0.0	0.0	0.0	0.0	0.0	0.0
Detector Length [ft]	0.0	0.0	0.0	0.0	0.0	0.0	0.0	0.0	0.0	0.0	0.0	0.0
I, Upstream Filtering Factor	1.00	1.00	1.00	1.00	1.00	1.00	1.00	1.00	1.00	1.00	1.00	1.00

**Phasing & Timing: Free Running (No Pattern)**

Split [s]	0	0	0	0	0	0	0	0	0	0	0	0
Lead / Lag	Lead	-	-	Lead	-	-	Lead	-	-	Lead	-	-
Minimum Green [s]	9	10	0	9	10	0	11	8	0	12	9	0
Vehicle Extension [s]	3.0	3.0	0.0	3.0	3.0	0.0	3.0	3.0	0.0	3.0	3.0	0.0
Minimum Recall	No	No		No	No		Yes	No		No	No	
Maximum Recall	No	No		No	No		No	No		No	No	
Pedestrian Recall	No	No		No	No		No	No		No	No	

**Exclusive Pedestrian Phase**

Pedestrian Signal Group	0
Pedestrian Walk [s]	0
Pedestrian Clearance [s]	0



**Lane Group Calculations**

Lane Group	L	C	R	L	C	R	L	C	R	L	C	R
C, Cycle Length [s]	48	48	48	48	48	48	48	48	48	48	48	48
L, Total Lost Time per Cycle [s]	4.00	4.00	4.00	4.00	4.00	4.00	4.00	4.00	4.00	4.00	4.00	4.00
l1_p, Permitted Start-Up Lost Time [s]	0.00	0.00	0.00	0.00	0.00	0.00	0.00	0.00	0.00	0.00	0.00	0.00
l2, Clearance Lost Time [s]	2.00	2.00	2.00	2.00	2.00	2.00	2.00	2.00	2.00	2.00	2.00	2.00
g_i, Effective Green Time [s]	6	17	17	1	12	12	12	14	14	1	3	3
g / C, Green / Cycle	0.12	0.34	0.34	0.02	0.24	0.24	0.24	0.29	0.29	0.01	0.07	0.07
(v / s)_i Volume / Saturation Flow Rate	0.04	0.10	0.01	0.00	0.10	0.13	0.14	0.01	0.04	0.00	0.01	0.01
s, saturation flow rate [veh/h]	1810	3618	1554	1810	3546	2852	3509	1900	1615	1810	1900	1360
c, Capacity [veh/h]	218	1238	532	42	867	698	835	553	470	25	127	91
d1, Uniform Delay [s]	19.45	11.60	10.65	23.21	15.33	15.95	16.44	12.36	12.74	23.65	21.31	21.22
k, delay calibration	0.11	0.11	0.11	0.11	0.11	0.11	0.11	0.11	0.11	0.11	0.11	0.11
l, Upstream Filtering Factor	1.00	1.00	1.00	1.00	1.00	1.00	1.00	1.00	1.00	1.00	1.00	1.00
d2, Incremental Delay [s]	0.75	0.12	0.03	1.27	0.30	0.66	0.70	0.04	0.15	3.06	0.50	0.35
d3, Initial Queue Delay [s]	0.00	0.00	0.00	0.00	0.00	0.00	0.00	0.00	0.00	0.00	0.00	0.00
Rp, platoon ratio	1.00	1.00	1.00	1.00	1.00	1.00	1.00	1.00	1.00	1.00	1.00	1.00
PF, progression factor	1.00	1.00	1.00	1.00	1.00	1.00	1.00	1.00	1.00	1.00	1.00	1.00

**Lane Group Results**

X, volume / capacity	0.30	0.28	0.04	0.12	0.40	0.54	0.60	0.05	0.15	0.16	0.14	0.08
d, Delay for Lane Group [s/veh]	20.20	11.73	10.68	24.48	15.62	16.61	17.14	12.40	12.89	26.71	21.81	21.57
Lane Group LOS	C	B	B	C	B	B	B	B	B	C	C	C
Critical Lane Group	Yes	No	No	No	No	Yes	Yes	No	No	No	Yes	No
50th-Percentile Queue Length [veh/ln]	0.65	1.16	0.14	0.07	1.42	1.65	2.23	0.19	0.51	0.06	0.19	0.08
50th-Percentile Queue Length [ft/ln]	16.20	29.10	3.60	1.65	35.58	41.14	55.85	4.86	12.80	1.56	4.83	1.92
95th-Percentile Queue Length [veh/ln]	1.17	2.10	0.26	0.12	2.56	2.96	4.02	0.35	0.92	0.11	0.35	0.14
95th-Percentile Queue Length [ft/ln]	29.17	52.38	6.48	2.97	64.04	74.06	100.53	8.75	23.04	2.81	8.69	3.46



**Movement, Approach, & Intersection Results**

d_M, Delay for Movement [s/veh]	20.20	11.73	10.68	24.48	15.62	16.61	17.14	12.40	12.89	26.71	21.81	21.57
Movement LOS	C	B	B	C	B	B	B	B	B	C	C	C
d_A, Approach Delay [s/veh]	12.94			16.20			16.41			22.43		
Approach LOS	B			B			B			C		
d_I, Intersection Delay [s/veh]	15.58											
Intersection LOS	B											
Intersection V/C	0.427											

**Emissions**

Vehicle Miles Traveled [mph]	6.19	33.07	2.19	0.54	37.45	41.03	64.74	3.61	9.16	0.14	0.65	0.25
Stops [stops/h]	48.26	173.32	10.72	4.92	211.91	245.05	332.66	14.47	38.12	4.65	14.39	5.73
Fuel consumption [US gal/h]	0.79	3.15	0.20	0.07	3.81	4.32	6.25	0.30	0.77	0.05	0.19	0.07
CO [g/h]	55.14	219.98	13.94	5.20	266.28	302.02	437.14	20.92	54.09	3.73	13.00	5.08
NOx [g/h]	10.73	42.80	2.71	1.01	51.81	58.76	85.05	4.07	10.52	0.73	2.53	0.99
VOC [g/h]	12.78	50.98	3.23	1.21	61.71	70.00	101.31	4.85	12.53	0.86	3.01	1.18

**Other Modes**

g_Walk,mi, Effective Walk Time [s]	8.0			7.0			-5.8			8.0		
M_corner, Corner Circulation Area [ft <sup>2</sup> /ped]	0.00			0.00			0.00			0.00		
M_CW, Crosswalk Circulation Area [ft <sup>2</sup> /ped]	0.00			0.00			0.00			0.00		
d_p, Pedestrian Delay [s]	16.84			17.68			30.32			16.84		
I_p,int, Pedestrian LOS Score for Intersectio	2.562			2.787			2.620			2.122		
Crosswalk LOS	B			C			B			B		
s_b, Saturation Flow Rate of the bicycle lane	2000			2000			2000			2000		
c_b, Capacity of the bicycle lane [bicycles/h]	2068			2068			1241			1241		
d_b, Bicycle Delay [s]	0.03			0.03			3.48			3.48		
I_b,int, Bicycle LOS Score for Intersection	1.918			2.160			2.551			1.607		
Bicycle LOS	A			B			B			A		

**Sequence**

Ring 1	1	2	3	4	-	-	-	-	-	-	-	-	-	-	-
Ring 2	5	6	7	8	-	-	-	-	-	-	-	-	-	-	-
Ring 3	-	-	-	-	-	-	-	-	-	-	-	-	-	-	-
Ring 4	-	-	-	-	-	-	-	-	-	-	-	-	-	-	-

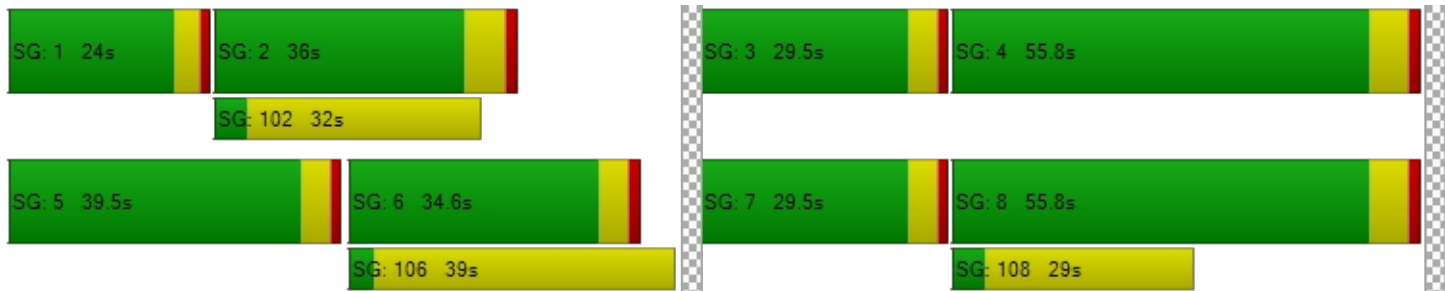

**Intersection Level Of Service Report**  
**Intersection 7: Fallon Road & Positano Parkway**

Control Type:	Signalized	Delay (sec / veh):	10.7
Analysis Method:	HCM 7th Edition	Level Of Service:	B
Analysis Period:	15 minutes	Volume to Capacity (v/c):	0.556

**Intersection Setup**

Name	Fallon Road		Fallon Road		Positano Parkway	
Approach	Northbound		Southbound		Westbound	
Lane Configuration	↑↑↑↔		↔↑↑↑		↔↔↔	
Turning Movement	Thru	Right	Left	Thru	Left	Right
Lane Width [ft]	12.00	12.00	12.00	12.00	12.00	12.00
No. of Lanes in Entry Pocket	0	1	1	0	1	1
Entry Pocket Length [ft]	100.00	225.00	325.00	100.00	375.00	425.00
No. of Lanes in Exit Pocket	0	0	0	0	0	0
Exit Pocket Length [ft]	0.00	0.00	0.00	0.00	0.00	0.00
Speed [mph]	30.00		30.00		30.00	
Grade [%]	0.00		0.00		0.00	
Curb Present	No		No		No	
Crosswalk	Yes		Yes		Yes	



**Volumes**

Name	Fallon Road		Fallon Road		Positano Parkway	
Base Volume Input [veh/h]	504	350	175	478	320	102
Base Volume Adjustment Factor	1.0000	1.0000	1.0000	1.0000	1.0000	1.0000
Heavy Vehicles Percentage [%]	0.20	0.00	0.00	1.50	0.00	0.00
Proportion of CAVs [%]	0.00					
Growth Factor	1.0000	1.0000	1.0000	1.0000	1.0000	1.0000
In-Process Volume [veh/h]	0	0	0	0	0	0
Site-Generated Trips [veh/h]	0	0	0	0	0	0
Diverted Trips [veh/h]	0	0	0	0	0	0
Pass-by Trips [veh/h]	0	0	0	0	0	0
Existing Site Adjustment Volume [veh/h]	0	0	0	0	0	0
Other Volume [veh/h]	0	0	0	0	0	0
Right Turn on Red Volume [veh/h]	0	0	0	0	0	0
Total Hourly Volume [veh/h]	504	350	175	478	320	102
Peak Hour Factor	0.9300	0.9300	0.9300	0.9300	0.9300	0.9300
Other Adjustment Factor	1.0000	1.0000	1.0000	1.0000	1.0000	1.0000
Total 15-Minute Volume [veh/h]	135	94	47	128	86	27
Total Analysis Volume [veh/h]	542	376	188	514	344	110
Presence of On-Street Parking	No	No	No	No	No	No
On-Street Parking Maneuver Rate [/h]	0	0	0	0	0	0
Local Bus Stopping Rate [/h]	0	0	0	0	0	0
v_do, Outbound Pedestrian Volume crossing	0		1		0	
v_di, Inbound Pedestrian Volume crossing m	0		0		1	
v_co, Outbound Pedestrian Volume crossing	0		0		1	
v_ci, Inbound Pedestrian Volume crossing mi	1		0		0	
v_ab, Corner Pedestrian Volume [ped/h]	0		0		0	
Bicycle Volume [bicycles/h]	0		0		0	



**Intersection Settings**

Located in CBD	No
Signal Coordination Group	-
Cycle Length [s]	90
Active Pattern	Free Running (No Pattern)
Coordination Type	<i>Free Running</i>
Actuation Type	<i>Fully actuated</i>
Offset [s]	0.0
Offset Reference	Lead Green - Beginning of First Green
Permissive Mode	SingleBand
Lost time [s]	9.00

**Phasing & Timing (Basic)**

Control Type	Permissive	Permissive	Protected	Permissive	Permissive	Permissive
Signal Group	4	0	7	8	6	0
Auxiliary Signal Groups						
Maximum Green [s]	30	0	20	30	24	0
Amber [s]	4.3	0.0	3.5	4.3	4.0	0.0
All red [s]	1.0	0.0	1.0	1.0	1.0	0.0
Walk [s]	0	0	0	4	4	0
Pedestrian Clearance [s]	0	0	0	20	34	0
Delayed Vehicle Green [s]	0.0	0.0	0.0	0.0	0.0	0.0
Rest In Walk	No			No	No	
I1, Start-Up Lost Time [s]	2.0	0.0	2.0	2.0	2.0	0.0
I2, Clearance Lost Time [s]	2.0	0.0	2.0	2.0	2.0	0.0
Detector Location [ft]	0.0	0.0	0.0	0.0	0.0	0.0
Detector Length [ft]	20.0	0.0	20.0	20.0	20.0	0.0
I, Upstream Filtering Factor	1.00	1.00	1.00	1.00	1.00	1.00

**Phasing & Timing: Free Running (No Pattern)**

Split [s]	14	0	9	14	9	0
Lead / Lag	-	-	Lead	-	Lead	-
Minimum Green [s]	10	0	5	10	5	0
Vehicle Extension [s]	3.0	0.0	3.0	3.0	3.0	0.0
Minimum Recall	Yes		No	Yes	No	
Maximum Recall	No		No	No	No	
Pedestrian Recall	No		No	No	No	

**Exclusive Pedestrian Phase**

Pedestrian Signal Group	0
Pedestrian Walk [s]	0
Pedestrian Clearance [s]	0





**Lane Group Calculations**

Lane Group	C	R	L	C	L	R
C, Cycle Length [s]	41	41	41	41	41	41
L, Total Lost Time per Cycle [s]	4.00	4.00	4.00	4.00	4.00	4.00
l1_p, Permitted Start-Up Lost Time [s]	0.00	0.00	0.00	0.00	0.00	0.00
l2, Clearance Lost Time [s]	2.00	2.00	2.00	2.00	2.00	2.00
g_i, Effective Green Time [s]	15	15	6	25	8	8
g / C, Green / Cycle	0.36	0.36	0.15	0.61	0.20	0.20
(v / s)_i Volume / Saturation Flow Rate	0.10	0.23	0.10	0.10	0.10	0.07
s, saturation flow rate [veh/h]	5167	1615	1810	5114	3514	1613
c, Capacity [veh/h]	1844	576	276	3099	704	323
d1, Uniform Delay [s]	9.55	11.14	16.57	3.57	14.64	14.17
k, delay calibration	0.11	0.11	0.11	0.11	0.11	0.11
l, Upstream Filtering Factor	1.00	1.00	1.00	1.00	1.00	1.00
d2, Incremental Delay [s]	0.09	1.26	2.97	0.02	0.53	0.62
d3, Initial Queue Delay [s]	0.00	0.00	0.00	0.00	0.00	0.00
Rp, platoon ratio	1.00	1.00	1.00	1.00	1.00	1.00
PF, progression factor	1.00	1.00	1.00	1.00	1.00	1.00

**Lane Group Results**

X, volume / capacity	0.29	0.65	0.68	0.17	0.49	0.34
d, Delay for Lane Group [s/veh]	9.63	12.39	19.54	3.59	15.17	14.79
Lane Group LOS	A	B	B	A	B	B
Critical Lane Group	No	Yes	Yes	No	Yes	No
50th-Percentile Queue Length [veh/ln]	0.92	2.40	1.66	0.32	1.25	0.80
50th-Percentile Queue Length [ft/ln]	22.99	59.93	41.48	7.95	31.18	19.90
95th-Percentile Queue Length [veh/ln]	1.66	4.32	2.99	0.57	2.24	1.43
95th-Percentile Queue Length [ft/ln]	41.38	107.88	74.66	14.30	56.12	35.81

**Movement, Approach, & Intersection Results**

d_M, Delay for Movement [s/veh]	9.63	12.39	19.54	3.59	15.17	14.79
Movement LOS	A	B	B	A	B	B
d_A, Approach Delay [s/veh]	10.76		7.86		15.08	
Approach LOS	B		A		B	
d_I, Intersection Delay [s/veh]	10.73					
Intersection LOS	B					
Intersection V/C	0.556					

**Emissions**

Vehicle Miles Traveled [mph]	136.32	94.57	16.49	45.10	41.25	13.19
Stops [stops/h]	240.94	209.41	144.93	83.29	217.87	69.52
Fuel consumption [US gal/h]	8.01	6.00	2.23	2.69	3.96	1.26
CO [g/h]	559.59	419.29	155.69	188.19	277.06	87.95
NOx [g/h]	108.88	81.58	30.29	36.62	53.91	17.11
VOC [g/h]	129.69	97.17	36.08	43.62	64.21	20.38

**Other Modes**

g_Walk,mi, Effective Walk Time [s]	8.0		8.0		8.7	
M_corner, Corner Circulation Area [ft <sup>2</sup> /ped]	0.00		0.00		0.00	
M_CW, Crosswalk Circulation Area [ft <sup>2</sup> /ped]	0.00		0.00		0.00	
d_p, Pedestrian Delay [s]	13.38		13.38		12.83	
I_p,int, Pedestrian LOS Score for Intersectio	2.803		2.744		2.339	
Crosswalk LOS	C		B		B	
s_b, Saturation Flow Rate of the bicycle lane	2000		2000		2000	
c_b, Capacity of the bicycle lane [bicycles/h]	1456		1456		1165	
d_b, Bicycle Delay [s]	1.53		1.53		3.59	
I_b,int, Bicycle LOS Score for Intersection	2.065		1.946		1.560	
Bicycle LOS	B		A		A	

**Sequence**

Ring 1	-	-	-	8	-	-	-	-	-	-	-	-	-	-	-	-
Ring 2	-	6	7	4	-	-	-	-	-	-	-	-	-	-	-	-
Ring 3	-	-	-	-	-	-	-	-	-	-	-	-	-	-	-	-
Ring 4	-	-	-	-	-	-	-	-	-	-	-	-	-	-	-	-



**Intersection Level Of Service Report**  
**Intersection 8: Fallon Road & Central Parkway**

Control Type:	Signalized	Delay (sec / veh):	21.5
Analysis Method:	HCM 7th Edition	Level Of Service:	C
Analysis Period:	15 minutes	Volume to Capacity (v/c):	0.406

**Intersection Setup**

Name	Fallon Road			Fallon Road			Central Parkway			Central Parkway		
Approach	Northbound			Southbound			Eastbound			Westbound		
Lane Configuration												
Turning Movement	Left	Thru	Right	Left	Thru	Right	Left	Thru	Right	Left	Thru	Right
Lane Width [ft]	12.00	12.00	12.00	12.00	12.00	12.00	12.00	12.00	12.00	12.00	12.00	12.00
No. of Lanes in Entry Pocket	2	0	1	1	0	1	2	0	2	2	0	1
Entry Pocket Length [ft]	300.00	100.00	255.00	295.00	100.00	245.00	350.00	100.00	230.00	250.00	100.00	250.00
No. of Lanes in Exit Pocket	0	0	1	0	0	2	0	0	0	0	0	0
Exit Pocket Length [ft]	0.00	0.00	250.00	0.00	0.00	500.00	0.00	0.00	0.00	0.00	0.00	0.00
Speed [mph]	40.00			30.00			25.00			30.00		
Grade [%]	0.00			0.00			0.00			0.00		
Curb Present	Yes			Yes			Yes			Yes		
Crosswalk	Yes			Yes			Yes			Yes		



**Volumes**

Name	Fallon Road			Fallon Road			Central Parkway			Central Parkway		
Base Volume Input [veh/h]	134	847	251	37	838	111	102	50	155	196	41	41
Base Volume Adjustment Factor	1.0000	1.0000	1.0000	1.0000	1.0000	1.0000	1.0000	1.0000	1.0000	1.0000	1.0000	1.0000
Heavy Vehicles Percentage [%]	0.70	0.10	0.00	0.00	0.40	0.00	0.00	0.00	0.00	0.00	0.00	0.00
Proportion of CAVs [%]	0.00											
Growth Factor	1.0000	1.0000	1.0000	1.0000	1.0000	1.0000	1.0000	1.0000	1.0000	1.0000	1.0000	1.0000
In-Process Volume [veh/h]	0	0	0	0	0	0	0	0	0	0	0	0
Site-Generated Trips [veh/h]	0	0	0	0	0	0	0	0	0	0	0	0
Diverted Trips [veh/h]	0	0	0	0	0	0	0	0	0	0	0	0
Pass-by Trips [veh/h]	0	0	0	0	0	0	0	0	0	0	0	0
Existing Site Adjustment Volume [veh/h]	0	0	0	0	0	0	0	0	0	0	0	0
Other Volume [veh/h]	0	0	0	0	0	0	0	0	0	0	0	0
Right Turn on Red Volume [veh/h]	0	0	0	0	0	0	0	0	0	0	0	0
Total Hourly Volume [veh/h]	134	847	251	37	838	111	102	50	155	196	41	41
Peak Hour Factor	0.9200	0.9200	0.9200	0.9200	0.9200	0.9200	0.9200	0.9200	0.9200	0.9200	0.9200	0.9200
Other Adjustment Factor	1.0000	1.0000	1.0000	1.0000	1.0000	1.0000	1.0000	1.0000	1.0000	1.0000	1.0000	1.0000
Total 15-Minute Volume [veh/h]	36	230	68	10	228	30	28	14	42	53	11	11
Total Analysis Volume [veh/h]	146	921	273	40	911	121	111	54	168	213	45	45
Presence of On-Street Parking	No		No	No		No	No		No	No		No
On-Street Parking Maneuver Rate [/h]	0	0	0	0	0	0	0	0	0	0	0	0
Local Bus Stopping Rate [/h]	0	0	0	0	0	0	0	0	0	0	0	0
v_do, Outbound Pedestrian Volume crossing	1			4			4			1		
v_di, Inbound Pedestrian Volume crossing m	1			4			4			1		
v_co, Outbound Pedestrian Volume crossing	2			6			1			5		
v_ci, Inbound Pedestrian Volume crossing mi	1			5			2			6		
v_ab, Corner Pedestrian Volume [ped/h]	0			0			0			0		
Bicycle Volume [bicycles/h]	0			1			0			0		



**Intersection Settings**

Located in CBD	No
Signal Coordination Group	-
Cycle Length [s]	90
Active Pattern	Free Running (No Pattern)
Coordination Type	<i>Free Running</i>
Actuation Type	<i>Fully actuated</i>
Offset [s]	0.0
Offset Reference	Lead Green - Beginning of First Green
Permissive Mode	SingleBand
Lost time [s]	12.00

**Phasing & Timing (Basic)**

Control Type	Protecte	Permiss	Permiss	Protecte	Permiss	Permiss	Protecte	Permiss	Permiss	Protecte	Permiss	Permiss
Signal Group	3	8	0	7	4	0	5	2	0	1	6	0
Auxiliary Signal Groups												
Maximum Green [s]	20	30	0	20	30	0	20	30	0	20	30	0
Amber [s]	3.5	4.3	0.0	3.0	4.3	0.0	3.0	4.0	0.0	3.0	4.0	0.0
All red [s]	1.0	1.0	0.0	1.0	1.0	0.0	1.0	1.0	0.0	1.0	1.0	0.0
Walk [s]	0	4	0	0	4	0	0	4	0	0	4	0
Pedestrian Clearance [s]	0	28	0	0	34	0	0	42	0	0	41	0
Delayed Vehicle Green [s]	0.0	0.0	0.0	0.0	0.0	0.0	0.0	0.0	0.0	0.0	0.0	0.0
Rest In Walk		No			No			No			No	
I1, Start-Up Lost Time [s]	2.0	2.0	0.0	2.0	2.0	0.0	2.0	2.0	0.0	2.0	2.0	0.0
I2, Clearance Lost Time [s]	2.0	2.0	0.0	2.0	2.0	0.0	2.0	2.0	0.0	2.0	2.0	0.0
Detector Location [ft]	0.0	0.0	0.0	0.0	0.0	0.0	0.0	0.0	0.0	0.0	0.0	0.0
Detector Length [ft]	20.0	20.0	0.0	20.0	20.0	0.0	20.0	20.0	0.0	20.0	20.0	0.0
I, Upstream Filtering Factor	1.00	1.00	1.00	1.00	1.00	1.00	1.00	1.00	1.00	1.00	1.00	1.00

**Phasing & Timing: Free Running (No Pattern)**

Split [s]	0	0	0	0	0	0	0	0	0	0	0	0
Lead / Lag	Lead	-	-	Lead	-	-	Lead	-	-	Lead	-	-
Minimum Green [s]	10	12	0	10	12	0	10	12	0	10	12	0
Vehicle Extension [s]	2.0	4.0	0.0	2.0	4.0	0.0	2.0	4.0	0.0	2.0	4.0	0.0
Minimum Recall	No	Yes		No	Yes		No	No		No	No	
Maximum Recall	No	No		No	No		No	No		No	No	
Pedestrian Recall	No	No		No	No		No	No		No	No	

**Exclusive Pedestrian Phase**

Pedestrian Signal Group	0
Pedestrian Walk [s]	0
Pedestrian Clearance [s]	0



**Lane Group Calculations**

Lane Group	L	C	R	L	C	R	L	C	R	L	C	R
C, Cycle Length [s]	72	72	72	72	72	72	72	72	72	72	72	72
L, Total Lost Time per Cycle [s]	4.00	4.00	4.00	4.00	4.00	4.00	4.00	4.00	4.00	4.00	4.00	4.00
l1_p, Permitted Start-Up Lost Time [s]	0.00	0.00	0.00	0.00	0.00	0.00	0.00	0.00	0.00	0.00	0.00	0.00
l2, Clearance Lost Time [s]	2.00	2.00	2.00	2.00	2.00	2.00	2.00	2.00	2.00	2.00	2.00	2.00
g_i, Effective Green Time [s]	10	26	26	6	22	22	9	14	14	10	15	15
g / C, Green / Cycle	0.14	0.37	0.37	0.08	0.30	0.30	0.12	0.19	0.19	0.14	0.21	0.21
(v / s)_i Volume / Saturation Flow Rate	0.04	0.18	0.17	0.02	0.18	0.08	0.03	0.03	0.06	0.06	0.02	0.03
s, saturation flow rate [veh/h]	3495	5172	1611	1810	5159	1582	3514	1900	2845	3514	1900	1589
c, Capacity [veh/h]	487	1895	590	140	1572	482	439	370	554	484	395	330
d1, Uniform Delay [s]	27.69	17.49	17.30	31.17	21.04	18.72	28.33	23.90	24.67	28.35	23.03	23.12
k, delay calibration	0.04	0.15	0.15	0.04	0.15	0.15	0.04	0.15	0.15	0.04	0.15	0.15
l, Upstream Filtering Factor	1.00	1.00	1.00	1.00	1.00	1.00	1.00	1.00	1.00	1.00	1.00	1.00
d2, Incremental Delay [s]	0.13	0.28	0.81	0.41	0.49	0.39	0.11	0.26	0.43	0.23	0.18	0.26
d3, Initial Queue Delay [s]	0.00	0.00	0.00	0.00	0.00	0.00	0.00	0.00	0.00	0.00	0.00	0.00
Rp, platoon ratio	1.00	1.00	1.00	1.00	1.00	1.00	1.00	1.00	1.00	1.00	1.00	1.00
PF, progression factor	1.00	1.00	1.00	1.00	1.00	1.00	1.00	1.00	1.00	1.00	1.00	1.00

**Lane Group Results**

X, volume / capacity	0.30	0.49	0.46	0.29	0.58	0.25	0.25	0.15	0.30	0.44	0.11	0.14
d, Delay for Lane Group [s/veh]	27.82	17.77	18.11	31.58	21.52	19.11	28.44	24.16	25.10	28.58	23.21	23.39
Lane Group LOS	C	B	B	C	C	B	C	C	C	C	C	C
Critical Lane Group	Yes	No	No	No	Yes	No	No	No	Yes	Yes	No	No
50th-Percentile Queue Length [veh/ln]	1.06	3.50	3.17	0.65	4.10	1.48	0.85	0.77	1.22	1.63	0.61	0.62
50th-Percentile Queue Length [ft/ln]	26.42	87.57	79.26	16.19	102.59	37.05	21.27	19.19	30.60	40.75	15.30	15.48
95th-Percentile Queue Length [veh/ln]	1.90	6.30	5.71	1.17	7.39	2.67	1.53	1.38	2.20	2.93	1.10	1.11
95th-Percentile Queue Length [ft/ln]	47.55	157.62	142.66	29.15	184.67	66.69	38.28	34.54	55.07	73.35	27.55	27.86



**Movement, Approach, & Intersection Results**

d_M, Delay for Movement [s/veh]	27.82	17.77	18.11	31.58	21.52	19.11	28.44	24.16	25.10	28.58	23.21	23.39
Movement LOS	C	B	B	C	C	B	C	C	C	C	C	C
d_A, Approach Delay [s/veh]	18.93			21.62			26.06			27.01		
Approach LOS	B			C			C			C		
d_I, Intersection Delay [s/veh]	21.46											
Intersection LOS	C											
Intersection V/C	0.406											

**Emissions**

Vehicle Miles Traveled [mph]	38.66	243.85	72.28	10.06	229.12	30.43	9.70	4.72	14.68	48.42	10.23	10.23
Stops [stops/h]	106.39	529.01	159.60	32.61	619.78	74.61	85.66	38.65	123.22	164.13	30.82	31.17
Fuel consumption [US gal/h]	3.26	17.26	5.16	0.85	16.85	2.14	1.41	0.63	1.99	4.14	0.80	0.81
CO [g/h]	227.61	1206.66	360.91	59.51	1177.56	149.28	98.37	43.75	139.19	289.32	56.19	56.45
NOx [g/h]	44.29	234.77	70.22	11.58	229.11	29.04	19.14	8.51	27.08	56.29	10.93	10.98
VOC [g/h]	52.75	279.66	83.64	13.79	272.91	34.60	22.80	10.14	32.26	67.05	13.02	13.08

**Other Modes**

g_Walk,mi, Effective Walk Time [s]	8.0			8.0			8.0			8.0		
M_corner, Corner Circulation Area [ft <sup>2</sup> /ped]	0.00			0.00			0.00			0.00		
M_CW, Crosswalk Circulation Area [ft <sup>2</sup> /ped]	0.00			0.00			0.00			0.00		
d_p, Pedestrian Delay [s]	28.20			28.20			28.20			28.20		
I_p,int, Pedestrian LOS Score for Intersectio	3.221			3.167			2.660			2.422		
Crosswalk LOS	C			C			B			B		
s_b, Saturation Flow Rate of the bicycle lane	2000			2000			2000			2000		
c_b, Capacity of the bicycle lane [bicycles/h]	839			839			839			839		
d_b, Bicycle Delay [s]	12.05			12.05			12.05			12.05		
I_b,int, Bicycle LOS Score for Intersection	2.297			2.149			2.109			2.060		
Bicycle LOS	B			B			B			B		

**Sequence**

Ring 1	1	2	3	4	-	-	-	-	-	-	-	-	-	-	-
Ring 2	5	6	7	8	-	-	-	-	-	-	-	-	-	-	-
Ring 3	-	-	-	-	-	-	-	-	-	-	-	-	-	-	-
Ring 4	-	-	-	-	-	-	-	-	-	-	-	-	-	-	-

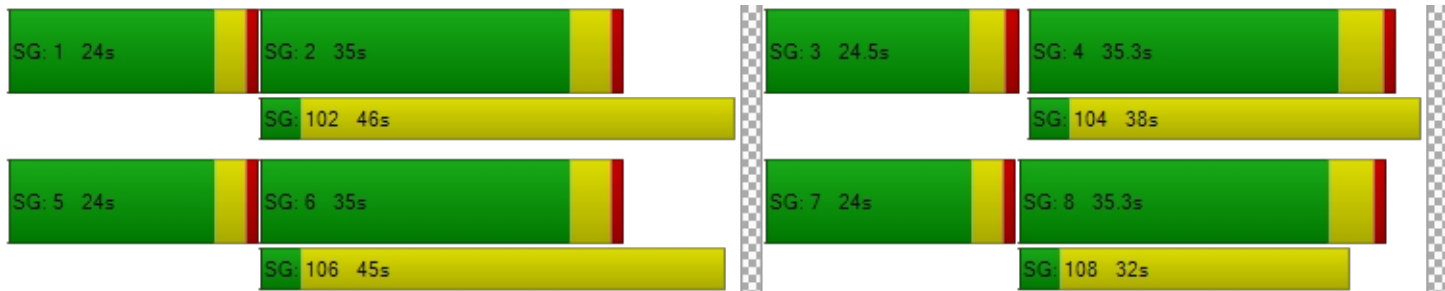

**Intersection Level Of Service Report**  
**Intersection 9: Fallon Road & Dublin Boulevard**

Control Type:	Signalized	Delay (sec / veh):	34.2
Analysis Method:	HCM 7th Edition	Level Of Service:	C
Analysis Period:	15 minutes	Volume to Capacity (v/c):	0.680

**Intersection Setup**

Name	Fallon Road			Fallon Road			Dublin Boulevard			Dublin Boulevard		
Approach	Northbound			Southbound			Eastbound			Westbound		
Lane Configuration	T T T			T T T			T T T T			T T		
Turning Movement	Left	Thru	Right	Left	Thru	Right	Left	Thru	Right	Left	Thru	Right
Lane Width [ft]	12.00	12.00	12.00	12.00	12.00	12.00	12.00	12.00	12.00	12.00	12.00	12.00
No. of Lanes in Entry Pocket	2	0	0	1	0	1	1	0	1	0	0	0
Entry Pocket Length [ft]	430.00	100.00	100.00	140.00	100.00	225.00	400.00	100.00	400.00	100.00	100.00	100.00
No. of Lanes in Exit Pocket	0	0	0	0	0	0	0	0	1	0	0	0
Exit Pocket Length [ft]	0.00	0.00	0.00	0.00	0.00	0.00	0.00	0.00	500.00	0.00	0.00	0.00
Speed [mph]	45.00			45.00			45.00			45.00		
Grade [%]	0.00			0.00			0.00			0.00		
Curb Present	Yes			Yes			Yes			Yes		
Crosswalk	No			No			Yes			Yes		





**Volumes**

Name	Fallon Road			Fallon Road			Dublin Boulevard			Dublin Boulevard		
Base Volume Input [veh/h]	222	959	0	0	996	133	243	446	372	0	0	0
Base Volume Adjustment Factor	1.0000	1.0000	1.0000	1.0000	1.0000	1.0000	1.0000	1.0000	1.0000	1.0000	1.0000	1.0000
Heavy Vehicles Percentage [%]	3.70	0.30	4.00	1.00	0.70	1.60	0.00	4.00	2.20	1.00	1.00	1.00
Proportion of CAVs [%]	0.00											
Growth Factor	1.0000	1.0000	1.0000	1.0000	1.0000	1.0000	1.0000	1.0000	1.0000	1.0000	1.0000	1.0000
In-Process Volume [veh/h]	0	0	0	0	0	0	0	0	0	0	0	0
Site-Generated Trips [veh/h]	0	0	0	0	0	0	0	0	0	0	0	0
Diverted Trips [veh/h]	0	0	0	0	0	0	0	0	0	0	0	0
Pass-by Trips [veh/h]	0	0	0	0	0	0	0	0	0	0	0	0
Existing Site Adjustment Volume [veh/h]	0	0	0	0	0	0	0	0	0	0	0	0
Other Volume [veh/h]	0	0	0	0	0	0	0	0	0	0	0	0
Right Turn on Red Volume [veh/h]	0	0	0	0	0	0	0	0	0	0	0	0
Total Hourly Volume [veh/h]	222	959	0	0	996	133	243	446	372	0	0	0
Peak Hour Factor	0.9400	0.9400	0.9400	0.9400	0.9400	0.9400	0.9400	0.9400	0.9400	0.9400	0.9400	0.9400
Other Adjustment Factor	1.0000	1.0000	1.0000	1.0000	1.0000	1.0000	1.0000	1.0000	1.0000	1.0000	1.0000	1.0000
Total 15-Minute Volume [veh/h]	59	255	0	0	265	35	65	119	99	0	0	0
Total Analysis Volume [veh/h]	236	1020	0	0	1060	141	259	474	396	0	0	0
Presence of On-Street Parking	No		No	No		No	No		No	No		No
On-Street Parking Maneuver Rate [/h]	0	0	0	0	0	0	0	0	0	0	0	0
Local Bus Stopping Rate [/h]	0	0	0	0	0	0	0	0	0	0	0	0
v_do, Outbound Pedestrian Volume crossing	0			0			0			0		
v_di, Inbound Pedestrian Volume crossing m	0			0			0			0		
v_co, Outbound Pedestrian Volume crossing	0			2			3			0		
v_ci, Inbound Pedestrian Volume crossing mi	0			3			2			0		
v_ab, Corner Pedestrian Volume [ped/h]	0			0			0			0		
Bicycle Volume [bicycles/h]	0			1			0			0		



**Intersection Settings**

Located in CBD	No
Signal Coordination Group	-
Cycle Length [s]	140
Active Pattern	Pattern 1
Coordination Type	Time of Day Pattern Isolated
Actuation Type	Fully actuated
Offset [s]	0.0
Offset Reference	Lead Green - Beginning of First Green
Permissive Mode	SingleBand
Lost time [s]	12.00

**Phasing & Timing (Basic)**

Control Type	Protecte	Permiss	Permiss	Protecte	Permiss	Permiss	Protecte	Permiss	Overlap	Protecte	Permiss	Permiss
Signal Group	3	8	0	7	4	0	5	2	2	1	6	0
Auxiliary Signal Groups									2,3			
Maximum Green [s]	30	30	0	12	30	0	30	30	30	12	12	0
Amber [s]	4.3	4.7	0.0	4.3	4.7	0.0	4.3	4.3	4.3	3.0	4.8	0.0
All red [s]	1.0	1.0	0.0	1.0	1.0	0.0	1.0	1.0	1.0	1.0	1.0	0.0
Walk [s]	0	0	0	0	4	0	0	0	0	0	0	0
Pedestrian Clearance [s]	0	0	0	0	41	0	0	0	0	0	0	0
Delayed Vehicle Green [s]	0.0	0.0	0.0	0.0	0.0	0.0	0.0	0.0	0.0	0.0	0.0	0.0
Rest In Walk		No			No			No			No	
I1, Start-Up Lost Time [s]	2.0	2.0	0.0	2.0	2.0	0.0	2.0	2.0	2.0	2.0	2.0	0.0
I2, Clearance Lost Time [s]	2.0	2.0	0.0	2.0	2.0	0.0	2.0	2.0	2.0	2.0	2.0	0.0
Detector Location [ft]	0.0	0.0	0.0	0.0	0.0	0.0	0.0	0.0	0.0	0.0	0.0	0.0
Detector Length [ft]	20.0	20.0	0.0	20.0	20.0	0.0	0.0	0.0	0.0	20.0	20.0	0.0
I, Upstream Filtering Factor	1.00	1.00	1.00	1.00	1.00	1.00	1.00	1.00	1.00	1.00	1.00	1.00

**Phasing & Timing: Pattern 1**

Split [s]	35	65	0	20	50	0	35	35	35	20	20	0
Lead / Lag	Lead	-	-	Lead	-	-	Lead	-	-	Lead	-	-
Minimum Green [s]	10	12	0	10	12	0	10	12	12	10	10	0
Vehicle Extension [s]	2.0	4.0	0.0	2.0	4.0	0.0	2.0	4.0	4.0	2.0	2.0	0.0
Minimum Recall	No	Yes		No	Yes		No	No	No	No	No	
Maximum Recall	No	No		No	No		No	No	No	No	No	
Pedestrian Recall	No	No		No	No		No	No	No	No	No	

**Exclusive Pedestrian Phase**

Pedestrian Signal Group	0
Pedestrian Walk [s]	0
Pedestrian Clearance [s]	0



**Lane Group Calculations**

Lane Group	L	C	C	L	C	R	L	C	R	L	C
C, Cycle Length [s]	140	140	140	140	140	140	140	140	140	140	140
L, Total Lost Time per Cycle [s]	4.00	4.00	4.00	4.00	4.00	4.00	4.00	4.00	4.00	4.00	4.00
l1_p, Permitted Start-Up Lost Time [s]	0.00	0.00	0.00	0.00	0.00	0.00	0.00	0.00	0.00	0.00	0.00
l2, Clearance Lost Time [s]	2.00	2.00	2.00	2.00	2.00	2.00	2.00	2.00	0.00	2.00	2.00
g_i, Effective Green Time [s]	18	82	82	1	65	65	14	41	63	0	27
g / C, Green / Cycle	0.13	0.59	0.59	0.01	0.46	0.46	0.10	0.29	0.45	0.00	0.19
(v / s)_i Volume / Saturation Flow Rate	0.07	0.27	0.27	0.00	0.29	0.09	0.07	0.26	0.14	0.00	0.00
s, saturation flow rate [veh/h]	3411	1895	1895	1795	3598	1570	3514	1840	2809	1795	1885
c, Capacity [veh/h]	447	1111	1111	17	1671	729	343	533	1236	1	362
d1, Uniform Delay [s]	56.74	16.39	16.39	0.00	28.43	22.00	61.50	47.57	25.54	0.00	0.00
k, delay calibration	0.04	0.50	0.50	0.04	0.50	0.50	0.04	0.33	0.15	0.04	0.04
l, Upstream Filtering Factor	1.00	1.00	1.00	1.00	1.00	1.00	1.00	1.00	1.00	1.00	1.00
d2, Incremental Delay [s]	0.36	1.37	1.37	0.00	1.85	0.59	1.28	14.09	0.21	0.00	0.00
d3, Initial Queue Delay [s]	0.00	0.00	0.00	0.00	0.00	0.00	0.00	0.00	0.00	0.00	0.00
Rp, platoon ratio	1.00	1.00	1.00	1.00	1.00	1.00	1.00	1.00	1.00	1.00	1.00
PF, progression factor	1.00	1.00	1.00	1.00	1.00	1.00	1.00	1.00	1.00	1.00	1.00

**Lane Group Results**

X, volume / capacity	0.53	0.46	0.46	0.00	0.63	0.19	0.75	0.89	0.32	0.00	0.00
d, Delay for Lane Group [s/veh]	57.10	17.76	17.76	0.00	30.28	22.59	62.78	61.66	25.75	0.00	0.00
Lane Group LOS	E	B	B	A	C	C	E	E	C	A	A
Critical Lane Group	Yes	No	No	No	Yes	No	No	Yes	No	No	No
50th-Percentile Queue Length [veh/ln]	3.85	9.16	9.16	0.00	13.39	2.79	4.47	17.44	4.23	0.00	0.00
50th-Percentile Queue Length [ft/ln]	96.34	228.96	228.96	0.00	334.71	69.69	111.69	435.99	105.80	0.00	0.00
95th-Percentile Queue Length [veh/ln]	6.94	14.12	14.12	0.00	19.39	5.02	7.93	24.29	7.61	0.00	0.00
95th-Percentile Queue Length [ft/ln]	173.41	353.03	353.03	0.00	484.73	125.44	198.36	607.21	190.15	0.00	0.00



**Movement, Approach, & Intersection Results**

d_M, Delay for Movement [s/veh]	57.10	17.76	17.76	0.00	30.28	22.59	62.78	61.66	25.75	0.00	0.00	0.00
Movement LOS	E	B	B	A	C	C	E	E	C	A	A	A
d_A, Approach Delay [s/veh]	25.15			29.38			49.33			0.00		
Approach LOS	C			C			D			A		
d_I, Intersection Delay [s/veh]	34.18											
Intersection LOS	C											
Intersection V/C	0.680											

**Emissions**

Vehicle Miles Traveled [mph]	31.70	68.50	68.50	0.00	280.66	37.33	311.62	570.29	476.45	0.00	0.00
Stops [stops/h]	198.22	235.55	235.55	0.00	688.70	71.69	229.82	448.55	217.70	0.00	0.00
Fuel consumption [US gal/h]	6.29	7.12	7.12	0.00	24.71	2.82	16.85	31.07	21.11	0.00	0.00
CO [g/h]	439.89	497.69	497.69	0.00	1727.54	197.07	1177.64	2171.99	1475.84	0.00	0.00
NOx [g/h]	85.59	96.83	96.83	0.00	336.12	38.34	229.13	422.59	287.14	0.00	0.00
VOC [g/h]	101.95	115.34	115.34	0.00	400.37	45.67	272.93	503.38	342.04	0.00	0.00

**Other Modes**

g_Walk,mi, Effective Walk Time [s]	0.0			0.0			8.0			59.3		
M_corner, Corner Circulation Area [ft <sup>2</sup> /ped]	0.00			0.00			0.00			0.00		
M_CW, Crosswalk Circulation Area [ft <sup>2</sup> /ped]	0.00			0.00			778.44			0.00		
d_p, Pedestrian Delay [s]	0.00			0.00			62.21			23.25		
I_p,int, Pedestrian LOS Score for Intersectio	0.000			0.000			3.024			2.288		
Crosswalk LOS	F			F			C			B		
s_b, Saturation Flow Rate of the bicycle lane	2000			2000			2000			2000		
c_b, Capacity of the bicycle lane [bicycles/h]	847			633			424			203		
d_b, Bicycle Delay [s]	23.25			32.71			43.44			56.50		
I_b,int, Bicycle LOS Score for Intersection	2.596			2.550			3.422			1.560		
Bicycle LOS	B			B			C			A		

**Sequence**

Ring 1	1	2	3	4	-	-	-	-	-	-	-	-	-	-	-
Ring 2	5	6	7	8	-	-	-	-	-	-	-	-	-	-	-
Ring 3	-	-	-	-	-	-	-	-	-	-	-	-	-	-	-
Ring 4	-	-	-	-	-	-	-	-	-	-	-	-	-	-	-



**Intersection Level Of Service Report**  
**Intersection 10: Fallon Road & Fallon Gateway**

Control Type:	Signalized	Delay (sec / veh):	13.3
Analysis Method:	HCM 7th Edition	Level Of Service:	B
Analysis Period:	15 minutes	Volume to Capacity (v/c):	0.625

**Intersection Setup**

Name	Fallon Road		Fallon Road		Fallon Gateway	
Approach	Northbound		Southbound		Eastbound	
Lane Configuration	⇐⇐		⇐		⇐⇐⇐⇐	
Turning Movement	Left	Thru	Thru	Right	Left	Right
Lane Width [ft]	12.00	12.00	12.00	12.00	12.00	12.00
No. of Lanes in Entry Pocket	1	0	0	0	1	1
Entry Pocket Length [ft]	275.00	100.00	100.00	100.00	210.00	210.00
No. of Lanes in Exit Pocket	0	0	0	0	0	0
Exit Pocket Length [ft]	0.00	0.00	0.00	0.00	0.00	0.00
Speed [mph]	45.00		40.00		25.00	
Grade [%]	0.00		0.00		0.00	
Curb Present	Yes		Yes		Yes	
Crosswalk	No		No		Yes	



**Volumes**

Name	Fallon Road		Fallon Road		Fallon Gateway	
Base Volume Input [veh/h]	308	1114	1098	105	62	304
Base Volume Adjustment Factor	1.0000	1.0000	1.0000	1.0000	1.0000	1.0000
Heavy Vehicles Percentage [%]	1.00	0.60	1.30	1.00	0.00	1.30
Proportion of CAVs [%]	0.00					
Growth Factor	1.0000	1.0000	1.0000	1.0000	1.0000	1.0000
In-Process Volume [veh/h]	0	0	0	0	0	0
Site-Generated Trips [veh/h]	0	0	0	0	0	0
Diverted Trips [veh/h]	0	0	0	0	0	0
Pass-by Trips [veh/h]	0	0	0	0	0	0
Existing Site Adjustment Volume [veh/h]	0	0	0	0	0	0
Other Volume [veh/h]	0	0	0	0	0	0
Right Turn on Red Volume [veh/h]	0	0	0	0	0	0
Total Hourly Volume [veh/h]	308	1114	1098	105	62	304
Peak Hour Factor	0.9400	0.9400	0.9400	0.9400	0.9400	0.9400
Other Adjustment Factor	1.0000	1.0000	1.0000	1.0000	1.0000	1.0000
Total 15-Minute Volume [veh/h]	82	296	292	28	16	81
Total Analysis Volume [veh/h]	328	1185	1168	112	66	323
Presence of On-Street Parking	No	No	No	No	No	No
On-Street Parking Maneuver Rate [/h]	0	0	0	0	0	0
Local Bus Stopping Rate [/h]	0	0	0	0	0	0
v_do, Outbound Pedestrian Volume crossing	0		0		0	
v_di, Inbound Pedestrian Volume crossing m	0		0		0	
v_co, Outbound Pedestrian Volume crossing	0		0		0	
v_ci, Inbound Pedestrian Volume crossing mi	0		0		0	
v_ab, Corner Pedestrian Volume [ped/h]	0		0		0	
Bicycle Volume [bicycles/h]	0		0		0	



**Intersection Settings**

Located in CBD	No
Signal Coordination Group	-
Cycle Length [s]	105
Active Pattern	Pattern 1
Coordination Type	Time of Day Pattern Isolated
Actuation Type	Fully actuated
Offset [s]	0.0
Offset Reference	Lead Green - Beginning of First Green
Permissive Mode	SingleBand
Lost time [s]	9.00

**Phasing & Timing (Basic)**

Control Type	Protected	Permissive	Permissive	Permissive	Permissive	Overlap
Signal Group	3	8	4	0	2	2
Auxiliary Signal Groups						2,3
Maximum Green [s]	20	40	40	0	30	30
Amber [s]	3.5	4.7	4.7	0.0	3.5	3.5
All red [s]	1.0	1.0	1.0	0.0	1.0	1.0
Walk [s]	0	0	4	0	0	0
Pedestrian Clearance [s]	0	0	28	0	0	0
Delayed Vehicle Green [s]	0.0	0.0	0.0	0.0	0.0	0.0
Rest In Walk		No	No		No	
I1, Start-Up Lost Time [s]	2.0	2.0	2.0	0.0	2.0	2.0
I2, Clearance Lost Time [s]	2.5	3.7	3.7	0.0	2.5	2.5
Detector Location [ft]	0.0	0.0	0.0	0.0	0.0	0.0
Detector Length [ft]	20.0	20.0	0.0	0.0	20.0	20.0
I, Upstream Filtering Factor	1.00	1.00	1.00	1.00	1.00	1.00

**Phasing & Timing: Pattern 1**

Split [s]	25	70	45	0	35	35
Lead / Lag	Lead	-	-	-	Lead	-
Minimum Green [s]	10	10	10	0	10	10
Vehicle Extension [s]	2.0	5.0	5.0	0.0	2.0	2.0
Minimum Recall	No	Yes	Yes		No	No
Maximum Recall	No	No	No		No	No
Pedestrian Recall	No	No	No		No	No

**Exclusive Pedestrian Phase**

Pedestrian Signal Group	0
Pedestrian Walk [s]	0
Pedestrian Clearance [s]	0



**Lane Group Calculations**

Lane Group	L	C	C	C	L	R
C, Cycle Length [s]	65	65	65	65	65	65
L, Total Lost Time per Cycle [s]	4.50	5.70	5.70	5.70	4.50	4.50
l1_p, Permitted Start-Up Lost Time [s]	0.00	0.00	0.00	0.00	0.00	0.00
l2, Clearance Lost Time [s]	2.50	3.70	3.70	3.70	2.50	0.00
g_i, Effective Green Time [s]	10	44	30	30	10	24
g / C, Green / Cycle	0.15	0.69	0.46	0.46	0.15	0.38
(v / s)_i Volume / Saturation Flow Rate	0.09	0.33	0.34	0.35	0.02	0.11
s, saturation flow rate [veh/h]	3486	3600	1880	1824	3514	2829
c, Capacity [veh/h]	538	2475	872	846	544	1072
d1, Uniform Delay [s]	25.53	4.71	14.11	14.34	23.55	14.09
k, delay calibration	0.04	0.23	0.23	0.24	0.04	0.04
l, Upstream Filtering Factor	1.00	1.00	1.00	1.00	1.00	1.00
d2, Incremental Delay [s]	0.42	0.31	2.60	3.11	0.04	0.06
d3, Initial Queue Delay [s]	0.00	0.00	0.00	0.00	0.00	0.00
Rp, platoon ratio	1.00	1.00	1.00	1.00	1.00	1.00
PF, progression factor	1.00	1.00	1.00	1.00	1.00	1.00

**Lane Group Results**

X, volume / capacity	0.61	0.48	0.73	0.76	0.12	0.30
d, Delay for Lane Group [s/veh]	25.94	5.02	16.71	17.45	23.58	14.15
Lane Group LOS	C	A	B	B	C	B
Critical Lane Group	Yes	No	No	Yes	No	Yes
50th-Percentile Queue Length [veh/ln]	2.13	1.91	6.74	6.94	0.42	1.56
50th-Percentile Queue Length [ft/ln]	53.32	47.83	168.46	173.46	10.59	38.90
95th-Percentile Queue Length [veh/ln]	3.84	3.44	11.00	11.26	0.76	2.80
95th-Percentile Queue Length [ft/ln]	95.97	86.10	274.90	281.45	19.06	70.02



**Movement, Approach, & Intersection Results**

d_M, Delay for Movement [s/veh]	25.94	5.02	17.04	17.45	23.58	14.15
Movement LOS	C	A	B	B	C	B
d_A, Approach Delay [s/veh]	9.55		17.08		15.75	
Approach LOS	A		B		B	
d_I, Intersection Delay [s/veh]	13.34					
Intersection LOS	B					
Intersection V/C	0.625					

**Emissions**

Vehicle Miles Traveled [mph]	49.90	180.29	85.96	85.96	4.05	19.82
Stops [stops/h]	237.69	213.22	375.50	386.62	47.20	173.42
Fuel consumption [US gal/h]	6.40	10.04	8.94	9.15	0.68	2.49
CO [g/h]	447.20	701.84	625.21	639.57	47.53	173.81
NOx [g/h]	87.01	136.55	121.64	124.44	9.25	33.82
VOC [g/h]	103.64	162.66	144.90	148.23	11.01	40.28

**Other Modes**

g_Walk,mi, Effective Walk Time [s]	0.0		0.0		8.0	
M_corner, Corner Circulation Area [ft <sup>2</sup> /ped]	0.00		0.00		0.00	
M_CW, Crosswalk Circulation Area [ft <sup>2</sup> /ped]	0.00		0.00		0.00	
d_p, Pedestrian Delay [s]	0.00		0.00		24.80	
I_p,int, Pedestrian LOS Score for Intersectio	0.000		0.000		2.551	
Crosswalk LOS	F		F		B	
s_b, Saturation Flow Rate of the bicycle lane	2000		2000		2000	
c_b, Capacity of the bicycle lane [bicycles/h]	1991		1217		944	
d_b, Bicycle Delay [s]	0.00		4.96		9.00	
I_b,int, Bicycle LOS Score for Intersection	2.808		2.616		1.560	
Bicycle LOS	C		B		A	

**Sequence**

Ring 1	-	2	3	4	-	-	-	-	-	-	-	-	-	-	-	-
Ring 2	-	-	-	8	-	-	-	-	-	-	-	-	-	-	-	-
Ring 3	-	-	-	-	-	-	-	-	-	-	-	-	-	-	-	-
Ring 4	-	-	-	-	-	-	-	-	-	-	-	-	-	-	-	-

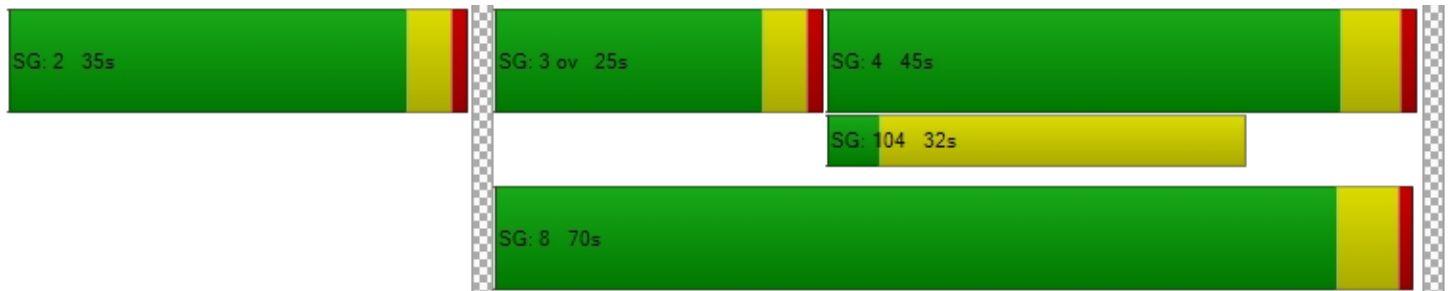

**Intersection Level Of Service Report**  
**Intersection 11: Fallon Road & I-580 WB Ramps**

Control Type:	Signalized	Delay (sec / veh):	26.5
Analysis Method:	HCM 7th Edition	Level Of Service:	C
Analysis Period:	15 minutes	Volume to Capacity (v/c):	0.594

**Intersection Setup**

Name	Fallon Road			Fallon Road			I-580 WB On-Ramp			I-580 WB Off-Ramp		
Approach	Northbound			Southbound			Eastbound			Westbound		
Lane Configuration	↑			↑↑↑						↑↑↑		
Turning Movement	Left	Thru	Right	Left	Thru	Right	Left	Thru	Right	Left	Thru	Right
Lane Width [ft]	12.00	12.00	12.00	12.00	12.00	12.00	12.00	12.00	12.00	12.00	12.00	12.00
No. of Lanes in Entry Pocket	0	0	0	0	0	1	0	0	0	1	0	1
Entry Pocket Length [ft]	100.00	100.00	100.00	100.00	100.00	225.00	100.00	100.00	100.00	170.00	100.00	130.00
No. of Lanes in Exit Pocket	0	0	1	0	0	0	0	0	1	0	0	0
Exit Pocket Length [ft]	0.00	0.00	400.00	0.00	0.00	0.00	0.00	0.00	400.00	0.00	0.00	0.00
Speed [mph]	45.00			40.00			30.00			35.00		
Grade [%]	0.00			0.00			0.00			0.00		
Curb Present	No			No						No		
Crosswalk	No			No			No			No		



**Volumes**

Name	Fallon Road			Fallon Road			I-580 WB On-Ramp			I-580 WB Off-Ramp		
Base Volume Input [veh/h]	0	862	0	0	1049	634	0	0	0	285	3	598
Base Volume Adjustment Factor	1.0000	1.0000	1.0000	1.0000	1.0000	1.0000	1.0000	1.0000	1.0000	1.0000	1.0000	1.0000
Heavy Vehicles Percentage [%]	2.00	0.10	2.00	2.00	0.60	1.00	2.00	2.00	2.00	0.80	0.00	1.50
Proportion of CAVs [%]	0.00											
Growth Factor	1.0000	1.0000	1.0000	1.0000	1.0000	1.0000	1.0000	1.0000	1.0000	1.0000	1.0000	1.0000
In-Process Volume [veh/h]	0	0	0	0	0	0	0	0	0	0	0	0
Site-Generated Trips [veh/h]	0	0	0	0	0	0	0	0	0	0	0	0
Diverted Trips [veh/h]	0	0	0	0	0	0	0	0	0	0	0	0
Pass-by Trips [veh/h]	0	0	0	0	0	0	0	0	0	0	0	0
Existing Site Adjustment Volume [veh/h]	0	0	0	0	0	0	0	0	0	0	0	0
Other Volume [veh/h]	0	0	0	0	0	0	0	0	0	0	0	0
Right Turn on Red Volume [veh/h]	0	0	0	0	0	0	0	0	0	0	0	0
Total Hourly Volume [veh/h]	0	862	0	0	1049	634	0	0	0	285	3	598
Peak Hour Factor	1.0000	0.9500	1.0000	1.0000	0.9500	0.9500	1.0000	1.0000	1.0000	0.9500	0.9500	0.9500
Other Adjustment Factor	1.0000	1.0000	1.0000	1.0000	1.0000	1.0000	1.0000	1.0000	1.0000	1.0000	1.0000	1.0000
Total 15-Minute Volume [veh/h]	0	227	0	0	276	167	0	0	0	75	1	157
Total Analysis Volume [veh/h]	0	907	0	0	1104	667	0	0	0	300	3	629
Presence of On-Street Parking	No		No	No		No				No		No
On-Street Parking Maneuver Rate [/h]	0	0	0	0	0	0	0	0	0	0	0	0
Local Bus Stopping Rate [/h]	0	0	0	0	0	0	0	0	0	0	0	0
v_do, Outbound Pedestrian Volume crossing	0			0			0			0		
v_di, Inbound Pedestrian Volume crossing m	0			0			0			0		
v_co, Outbound Pedestrian Volume crossing	0			0			0			0		
v_ci, Inbound Pedestrian Volume crossing mi	0			0			0			0		
v_ab, Corner Pedestrian Volume [ped/h]	0			0			0			0		
Bicycle Volume [bicycles/h]	0			0			0			0		



**Intersection Settings**

Located in CBD	No
Signal Coordination Group	-
Cycle Length [s]	90
Active Pattern	Free Running (No Pattern)
Coordination Type	<i>Free Running</i>
Actuation Type	<i>Fully actuated</i>
Offset [s]	0.0
Offset Reference	Lead Green - Beginning of First Green
Permissive Mode	SingleBand
Lost time [s]	9.00

**Phasing & Timing (Basic)**

Control Type	Permiss	Permiss	Permiss	Permiss	Permiss	Permiss	Permiss	Permiss	Permiss	Permiss	Permiss	Overlap
Signal Group	0	2	0	0	6	0	0	0	0	0	8	1
Auxiliary Signal Groups												1,8
Maximum Green [s]	0	35	0	0	35	0	0	0	0	0	20	15
Amber [s]	0.0	4.8	0.0	0.0	4.8	0.0	0.0	0.0	0.0	0.0	3.7	3.7
All red [s]	0.0	0.5	0.0	0.0	0.5	0.0	0.0	0.0	0.0	0.0	0.5	0.5
Walk [s]	0	0	0	0	0	0	0	0	0	0	0	0
Pedestrian Clearance [s]	0	0	0	0	0	0	0	0	0	0	0	0
Delayed Vehicle Green [s]	0.0	0.0	0.0	0.0	0.0	0.0	0.0	0.0	0.0	0.0	0.0	0.0
Rest In Walk		No			No						No	
I1, Start-Up Lost Time [s]	0.0	2.0	0.0	0.0	2.0	0.0	0.0	0.0	0.0	0.0	2.0	2.0
I2, Clearance Lost Time [s]	0.0	3.3	0.0	0.0	3.3	0.0	0.0	0.0	0.0	0.0	2.2	2.2
Detector Location [ft]	0.0	0.0	0.0	0.0	0.0	0.0	0.0	0.0	0.0	0.0	0.0	0.0
Detector Length [ft]	0.0	20.0	0.0	0.0	20.0	0.0	0.0	0.0	0.0	0.0	20.0	20.0
I, Upstream Filtering Factor	1.00	1.00	1.00	1.00	1.00	1.00	1.00	1.00	1.00	1.00	1.00	1.00

**Phasing & Timing: Free Running (No Pattern)**

Split [s]	0	0	0	0	0	0	0	0	0	0	0	0
Lead / Lag	-	-	-	-	-	-	-	-	-	-	-	-
Minimum Green [s]	0	10	0	0	10	0	0	0	0	0	5	4
Vehicle Extension [s]	0.0	0.0	0.0	0.0	0.0	0.0	0.0	0.0	0.0	0.0	0.0	0.0
Minimum Recall		Yes			Yes						No	No
Maximum Recall		No			No						No	No
Pedestrian Recall		No			No						No	No

**Exclusive Pedestrian Phase**

Pedestrian Signal Group	0
Pedestrian Walk [s]	0
Pedestrian Clearance [s]	0



**Lane Group Calculations**

Lane Group	C	C	R		L	C	R
C, Cycle Length [s]	78	78	78		78	78	78
L, Total Lost Time per Cycle [s]	5.30	5.30	5.30		4.20	4.20	4.20
l1_p, Permitted Start-Up Lost Time [s]	0.00	0.00	0.00		0.00	0.00	0.00
l2, Clearance Lost Time [s]	3.30	3.30	3.30		2.20	2.20	0.00
g_i, Effective Green Time [s]	35	54	54		15	15	34
g / C, Green / Cycle	0.45	0.69	0.69		0.19	0.19	0.43
(v / s)_i Volume / Saturation Flow Rate	0.48	0.31	0.42		0.08	0.08	0.22
s, saturation flow rate [veh/h]	1898	3600	1602		1798	1811	2825
c, Capacity [veh/h]	849	2483	1105		340	342	1218
d1, Uniform Delay [s]	21.62	5.44	6.46		28.09	28.08	16.28
k, delay calibration	0.48	0.04	0.36		0.04	0.04	0.05
l, Upstream Filtering Factor	1.00	1.00	1.00		1.00	1.00	1.00
d2, Incremental Delay [s]	50.07	0.05	1.78		0.34	0.34	0.14
d3, Initial Queue Delay [s]	0.00	0.00	0.00		0.00	0.00	0.00
Rp, platoon ratio	1.00	1.00	1.00		1.00	1.00	1.00
PF, progression factor	1.00	1.00	1.00		1.00	1.00	1.00

**Lane Group Results**

X, volume / capacity	1.07	0.44	0.60		0.44	0.44	0.52
d, Delay for Lane Group [s/veh]	71.69	5.49	8.24		28.42	28.42	16.42
Lane Group LOS	F	A	A		C	C	B
Critical Lane Group	Yes	No	No		No	No	Yes
50th-Percentile Queue Length [veh/ln]	24.78	2.73	4.44		2.42	2.44	3.77
50th-Percentile Queue Length [ft/ln]	619.55	68.18	110.95		60.62	61.00	94.18
95th-Percentile Queue Length [veh/ln]	34.58	4.91	7.89		4.36	4.39	6.78
95th-Percentile Queue Length [ft/ln]	864.51	122.72	197.32		109.11	109.80	169.52



**Movement, Approach, & Intersection Results**

d_M, Delay for Movement [s/veh]	0.00	71.69	0.00	0.00	5.49	8.24	0.00	0.00	0.00	28.42	28.42	16.42
Movement LOS		F			A	A				C	C	B
d_A, Approach Delay [s/veh]	71.69		6.52			0.00			20.32			
Approach LOS	E		A			A			C			
d_I, Intersection Delay [s/veh]	26.46											
Intersection LOS	C											
Intersection V/C	0.594											

**Emissions**

Vehicle Miles Traveled [mph]	94.53	167.97	101.48		21.91	22.05	91.25
Stops [stops/h]	1140.50	251.00	204.25		111.58	112.29	346.74
Fuel consumption [US gal/h]	30.65	9.72	6.76		2.55	2.56	8.19
CO [g/h]	2142.60	679.10	472.57		178.08	179.22	572.36
NOx [g/h]	416.87	132.13	91.94		34.65	34.87	111.36
VOC [g/h]	496.57	157.39	109.52		41.27	41.54	132.65

**Other Modes**

g_Walk,mi, Effective Walk Time [s]	0.0	0.0	0.0	0.0
M_corner, Corner Circulation Area [ft <sup>2</sup> /ped]	0.00	0.00	0.00	0.00
M_CW, Crosswalk Circulation Area [ft <sup>2</sup> /ped]	0.00	0.00	0.00	0.00
d_p, Pedestrian Delay [s]	0.00	0.00	0.00	0.00
I_p,int, Pedestrian LOS Score for Intersectio	0.000	0.000	0.000	0.000
Crosswalk LOS	F	F	F	F
s_b, Saturation Flow Rate of the bicycle lane	2000	2000	2000	2000
c_b, Capacity of the bicycle lane [bicycles/h]	895	895	0	511
d_b, Bicycle Delay [s]	11.94	11.94	39.11	21.67
I_b,int, Bicycle LOS Score for Intersection	3.056	3.021	4.132	3.097
Bicycle LOS	C	C	D	C

**Sequence**

Ring 1	1	2	-	-	-	-	-	-	-	-	-	-	-	-	-
Ring 2	-	6	-	8	-	-	-	-	-	-	-	-	-	-	-
Ring 3	-	-	-	-	-	-	-	-	-	-	-	-	-	-	-
Ring 4	-	-	-	-	-	-	-	-	-	-	-	-	-	-	-



**Intersection Level Of Service Report**  
**Intersection 12: El Charro Road & I-580 EB Ramps**

Control Type:	Signalized	Delay (sec / veh):	7.2
Analysis Method:	HCM 7th Edition	Level Of Service:	A
Analysis Period:	15 minutes	Volume to Capacity (v/c):	0.605

**Intersection Setup**

Name	El Charro Road			Fallon Road			I-580 EB Off-Ramp			I-580 EB On-Ramp		
Approach	Northbound			Southbound			Eastbound			Westbound		
Lane Configuration	↑↑			↑↑			↵↵↵↵					
Turning Movement	Left	Thru	Right	Left	Thru	Right	Left	Thru	Right	Left	Thru	Right
Lane Width [ft]	12.00	12.00	12.00	12.00	12.00	12.00	12.00	12.00	12.00	12.00	12.00	12.00
No. of Lanes in Entry Pocket	0	0	0	1	0	0	1	0	1	0	0	0
Entry Pocket Length [ft]	100.00	100.00	100.00	135.00	100.00	100.00	350.00	100.00	350.00	100.00	100.00	100.00
No. of Lanes in Exit Pocket	0	0	0	0	0	1	0	0	0	0	0	0
Exit Pocket Length [ft]	0.00	0.00	0.00	0.00	0.00	100.00	0.00	0.00	0.00	0.00	0.00	0.00
Speed [mph]	30.00			40.00			35.00			30.00		
Grade [%]	0.00			0.00			0.00			0.00		
Curb Present	No			No			No					
Crosswalk	No			No			No			Yes		



**Volumes**

Name	El Charro Road			Fallon Road			I-580 EB Off-Ramp			I-580 EB On-Ramp		
Base Volume Input [veh/h]	0	882	0	0	824	0	402	0	362	0	0	0
Base Volume Adjustment Factor	1.0000	1.0000	1.0000	1.0000	1.0000	1.0000	1.0000	1.0000	1.0000	1.0000	1.0000	1.0000
Heavy Vehicles Percentage [%]	2.00	0.80	2.00	2.00	0.40	2.00	0.30	2.00	1.80	2.00	2.00	2.00
Proportion of CAVs [%]	0.00											
Growth Factor	1.0000	1.0000	1.0000	1.0000	1.0000	1.0000	1.0000	1.0000	1.0000	1.0000	1.0000	1.0000
In-Process Volume [veh/h]	0	0	0	0	0	0	0	0	0	0	0	0
Site-Generated Trips [veh/h]	0	0	0	0	0	0	0	0	0	0	0	0
Diverted Trips [veh/h]	0	0	0	0	0	0	0	0	0	0	0	0
Pass-by Trips [veh/h]	0	0	0	0	0	0	0	0	0	0	0	0
Existing Site Adjustment Volume [veh/h]	0	0	0	0	0	0	0	0	0	0	0	0
Other Volume [veh/h]	0	0	0	0	0	0	0	0	0	0	0	0
Right Turn on Red Volume [veh/h]	0	0	0	0	0	0	0	0	0	0	0	0
Total Hourly Volume [veh/h]	0	882	0	0	824	0	402	0	362	0	0	0
Peak Hour Factor	1.0000	0.9600	1.0000	1.0000	0.9600	1.0000	0.9600	1.0000	0.9600	1.0000	1.0000	1.0000
Other Adjustment Factor	1.0000	1.0000	1.0000	1.0000	1.0000	1.0000	1.0000	1.0000	1.0000	1.0000	1.0000	1.0000
Total 15-Minute Volume [veh/h]	0	230	0	0	215	0	105	0	94	0	0	0
Total Analysis Volume [veh/h]	0	919	0	0	858	0	419	0	377	0	0	0
Presence of On-Street Parking	No		No	No		No	No		No			
On-Street Parking Maneuver Rate [/h]	0	0	0	0	0	0	0	0	0	0	0	0
Local Bus Stopping Rate [/h]	0	0	0	0	0	0	0	0	0	0	0	0
v_do, Outbound Pedestrian Volume crossing	0			0			0			0		
v_di, Inbound Pedestrian Volume crossing m	0			0			0			0		
v_co, Outbound Pedestrian Volume crossing	0			0			0			0		
v_ci, Inbound Pedestrian Volume crossing mi	0			0			0			0		
v_ab, Corner Pedestrian Volume [ped/h]	0			0			0			0		
Bicycle Volume [bicycles/h]	0			0			0			0		





**Intersection Settings**

Located in CBD	No
Signal Coordination Group	-
Cycle Length [s]	90
Active Pattern	Free Running (No Pattern)
Coordination Type	<i>Free Running</i>
Actuation Type	<i>Fully actuated</i>
Offset [s]	0.0
Offset Reference	Lead Green - Beginning of First Green
Permissive Mode	SingleBand
Lost time [s]	9.00

**Phasing & Timing (Basic)**

Control Type	Permiss	Permiss	Permiss	Permiss	Permiss	Permiss	Permiss	Permiss	Permiss	Permiss	Permiss	Permiss
Signal Group	0	2	0	0	6	0	4	0	0	0	0	0
Auxiliary Signal Groups												
Maximum Green [s]	0	40	0	0	40	0	26	0	0	0	0	0
Amber [s]	0.0	4.8	0.0	0.0	4.8	0.0	3.7	0.0	0.0	0.0	0.0	0.0
All red [s]	0.0	1.0	0.0	0.0	1.0	0.0	0.5	0.0	0.0	0.0	0.0	0.0
Walk [s]	0	0	0	0	0	0	0	0	0	0	0	0
Pedestrian Clearance [s]	0	0	0	0	0	0	0	0	0	0	0	0
Delayed Vehicle Green [s]	0.0	0.0	0.0	0.0	0.0	0.0	0.0	0.0	0.0	0.0	0.0	0.0
Rest In Walk		No			No		No					
I1, Start-Up Lost Time [s]	0.0	2.0	0.0	0.0	2.0	0.0	2.0	0.0	0.0	0.0	0.0	0.0
I2, Clearance Lost Time [s]	0.0	3.3	0.0	0.0	3.3	0.0	2.7	0.0	0.0	0.0	0.0	0.0
Detector Location [ft]	0.0	0.0	0.0	0.0	0.0	0.0	0.0	0.0	0.0	0.0	0.0	0.0
Detector Length [ft]	0.0	0.0	0.0	0.0	0.0	0.0	0.0	0.0	0.0	0.0	0.0	0.0
I, Upstream Filtering Factor	1.00	1.00	1.00	1.00	1.00	1.00	1.00	1.00	1.00	1.00	1.00	1.00

**Phasing & Timing: Free Running (No Pattern)**

Split [s]	0	0	0	0	0	0	0	0	0	0	0	0
Lead / Lag	-	-	-	-	-	-	Lead	-	-	-	-	-
Minimum Green [s]	0	10	0	0	10	0	4	0	0	0	0	0
Vehicle Extension [s]	0.0	0.0	0.0	0.0	0.0	0.0	0.0	0.0	0.0	0.0	0.0	0.0
Minimum Recall		Yes			Yes		No					
Maximum Recall		No			No		No					
Pedestrian Recall		No			No		No					

**Exclusive Pedestrian Phase**

Pedestrian Signal Group	0
Pedestrian Walk [s]	0
Pedestrian Clearance [s]	0



**Lane Group Calculations**

Lane Group	C	C	L	R	
C, Cycle Length [s]	25	25	25	25	
L, Total Lost Time per Cycle [s]	5.30	5.30	4.70	4.70	
l1_p, Permitted Start-Up Lost Time [s]	0.00	0.00	0.00	0.00	
l2, Clearance Lost Time [s]	3.30	3.30	2.70	2.70	
g_i, Effective Green Time [s]	11	11	5	5	
g / C, Green / Cycle	0.42	0.42	0.19	0.19	
(v / s)_i Volume / Saturation Flow Rate	0.26	0.24	0.12	0.13	
s, saturation flow rate [veh/h]	3595	3606	3506	2818	
c, Capacity [veh/h]	1497	1502	664	534	
d1, Uniform Delay [s]	5.80	5.67	9.47	9.63	
k, delay calibration	0.04	0.04	0.04	0.04	
l, Upstream Filtering Factor	1.00	1.00	1.00	1.00	
d2, Incremental Delay [s]	0.15	0.13	0.37	0.65	
d3, Initial Queue Delay [s]	0.00	0.00	0.00	0.00	
Rp, platoon ratio	1.00	1.00	1.00	1.00	
PF, progression factor	1.00	1.00	1.00	1.00	

**Lane Group Results**

X, volume / capacity	0.61	0.57	0.63	0.71	
d, Delay for Lane Group [s/veh]	5.95	5.79	9.84	10.27	
Lane Group LOS	A	A	A	B	
Critical Lane Group	Yes	No	No	Yes	
50th-Percentile Queue Length [veh/ln]	0.78	0.45	0.65	0.61	
50th-Percentile Queue Length [ft/ln]	19.43	11.28	16.27	15.30	
95th-Percentile Queue Length [veh/ln]	1.40	0.81	1.17	1.10	
95th-Percentile Queue Length [ft/ln]	34.98	20.31	29.28	27.53	

**Movement, Approach, & Intersection Results**

d_M, Delay for Movement [s/veh]	0.00	5.95	0.00	0.00	5.79	0.00	9.84	0.00	10.27	0.00	0.00	0.00
Movement LOS		A			A		A		B			
d_A, Approach Delay [s/veh]	5.95				5.79		10.04		0.00			
Approach LOS	A				A		B		A			
d_I, Intersection Delay [s/veh]	7.17											
Intersection LOS	A											
Intersection V/C	0.605											

**Emissions**

Vehicle Miles Traveled [mph]	158.21	84.27	48.69	43.81
Stops [stops/h]	221.59	128.63	185.49	174.40
Fuel consumption [US gal/h]	8.85	5.29	4.09	3.77
CO [g/h]	618.68	370.05	285.89	263.49
NOx [g/h]	120.37	72.00	55.62	51.27
VOC [g/h]	143.38	85.76	66.26	61.07

**Other Modes**

g_Walk,mi, Effective Walk Time [s]	0.0	0.0	0.0	-5.8
M_corner, Corner Circulation Area [ft <sup>2</sup> /ped]	0.00	0.00	0.00	0.00
M_CW, Crosswalk Circulation Area [ft <sup>2</sup> /ped]	0.00	0.00	0.00	0.00
d_p, Pedestrian Delay [s]	0.00	0.00	0.00	19.10
I_p,int, Pedestrian LOS Score for Intersectio	0.000	0.000	0.000	1.690
Crosswalk LOS	F	F	F	A
s_b, Saturation Flow Rate of the bicycle lane	2000	2000	2000	2000
c_b, Capacity of the bicycle lane [bicycles/h]	3167	3167	2059	0
d_b, Bicycle Delay [s]	4.30	4.30	0.01	12.63
I_b,int, Bicycle LOS Score for Intersection	2.318	2.267	1.560	4.132
Bicycle LOS	B	B	A	D

**Sequence**

Ring 1	-	2	-	4	-	-	-	-	-	-	-	-	-	-	-
Ring 2	-	6	-	-	-	-	-	-	-	-	-	-	-	-	-
Ring 3	-	-	-	-	-	-	-	-	-	-	-	-	-	-	-
Ring 4	-	-	-	-	-	-	-	-	-	-	-	-	-	-	-



**Intersection Level Of Service Report**  
**Intersection 13: El Charro Road & Jack London Boulevard**

Control Type:	Signalized	Delay (sec / veh):	13.9
Analysis Method:	HCM 7th Edition	Level Of Service:	B
Analysis Period:	15 minutes	Volume to Capacity (v/c):	0.719

**Intersection Setup**

Name	El Charro Road			El Charro Road			Stoneridge Drive			Jack London Boulevard		
Approach	Northbound			Southbound			Eastbound			Westbound		
Lane Configuration	TUT			TUT			TUT			TUT		
Turning Movement	Left	Thru	Right	Left	Thru	Right	Left	Thru	Right	Left	Thru	Right
Lane Width [ft]	12.00	12.00	12.00	12.00	12.00	12.00	12.00	12.00	12.00	12.00	12.00	12.00
No. of Lanes in Entry Pocket	1	0	2	2	0	1	3	0	1	1	0	2
Entry Pocket Length [ft]	125.00	100.00	175.00	650.00	100.00	450.00	450.00	100.00	325.00	400.00	100.00	775.00
No. of Lanes in Exit Pocket	0	0	0	0	0	2	1	0	0	0	0	0
Exit Pocket Length [ft]	0.00	0.00	0.00	0.00	0.00	100.00	450.00	0.00	0.00	0.00	0.00	0.00
Speed [mph]	30.00			30.00			30.00			30.00		
Grade [%]	0.00			0.00			0.00			0.00		
Curb Present	Yes			Yes			Yes			Yes		
Crosswalk	Yes			No			Yes			Yes		



**Volumes**

Name	El Charro Road			El Charro Road			Stoneridge Drive			Jack London Boulevard		
Base Volume Input [veh/h]	34	102	77	734	77	388	615	433	52	29	168	650
Base Volume Adjustment Factor	1.0000	1.0000	1.0000	1.0000	1.0000	1.0000	1.0000	1.0000	1.0000	1.0000	1.0000	1.0000
Heavy Vehicles Percentage [%]	0.00	20.00	0.00	0.30	44.40	0.80	0.50	0.50	0.00	0.00	1.80	0.60
Proportion of CAVs [%]	0.00											
Growth Factor	1.0000	1.0000	1.0000	1.0000	1.0000	1.0000	1.0000	1.0000	1.0000	1.0000	1.0000	1.0000
In-Process Volume [veh/h]	0	0	0	0	0	0	0	0	0	0	0	0
Site-Generated Trips [veh/h]	0	0	0	0	0	0	0	0	0	0	0	0
Diverted Trips [veh/h]	0	0	0	0	0	0	0	0	0	0	0	0
Pass-by Trips [veh/h]	0	0	0	0	0	0	0	0	0	0	0	0
Existing Site Adjustment Volume [veh/h]	0	0	0	0	0	0	0	0	0	0	0	0
Other Volume [veh/h]	0	0	0	0	0	0	0	0	0	0	0	0
Right Turn on Red Volume [veh/h]	0	0	0	0	0	0	0	0	0	0	0	0
Total Hourly Volume [veh/h]	34	102	77	734	77	388	615	433	52	29	168	650
Peak Hour Factor	0.9200	0.9200	0.9200	0.9200	0.9200	0.9200	0.9200	0.9200	0.9200	0.9200	0.9200	0.9200
Other Adjustment Factor	1.0000	1.0000	1.0000	1.0000	1.0000	1.0000	1.0000	1.0000	1.0000	1.0000	1.0000	1.0000
Total 15-Minute Volume [veh/h]	9	28	21	199	21	105	167	118	14	8	46	177
Total Analysis Volume [veh/h]	37	111	84	798	84	422	668	471	57	32	183	707
Presence of On-Street Parking	No		No	No		No	No		No	No		No
On-Street Parking Maneuver Rate [/h]	0	0	0	0	0	0	0	0	0	0	0	0
Local Bus Stopping Rate [/h]	0	0	0	0	0	0	0	0	0	0	0	0
v_do, Outbound Pedestrian Volume crossing	0			0			0			0		
v_di, Inbound Pedestrian Volume crossing m	0			0			0			0		
v_co, Outbound Pedestrian Volume crossing	0			0			0			0		
v_ci, Inbound Pedestrian Volume crossing mi	0			0			0			0		
v_ab, Corner Pedestrian Volume [ped/h]	0			0			0			0		
Bicycle Volume [bicycles/h]	0			0			0			0		



**Intersection Settings**

Located in CBD	No
Signal Coordination Group	-
Cycle Length [s]	90
Active Pattern	Free Running (No Pattern)
Coordination Type	<i>Free Running</i>
Actuation Type	<i>Fully actuated</i>
Offset [s]	0.0
Offset Reference	Lead Green - Beginning of First Green
Permissive Mode	SingleBand
Lost time [s]	12.00

**Phasing & Timing (Basic)**

Control Type	ProtPer	Permiss	Permiss	Protecte	Permiss	Permiss	ProtPer	Permiss	Permiss	ProtPer	Permiss	Overlap
Signal Group	7	4	0	3	8	0	1	6	0	5	2	2
Auxiliary Signal Groups												2,3
Maximum Green [s]	5	25	0	35	20	0	4	25	0	7	20	20
Amber [s]	3.0	5.0	0.0	3.0	4.3	0.0	3.0	4.3	0.0	3.0	4.3	4.3
All red [s]	1.0	1.0	0.0	1.0	1.0	0.0	1.0	1.0	0.0	1.0	1.0	1.0
Walk [s]	0	5	0	0	5	0	0	5	0	0	0	0
Pedestrian Clearance [s]	0	28	0	0	28	0	0	30	0	0	0	0
Delayed Vehicle Green [s]	0.0	0.0	0.0	0.0	0.0	0.0	0.0	0.0	0.0	0.0	0.0	0.0
Rest In Walk		No			No			No			No	
I1, Start-Up Lost Time [s]	2.0	2.0	0.0	2.0	2.0	0.0	2.0	2.0	0.0	2.0	2.0	2.0
I2, Clearance Lost Time [s]	2.0	2.0	0.0	2.0	2.0	0.0	2.0	2.0	0.0	2.0	2.0	2.0
Detector Location [ft]	0.0	0.0	0.0	0.0	0.0	0.0	0.0	0.0	0.0	0.0	0.0	0.0
Detector Length [ft]	0.0	0.0	0.0	0.0	0.0	0.0	0.0	0.0	0.0	0.0	0.0	0.0
I, Upstream Filtering Factor	1.00	1.00	1.00	1.00	1.00	1.00	1.00	1.00	1.00	1.00	1.00	1.00

**Phasing & Timing: Free Running (No Pattern)**

Split [s]	0	0	0	0	0	0	0	0	0	0	0	0
Lead / Lag	Lead	-	-	Lead	-	-	Lead	-	-	Lead	-	-
Minimum Green [s]	4	5	0	7	5	0	5	4	0	4	7	7
Vehicle Extension [s]	2.0	2.5	0.0	2.5	2.5	0.0	2.0	3.0	0.0	2.0	3.0	3.0
Minimum Recall	Yes	No		No	No		Yes	Yes		Yes	Yes	Yes
Maximum Recall	No	No		No	No		No	No		No	No	No
Pedestrian Recall	No	No		No	No		No	No		No	No	No

**Exclusive Pedestrian Phase**

Pedestrian Signal Group	0
Pedestrian Walk [s]	0
Pedestrian Clearance [s]	0



**Lane Group Calculations**

Lane Group	L	C	C	L	C	R	L	C	R	L	C	R
C, Cycle Length [s]	50	50	50	50	50	50	50	50	50	50	50	50
L, Total Lost Time per Cycle [s]	4.00	4.00	4.00	4.00	4.00	4.00	4.00	4.00	4.00	4.00	4.00	4.00
l1_p, Permitted Start-Up Lost Time [s]	0.00	0.00	0.00	0.00	0.00	0.00	0.00	0.00	0.00	0.00	0.00	0.00
l2, Clearance Lost Time [s]	0.00	2.00	2.00	2.00	2.00	2.00	0.00	2.00	2.00	0.00	2.00	0.00
g_i, Effective Green Time [s]	25	7	7	14	19	19	17	11	11	17	9	27
g / C, Green / Cycle	0.50	0.14	0.14	0.28	0.39	0.39	0.34	0.23	0.23	0.34	0.18	0.54
(v / s)_i Volume / Saturation Flow Rate	0.04	0.04	0.06	0.15	0.07	0.26	0.22	0.13	0.04	0.03	0.05	0.25
s, saturation flow rate [veh/h]	883	3046	1360	5259	1234	1605	3049	3603	1615	1077	3566	2845
c, Capacity [veh/h]	741	421	188	1494	481	625	1311	825	370	479	637	1543
d1, Uniform Delay [s]	7.49	19.31	19.83	15.13	10.02	12.66	13.64	17.13	15.44	12.40	17.82	6.98
k, delay calibration	0.08	0.08	0.08	0.08	0.08	0.16	0.14	0.11	0.11	0.11	0.11	0.11
l, Upstream Filtering Factor	1.00	1.00	1.00	1.00	1.00	1.00	1.00	1.00	1.00	1.00	1.00	1.00
d2, Incremental Delay [s]	0.02	0.25	1.23	0.22	0.13	1.93	0.40	0.62	0.19	0.06	0.25	0.21
d3, Initial Queue Delay [s]	0.00	0.00	0.00	0.00	0.00	0.00	0.00	0.00	0.00	0.00	0.00	0.00
Rp, platoon ratio	1.00	1.00	1.00	1.00	1.00	1.00	1.00	1.00	1.00	1.00	1.00	1.00
PF, progression factor	1.00	1.00	1.00	1.00	1.00	1.00	1.00	1.00	1.00	1.00	1.00	1.00

**Lane Group Results**

X, volume / capacity	0.05	0.26	0.45	0.53	0.17	0.67	0.51	0.57	0.15	0.07	0.29	0.46
d, Delay for Lane Group [s/veh]	7.51	19.56	21.07	15.36	10.14	14.59	14.04	17.75	15.63	12.46	18.07	7.19
Lane Group LOS	A	B	C	B	B	B	B	B	B	B	B	A
Critical Lane Group	Yes	No	No	No	No	Yes	Yes	No	No	No	No	Yes
50th-Percentile Queue Length [veh/ln]	0.18	0.54	0.88	2.24	0.52	3.53	1.75	2.19	0.48	0.22	0.84	1.68
50th-Percentile Queue Length [ft/ln]	4.43	13.42	21.92	55.99	13.01	88.30	43.71	54.72	12.04	5.62	21.09	41.97
95th-Percentile Queue Length [veh/ln]	0.32	0.97	1.58	4.03	0.94	6.36	3.15	3.94	0.87	0.40	1.52	3.02
95th-Percentile Queue Length [ft/ln]	7.97	24.16	39.45	100.78	23.42	158.94	78.68	98.50	21.66	10.11	37.97	75.54



**Movement, Approach, & Intersection Results**

d_M, Delay for Movement [s/veh]	7.51	19.56	21.07	15.36	10.14	14.59	14.04	17.75	15.63	12.46	18.07	7.19
Movement LOS	A	B	C	B	B	B	B	B	B	B	B	A
d_A, Approach Delay [s/veh]	18.18			14.77			15.58			9.53		
Approach LOS	B			B			B			A		
d_I, Intersection Delay [s/veh]	13.93											
Intersection LOS	B											
Intersection V/C	0.719											

**Emissions**

Vehicle Miles Traveled [mph]	2.35	7.04	5.33	137.38	14.46	72.65	85.28	60.13	7.28	5.56	31.79	122.83
Stops [stops/h]	12.77	77.43	63.22	484.47	37.52	254.67	378.20	315.65	34.71	16.20	121.68	242.08
Fuel consumption [US gal/h]	0.22	1.16	0.93	10.83	0.98	5.65	7.51	5.92	0.67	0.40	2.65	7.43
CO [g/h]	15.64	81.05	64.93	756.73	68.22	394.99	524.90	413.89	47.02	27.93	185.52	519.27
NOx [g/h]	3.04	15.77	12.63	147.23	13.27	76.85	102.13	80.53	9.15	5.43	36.09	101.03
VOC [g/h]	3.63	18.78	15.05	175.38	15.81	91.54	121.65	95.92	10.90	6.47	43.00	120.35

**Other Modes**

g_Walk,mi, Effective Walk Time [s]	9.0			0.0			9.0			9.0		
M_corner, Corner Circulation Area [ft <sup>2</sup> /ped]	0.00			0.00			0.00			0.00		
M_CW, Crosswalk Circulation Area [ft <sup>2</sup> /ped]	0.00			0.00			0.00			0.00		
d_p, Pedestrian Delay [s]	16.77			0.00			16.77			16.77		
I_p,int, Pedestrian LOS Score for Intersectio	2.361			0.000			3.041			2.973		
Crosswalk LOS	B			F			C			C		
s_b, Saturation Flow Rate of the bicycle lane	2000			2000			2000			2000		
c_b, Capacity of the bicycle lane [bicycles/h]	1001			801			1001			801		
d_b, Bicycle Delay [s]	6.22			8.97			6.22			8.97		
I_b,int, Bicycle LOS Score for Intersection	1.687			3.711			2.546			2.320		
Bicycle LOS	A			D			B			B		

**Sequence**

Ring 1	1	2	3	4	-	-	-	-	-	-	-	-	-	-	-
Ring 2	5	6	7	8	-	-	-	-	-	-	-	-	-	-	-
Ring 3	-	-	-	-	-	-	-	-	-	-	-	-	-	-	-
Ring 4	-	-	-	-	-	-	-	-	-	-	-	-	-	-	-

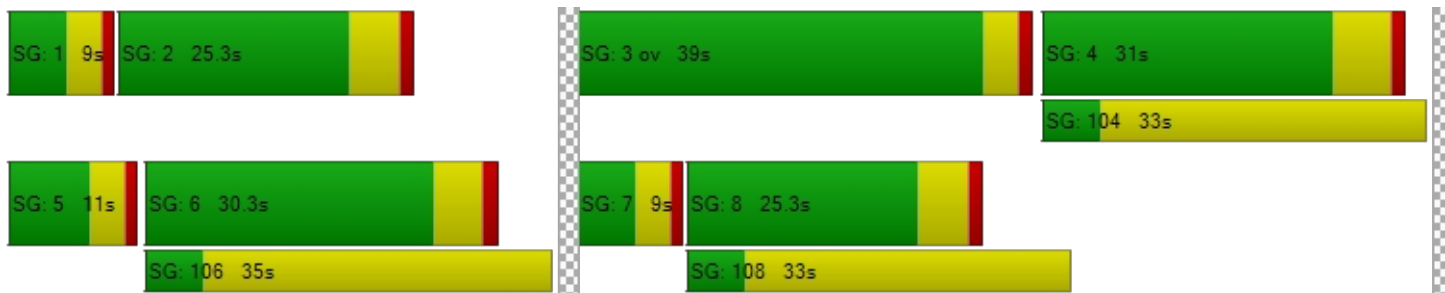



**Intersection Level Of Service Report**  
**Intersection 14: Central Parkway & Sunset View Drive**

Control Type:	Signalized	Delay (sec / veh):	11.2
Analysis Method:	HCM 7th Edition	Level Of Service:	B
Analysis Period:	15 minutes	Volume to Capacity (v/c):	0.307

**Intersection Setup**

Name	Driveway			Sunset View Drive			Central Parkway			Central Parkway		
Approach	Northbound			Southbound			Eastbound			Westbound		
Lane Configuration	↵↵			↵↵			↵↵↵			↵↵		
Turning Movement	Left	Thru	Right	Left	Thru	Right	Left	Thru	Right	Left	Thru	Right
Lane Width [ft]	12.00	12.00	12.00	12.00	12.00	12.00	12.00	12.00	12.00	12.00	12.00	12.00
No. of Lanes in Entry Pocket	1	0	0	0	0	1	1	0	1	1	0	0
Entry Pocket Length [ft]	250.00	100.00	100.00	100.00	100.00	85.00	225.00	100.00	800.00	150.00	100.00	100.00
No. of Lanes in Exit Pocket	0	0	0	0	0	0	0	0	0	0	0	0
Exit Pocket Length [ft]	0.00	0.00	0.00	0.00	0.00	0.00	0.00	0.00	0.00	0.00	0.00	0.00
Speed [mph]	30.00			30.00			30.00			30.00		
Grade [%]	0.00			0.00			0.00			0.00		
Curb Present	No			No			No			No		
Crosswalk	Yes			Yes			Yes			Yes		



**Volumes**

Name	Driveway			Sunset View Drive			Central Parkway			Central Parkway		
Base Volume Input [veh/h]	9	1	4	3	2	74	81	236	14	2	123	1
Base Volume Adjustment Factor	1.0000	1.0000	1.0000	1.0000	1.0000	1.0000	1.0000	1.0000	1.0000	1.0000	1.0000	1.0000
Heavy Vehicles Percentage [%]	0.00	0.00	0.00	0.00	0.00	0.00	0.00	0.00	0.00	0.00	0.00	0.00
Proportion of CAVs [%]	0.00											
Growth Factor	1.0000	1.0000	1.0000	1.0000	1.0000	1.0000	1.0000	1.0000	1.0000	1.0000	1.0000	1.0000
In-Process Volume [veh/h]	0	0	0	0	0	0	0	0	0	0	0	0
Site-Generated Trips [veh/h]	0	0	0	0	0	0	0	0	0	0	0	0
Diverted Trips [veh/h]	0	0	0	0	0	0	0	0	0	0	0	0
Pass-by Trips [veh/h]	0	0	0	0	0	0	0	0	0	0	0	0
Existing Site Adjustment Volume [veh/h]	0	0	0	0	0	0	0	0	0	0	0	0
Other Volume [veh/h]	0	0	0	0	0	0	0	0	0	0	0	0
Right Turn on Red Volume [veh/h]	0	0	0	0	0	0	0	0	0	0	0	0
Total Hourly Volume [veh/h]	9	1	4	3	2	74	81	236	14	2	123	1
Peak Hour Factor	0.9200	0.9200	0.9200	0.9200	0.9200	0.9200	0.9200	0.9200	0.9200	0.9200	0.9200	0.9200
Other Adjustment Factor	1.0000	1.0000	1.0000	1.0000	1.0000	1.0000	1.0000	1.0000	1.0000	1.0000	1.0000	1.0000
Total 15-Minute Volume [veh/h]	2	0	1	1	1	20	22	64	4	1	33	0
Total Analysis Volume [veh/h]	10	1	4	3	2	80	88	257	15	2	134	1
Presence of On-Street Parking	No		No	No		No	No		No	No		No
On-Street Parking Maneuver Rate [/h]	0	0	0	0	0	0	0	0	0	0	0	0
Local Bus Stopping Rate [/h]	0	0	0	0	0	0	0	0	0	0	0	0
v_do, Outbound Pedestrian Volume crossing	2			1			1			0		
v_di, Inbound Pedestrian Volume crossing m	1			0			2			1		
v_co, Outbound Pedestrian Volume crossing	0			0			0			0		
v_ci, Inbound Pedestrian Volume crossing mi	0			0			0			0		
v_ab, Corner Pedestrian Volume [ped/h]	0			0			0			0		
Bicycle Volume [bicycles/h]	0			0			1			0		



**Intersection Settings**

Located in CBD	No
Signal Coordination Group	-
Cycle Length [s]	90
Active Pattern	Free Running (No Pattern)
Coordination Type	<i>Free Running</i>
Actuation Type	<i>Fully actuated</i>
Offset [s]	0.0
Offset Reference	Lead Green - Beginning of First Green
Permissive Mode	SingleBand
Lost time [s]	12.00

**Phasing & Timing (Basic)**

Control Type	Protecte	Permiss	Permiss	Protecte	Permiss	Permiss	Protecte	Permiss	Permiss	Protecte	Permiss	Permiss
Signal Group	3	8	0	7	4	0	5	2	0	1	6	0
Auxiliary Signal Groups												
Maximum Green [s]	30	30	0	20	20	0	20	25	0	20	25	0
Amber [s]	3.0	3.0	0.0	3.0	3.0	0.0	3.0	3.6	0.0	3.0	3.6	0.0
All red [s]	1.0	1.0	0.0	1.0	1.0	0.0	1.0	1.0	0.0	1.0	1.0	0.0
Walk [s]	0	4	0	0	4	0	0	4	0	0	4	0
Pedestrian Clearance [s]	0	24	0	0	21	0	0	16	0	0	17	0
Delayed Vehicle Green [s]	0.0	0.0	0.0	0.0	0.0	0.0	0.0	0.0	0.0	0.0	0.0	0.0
Rest In Walk		No			No			No			No	
I1, Start-Up Lost Time [s]	2.0	2.0	0.0	2.0	2.0	0.0	2.0	2.0	0.0	2.0	2.0	0.0
I2, Clearance Lost Time [s]	2.0	2.0	0.0	2.0	2.0	0.0	2.0	2.0	0.0	2.0	2.0	0.0
Detector Location [ft]	0.0	0.0	0.0	0.0	0.0	0.0	0.0	0.0	0.0	0.0	0.0	0.0
Detector Length [ft]	20.0	20.0	0.0	20.0	20.0	0.0	20.0	20.0	0.0	20.0	20.0	0.0
I, Upstream Filtering Factor	1.00	1.00	1.00	1.00	1.00	1.00	1.00	1.00	1.00	1.00	1.00	1.00

**Phasing & Timing: Free Running (No Pattern)**

Split [s]	9	14	0	9	14	0	9	14	0	9	14	0
Lead / Lag	Lead	-	-	Lead	-	-	Lead	-	-	Lead	-	-
Minimum Green [s]	5	10	0	5	10	0	5	10	0	5	10	0
Vehicle Extension [s]	2.0	4.0	0.0	2.0	4.0	0.0	2.0	4.0	0.0	2.0	4.0	0.0
Minimum Recall	No	No		No	No		No	Yes		No	Yes	
Maximum Recall	No	No		No	No		No	No		No	No	
Pedestrian Recall	No	No		No	No		No	No		No	No	

**Exclusive Pedestrian Phase**

Pedestrian Signal Group	0
Pedestrian Walk [s]	0
Pedestrian Clearance [s]	0



**Lane Group Calculations**

Lane Group	L	C	L	C	L	C	R	L	C
C, Cycle Length [s]	32	32	32	32	32	32	32	32	32
L, Total Lost Time per Cycle [s]	4.00	4.00	4.00	4.00	4.00	4.00	4.00	4.00	4.00
l1_p, Permitted Start-Up Lost Time [s]	0.00	0.00	0.00	0.00	0.00	0.00	0.00	0.00	0.00
l2, Clearance Lost Time [s]	2.00	2.00	2.00	2.00	2.00	2.00	2.00	2.00	2.00
g_i, Effective Green Time [s]	0	6	0	5	3	10	10	0	8
g / C, Green / Cycle	0.01	0.17	0.00	0.16	0.09	0.32	0.32	0.00	0.24
(v / s)_i Volume / Saturation Flow Rate	0.01	0.00	0.00	0.05	0.05	0.14	0.01	0.00	0.07
s, saturation flow rate [veh/h]	1810	1665	1810	1621	1810	1900	1574	1810	1897
c, Capacity [veh/h]	26	290	8	267	156	616	510	6	457
d1, Uniform Delay [s]	15.83	11.08	16.08	11.91	14.21	8.55	7.46	16.11	10.04
k, delay calibration	0.04	0.15	0.04	0.15	0.04	0.15	0.15	0.04	0.15
l, Upstream Filtering Factor	1.00	1.00	1.00	1.00	1.00	1.00	1.00	1.00	1.00
d2, Incremental Delay [s]	3.58	0.03	9.78	0.92	1.18	0.64	0.03	13.21	0.51
d3, Initial Queue Delay [s]	0.00	0.00	0.00	0.00	0.00	0.00	0.00	0.00	0.00
Rp, platoon ratio	1.00	1.00	1.00	1.00	1.00	1.00	1.00	1.00	1.00
PF, progression factor	1.00	1.00	1.00	1.00	1.00	1.00	1.00	1.00	1.00

**Lane Group Results**

X, volume / capacity	0.39	0.02	0.37	0.31	0.56	0.42	0.03	0.35	0.30
d, Delay for Lane Group [s/veh]	19.41	11.11	25.86	12.83	15.40	9.19	7.50	29.32	10.55
Lane Group LOS	B	B	C	B	B	A	A	C	B
Critical Lane Group	Yes	No	No	Yes	No	Yes	No	Yes	No
50th-Percentile Queue Length [veh/ln]	0.09	0.03	0.04	0.47	0.54	1.05	0.05	0.03	0.63
50th-Percentile Queue Length [ft/ln]	2.13	0.63	1.01	11.65	13.55	26.34	1.32	0.82	15.84
95th-Percentile Queue Length [veh/ln]	0.15	0.05	0.07	0.84	0.98	1.90	0.09	0.06	1.14
95th-Percentile Queue Length [ft/ln]	3.84	1.14	1.82	20.97	24.38	47.41	2.37	1.48	28.51

**Movement, Approach, & Intersection Results**

d_M, Delay for Movement [s/veh]	19.41	11.11	11.11	25.86	12.83	12.83	15.40	9.19	7.50	29.32	10.55	10.55
Movement LOS	B	B	B	C	B	B	B	A	A	C	B	B
d_A, Approach Delay [s/veh]	16.65			13.29			10.64			10.82		
Approach LOS	B			B			B			B		
d_I, Intersection Delay [s/veh]	11.21											
Intersection LOS	B											
Intersection V/C	0.307											

**Emissions**

Vehicle Miles Traveled [mph]	0.27	0.14	0.11	3.05	20.01	58.43	3.41	0.42	28.54
Stops [stops/h]	9.52	2.83	4.52	52.03	60.51	117.66	5.89	3.68	70.76
Fuel consumption [US gal/h]	0.10	0.03	0.05	0.63	1.43	3.54	0.20	0.05	1.86
CO [g/h]	7.22	2.28	3.17	43.83	100.21	247.18	13.69	3.47	129.71
NOx [g/h]	1.41	0.44	0.62	8.53	19.50	48.09	2.66	0.68	25.24
VOC [g/h]	1.67	0.53	0.73	10.16	23.22	57.29	3.17	0.80	30.06

**Other Modes**

g_Walk,mi, Effective Walk Time [s]	8.0	8.0	8.0	8.0
M_corner, Corner Circulation Area [ft <sup>2</sup> /ped]	0.00	0.00	0.00	0.00
M_CW, Crosswalk Circulation Area [ft <sup>2</sup> /ped]	0.00	0.00	0.00	0.00
d_p, Pedestrian Delay [s]	9.11	9.11	9.11	9.11
I_p,int, Pedestrian LOS Score for Intersectio	1.897	1.943	2.219	2.016
Crosswalk LOS	A	A	B	B
s_b, Saturation Flow Rate of the bicycle lane	2000	2000	2000	2000
c_b, Capacity of the bicycle lane [bicycles/h]	1861	1241	1551	1551
d_b, Bicycle Delay [s]	0.08	2.32	0.81	0.81
I_b,int, Bicycle LOS Score for Intersection	1.584	1.700	2.154	1.786
Bicycle LOS	A	A	B	A

**Sequence**

Ring 1	1	2	3	4	-	-	-	-	-	-	-	-	-	-	-
Ring 2	5	6	7	8	-	-	-	-	-	-	-	-	-	-	-
Ring 3	-	-	-	-	-	-	-	-	-	-	-	-	-	-	-
Ring 4	-	-	-	-	-	-	-	-	-	-	-	-	-	-	-



**Intersection Level Of Service Report**

**Intersection 15: Central Parkway & Panorama Drive/Pino Grande Road**

Control Type:	All-way stop	Delay (sec / veh):	8.3
Analysis Method:	HCM 7th Edition	Level Of Service:	A
Analysis Period:	15 minutes	Volume to Capacity (v/c):	0.180

**Intersection Setup**

Name	Pino Grande Road			Panorama Drive			Central Parkway			Central Parkway		
Approach	Northbound			Southbound			Eastbound			Westbound		
Lane Configuration	+			+			+			+		
Turning Movement	Left	Thru	Right	Left	Thru	Right	Left	Thru	Right	Left	Thru	Right
Lane Width [ft]	12.00	12.00	12.00	12.00	12.00	12.00	12.00	12.00	12.00	12.00	12.00	12.00
No. of Lanes in Entry Pocket	0	0	0	0	0	1	1	0	0	1	0	0
Entry Pocket Length [ft]	100.00	100.00	100.00	100.00	100.00	100.00	275.00	100.00	100.00	100.00	100.00	100.00
No. of Lanes in Exit Pocket	0	0	0	0	0	0	0	0	0	0	0	0
Exit Pocket Length [ft]	0.00	0.00	0.00	0.00	0.00	0.00	0.00	0.00	0.00	0.00	0.00	0.00
Speed [mph]	30.00			30.00			30.00			30.00		
Grade [%]	0.00			0.00			0.00			0.00		
Crosswalk	Yes			Yes			Yes			Yes		

**Volumes**

Name	Pino Grande Road			Panorama Drive			Central Parkway			Central Parkway		
Base Volume Input [veh/h]	19	1	0	1	1	70	95	82	54	0	45	6
Base Volume Adjustment Factor	1.0000	1.0000	1.0000	1.0000	1.0000	1.0000	1.0000	1.0000	1.0000	1.0000	1.0000	1.0000
Heavy Vehicles Percentage [%]	0.00	0.00	0.00	0.00	0.00	0.00	0.00	0.00	0.00	0.00	0.00	0.00
Growth Factor	1.0000	1.0000	1.0000	1.0000	1.0000	1.0000	1.0000	1.0000	1.0000	1.0000	1.0000	1.0000
In-Process Volume [veh/h]	0	0	0	0	0	0	0	0	0	0	0	0
Site-Generated Trips [veh/h]	0	0	0	0	0	0	0	0	0	0	0	0
Diverted Trips [veh/h]	0	0	0	0	0	0	0	0	0	0	0	0
Pass-by Trips [veh/h]	0	0	0	0	0	0	0	0	0	0	0	0
Existing Site Adjustment Volume [veh/h]	0	0	0	0	0	0	0	0	0	0	0	0
Other Volume [veh/h]	0	0	0	0	0	0	0	0	0	0	0	0
Total Hourly Volume [veh/h]	19	1	0	1	1	70	95	82	54	0	45	6
Peak Hour Factor	0.9400	0.9400	0.9400	0.9400	0.9400	0.9400	0.9400	0.9400	0.9400	0.9400	0.9400	0.9400
Other Adjustment Factor	1.0000	1.0000	1.0000	1.0000	1.0000	1.0000	1.0000	1.0000	1.0000	1.0000	1.0000	1.0000
Total 15-Minute Volume [veh/h]	5	0	0	0	0	19	25	22	14	0	12	2
Total Analysis Volume [veh/h]	20	1	0	1	1	74	101	87	57	0	48	6
Pedestrian Volume [ped/h]	2			3			2			4		



**Intersection Settings**

**Lanes**

Capacity per Entry Lane [veh/h]	656	656	794	681	798	727	739
Degree of Utilization, x	0.03	0.00	0.09	0.15	0.18	0.00	0.07

**Movement, Approach, & Intersection Results**

95th-Percentile Queue Length [veh]	0.10	0.01	0.31	0.52	0.65	0.00	0.24
95th-Percentile Queue Length [ft]	2.48	0.23	7.68	12.97	16.37	0.00	5.90
Approach Delay [s/veh]	8.67	7.71		8.49		7.96	
Approach LOS	A	A		A		A	
Intersection Delay [s/veh]	8.28						
Intersection LOS	A						



**Intersection Level Of Service Report**  
**Intersection 16: Airway Boulevard & N. Canyons Parkway**

Control Type:	Signalized	Delay (sec / veh):	25.1
Analysis Method:	HCM 7th Edition	Level Of Service:	C
Analysis Period:	15 minutes	Volume to Capacity (v/c):	0.618

**Intersection Setup**

Name	Airway Boulevard			Driveway			N. Canyons Parkway			N Canyons Parkway		
Approach	Northbound			Southbound			Eastbound			Westbound		
Lane Configuration	↑↑↑			+			↑			↑↑↑		
Turning Movement	Left	Thru	Right	Left	Thru	Right	Left	Thru	Right	Left	Thru	Right
Lane Width [ft]	12.00	12.00	12.00	12.00	12.00	12.00	12.00	12.00	12.00	12.00	12.00	12.00
No. of Lanes in Entry Pocket	0	0	0	0	0	0	0	0	0	1	0	1
Entry Pocket Length [ft]	100.00	100.00	100.00	100.00	100.00	100.00	100.00	100.00	100.00	110.00	100.00	195.00
No. of Lanes in Exit Pocket	0	0	0	0	0	0	0	0	0	0	0	0
Exit Pocket Length [ft]	0.00	0.00	0.00	0.00	0.00	0.00	0.00	0.00	0.00	0.00	0.00	0.00
Speed [mph]	40.00			30.00			40.00			40.00		
Grade [%]	0.00			0.00			0.00			0.00		
Curb Present	Yes			Yes			Yes			Yes		
Crosswalk	Yes			Yes			Yes			No		





**Volumes**

Name	Airway Boulevard			Driveway			N. Canyons Parkway			N Canyons Parkway		
Base Volume Input [veh/h]	121	39	602	2	8	2	0	387	273	761	33	9
Base Volume Adjustment Factor	1.0000	1.0000	1.0000	1.0000	1.0000	1.0000	1.0000	1.0000	1.0000	1.0000	1.0000	1.0000
Heavy Vehicles Percentage [%]	4.50	2.60	1.20	0.00	0.00	0.00	2.00	0.00	1.70	0.70	0.00	0.00
Proportion of CAVs [%]	0.00											
Growth Factor	1.0000	1.0000	1.0000	1.0000	1.0000	1.0000	1.0000	1.0000	1.0000	1.0000	1.0000	1.0000
In-Process Volume [veh/h]	0	0	0	0	0	0	0	0	0	0	0	0
Site-Generated Trips [veh/h]	0	0	0	0	0	0	0	0	0	0	0	0
Diverted Trips [veh/h]	0	0	0	0	0	0	0	0	0	0	0	0
Pass-by Trips [veh/h]	0	0	0	0	0	0	0	0	0	0	0	0
Existing Site Adjustment Volume [veh/h]	0	0	0	0	0	0	0	0	0	0	0	0
Other Volume [veh/h]	0	0	0	0	0	0	0	0	0	0	0	0
Right Turn on Red Volume [veh/h]	0	0	0	0	0	0	0	0	0	0	0	0
Total Hourly Volume [veh/h]	121	39	602	2	8	2	0	387	273	761	33	9
Peak Hour Factor	0.9300	0.9300	0.9300	0.9300	0.9300	0.9300	1.0000	0.9300	0.9300	0.9300	0.9300	0.9300
Other Adjustment Factor	1.0000	1.0000	1.0000	1.0000	1.0000	1.0000	1.0000	1.0000	1.0000	1.0000	1.0000	1.0000
Total 15-Minute Volume [veh/h]	33	10	162	1	2	1	0	104	73	205	9	2
Total Analysis Volume [veh/h]	130	42	647	2	9	2	0	416	294	818	35	10
Presence of On-Street Parking	No		No	No		No	No		No	No		No
On-Street Parking Maneuver Rate [/h]	0	0	0	0	0	0	0	0	0	0	0	0
Local Bus Stopping Rate [/h]	0	0	0	0	0	0	0	0	0	0	0	0
v_do, Outbound Pedestrian Volume crossing	2			0			1			0		
v_di, Inbound Pedestrian Volume crossing m	1			0			2			0		
v_co, Outbound Pedestrian Volume crossing	0			0			0			0		
v_ci, Inbound Pedestrian Volume crossing mi	0			0			0			0		
v_ab, Corner Pedestrian Volume [ped/h]	0			0			0			0		
Bicycle Volume [bicycles/h]	0			0			0			0		



**Intersection Settings**

Located in CBD	No
Signal Coordination Group	-
Cycle Length [s]	105
Active Pattern	Pattern 1
Coordination Type	Time of Day Pattern Coordinated
Actuation Type	Fully actuated
Offset [s]	100.0
Offset Reference	Lead Green - Beginning of First Green
Permissive Mode	SingleBand
Lost time [s]	12.00

**Phasing & Timing (Basic)**

Control Type	Split	Split	Overlap	Split	Split	Split	Permiss	Permiss	Permiss	Protecte	Permiss	Permiss
Signal Group	0	8	8	0	4	0	0	2	0	1	6	0
Auxiliary Signal Groups			1,8									
Maximum Green [s]	0	20	20	0	12	0	0	15	0	50	50	0
Amber [s]	0.0	3.2	3.2	0.0	3.0	0.0	0.0	5.0	0.0	5.0	5.0	0.0
All red [s]	0.0	1.0	1.0	0.0	1.0	0.0	0.0	1.0	0.0	1.0	1.0	0.0
Walk [s]	0	0	0	0	5	0	0	5	0	0	5	0
Pedestrian Clearance [s]	0	0	0	0	28	0	0	29	0	0	12	0
Delayed Vehicle Green [s]	0.0	0.0	0.0	0.0	0.0	0.0	0.0	0.0	0.0	0.0	0.0	0.0
Rest In Walk		No			No			No			No	
I1, Start-Up Lost Time [s]	0.0	2.0	2.0	0.0	2.0	0.0	0.0	2.0	0.0	2.0	2.0	0.0
I2, Clearance Lost Time [s]	0.0	2.0	2.0	0.0	2.0	0.0	0.0	2.0	0.0	2.0	2.0	0.0
Detector Location [ft]	0.0	0.0	0.0	0.0	0.0	0.0	0.0	0.0	0.0	0.0	0.0	0.0
Detector Length [ft]	0.0	20.0	20.0	0.0	20.0	0.0	0.0	20.0	0.0	20.0	20.0	0.0
I, Upstream Filtering Factor	1.00	1.00	1.00	1.00	1.00	1.00	1.00	1.00	1.00	1.00	1.00	1.00

**Phasing & Timing: Pattern 1**

Split [s]	0	22	22	0	20	0	0	33	0	30	63	0
Lead / Lag	-	-	-	-	-	-	-	-	-	Lead	-	-
Minimum Green [s]	0	4	4	0	3	0	0	10	0	3	7	0
Vehicle Extension [s]	0.0	2.0	2.0	0.0	2.0	0.0	0.0	2.0	0.0	2.0	2.0	0.0
Minimum Recall		No	No		No			No		No	Yes	
Maximum Recall		No	No		No			No		Yes	Yes	
Pedestrian Recall		No	No		No			No		No	No	

**Exclusive Pedestrian Phase**

Pedestrian Signal Group	0
Pedestrian Walk [s]	0
Pedestrian Clearance [s]	0



**Lane Group Calculations**

Lane Group	C	R	C	C	R	L	C	R
C, Cycle Length [s]	105	105	105	105	105	105	105	105
L, Total Lost Time per Cycle [s]	4.00	4.00	4.00	4.00	4.00	4.00	4.00	4.00
l1_p, Permitted Start-Up Lost Time [s]	0.00	0.00	0.00	0.00	0.00	0.00	0.00	0.00
l2, Clearance Lost Time [s]	2.00	0.00	2.00	2.00	2.00	2.00	2.00	2.00
g_i, Effective Green Time [s]	15	68	1	24	24	49	77	77
g / C, Green / Cycle	0.14	0.65	0.01	0.23	0.23	0.47	0.73	0.73
(v / s)_i Volume / Saturation Flow Rate	0.10	0.23	0.01	0.11	0.19	0.23	0.02	0.01
s, saturation flow rate [veh/h]	1793	2831	1836	3618	1587	3495	1900	1615
c, Capacity [veh/h]	258	1789	17	816	358	1638	1392	1183
d1, Uniform Delay [s]	42.56	9.23	51.91	35.58	38.61	19.35	3.83	3.78
k, delay calibration	0.04	0.50	0.04	0.04	0.20	0.50	0.50	0.50
l, Upstream Filtering Factor	1.00	1.00	1.00	1.00	1.00	1.00	1.00	1.00
d2, Incremental Delay [s]	1.11	0.57	22.97	0.18	8.25	1.09	0.03	0.01
d3, Initial Queue Delay [s]	0.00	0.00	0.00	0.00	0.00	0.00	0.00	0.00
Rp, platoon ratio	1.00	1.00	1.00	1.00	1.00	1.00	1.00	1.00
PF, progression factor	1.00	1.00	1.00	1.00	1.00	1.00	1.00	1.00

**Lane Group Results**

X, volume / capacity	0.67	0.36	0.77	0.51	0.82	0.50	0.03	0.01
d, Delay for Lane Group [s/veh]	43.67	9.80	74.88	35.76	46.86	20.44	3.86	3.79
Lane Group LOS	D	A	E	D	D	C	A	A
Critical Lane Group	No	Yes	Yes	No	Yes	Yes	No	No
50th-Percentile Queue Length [veh/ln]	4.20	3.24	0.45	4.55	7.76	6.73	0.17	0.05
50th-Percentile Queue Length [ft/ln]	104.92	81.09	11.22	113.63	194.03	168.32	4.29	1.23
95th-Percentile Queue Length [veh/ln]	7.55	5.84	0.81	8.04	12.33	10.99	0.31	0.09
95th-Percentile Queue Length [ft/ln]	188.86	145.96	20.20	201.05	308.25	274.70	7.72	2.21



**Movement, Approach, & Intersection Results**

d_M, Delay for Movement [s/veh]	43.67	43.67	9.80	74.88	74.88	74.88	0.00	35.76	46.86	20.44	3.86	3.79
Movement LOS	D	D	A	E	E	E		D	D	C	A	A
d_A, Approach Delay [s/veh]	16.91			74.88				40.36		19.58		
Approach LOS	B			E				D		B		
d_I, Intersection Delay [s/veh]	25.10											
Intersection LOS	C											
Intersection V/C	0.618											

**Emissions**

Vehicle Miles Traveled [mph]	20.42	76.83	0.45	27.12	19.16	66.90	2.86	0.82
Stops [stops/h]	143.88	222.40	15.39	311.65	266.07	461.62	5.88	1.68
Fuel consumption [US gal/h]	3.67	6.23	0.30	7.06	6.10	10.33	0.19	0.05
CO [g/h]	256.76	435.25	21.08	493.49	426.63	722.33	13.13	3.74
NOx [g/h]	49.96	84.68	4.10	96.01	83.01	140.54	2.55	0.73
VOC [g/h]	59.51	100.87	4.88	114.37	98.88	167.41	3.04	0.87

**Other Modes**

g_Walk,mi, Effective Walk Time [s]	9.0	9.0	9.0	0.0
M_corner, Corner Circulation Area [ft <sup>2</sup> /ped]	0.00	0.00	0.00	0.00
M_CW, Crosswalk Circulation Area [ft <sup>2</sup> /ped]	1355.33	0.00	0.00	0.00
d_p, Pedestrian Delay [s]	43.89	43.89	43.89	0.00
I_p,int, Pedestrian LOS Score for Intersectio	2.882	1.756	2.537	0.000
Crosswalk LOS	C	A	B	F
s_b, Saturation Flow Rate of the bicycle lane	2000	2000	2000	2000
c_b, Capacity of the bicycle lane [bicycles/h]	339	305	514	1086
d_b, Bicycle Delay [s]	36.21	37.72	28.98	10.98
I_b,int, Bicycle LOS Score for Intersection	2.911	1.581	2.145	2.984
Bicycle LOS	C	A	B	C

**Sequence**

Ring 1	1	2	4	8	-	-	-	-	-	-	-	-	-	-	-
Ring 2	-	6	-	-	-	-	-	-	-	-	-	-	-	-	-
Ring 3	-	-	-	-	-	-	-	-	-	-	-	-	-	-	-
Ring 4	-	-	-	-	-	-	-	-	-	-	-	-	-	-	-

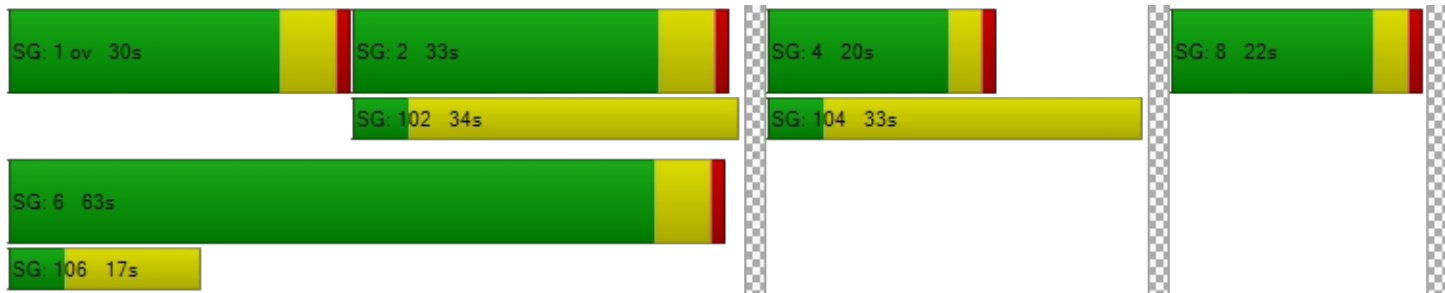

**Intersection Level Of Service Report**  
**Intersection 17: Airway Boulevard & I-580 WB Ramps**

Control Type:	Signalized	Delay (sec / veh):	9.0
Analysis Method:	HCM 7th Edition	Level Of Service:	A
Analysis Period:	15 minutes	Volume to Capacity (v/c):	0.251

**Intersection Setup**

Name	Airway Boulevard			Airway Boulevard			I-580 WB On-Ramp			I-580 WB Off-Ramp		
Approach	Northbound			Southbound			Eastbound			Westbound		
Lane Configuration	r			r						r r r		
Turning Movement	Left	Thru	Right	Left	Thru	Right	Left	Thru	Right	Left	Thru	Right
Lane Width [ft]	12.00	12.00	12.00	12.00	12.00	12.00	12.00	12.00	12.00	12.00	12.00	12.00
No. of Lanes in Entry Pocket	0	0	0	0	0	1	0	0	0	1	0	1
Entry Pocket Length [ft]	100.00	100.00	100.00	100.00	100.00	250.00	100.00	100.00	100.00	150.00	100.00	490.00
No. of Lanes in Exit Pocket	0	0	0	0	0	0	0	0	0	0	0	0
Exit Pocket Length [ft]	0.00	0.00	0.00	0.00	0.00	0.00	0.00	0.00	0.00	0.00	0.00	0.00
Speed [mph]	40.00			40.00			30.00			45.00		
Grade [%]	0.00			0.00			0.00			0.00		
Curb Present	Yes			Yes						Yes		
Crosswalk	No			No			No			Yes		



**Volumes**

Name	Airway Boulevard			Airway Boulevard			I-580 WB On-Ramp			I-580 WB Off-Ramp		
Base Volume Input [veh/h]	0	709	211	0	401	740	0	0	0	50	0	187
Base Volume Adjustment Factor	1.0000	1.0000	1.0000	1.0000	1.0000	1.0000	1.0000	1.0000	1.0000	1.0000	1.0000	1.0000
Heavy Vehicles Percentage [%]	2.00	1.20	0.00	2.00	0.40	0.70	2.00	2.00	2.00	0.00	0.00	1.10
Proportion of CAVs [%]	0.00											
Growth Factor	1.0000	1.0000	1.0000	1.0000	1.0000	1.0000	1.0000	1.0000	1.0000	1.0000	1.0000	1.0000
In-Process Volume [veh/h]	0	0	0	0	0	0	0	0	0	0	0	0
Site-Generated Trips [veh/h]	0	0	0	0	0	0	0	0	0	0	0	0
Diverted Trips [veh/h]	0	0	0	0	0	0	0	0	0	0	0	0
Pass-by Trips [veh/h]	0	0	0	0	0	0	0	0	0	0	0	0
Existing Site Adjustment Volume [veh/h]	0	0	0	0	0	0	0	0	0	0	0	0
Other Volume [veh/h]	0	0	0	0	0	0	0	0	0	0	0	0
Right Turn on Red Volume [veh/h]	0	0	0	0	0	0	0	0	0	0	0	0
Total Hourly Volume [veh/h]	0	709	211	0	401	740	0	0	0	50	0	187
Peak Hour Factor	1.0000	0.8900	0.8900	1.0000	0.8900	0.8900	1.0000	1.0000	1.0000	0.8900	0.8900	0.8900
Other Adjustment Factor	1.0000	1.0000	1.0000	1.0000	1.0000	1.0000	1.0000	1.0000	1.0000	1.0000	1.0000	1.0000
Total 15-Minute Volume [veh/h]	0	199	59	0	113	208	0	0	0	14	0	53
Total Analysis Volume [veh/h]	0	797	237	0	451	831	0	0	0	56	0	210
Presence of On-Street Parking	No		No	No		No				No		No
On-Street Parking Maneuver Rate [/h]	0	0	0	0	0	0	0	0	0	0	0	0
Local Bus Stopping Rate [/h]	0	0	0	0	0	0	0	0	0	0	0	0
v_do, Outbound Pedestrian Volume crossing	0			0			0			0		
v_di, Inbound Pedestrian Volume crossing m	0			0			0			0		
v_co, Outbound Pedestrian Volume crossing	0			0			0			0		
v_ci, Inbound Pedestrian Volume crossing mi	0			0			0			0		
v_ab, Corner Pedestrian Volume [ped/h]	0			0			0			0		
Bicycle Volume [bicycles/h]	1			0			0			0		



**Intersection Settings**

Located in CBD	No
Signal Coordination Group	-
Cycle Length [s]	105
Active Pattern	Pattern 1
Coordination Type	Time of Day Pattern Coordinated
Actuation Type	Fully actuated
Offset [s]	35.0
Offset Reference	Lead Green - Beginning of First Green
Permissive Mode	SingleBand
Lost time [s]	9.00

**Phasing & Timing (Basic)**

Control Type	Permiss	Permiss	Unsigna	Permiss	Permiss	Unsigna	Permiss	Permiss	Permiss	Permiss	Permiss	Overlap
Signal Group	0	2	0	0	6	0	0	0	0	0	8	1
Auxiliary Signal Groups												1,8
Maximum Green [s]	0	30	0	0	25	0	0	0	0	0	20	12
Amber [s]	0.0	4.3	0.0	0.0	4.3	0.0	0.0	0.0	0.0	0.0	3.0	3.0
All red [s]	0.0	1.0	0.0	0.0	1.0	0.0	0.0	0.0	0.0	0.0	1.0	0.0
Walk [s]	0	7	0	0	0	0	0	0	0	0	0	0
Pedestrian Clearance [s]	0	15	0	0	0	0	0	0	0	0	0	0
Delayed Vehicle Green [s]	0.0	0.0	0.0	0.0	0.0	0.0	0.0	0.0	0.0	0.0	0.0	0.0
Rest In Walk		No			No						No	
I1, Start-Up Lost Time [s]	0.0	2.0	0.0	0.0	2.0	0.0	0.0	0.0	0.0	0.0	2.0	2.0
I2, Clearance Lost Time [s]	0.0	2.0	0.0	0.0	2.0	0.0	0.0	0.0	0.0	0.0	2.0	2.0
Detector Location [ft]	0.0	0.0	0.0	0.0	0.0	0.0	0.0	0.0	0.0	0.0	0.0	0.0
Detector Length [ft]	0.0	20.0	0.0	0.0	20.0	0.0	0.0	0.0	0.0	0.0	20.0	20.0
I, Upstream Filtering Factor	1.00	1.00	1.00	1.00	1.00	1.00	1.00	1.00	1.00	1.00	1.00	1.00

**Phasing & Timing: Pattern 1**

Split [s]	0	68	0	0	83	0	0	0	0	0	22	15
Lead / Lag	-	-	-	-	-	-	-	-	-	-	-	-
Minimum Green [s]	0	11	0	0	8	0	0	0	0	0	4	4
Vehicle Extension [s]	0.0	0.0	0.0	0.0	0.0	0.0	0.0	0.0	0.0	0.0	0.0	0.0
Minimum Recall		Yes			Yes						No	No
Maximum Recall		No			No						No	No
Pedestrian Recall		No			No						No	No

**Exclusive Pedestrian Phase**

Pedestrian Signal Group	0
Pedestrian Walk [s]	0
Pedestrian Clearance [s]	0



**Lane Group Calculations**

Lane Group	C	C		L	C	R
C, Cycle Length [s]	105	105		105	105	105
L, Total Lost Time per Cycle [s]	4.00	4.00		4.00	4.00	4.00
l1_p, Permitted Start-Up Lost Time [s]	0.00	0.00		0.00	0.00	0.00
l2, Clearance Lost Time [s]	2.00	2.00		2.00	2.00	0.00
g_i, Effective Green Time [s]	77	88		9	9	20
g / C, Green / Cycle	0.73	0.84		0.08	0.08	0.19
(v / s)_i Volume / Saturation Flow Rate	0.22	0.09		0.02	0.02	0.07
s, saturation flow rate [veh/h]	3583	5159		1810	1810	2834
c, Capacity [veh/h]	2617	4339		150	150	575
d1, Uniform Delay [s]	4.91	1.45		44.82	44.82	35.97
k, delay calibration	0.50	0.50		0.04	0.04	0.04
l, Upstream Filtering Factor	1.00	1.00		1.00	1.00	1.00
d2, Incremental Delay [s]	0.30	0.05		0.22	0.22	0.14
d3, Initial Queue Delay [s]	0.00	0.00		0.00	0.00	0.00
Rp, platoon ratio	1.00	1.00		1.00	1.00	1.00
PF, progression factor	1.00	1.00		1.00	1.00	1.00

**Lane Group Results**

X, volume / capacity	0.30	0.10		0.19	0.19	0.36
d, Delay for Lane Group [s/veh]	5.21	1.50		45.04	45.04	36.11
Lane Group LOS	A	A		D	D	D
Critical Lane Group	Yes	No		No	No	Yes
50th-Percentile Queue Length [veh/ln]	2.43	0.23		0.67	0.67	2.24
50th-Percentile Queue Length [ft/ln]	60.79	5.82		16.71	16.71	56.03
95th-Percentile Queue Length [veh/ln]	4.38	0.42		1.20	1.20	4.03
95th-Percentile Queue Length [ft/ln]	109.42	10.47		30.07	30.07	100.85



**Movement, Approach, & Intersection Results**

d_M, Delay for Movement [s/veh]	0.00	5.21	0.00	0.00	1.50	0.00	0.00	0.00	0.00	0.00	45.04	45.04	36.11
Movement LOS		A			A						D	D	D
d_A, Approach Delay [s/veh]	4.12				0.57				0.00		37.99		
Approach LOS	A				A				A		D		
d_I, Intersection Delay [s/veh]	9.01												
Intersection LOS	A												
Intersection V/C	0.251												

**Emissions**

Vehicle Miles Traveled [mph]	66.48	53.55		2.75	2.75	20.65
Stops [stops/h]	166.83	23.96		22.93	22.93	153.76
Fuel consumption [US gal/h]	4.87	2.29		0.64	0.64	4.16
CO [g/h]	340.10	160.16		44.46	44.46	291.00
NOx [g/h]	66.17	31.16		8.65	8.65	56.62
VOC [g/h]	78.82	37.12		10.30	10.30	67.44

**Other Modes**

g_Walk,mi, Effective Walk Time [s]	0.0	0.0	0.0	11.0
M_corner, Corner Circulation Area [ft <sup>2</sup> /ped]	0.00	0.00	0.00	0.00
M_CW, Crosswalk Circulation Area [ft <sup>2</sup> /ped]	0.00	0.00	0.00	0.00
d_p, Pedestrian Delay [s]	0.00	0.00	0.00	42.05
I_p,int, Pedestrian LOS Score for Intersectio	0.000	0.000	0.000	2.385
Crosswalk LOS	F	F	F	B
s_b, Saturation Flow Rate of the bicycle lane	2000	2000	2000	2000
c_b, Capacity of the bicycle lane [bicycles/h]	1195	1481	0	343
d_b, Bicycle Delay [s]	8.51	3.54	52.47	36.01
I_b,int, Bicycle LOS Score for Intersection	2.217	1.808	4.132	1.999
Bicycle LOS	B	A	D	A

**Sequence**

Ring 1	1	2	-	-	-	-	-	-	-	-	-	-	-	-	-	-
Ring 2	-	6	-	8	-	-	-	-	-	-	-	-	-	-	-	-
Ring 3	-	-	-	-	-	-	-	-	-	-	-	-	-	-	-	-
Ring 4	-	-	-	-	-	-	-	-	-	-	-	-	-	-	-	-



**Intersection Level Of Service Report**

**Intersection 19: Pandora Way & Residential Project Access Driveway (Parcel 7)**

Control Type:	All-way stop	Delay (sec / veh):	7.1
Analysis Method:	HCM 7th Edition	Level Of Service:	A
Analysis Period:	15 minutes	Volume to Capacity (v/c):	0.055

**Intersection Setup**

Name	Residential Project Access (Parcel 7)		Pino Grande Road		Pandora Way	
Approach	Northbound		Southbound		Westbound	
Lane Configuration	↩		↩		↩	
Turning Movement	Thru	Right	Left	Thru	Left	Right
Lane Width [ft]	12.00	12.00	12.00	12.00	12.00	12.00
No. of Lanes in Entry Pocket	0	0	0	0	0	0
Entry Pocket Length [ft]	100.00	100.00	100.00	100.00	100.00	100.00
No. of Lanes in Exit Pocket	0	0	0	0	0	0
Exit Pocket Length [ft]	0.00	0.00	0.00	0.00	0.00	0.00
Speed [mph]	30.00		30.00		30.00	
Grade [%]	0.00		0.00		0.00	
Crosswalk	Yes		Yes		Yes	

**Volumes**

Name	Residential Project Access (Parcel 7)		Pino Grande Road		Pandora Way	
Base Volume Input [veh/h]	10	0	5	45	0	5
Base Volume Adjustment Factor	1.0000	1.0000	1.0000	1.0000	1.0000	1.0000
Heavy Vehicles Percentage [%]	2.00	2.00	2.00	2.00	2.00	2.00
Growth Factor	1.0000	1.0000	1.0000	1.0000	1.0000	1.0000
In-Process Volume [veh/h]	0	0	0	0	0	0
Site-Generated Trips [veh/h]	0	0	0	0	0	0
Diverted Trips [veh/h]	0	0	0	0	0	0
Pass-by Trips [veh/h]	0	0	0	0	0	0
Existing Site Adjustment Volume [veh/h]	0	0	0	0	0	0
Other Volume [veh/h]	0	0	0	0	0	0
Total Hourly Volume [veh/h]	10	0	5	45	0	5
Peak Hour Factor	1.0000	1.0000	1.0000	1.0000	1.0000	1.0000
Other Adjustment Factor	1.0000	1.0000	1.0000	1.0000	1.0000	1.0000
Total 15-Minute Volume [veh/h]	3	0	1	11	0	1
Total Analysis Volume [veh/h]	10	0	5	45	0	5
Pedestrian Volume [ped/h]	0		0		0	



**Intersection Settings****Lanes**

Capacity per Entry Lane [veh/h]	903	906	1041
Degree of Utilization, x	0.01	0.06	0.00

**Movement, Approach, & Intersection Results**

95th-Percentile Queue Length [veh]	0.03	0.17	0.01
95th-Percentile Queue Length [ft]	0.84	4.37	0.36
Approach Delay [s/veh]	7.03	7.20	6.48
Approach LOS	A	A	A
Intersection Delay [s/veh]	7.12		
Intersection LOS	A		

**Intersection Level Of Service Report**  
**Intersection 20: Croak Road & Central Parkway**

Control Type:	All-way stop	Delay (sec / veh):	7.1
Analysis Method:	HCM 7th Edition	Level Of Service:	A
Analysis Period:	15 minutes	Volume to Capacity (v/c):	0.044

**Intersection Setup**

Name	Croak Road		Croak Road		Central Parkway	
Approach	Northbound		Southbound		Eastbound	
Lane Configuration	↵		↵		↵↶	
Turning Movement	Left	Thru	Thru	Right	Left	Right
Lane Width [ft]	12.00	12.00	12.00	12.00	12.00	12.00
No. of Lanes in Entry Pocket	1	0	1	0	1	0
Entry Pocket Length [ft]	215.00	100.00	175.00	100.00	185.00	100.00
No. of Lanes in Exit Pocket	0	0	0	0	0	0
Exit Pocket Length [ft]	0.00	0.00	0.00	0.00	0.00	0.00
Speed [mph]	30.00		30.00		25.00	
Grade [%]	0.00		0.00		0.00	
Crosswalk	Yes		Yes		Yes	

**Volumes**

Name	Croak Road		Croak Road		Central Parkway	
Base Volume Input [veh/h]	15	0	0	0	0	41
Base Volume Adjustment Factor	1.0000	1.0000	1.0000	1.0000	1.0000	1.0000
Heavy Vehicles Percentage [%]	2.00	2.00	2.00	2.00	2.00	2.00
Growth Factor	1.0000	1.0000	1.0000	1.0000	1.0000	1.0000
In-Process Volume [veh/h]	0	0	0	0	0	0
Site-Generated Trips [veh/h]	0	0	0	0	0	0
Diverted Trips [veh/h]	0	0	0	0	0	0
Pass-by Trips [veh/h]	0	0	0	0	0	0
Existing Site Adjustment Volume [veh/h]	0	0	0	0	0	0
Other Volume [veh/h]	0	0	0	0	0	0
Total Hourly Volume [veh/h]	15	0	0	0	0	41
Peak Hour Factor	1.0000	1.0000	1.0000	1.0000	1.0000	1.0000
Other Adjustment Factor	1.0000	1.0000	1.0000	1.0000	1.0000	1.0000
Total 15-Minute Volume [veh/h]	4	0	0	0	0	10
Total Analysis Volume [veh/h]	15	0	0	0	0	41
Pedestrian Volume [ped/h]	0		0		0	



**Intersection Settings**

**Lanes**

Capacity per Entry Lane [veh/h]	703	779	777	787	929
Degree of Utilization, x	0.02	0.00	0.00	0.00	0.04

**Movement, Approach, & Intersection Results**

95th-Percentile Queue Length [veh]	0.07	0.00	0.00	0.00	0.14
95th-Percentile Queue Length [ft]	1.63	0.00	0.00	0.00	3.46
Approach Delay [s/veh]	7.93		0.00	6.75	
Approach LOS	A		A	A	
Intersection Delay [s/veh]	7.07				
Intersection LOS	A				



**Intersection Level Of Service Report**  
**Intersection 21: Croak Road & Project Access (Parcel 8)**

Control Type:	Two-way stop	Delay (sec / veh):	8.4
Analysis Method:	HCM 7th Edition	Level Of Service:	A
Analysis Period:	15 minutes	Volume to Capacity (v/c):	0.014

**Intersection Setup**

Name	Croak Road		Croak Road		Project Access (Parcel 8)	
Approach	Northbound		Southbound		Westbound	
Lane Configuration						
Turning Movement	Thru	Right	Left	Thru	Left	Right
Lane Width [ft]	12.00	12.00	12.00	12.00	12.00	12.00
No. of Lanes in Entry Pocket	0	0	0	0	0	0
Entry Pocket Length [ft]	100.00	100.00	100.00	100.00	100.00	100.00
No. of Lanes in Exit Pocket	0	0	0	0	0	0
Exit Pocket Length [ft]	0.00	0.00	0.00	0.00	0.00	0.00
Speed [mph]	30.00		30.00		30.00	
Grade [%]	0.00		0.00		0.00	
Crosswalk	Yes		Yes		Yes	

**Volumes**

Name	Croak Road		Croak Road		Project Access (Parcel 8)	
Base Volume Input [veh/h]	0	0	41	0	0	15
Base Volume Adjustment Factor	1.0000	1.0000	1.0000	1.0000	1.0000	1.0000
Heavy Vehicles Percentage [%]	2.00	2.00	2.00	2.00	2.00	2.00
Growth Factor	1.0000	1.0000	1.0000	1.0000	1.0000	1.0000
In-Process Volume [veh/h]	0	0	0	0	0	0
Site-Generated Trips [veh/h]	0	0	0	0	0	0
Diverted Trips [veh/h]	0	0	0	0	0	0
Pass-by Trips [veh/h]	0	0	0	0	0	0
Existing Site Adjustment Volume [veh/h]	0	0	0	0	0	0
Other Volume [veh/h]	0	0	0	0	0	0
Total Hourly Volume [veh/h]	0	0	41	0	0	15
Peak Hour Factor	1.0000	1.0000	1.0000	1.0000	1.0000	1.0000
Other Adjustment Factor	1.0000	1.0000	1.0000	1.0000	1.0000	1.0000
Total 15-Minute Volume [veh/h]	0	0	10	0	0	4
Total Analysis Volume [veh/h]	0	0	41	0	0	15
Pedestrian Volume [ped/h]	0		0		0	



**Intersection Settings**

Priority Scheme	Free	Free	Stop
Flared Lane			No
Storage Area [veh]	0	0	0
Two-Stage Gap Acceptance			No
Number of Storage Spaces in Median	0	0	0

**Movement, Approach, & Intersection Results**

V/C, Movement V/C Ratio	0.00	0.00	0.03	0.00	0.00	0.01
d_M, Delay for Movement [s/veh]	0.00	0.00	7.28	0.00	9.06	8.36
Movement LOS	A	A	A	A	A	A
95th-Percentile Queue Length [veh/ln]	0.00	0.00	0.08	0.08	0.04	0.04
95th-Percentile Queue Length [ft/ln]	0.00	0.00	1.94	1.94	1.05	1.05
d_A, Approach Delay [s/veh]	0.00		7.28		8.36	
Approach LOS	A		A		A	
d_I, Intersection Delay [s/veh]	7.57					
Intersection LOS	A					





## Appendix H: Cumulative Volume & Geometry



Lane Configuration and Traffic Control

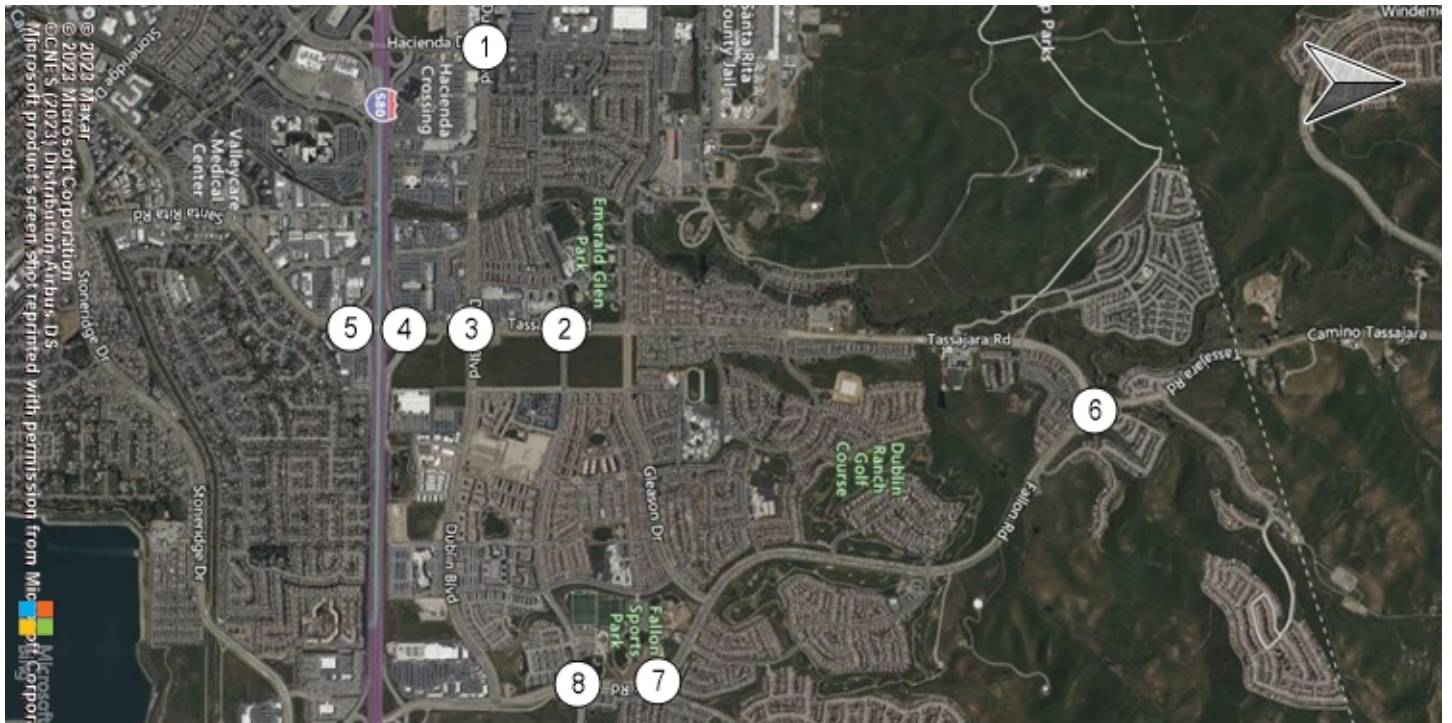

Hacienda Drive & Dublin Boul Tassajara Road & Central Pa Tassajara Road & Dublin Bou Tassajara Road & I-580 WB

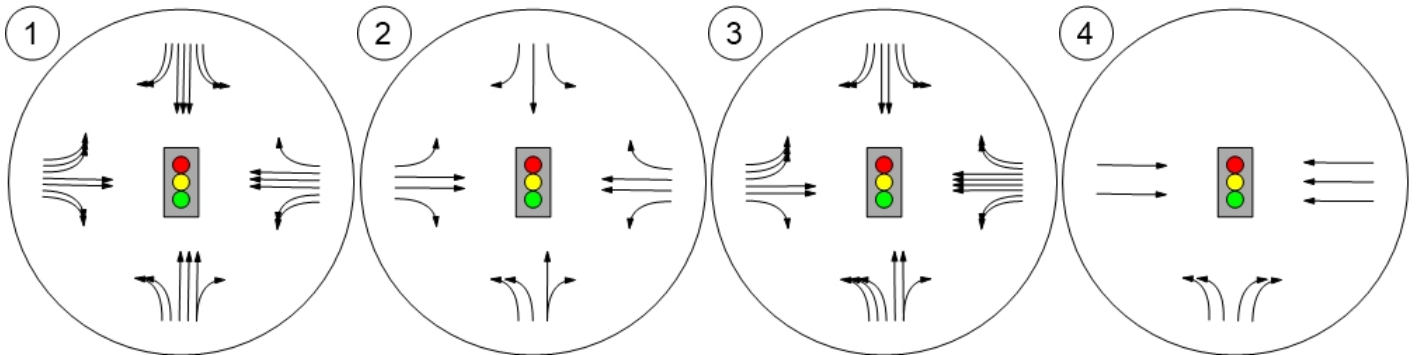

Santa Rita Rd & I-580 EB Ra Tassajara Road & Fallon Roa Fallon Road & Positano Park Fallon Road & Central Parkw

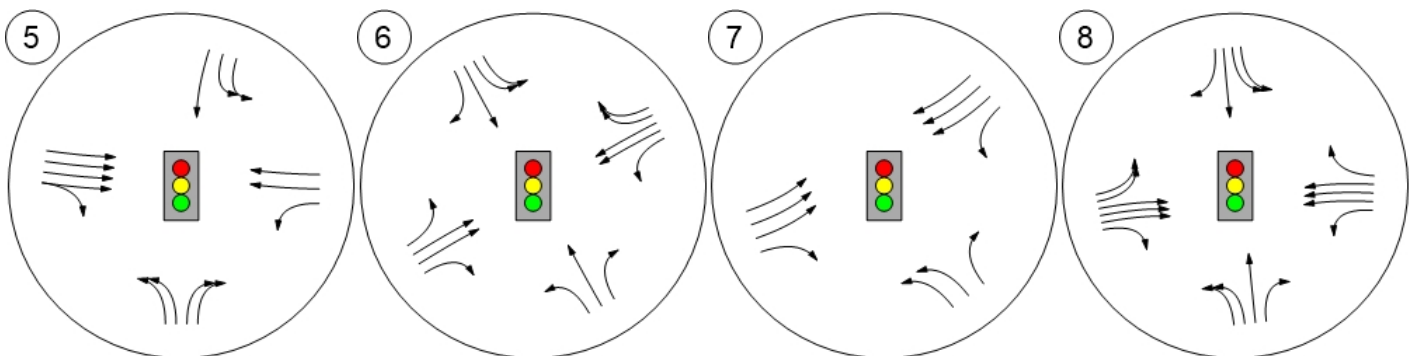

Lane Configuration and Traffic Control

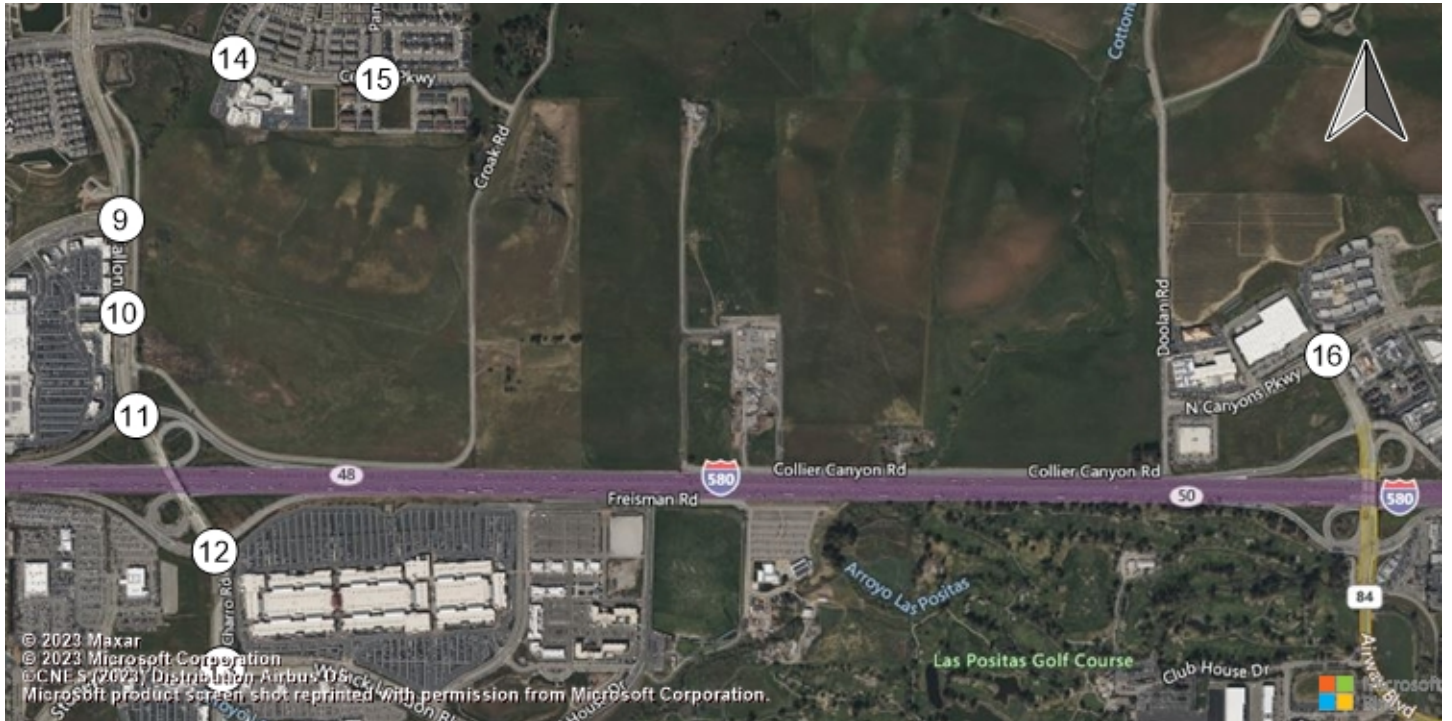

Fallon Road & Dublin Boulevard Fallon Road & Fallon Gateway Fallon Road & I-580 WB Ramp El Charro Road & I-580 EB R

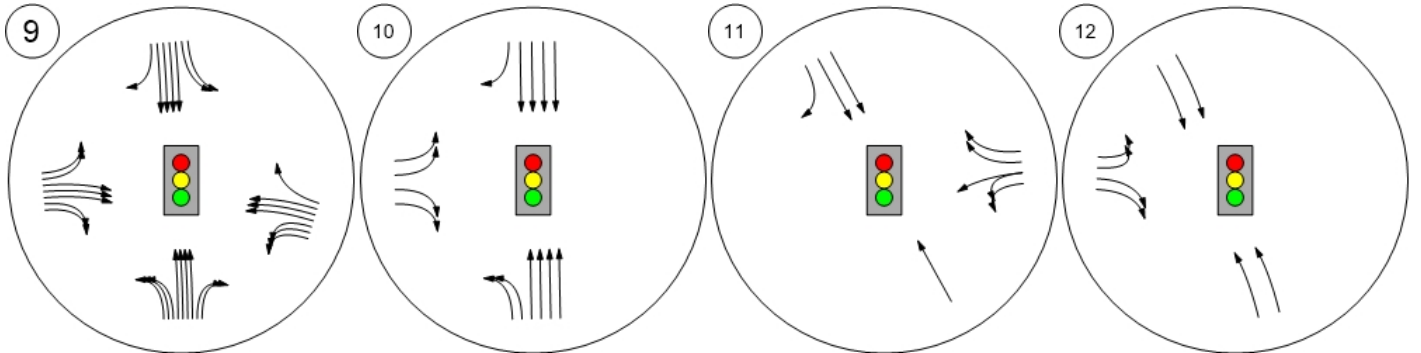

El Charro Road & Jack Lond Central Parkway & Sunset Vi Central Parkway & Panorama Airway Boulevard & N. Canyo

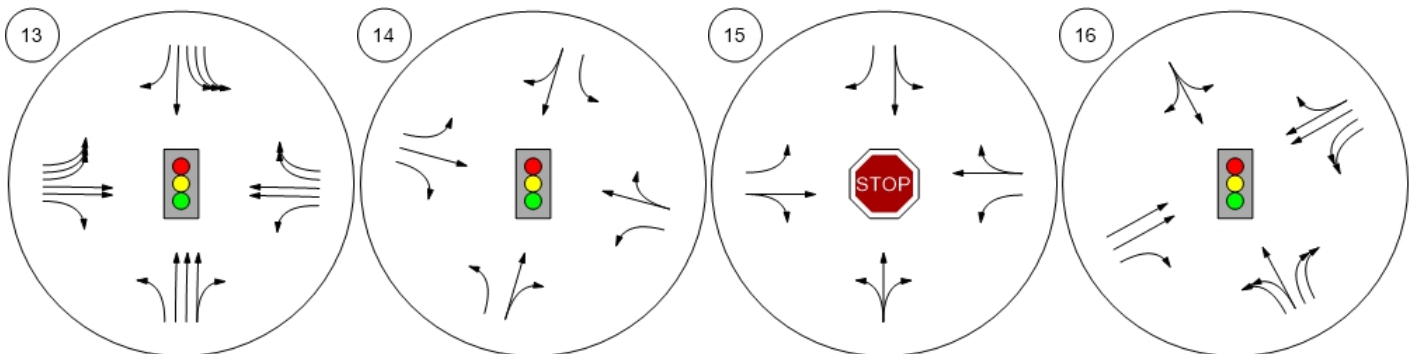

Lane Configuration and Traffic Control

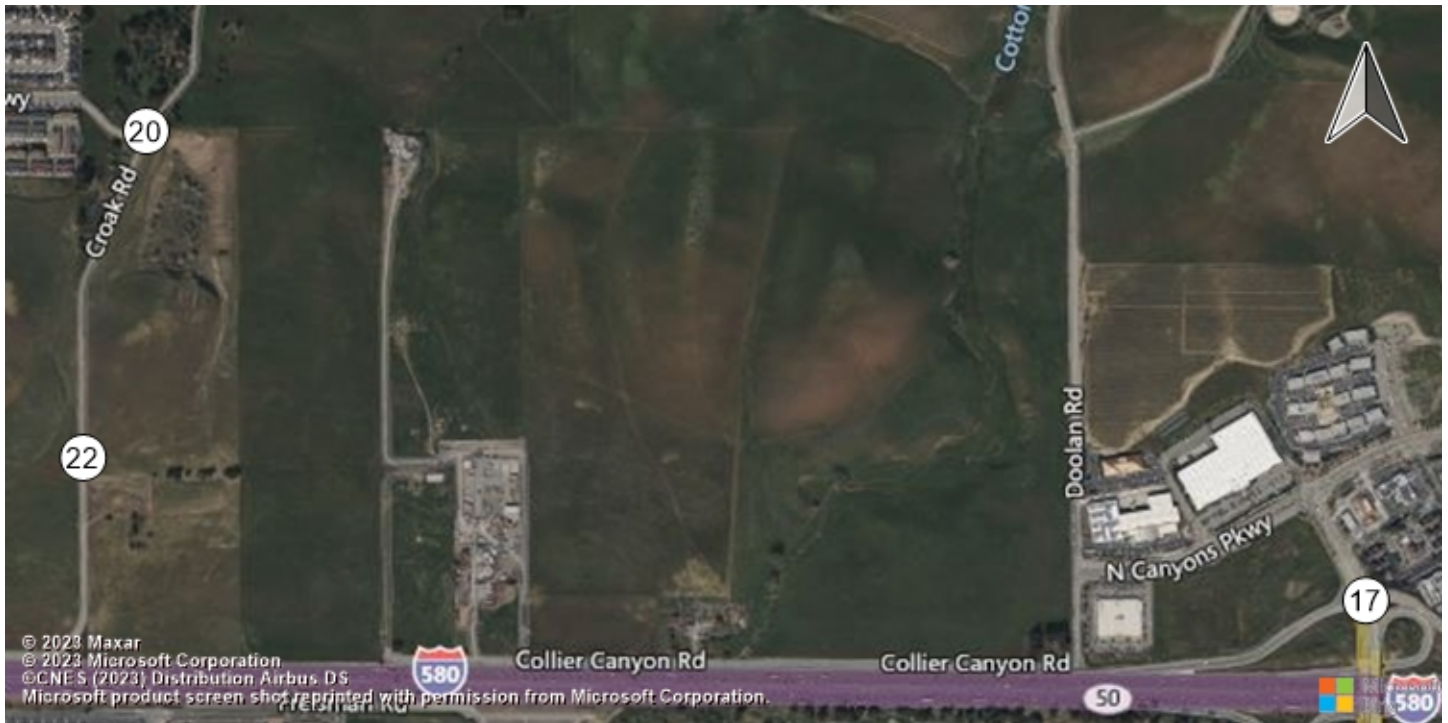

Airway Boulevard & I-580 WB Croak Road & Central Parkw Croak Road & Dublin Boulev

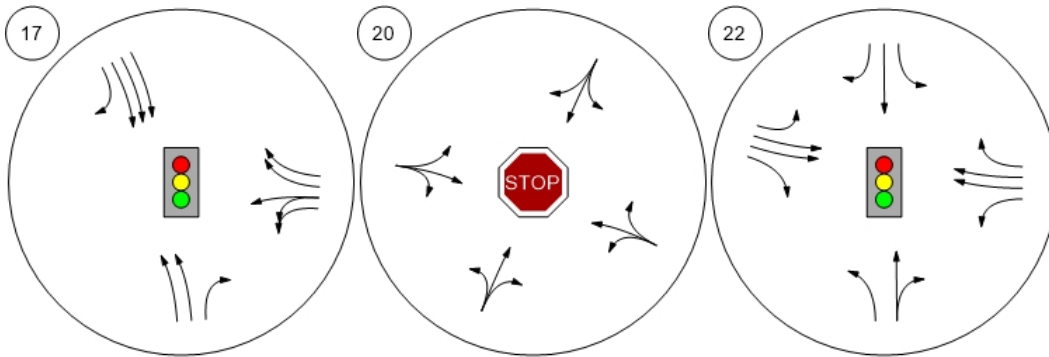



Traffic Volume - Base Volume

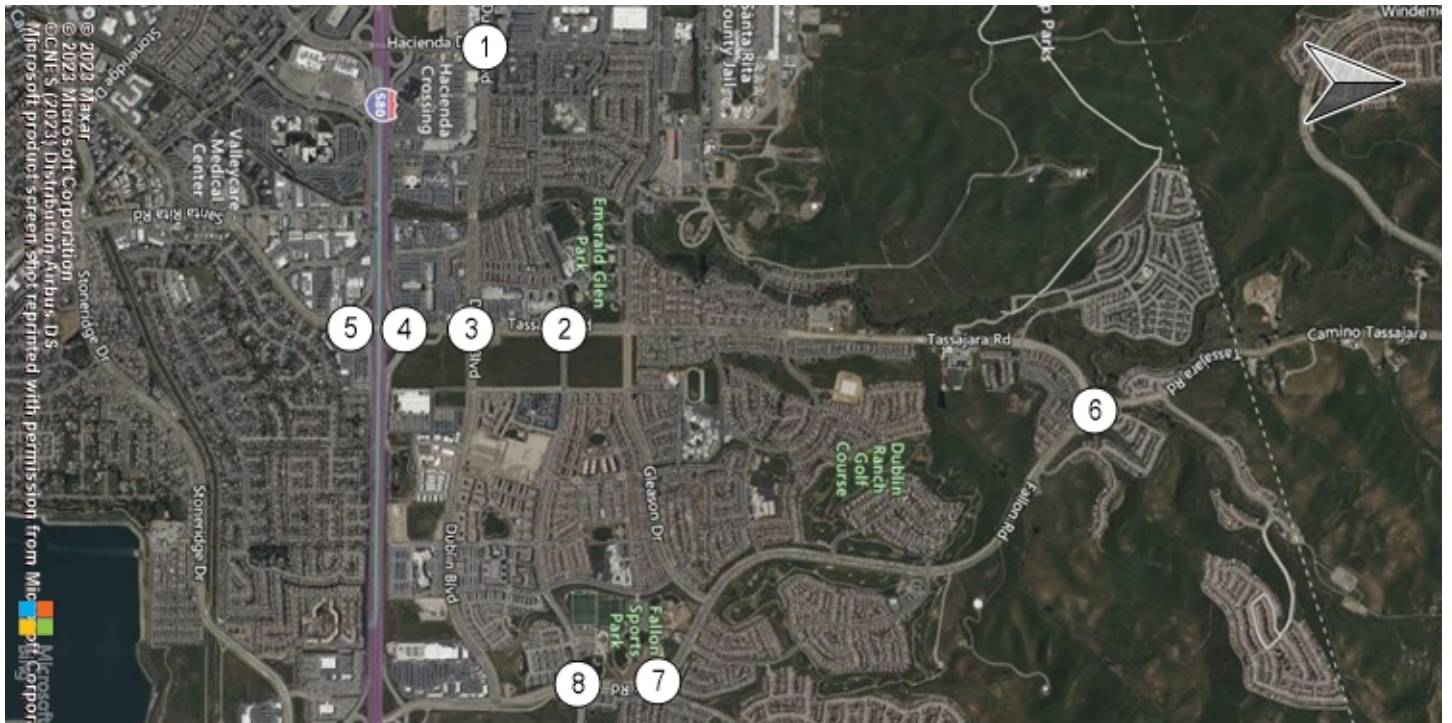

Hacienda Drive & Dublin Boul Tassajara Road & Central Pa Tassajara Road & Dublin Bou Tassajara Road & I-580 WB

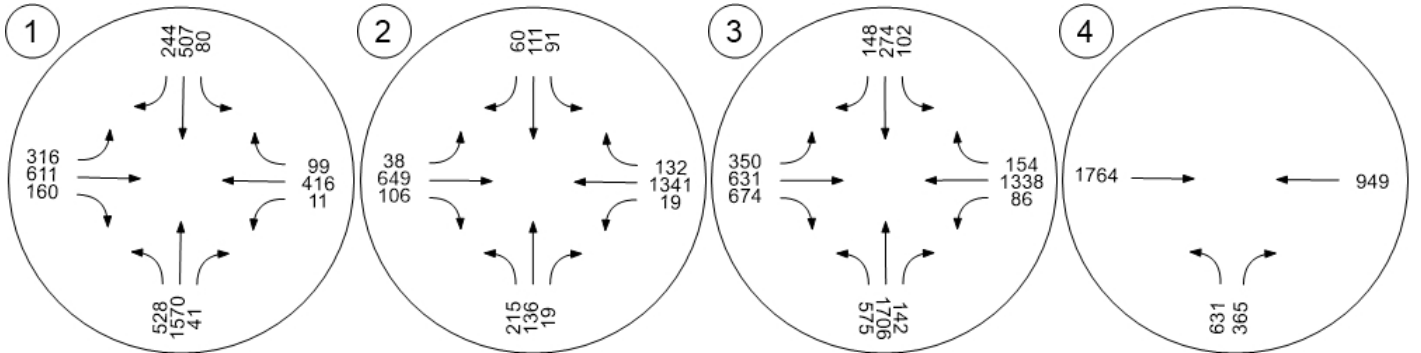

Santa Rita Rd & I-580 EB Ra Tassajara Road & Fallon Roa Fallon Road & Positano Park Fallon Road & Central Parkw

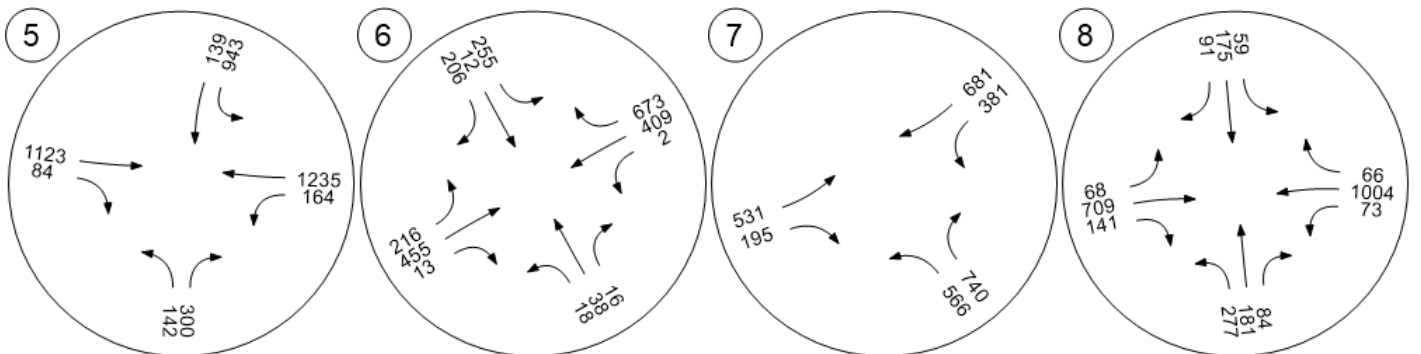

Traffic Volume - Base Volume

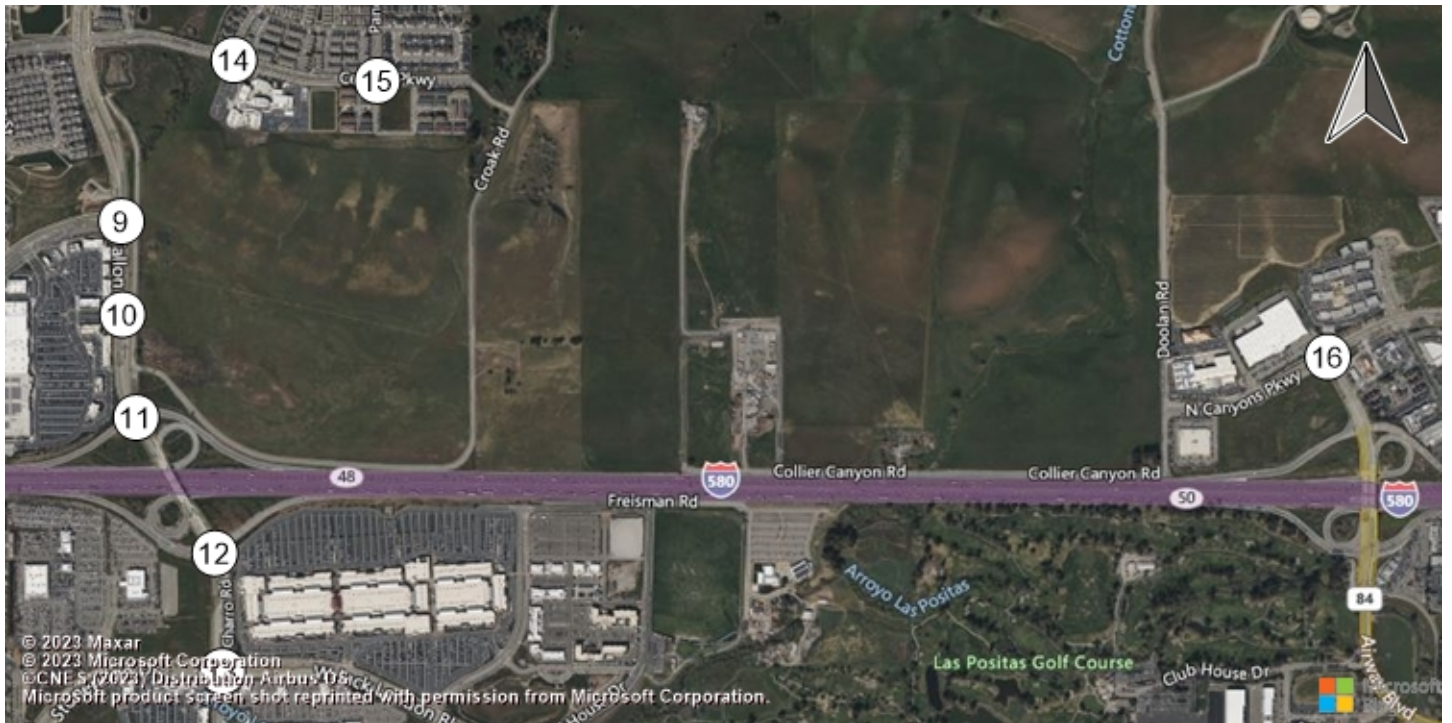

Fallon Road & Dublin Boulevard Fallon Road & Fallon Gateway Fallon Road & I-580 WB Ramp El Charro Road & I-580 EB Ramp

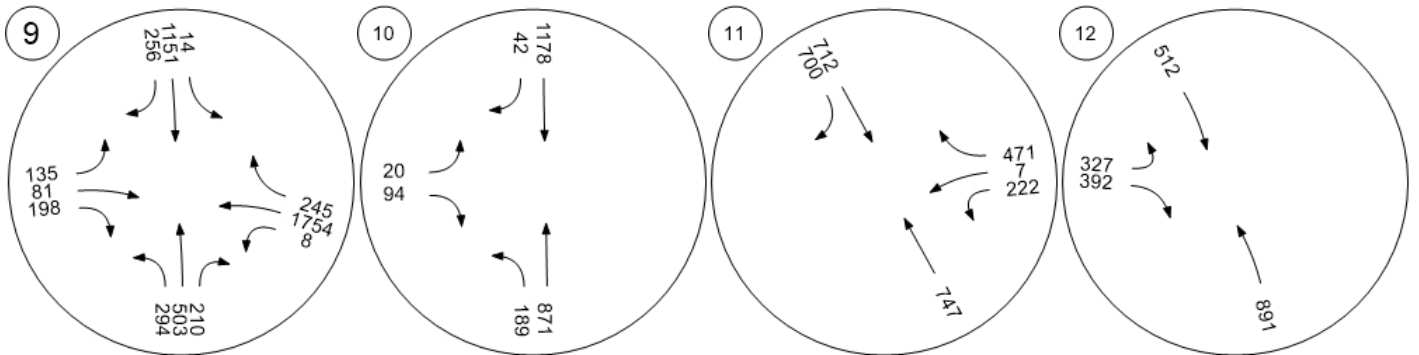

El Charro Road & Jack London Central Parkway & Sunset Vi Central Parkway & Panorama Airway Boulevard & N. Canyon

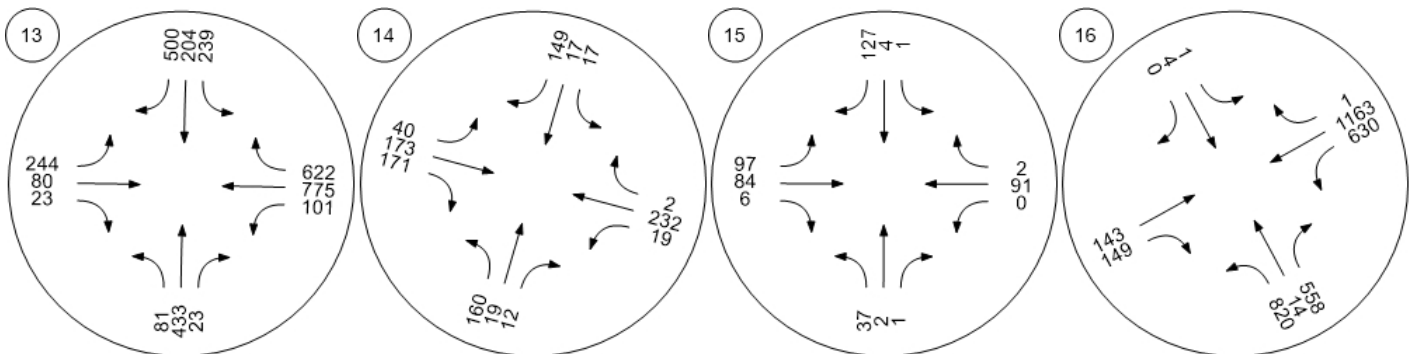



Traffic Volume - Base Volume



Airway Boulevard & I-580 WB Croak Road & Central Parkw Croak Road & Dublin Boulev

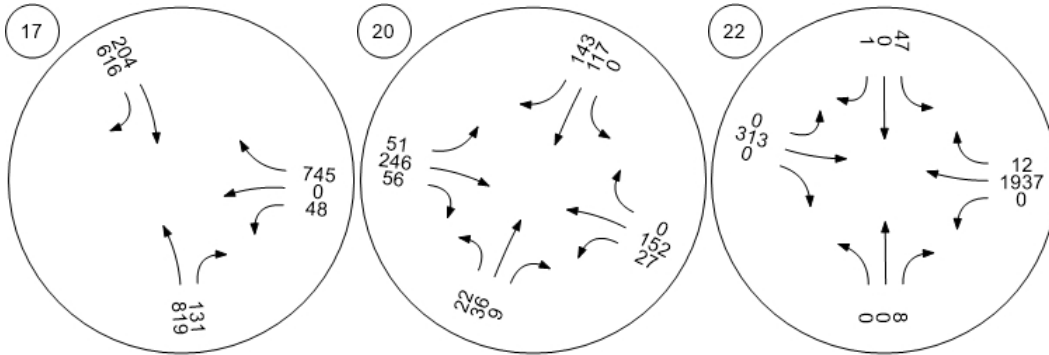

Lane Configuration and Traffic Control

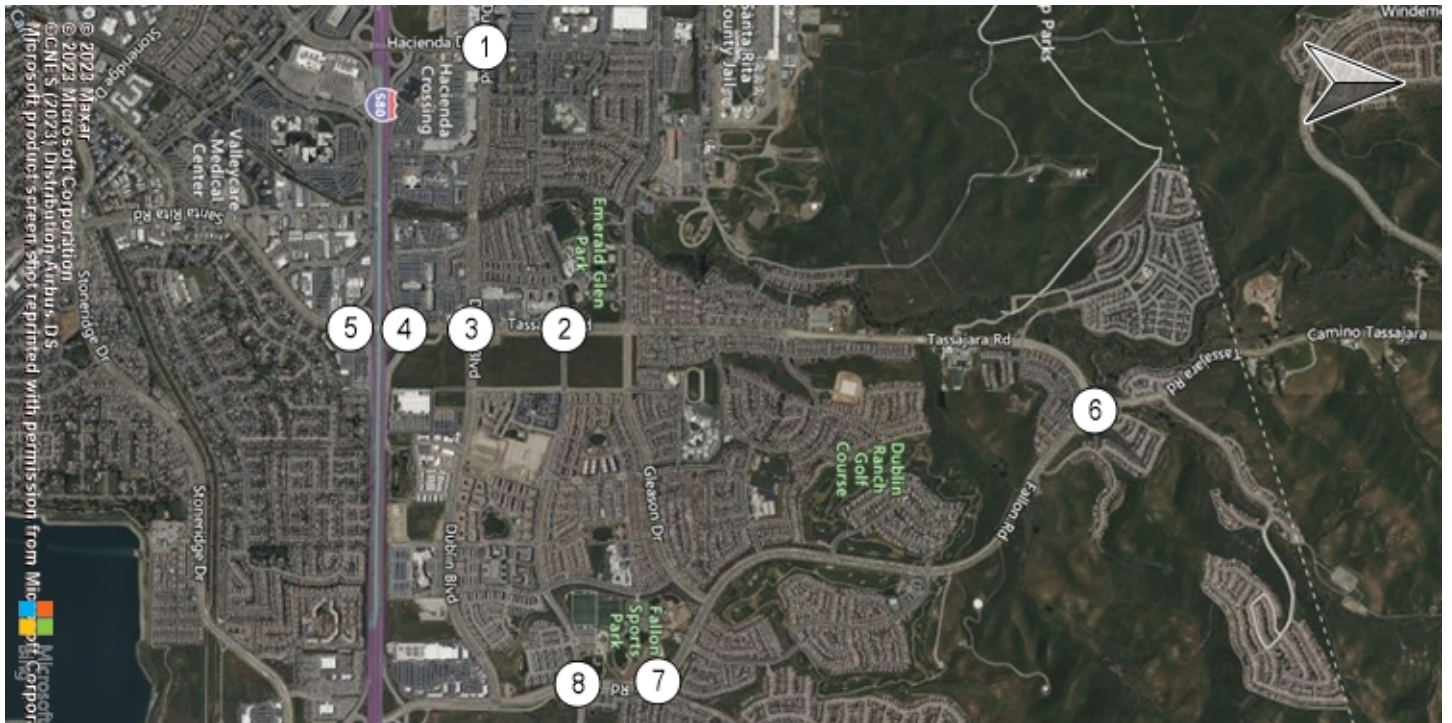

Hacienda Drive & Dublin Boul Tassajara Road & Central Pa Tassajara Road & Dublin Bou Tassajara Road & I-580 WB

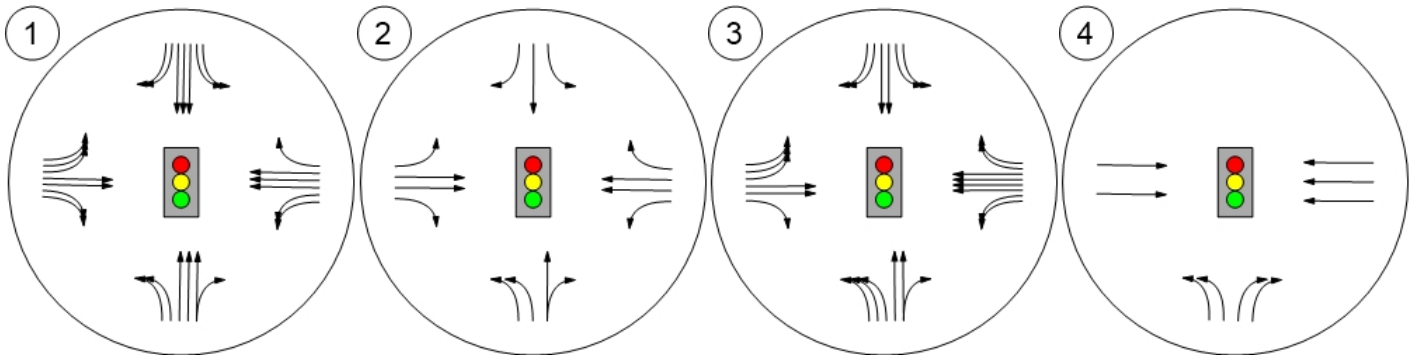

Santa Rita Rd & I-580 EB Ra Tassajara Road & Fallon Roa Fallon Road & Positano Park Fallon Road & Central Parkw

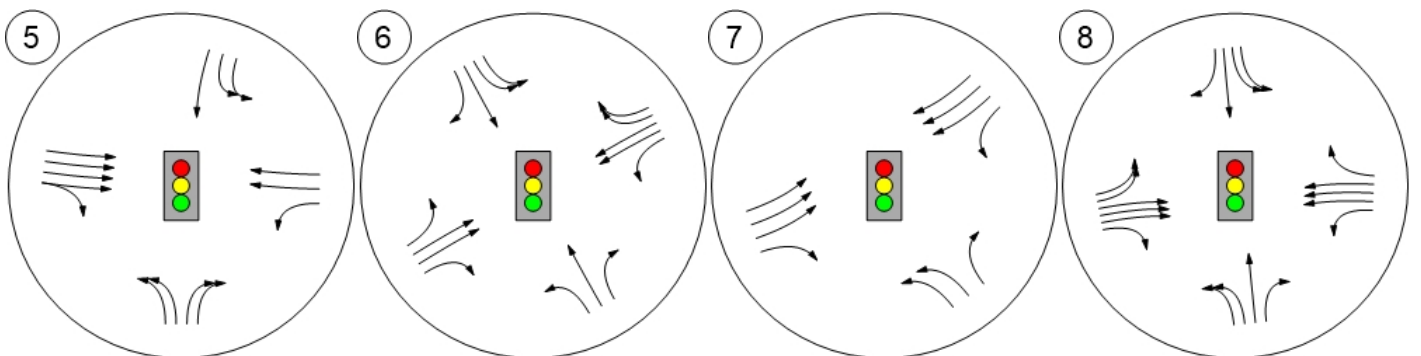

Lane Configuration and Traffic Control

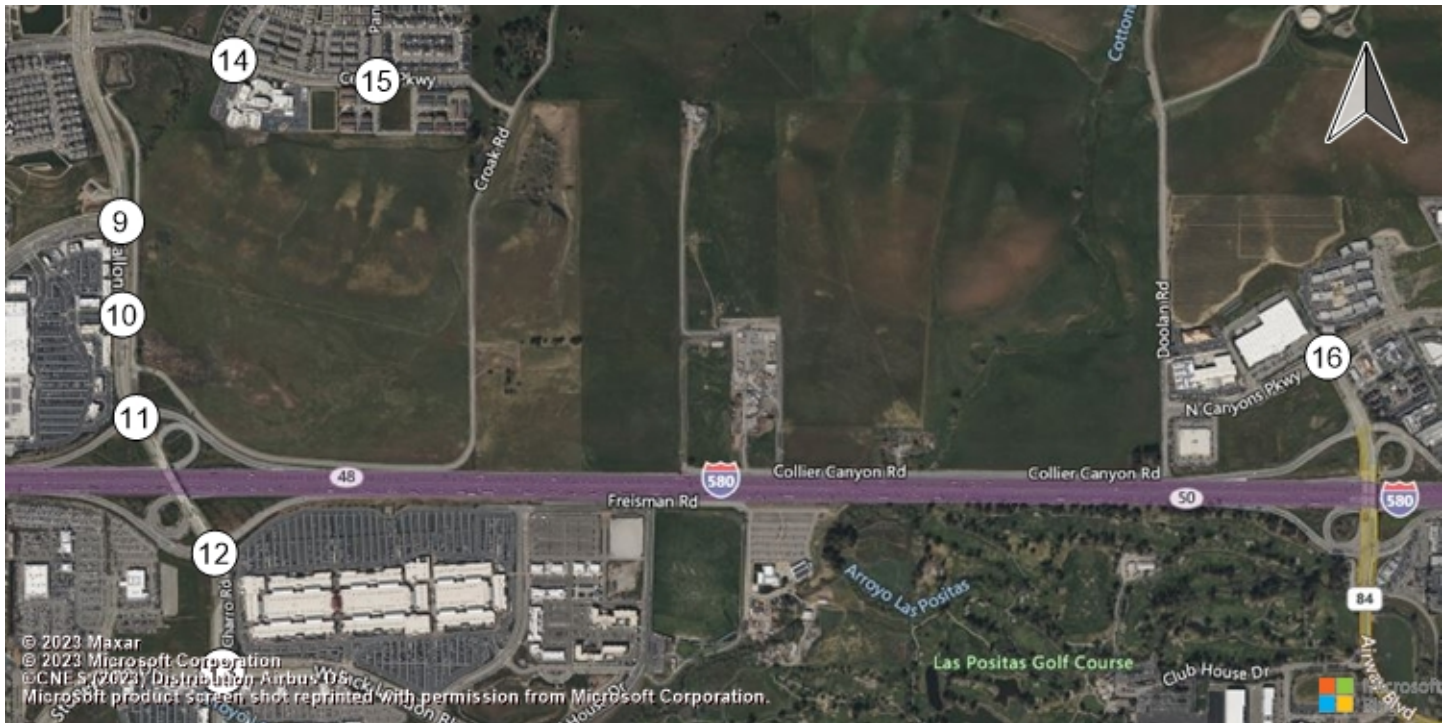

Fallon Road & Dublin Boulevard Fallon Road & Fallon Gateway Fallon Road & I-580 WB Ramp El Charro Road & I-580 EB R

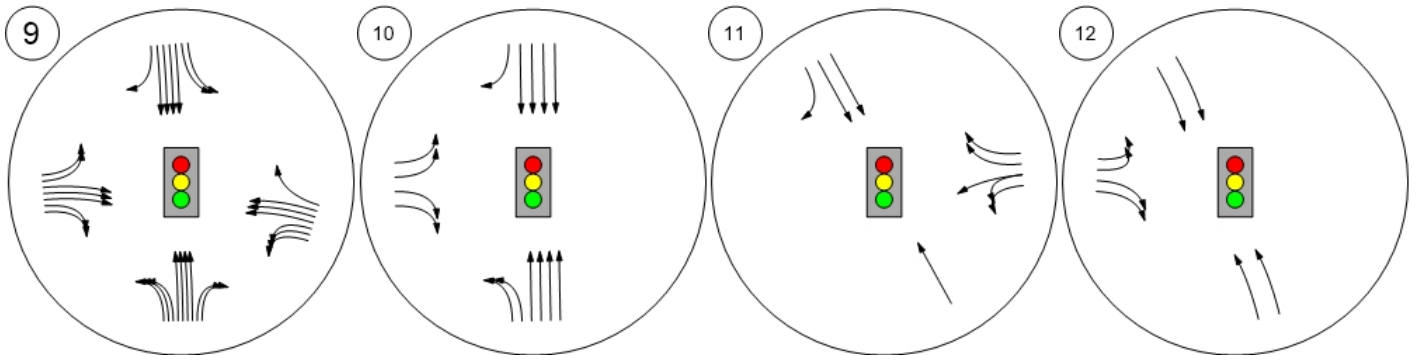

El Charro Road & Jack Lond Central Parkway & Sunset Vi Central Parkway & Panorama Airway Boulevard & N. Canyo

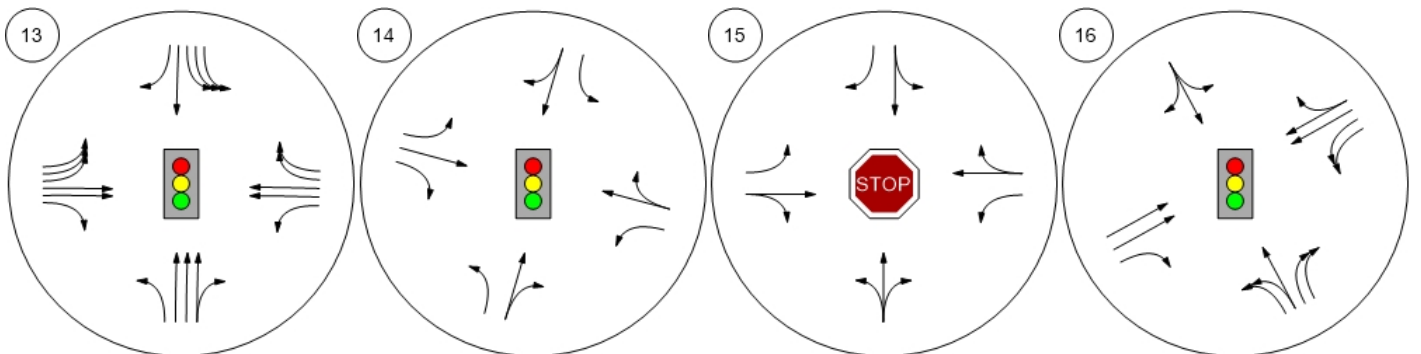



### Lane Configuration and Traffic Control

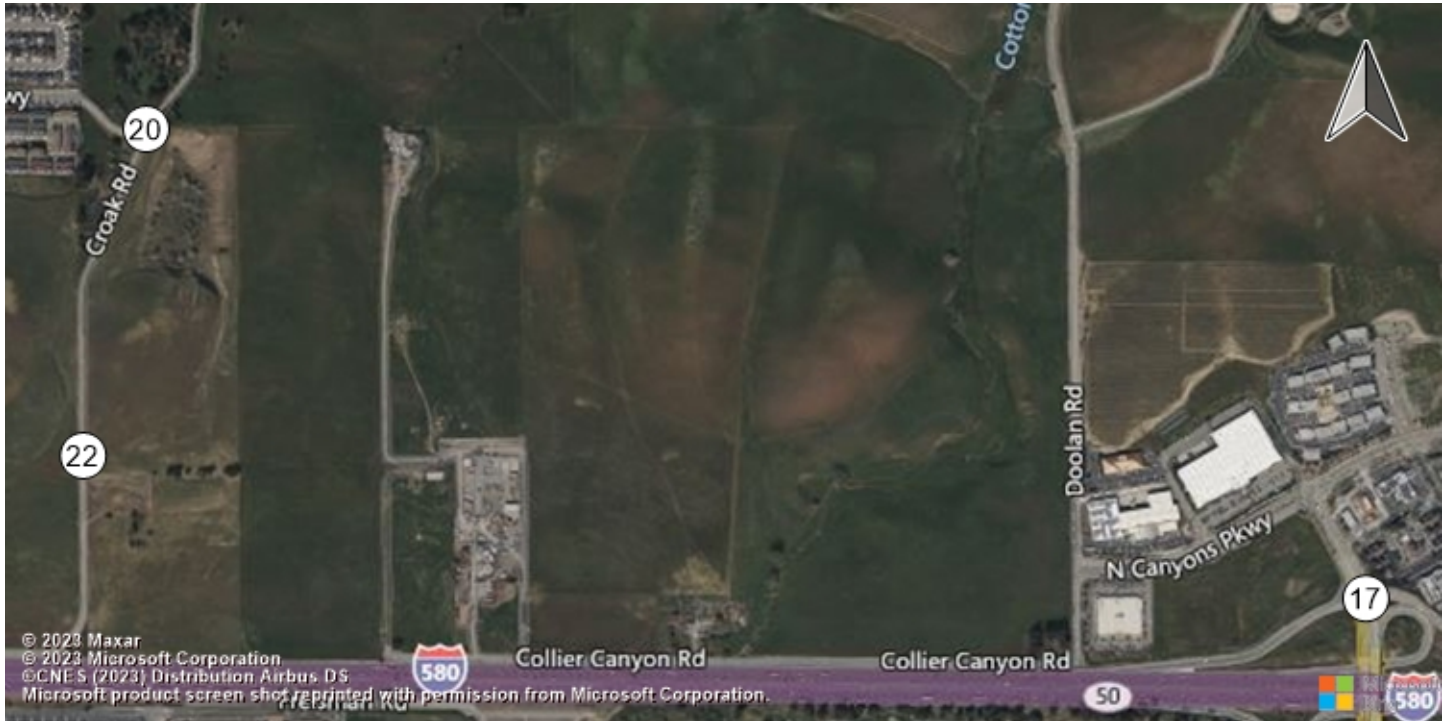

### Airway Boulevard & I-580 WB Croak Road & Central Parkw Croak Road & Dublin Boulev

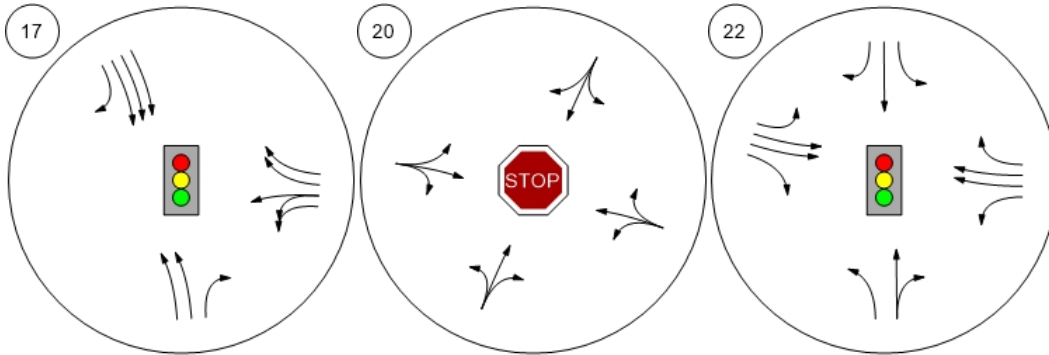

Traffic Volume - Base Volume

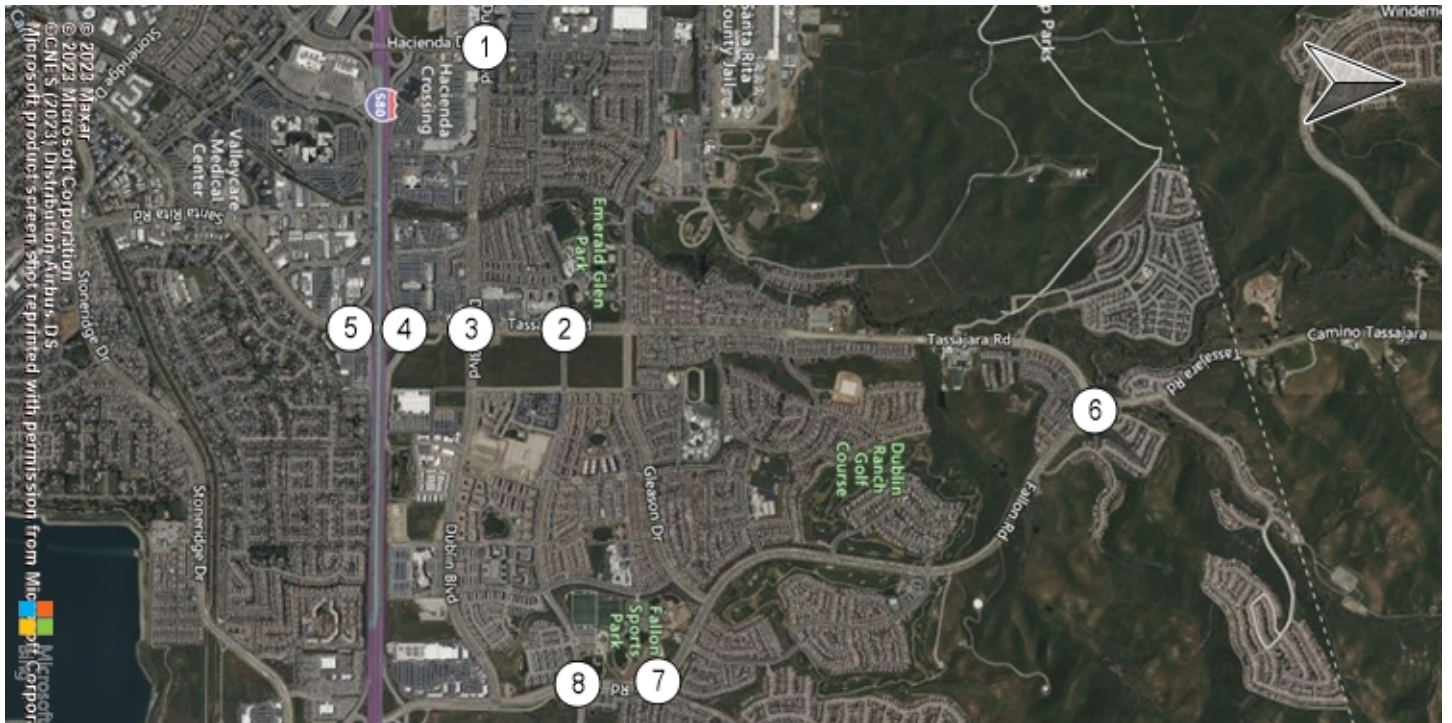

Hacienda Drive & Dublin Boul Tassajara Road & Central Pa Tassajara Road & Dublin Bou Tassajara Road & I-580 WB

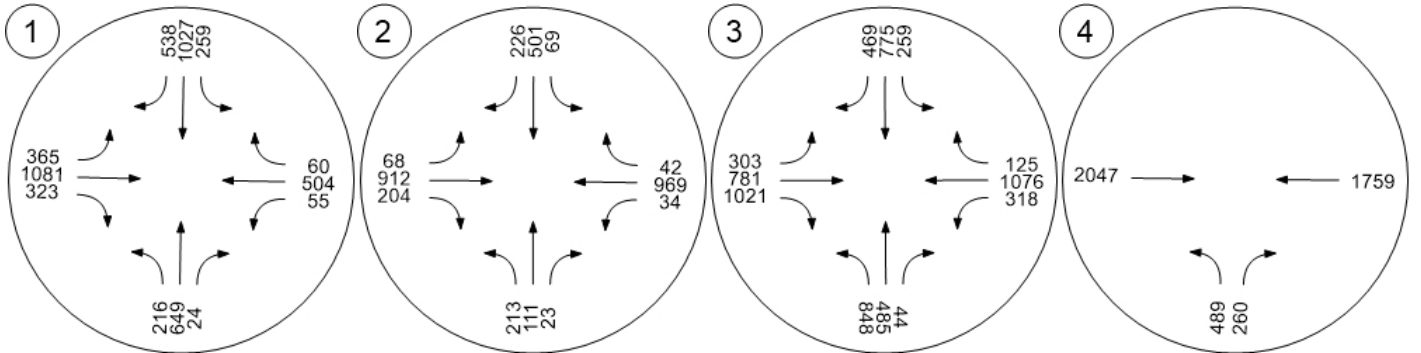

Santa Rita Rd & I-580 EB Ra Tassajara Road & Fallon Roa Fallon Road & Positano Park Fallon Road & Central Parkw

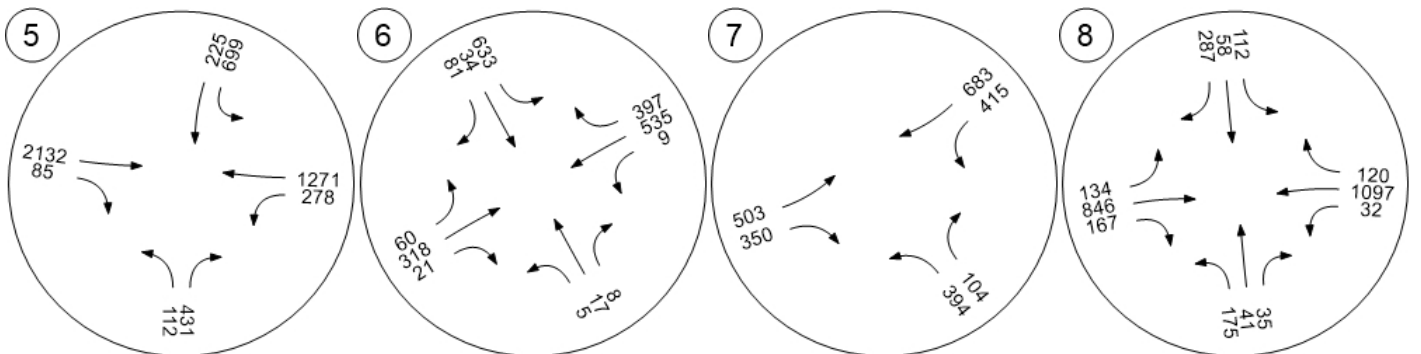



Traffic Volume - Base Volume

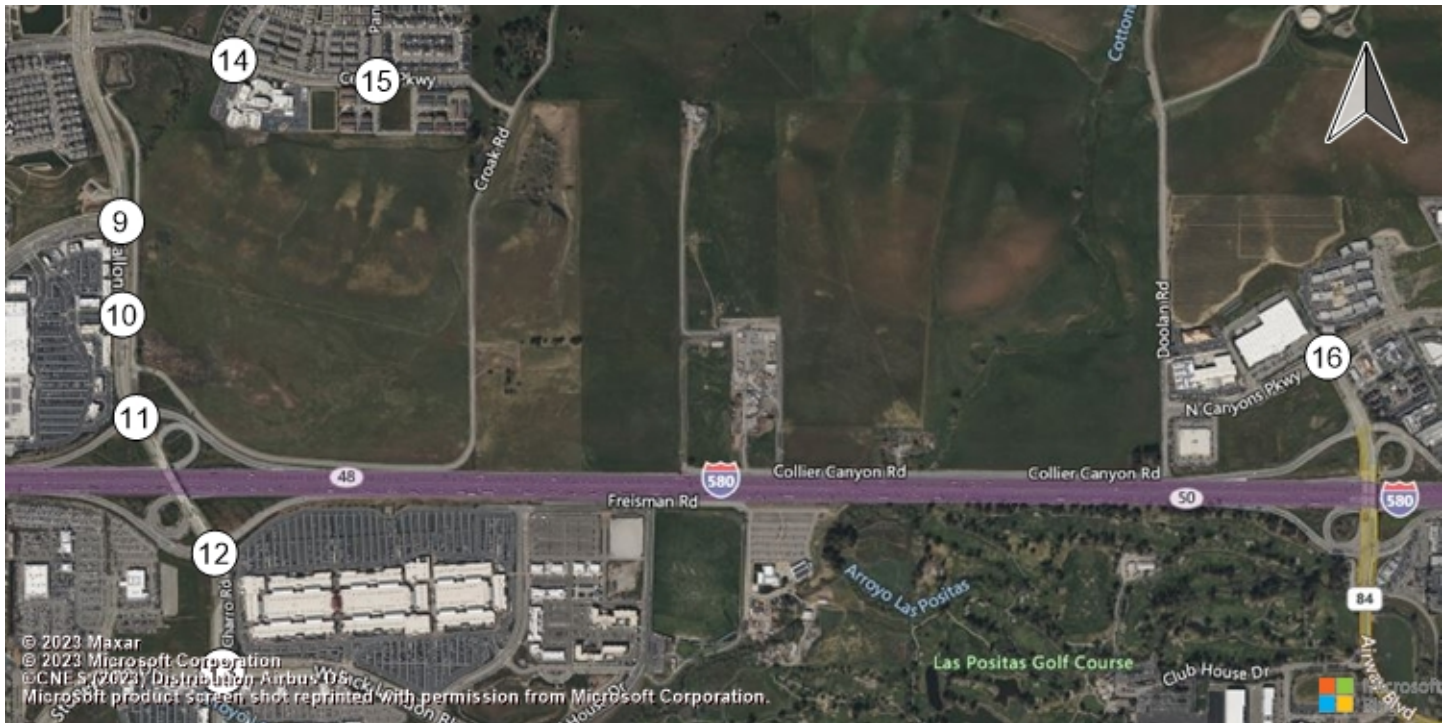

Fallon Road & Dublin Boulevard Fallon Road & Fallon Gateways Fallon Road & I-580 WB Ram El Charro Road & I-580 EB R

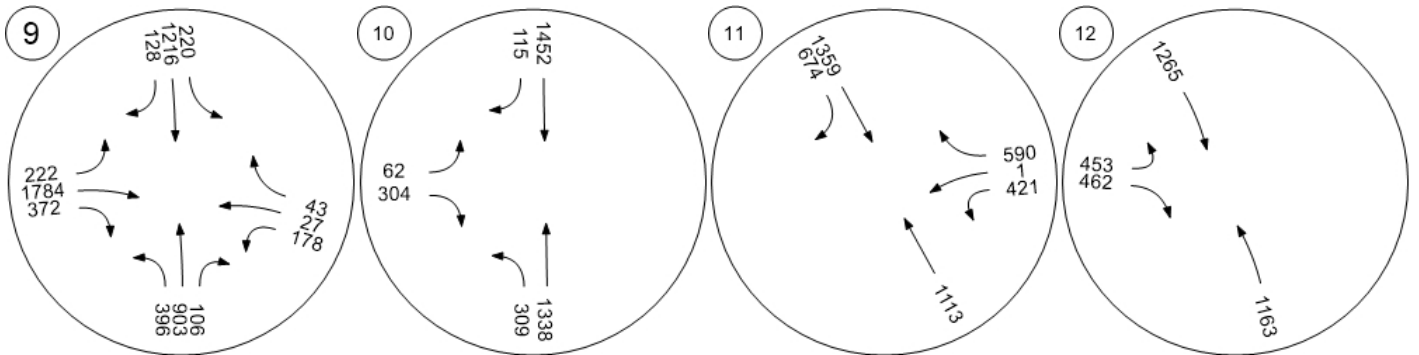

El Charro Road & Jack Lond Central Parkway & Sunset Vi Central Parkway & Panorama Airway Boulevard & N. Canyo

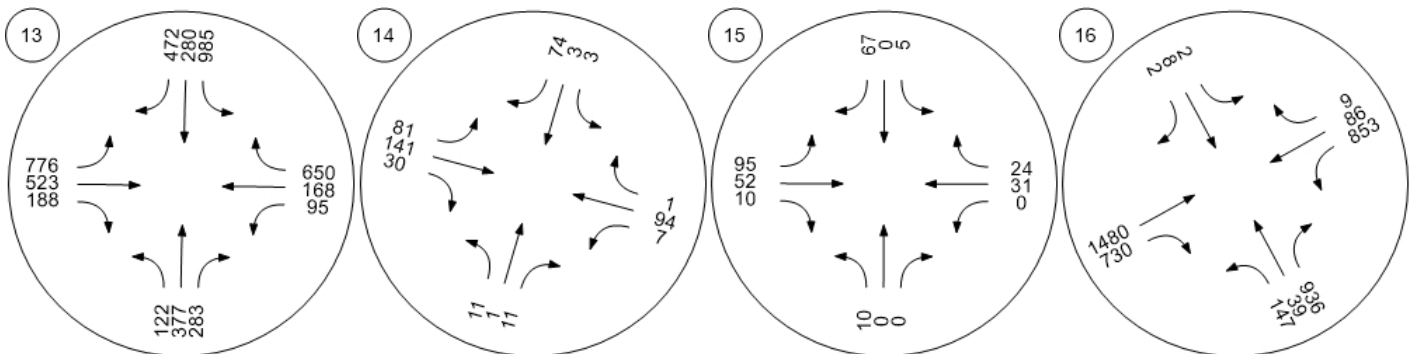

Traffic Volume - Base Volume

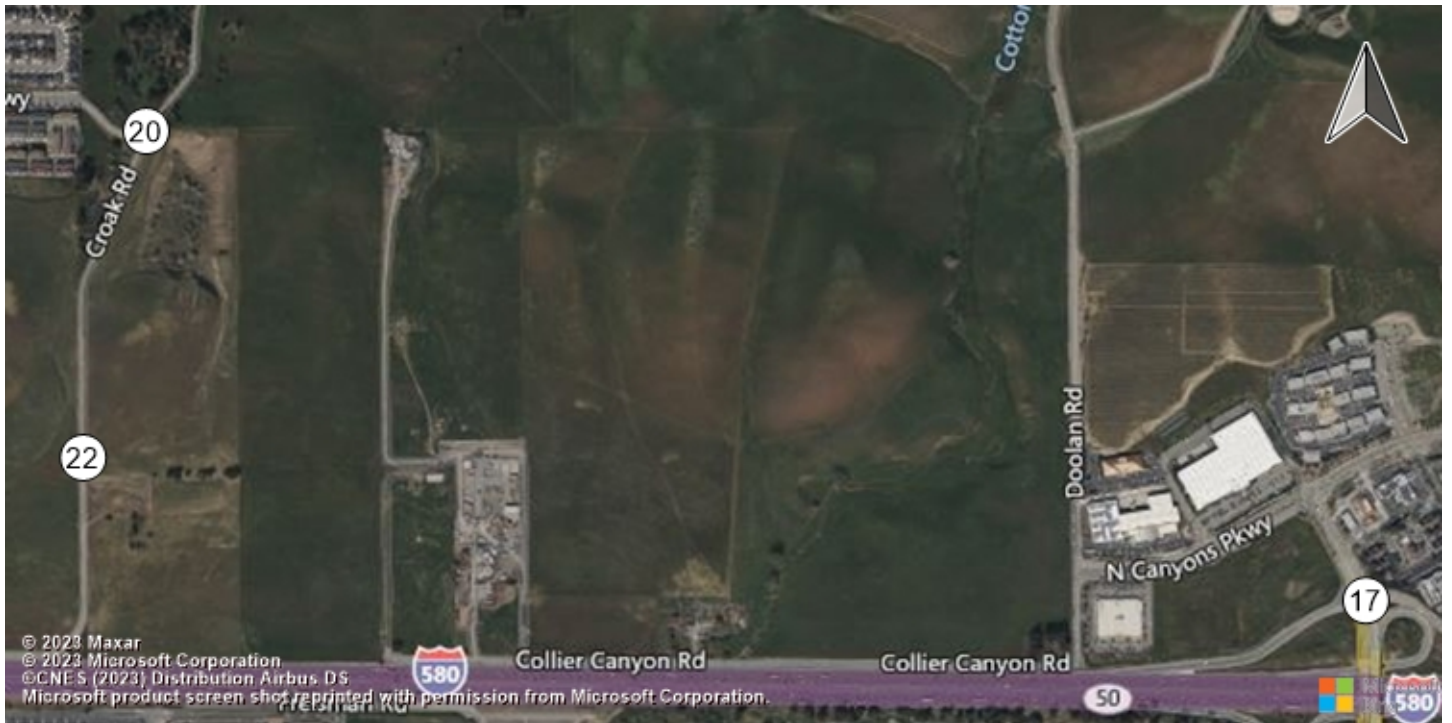

Airway Boulevard & I-580 WB Croak Road & Central Parkw Croak Road & Dublin Boulev

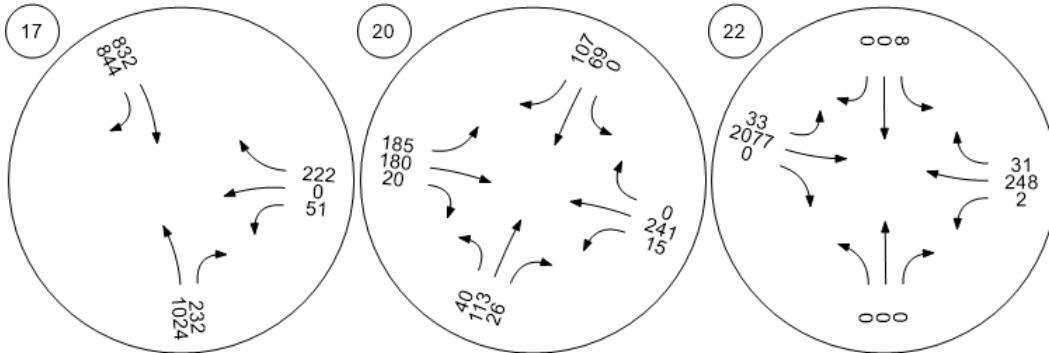



## Appendix I: Cumulative Operational Outputs

Vistro File: H:\...\PacVest\_20240329.vistro  
 Report File: H:\...\CumulativeAM\_LOS.pdf

Scenario 7 Cumulative AM  
 3/29/2024

**Intersection Analysis Summary**

ID	Intersection Name	Control Type	Method	Worst Mvmt	V/C	Delay (s/veh)	LOS
1	Hacienda Drive & Dublin Boulevard	Signalized	HCM 7th Edition	WB Left	0.569	64.8	E
2	Tassajara Road & Central Parkway	Signalized	HCM 7th Edition	SB Left	0.640	29.3	C
3	Tassajara Road & Dublin Boulevard	Signalized	HCM 7th Edition	WB Right	1.192	178.7	F
4	Tassajara Road & I-580 WB Ramps	Signalized	HCM 7th Edition	WB Left	0.764	15.2	B
5	Santa Rita Rd & I-580 EB Ramps/Pimlico Dr	Signalized	HCM 7th Edition	SB Left	0.814	36.4	D
6	Tassajara Road & Fallon Road	Signalized	HCM 7th Edition	SB Left	0.733	26.7	C
7	Fallon Road & Positano Parkway	Signalized	HCM 7th Edition	WB Right	1.087	94.2	F
8	Fallon Road & Central Parkway	Signalized	HCM 7th Edition	SB Left	0.585	32.8	C
9	Fallon Road & Dublin Boulevard	Signalized	HCM 7th Edition	WB Left	0.703	43.7	D
10	Fallon Road & Fallon Gateway	Signalized	HCM 7th Edition	NB Left	0.332	9.6	A
11	Fallon Road & I-580 WB Ramps	Signalized	HCM 7th Edition	NB Thru	0.710	13.5	B
12	El Charro Road & I-580 EB Ramps	Signalized	HCM 7th Edition	EB Right	0.687	7.5	A
13	El Charro Road & Jack London Boulevard	Signalized	HCM 7th Edition	NB Right	0.748	41.7	D
14	Central Parkway & Sunset View Drive	Signalized	HCM 7th Edition	EB Right	0.786	33.4	C
15	Central Parkway & Panorama Drive/Pino Grande Road	All-way stop	HCM 7th Edition	EB Left	0.359	11.0	B
16	Airway Boulevard & N. Canyons Parkway	Signalized	HCM 7th Edition	SB Thru	0.688	23.8	C
17	Airway Boulevard & I-580 WB Ramps	Signalized	HCM 7th Edition	WB Right	0.472	64.2	E
	Creek Road & Central Parkway	Signalized	HCM 7th Edition	WB Right			



Version 2024 (SP 0-1)

20	Croak Road & Central Parkway	All-way stop	HCM 7th Edition	EB Thru	0.495	11.6	B
22	Croak Road & Dublin Boulevard	Signalized	HCM 7th Edition	SB Left	0.622	21.1	C

V/C, Delay, LOS: For two-way stop, these values are taken from the movement with the worst (highest) delay value. For all other control types, they are taken for the whole intersection.

**Intersection Level Of Service Report**  
**Intersection 1: Hacienda Drive & Dublin Boulevard**

Control Type:	Signalized	Delay (sec / veh):	64.8
Analysis Method:	HCM 7th Edition	Level Of Service:	E
Analysis Period:	15 minutes	Volume to Capacity (v/c):	0.569

**Intersection Setup**

Name	Hacienda Drive			Hacienda Drive			Dublin Boulevard			Dublin Boulevard		
Approach	Northbound			Southbound			Eastbound			Westbound		
Lane Configuration	[Diagram]			[Diagram]			[Diagram]			[Diagram]		
Turning Movement	Left	Thru	Right	Left	Thru	Right	Left	Thru	Right	Left	Thru	Right
Lane Width [ft]	12.00	12.00	12.00	12.00	12.00	12.00	12.00	12.00	12.00	12.00	12.00	12.00
No. of Lanes in Entry Pocket	2	0	2	2	0	1	2	0	2	2	0	0
Entry Pocket Length [ft]	250.00	100.00	380.00	300.00	100.00	220.00	300.00	100.00	250.00	275.00	100.00	100.00
No. of Lanes in Exit Pocket	0	0	0	0	0	0	0	0	0	0	0	1
Exit Pocket Length [ft]	0.00	0.00	0.00	0.00	0.00	0.00	0.00	0.00	0.00	0.00	0.00	1000.00
Speed [mph]	35.00			35.00			40.00			40.00		
Grade [%]	0.00			0.00			0.00			0.00		
Curb Present	Yes			Yes			Yes			Yes		
Crosswalk	Yes			Yes			Yes			Yes		





**Volumes**

Name	Hacienda Drive			Hacienda Drive			Dublin Boulevard			Dublin Boulevard		
Base Volume Input [veh/h]	316	611	160	11	416	99	80	507	244	528	1570	41
Base Volume Adjustment Factor	1.0000	1.0000	1.0000	1.0000	1.0000	1.0000	1.0000	1.0000	1.0000	1.0000	1.0000	1.0000
Heavy Vehicles Percentage [%]	3.40	1.10	1.90	0.00	1.50	4.50	5.20	1.70	8.60	0.50	2.30	4.80
Proportion of CAVs [%]	0.00											
Growth Factor	1.0000	1.0000	1.0000	1.0000	1.0000	1.0000	1.0000	1.0000	1.0000	1.0000	1.0000	1.0000
In-Process Volume [veh/h]	0	0	0	0	0	0	0	0	0	0	0	0
Site-Generated Trips [veh/h]	0	0	0	0	0	0	0	0	0	0	0	0
Diverted Trips [veh/h]	0	0	0	0	0	0	0	0	0	0	0	0
Pass-by Trips [veh/h]	0	0	0	0	0	0	0	0	0	0	0	0
Existing Site Adjustment Volume [veh/h]	0	0	0	0	0	0	0	0	0	0	0	0
Other Volume [veh/h]	0	0	0	0	0	0	0	0	0	0	0	0
Right Turn on Red Volume [veh/h]	0	0	0	0	0	0	0	0	0	0	0	0
Total Hourly Volume [veh/h]	316	611	160	11	416	99	80	507	244	528	1570	41
Peak Hour Factor	0.9500	0.9500	0.9500	0.9500	0.9500	0.9500	0.9500	0.9500	0.9500	0.9500	0.9500	0.9500
Other Adjustment Factor	1.0000	1.0000	1.0000	1.0000	1.0000	1.0000	1.0000	1.0000	1.0000	1.0000	1.0000	1.0000
Total 15-Minute Volume [veh/h]	83	161	42	3	109	26	21	133	64	139	413	11
Total Analysis Volume [veh/h]	333	643	168	12	438	104	84	534	257	556	1653	43
Presence of On-Street Parking	No		No	No		No	No		No	No		No
On-Street Parking Maneuver Rate [/h]	0	0	0	0	0	0	0	0	0	0	0	0
Local Bus Stopping Rate [/h]	0	0	0	0	0	0	0	0	0	0	0	0
v_do, Outbound Pedestrian Volume crossing	1			3			0			2		
v_di, Inbound Pedestrian Volume crossing m	0			2			1			3		
v_co, Outbound Pedestrian Volume crossing	0			2			3			1		
v_ci, Inbound Pedestrian Volume crossing mi	1			3			2			0		
v_ab, Corner Pedestrian Volume [ped/h]	0			0			0			0		
Bicycle Volume [bicycles/h]	0			0			0			1		



**Intersection Settings**

Located in CBD	No
Signal Coordination Group	-
Cycle Length [s]	150
Active Pattern	Pattern 1
Coordination Type	Time of Day Pattern Coordinated
Actuation Type	Fully actuated
Offset [s]	57.0
Offset Reference	Lead Green - Beginning of First Green
Permissive Mode	SingleBand
Lost time [s]	12.00

**Phasing & Timing (Basic)**

Control Type	Protecte	Permiss	Permiss	Protecte	Permiss	Permiss	Protecte	Permiss	Permiss	Protecte	Permiss	Permiss
Signal Group	3	8	0	7	4	0	5	2	0	1	6	0
Auxiliary Signal Groups												
Maximum Green [s]	20	50	0	20	50	0	20	60	0	20	60	0
Amber [s]	3.5	4.5	0.0	3.5	4.1	0.0	3.5	4.5	0.0	3.5	4.5	0.0
All red [s]	1.5	1.5	0.0	1.0	1.5	0.0	1.0	1.5	0.0	1.0	1.5	0.0
Walk [s]	0	4	0	0	4	0	0	4	0	0	4	0
Pedestrian Clearance [s]	0	32	0	0	40	0	0	43	0	0	35	0
Delayed Vehicle Green [s]	0.0	0.0	0.0	0.0	0.0	0.0	0.0	0.0	0.0	0.0	0.0	0.0
Rest In Walk		No			No			No			No	
I1, Start-Up Lost Time [s]	2.0	2.0	0.0	2.0	2.0	0.0	2.0	2.0	0.0	2.0	2.0	0.0
I2, Clearance Lost Time [s]	2.0	2.0	0.0	2.0	2.0	0.0	2.0	2.0	0.0	2.0	2.0	0.0
Detector Location [ft]	0.0	0.0	0.0	0.0	0.0	0.0	0.0	0.0	0.0	0.0	0.0	0.0
Detector Length [ft]	20.0	20.0	0.0	20.0	20.0	0.0	20.0	20.0	0.0	20.0	20.0	0.0
I, Upstream Filtering Factor	1.00	1.00	1.00	1.00	1.00	1.00	1.00	1.00	1.00	1.00	1.00	1.00

**Phasing & Timing: Pattern 1**

Split [s]	18	55	0	14	51	0	15	61	0	20	66	0
Lead / Lag	Lead	-	-	Lead	-	-	Lead	-	-	Lead	-	-
Minimum Green [s]	4	10	0	4	10	0	4	10	0	8	10	0
Vehicle Extension [s]	3.0	3.5	0.0	3.0	3.5	0.0	3.0	3.5	0.0	3.0	3.5	0.0
Minimum Recall	No	No		No	No		No	Yes		No	Yes	
Maximum Recall	No	No		No	No		No	No		No	No	
Pedestrian Recall	No	No		No	No		No	No		No	No	

**Exclusive Pedestrian Phase**

Pedestrian Signal Group	0
Pedestrian Walk [s]	0
Pedestrian Clearance [s]	0



**Lane Group Calculations**

Lane Group	L	C	R	L	C	R	L	C	R	L	C	C
C, Cycle Length [s]	150	150	150	150	150	150	150	150	150	150	150	150
L, Total Lost Time per Cycle [s]	4.00	4.00	4.00	4.00	4.00	4.00	4.00	4.00	4.00	4.00	4.00	4.00
l1_p, Permitted Start-Up Lost Time [s]	0.00	0.00	0.00	0.00	0.00	0.00	0.00	0.00	0.00	0.00	0.00	0.00
l2, Clearance Lost Time [s]	2.00	2.00	2.00	2.00	2.00	2.00	2.00	2.00	2.00	2.00	2.00	2.00
g_i, Effective Green Time [s]	13	33	33	2	23	23	6	83	83	16	93	93
g / C, Green / Cycle	0.09	0.22	0.22	0.01	0.15	0.15	0.04	0.55	0.55	0.11	0.62	0.62
(v / s)_i Volume / Saturation Flow Rate	0.06	0.18	0.06	0.00	0.09	0.07	0.02	0.10	0.10	0.16	0.31	0.32
s, saturation flow rate [veh/h]	5130	3586	2812	3514	5114	1542	3370	5106	2663	3500	3552	1839
c, Capacity [veh/h]	437	795	624	50	772	233	138	2811	1466	374	2189	1133
d1, Uniform Delay [s]	67.17	55.37	48.33	73.16	59.16	57.96	70.79	16.93	16.78	67.03	16.10	16.14
k, delay calibration	0.11	0.13	0.13	0.11	0.13	0.13	0.11	0.50	0.50	0.14	0.50	0.50
l, Upstream Filtering Factor	1.00	1.00	1.00	1.00	1.00	1.00	1.00	1.00	1.00	1.00	1.00	1.00
d2, Incremental Delay [s]	2.79	2.42	0.28	2.40	0.79	1.62	4.30	0.15	0.26	223.83	0.85	1.65
d3, Initial Queue Delay [s]	0.00	0.00	0.00	0.00	0.00	0.00	0.00	0.00	0.00	0.00	0.00	0.00
Rp, platoon ratio	1.00	1.00	1.00	1.00	1.00	1.00	1.00	1.00	1.00	1.00	1.00	1.00
PF, progression factor	1.00	1.00	1.00	1.00	1.00	1.00	1.00	1.00	1.00	1.00	1.00	1.00

**Lane Group Results**

X, volume / capacity	0.76	0.81	0.27	0.24	0.57	0.45	0.61	0.19	0.18	1.49	0.51	0.51
d, Delay for Lane Group [s/veh]	69.95	57.79	48.61	75.56	59.95	59.58	75.09	17.08	17.04	290.86	16.95	17.79
Lane Group LOS	E	E	D	E	E	E	E	B	B	F	B	B
Critical Lane Group	No	Yes	No	Yes	No	No	Yes	No	No	No	No	Yes
50th-Percentile Queue Length [veh/ln]	4.27	11.76	2.64	0.25	5.21	3.70	1.66	3.10	2.24	18.70	10.53	11.23
50th-Percentile Queue Length [ft/ln]	106.76	293.94	66.10	6.14	130.30	92.57	41.52	77.40	56.00	467.50	263.15	280.81
95th-Percentile Queue Length [veh/ln]	7.66	17.38	4.76	0.44	8.96	6.66	2.99	5.57	4.03	29.56	15.85	16.73
95th-Percentile Queue Length [ft/ln]	191.48	434.52	118.99	11.05	223.91	166.62	74.73	139.31	100.80	738.90	396.17	418.22



**Movement, Approach, & Intersection Results**

d_M, Delay for Movement [s/veh]	69.95	57.79	48.61	75.56	59.95	59.58	75.09	17.08	17.04	290.86	17.23	17.79
Movement LOS	E	E	D	E	E	E	E	B	B	F	B	B
d_A, Approach Delay [s/veh]	59.98			60.22			22.64			84.80		
Approach LOS	E			E			C			F		
d_I, Intersection Delay [s/veh]	64.82											
Intersection LOS	E											
Intersection V/C	0.569											

**Emissions**

Vehicle Miles Traveled [mph]	33.79	65.25	17.05	1.40	50.98	12.11	9.60	61.04	29.38	488.90	980.87	510.46
Stops [stops/h]	307.37	564.21	126.88	11.78	375.17	88.84	79.69	222.84	107.49	897.36	505.10	269.50
Fuel consumption [US gal/h]	8.34	14.29	3.27	0.33	10.11	2.39	2.41	6.23	3.00	59.23	43.95	23.03
CO [g/h]	582.92	999.00	228.27	22.81	706.53	167.08	168.47	435.58	209.65	4140.21	3071.79	1610.11
NOx [g/h]	113.42	194.37	44.41	4.44	137.46	32.51	32.78	84.75	40.79	805.54	597.66	313.27
VOC [g/h]	135.10	231.53	52.90	5.29	163.74	38.72	39.04	100.95	48.59	959.53	711.92	373.16

**Other Modes**

g_Walk,mi, Effective Walk Time [s]	8.0			8.0			8.0			8.0		
M_corner, Corner Circulation Area [ft <sup>2</sup> /ped]	0.00			0.00			0.00			0.00		
M_CW, Crosswalk Circulation Area [ft <sup>2</sup> /ped]	2837.06			892.38			816.78			3179.53		
d_p, Pedestrian Delay [s]	67.23			67.23			67.23			67.23		
I_p,int, Pedestrian LOS Score for Intersectio	3.265			2.940			3.378			3.233		
Crosswalk LOS	C			C			C			C		
s_b, Saturation Flow Rate of the bicycle lane	2000			2000			2000			2000		
c_b, Capacity of the bicycle lane [bicycles/h]	653			605			733			800		
d_b, Bicycle Delay [s]	34.02			36.49			30.10			27.03		
I_b,int, Bicycle LOS Score for Intersection	2.503			1.864			2.041			2.798		
Bicycle LOS	B			A			B			C		

**Sequence**

Ring 1	1	2	3	4	-	-	-	-	-	-	-	-	-	-	-
Ring 2	5	6	7	8	-	-	-	-	-	-	-	-	-	-	-
Ring 3	-	-	-	-	-	-	-	-	-	-	-	-	-	-	-
Ring 4	-	-	-	-	-	-	-	-	-	-	-	-	-	-	-

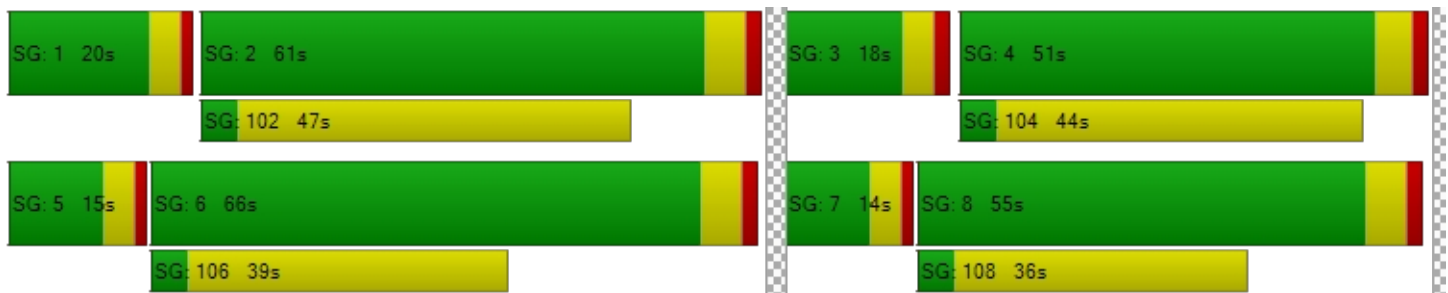

**Intersection Level Of Service Report**  
**Intersection 2: Tassajara Road & Central Parkway**

Control Type:	Signalized	Delay (sec / veh):	29.3
Analysis Method:	HCM 7th Edition	Level Of Service:	C
Analysis Period:	15 minutes	Volume to Capacity (v/c):	0.640

**Intersection Setup**

Name	Tassajara Road			Tassajara Road			Central Parkway			Central Parkway		
Approach	Northbound			Southbound			Eastbound			Westbound		
Lane Configuration	⇐   ⇐			⇐   ⇐			⇐  ⇐			⇐  ⇐		
Turning Movement	Left	Thru	Right	Left	Thru	Right	Left	Thru	Right	Left	Thru	Right
Lane Width [ft]	12.00	12.00	12.00	12.00	12.00	12.00	12.00	12.00	12.00	12.00	12.00	12.00
No. of Lanes in Entry Pocket	1	0	1	1	0	1	1	0	1	2	0	0
Entry Pocket Length [ft]	325.00	100.00	325.00	300.00	100.00	215.00	225.00	100.00	225.00	300.00	100.00	100.00
No. of Lanes in Exit Pocket	0	0	0	0	0	0	0	0	0	0	0	0
Exit Pocket Length [ft]	0.00	0.00	0.00	0.00	0.00	0.00	0.00	0.00	0.00	0.00	0.00	0.00
Speed [mph]	40.00			40.00			35.00			35.00		
Grade [%]	0.00			0.00			0.00			0.00		
Curb Present	Yes			Yes			Yes			Yes		
Crosswalk	Yes			Yes			Yes			Yes		



**Volumes**

Name	Tassajara Road			Tassajara Road			Central Parkway			Central Parkway		
Base Volume Input [veh/h]	38	649	106	19	1341	132	91	111	60	215	136	19
Base Volume Adjustment Factor	1.0000	1.0000	1.0000	1.0000	1.0000	1.0000	1.0000	1.0000	1.0000	1.0000	1.0000	1.0000
Heavy Vehicles Percentage [%]	0.00	2.00	8.50	0.00	0.70	2.10	1.10	0.00	1.70	0.90	0.00	0.00
Proportion of CAVs [%]	0.00											
Growth Factor	1.0000	1.0000	1.0000	1.0000	1.0000	1.0000	1.0000	1.0000	1.0000	1.0000	1.0000	1.0000
In-Process Volume [veh/h]	0	0	0	0	0	0	0	0	0	0	0	0
Site-Generated Trips [veh/h]	0	0	0	0	0	0	0	0	0	0	0	0
Diverted Trips [veh/h]	0	0	0	0	0	0	0	0	0	0	0	0
Pass-by Trips [veh/h]	0	0	0	0	0	0	0	0	0	0	0	0
Existing Site Adjustment Volume [veh/h]	0	0	0	0	0	0	0	0	0	0	0	0
Other Volume [veh/h]	0	0	0	0	0	0	0	0	0	0	0	0
Right Turn on Red Volume [veh/h]	0	0	0	0	0	0	0	0	0	0	0	0
Total Hourly Volume [veh/h]	38	649	106	19	1341	132	91	111	60	215	136	19
Peak Hour Factor	0.9100	0.9100	0.9100	0.9100	0.9100	0.9100	0.9100	0.9100	0.9100	0.9100	0.9100	0.9100
Other Adjustment Factor	1.0000	1.0000	1.0000	1.0000	1.0000	1.0000	1.0000	1.0000	1.0000	1.0000	1.0000	1.0000
Total 15-Minute Volume [veh/h]	10	178	29	5	368	36	25	30	16	59	37	5
Total Analysis Volume [veh/h]	42	713	116	21	1474	145	100	122	66	236	149	21
Presence of On-Street Parking	No		No	No		No	No		No	No		No
On-Street Parking Maneuver Rate [/h]	0	0	0	0	0	0	0	0	0	0	0	0
Local Bus Stopping Rate [/h]	0	0	0	0	0	0	0	0	0	0	0	0
v_do, Outbound Pedestrian Volume crossing	2			2			1			2		
v_di, Inbound Pedestrian Volume crossing m	1			2			2			2		
v_co, Outbound Pedestrian Volume crossing	1			6			7			2		
v_ci, Inbound Pedestrian Volume crossing mi	2			7			6			1		
v_ab, Corner Pedestrian Volume [ped/h]	0			0			0			0		
Bicycle Volume [bicycles/h]	0			0			0			12		



**Intersection Settings**

Located in CBD	No
Signal Coordination Group	-
Cycle Length [s]	130
Active Pattern	Pattern 1
Coordination Type	Time of Day Pattern Coordinated
Actuation Type	Fully actuated
Offset [s]	20.0
Offset Reference	Lead Green - Beginning of First Green
Permissive Mode	SingleBand
Lost time [s]	12.00

**Phasing & Timing (Basic)**

Control Type	Protecte	Permiss	Permiss	Protecte	Permiss	Permiss	Protecte	Permiss	Permiss	Protecte	Permiss	Permiss
Signal Group	3	8	0	7	4	0	5	2	0	1	6	0
Auxiliary Signal Groups												
Maximum Green [s]	20	40	0	20	40	0	20	20	0	20	20	0
Amber [s]	3.5	4.3	0.0	3.5	4.3	0.0	3.5	4.1	0.0	3.5	4.1	0.0
All red [s]	1.0	1.0	0.0	1.0	1.0	0.0	1.0	1.0	0.0	1.0	1.0	0.0
Walk [s]	0	4	0	0	4	0	0	4	0	0	4	0
Pedestrian Clearance [s]	0	20	0	0	24	0	0	36	0	0	30	0
Delayed Vehicle Green [s]	0.0	0.0	0.0	0.0	0.0	0.0	0.0	0.0	0.0	0.0	0.0	0.0
Rest In Walk		No			No			No			No	
I1, Start-Up Lost Time [s]	2.0	2.0	0.0	2.0	2.0	0.0	2.0	2.0	0.0	2.0	2.0	0.0
I2, Clearance Lost Time [s]	2.5	3.3	0.0	2.5	3.3	0.0	2.5	3.1	0.0	2.5	3.1	0.0
Detector Location [ft]	0.0	0.0	0.0	0.0	0.0	0.0	0.0	0.0	0.0	0.0	0.0	0.0
Detector Length [ft]	20.0	20.0	0.0	20.0	20.0	0.0	20.0	20.0	0.0	20.0	20.0	0.0
I, Upstream Filtering Factor	1.00	1.00	1.00	1.00	1.00	1.00	1.00	1.00	1.00	1.00	1.00	1.00

**Phasing & Timing: Pattern 1**

Split [s]	18	48	0	18	48	0	23	45	0	19	41	0
Lead / Lag	Lead	-	-	Lead	-	-	Lead	-	-	Lead	-	-
Minimum Green [s]	13	12	0	13	12	0	13	13	0	14	13	0
Vehicle Extension [s]	2.5	4.0	0.0	2.5	4.0	0.0	2.5	2.5	0.0	2.5	2.5	0.0
Minimum Recall	No	Yes		No	Yes		No	No		No	No	
Maximum Recall	No	No		No	No		No	No		No	No	
Pedestrian Recall	No	No		No	No		No	No		No	No	

**Exclusive Pedestrian Phase**

Pedestrian Signal Group	0
Pedestrian Walk [s]	0
Pedestrian Clearance [s]	0



**Lane Group Calculations**

Lane Group	L	C	R	L	C	R	L	C	R	L	C
C, Cycle Length [s]	130	130	130	130	130	130	130	130	130	130	130
L, Total Lost Time per Cycle [s]	4.50	5.30	5.30	4.50	5.30	5.30	4.50	5.10	5.10	4.50	5.10
l1_p, Permitted Start-Up Lost Time [s]	0.00	0.00	0.00	0.00	0.00	0.00	0.00	0.00	0.00	0.00	0.00
l2, Clearance Lost Time [s]	2.50	3.30	3.30	2.50	3.30	3.30	2.50	3.10	3.10	2.50	3.10
g_i, Effective Green Time [s]	10	75	75	7	72	72	13	14	14	14	16
g / C, Green / Cycle	0.08	0.58	0.58	0.05	0.55	0.55	0.10	0.11	0.11	0.11	0.12
(v / s)_i Volume / Saturation Flow Rate	0.02	0.20	0.08	0.01	0.41	0.09	0.06	0.06	0.04	0.07	0.09
s, saturation flow rate [veh/h]	1810	3560	1503	1810	3598	1570	1794	1900	1580	3489	1848
c, Capacity [veh/h]	142	2058	869	97	1991	868	175	211	176	376	225
d1, Uniform Delay [s]	56.51	14.46	12.53	58.90	21.97	14.27	56.05	54.85	53.55	55.47	55.22
k, delay calibration	0.08	0.50	0.50	0.08	0.50	0.50	0.08	0.08	0.08	0.08	0.08
l, Upstream Filtering Factor	1.00	1.00	1.00	1.00	1.00	1.00	1.00	1.00	1.00	1.00	1.00
d2, Incremental Delay [s]	0.86	0.46	0.32	0.82	2.53	0.41	2.18	1.85	0.98	1.28	3.86
d3, Initial Queue Delay [s]	0.00	0.00	0.00	0.00	0.00	0.00	0.00	0.00	0.00	0.00	0.00
Rp, platoon ratio	1.00	1.00	1.00	1.00	1.00	1.00	1.00	1.00	1.00	1.00	1.00
PF, progression factor	1.00	1.00	1.00	1.00	1.00	1.00	1.00	1.00	1.00	1.00	1.00

**Lane Group Results**

X, volume / capacity	0.30	0.35	0.13	0.22	0.74	0.17	0.57	0.58	0.38	0.63	0.76
d, Delay for Lane Group [s/veh]	57.37	14.92	12.85	59.72	24.49	14.68	58.22	56.70	54.53	56.75	59.08
Lane Group LOS	E	B	B	E	C	B	E	E	D	E	E
Critical Lane Group	Yes	No	No	No	Yes	No	Yes	No	No	No	Yes
50th-Percentile Queue Length [veh/ln]	1.32	5.43	1.57	0.68	16.65	2.14	3.23	3.89	2.04	3.75	5.60
50th-Percentile Queue Length [ft/ln]	33.03	135.70	39.25	16.94	416.31	53.48	80.69	97.17	51.09	93.75	139.92
95th-Percentile Queue Length [veh/ln]	2.38	9.25	2.83	1.22	23.34	3.85	5.81	7.00	3.68	6.75	9.48
95th-Percentile Queue Length [ft/ln]	59.46	231.23	70.65	30.49	583.61	96.26	145.24	174.91	91.96	168.76	236.92





**Movement, Approach, & Intersection Results**

d_M, Delay for Movement [s/veh]	57.37	14.92	12.85	59.72	24.49	14.68	58.22	56.70	54.53	56.75	59.08	59.08
Movement LOS	E	B	B	E	C	B	E	E	D	E	E	E
d_A, Approach Delay [s/veh]	16.69			24.08			56.73			57.72		
Approach LOS	B			C			E			E		
d_I, Intersection Delay [s/veh]	29.27											
Intersection LOS	C											
Intersection V/C	0.640											

**Emissions**

Vehicle Miles Traveled [mph]	12.11	205.62	33.45	3.99	280.39	27.58	13.16	16.06	8.69	32.00	23.05
Stops [stops/h]	36.59	300.69	43.49	18.76	922.42	59.24	89.39	107.65	56.60	207.73	155.02
Fuel consumption [US gal/h]	1.28	12.48	1.93	0.58	26.45	2.00	2.36	2.83	1.49	5.51	4.09
CO [g/h]	89.73	872.68	134.82	40.72	1848.98	140.03	164.87	197.75	104.08	384.94	285.76
NOx [g/h]	17.46	169.79	26.23	7.92	359.74	27.25	32.08	38.47	20.25	74.90	55.60
VOC [g/h]	20.79	202.25	31.25	9.44	428.52	32.45	38.21	45.83	24.12	89.21	66.23

**Other Modes**

g_Walk,mi, Effective Walk Time [s]	8.0			8.0			8.0			8.0		
M_corner, Corner Circulation Area [ft <sup>2</sup> /ped]	0.00			0.00			0.00			0.00		
M_CW, Crosswalk Circulation Area [ft <sup>2</sup> /ped]	1666.25			1344.85			226.05			1047.71		
d_p, Pedestrian Delay [s]	57.24			57.24			57.24			57.24		
I_p,int, Pedestrian LOS Score for Intersectio	3.175			3.009			2.328			2.340		
Crosswalk LOS	C			C			B			B		
s_b, Saturation Flow Rate of the bicycle lane	2000			2000			2000			2000		
c_b, Capacity of the bicycle lane [bicycles/h]	657			657			614			552		
d_b, Bicycle Delay [s]	29.30			29.30			31.21			34.25		
I_b,int, Bicycle LOS Score for Intersection	2.278			2.913			2.035			2.230		
Bicycle LOS	B			C			B			B		

**Sequence**

Ring 1	1	2	3	4	-	-	-	-	-	-	-	-	-	-	-
Ring 2	5	6	7	8	-	-	-	-	-	-	-	-	-	-	-
Ring 3	-	-	-	-	-	-	-	-	-	-	-	-	-	-	-
Ring 4	-	-	-	-	-	-	-	-	-	-	-	-	-	-	-

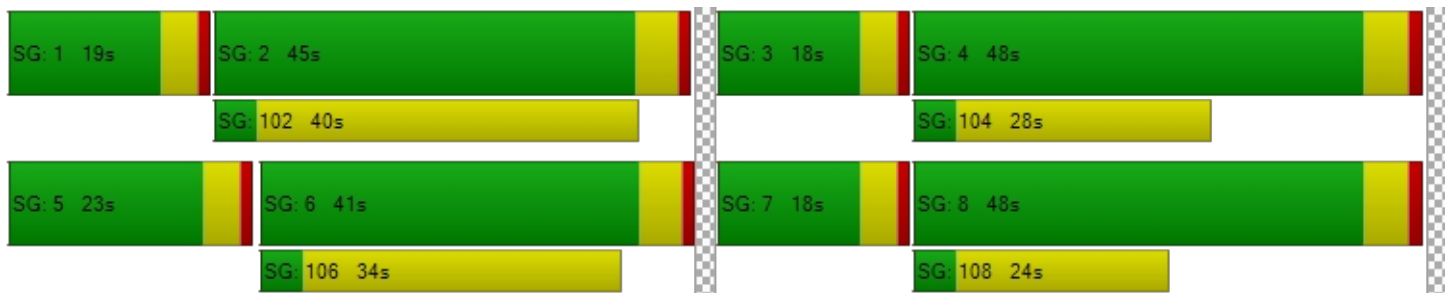

**Intersection Level Of Service Report**  
**Intersection 3: Tassajara Road & Dublin Boulevard**

Control Type:	Signalized	Delay (sec / veh):	178.7
Analysis Method:	HCM 7th Edition	Level Of Service:	F
Analysis Period:	15 minutes	Volume to Capacity (v/c):	1.192

**Intersection Setup**

Name	Tassajara Road			Tassajara Road			Dublin Boulevard			Dublin Boulevard		
Approach	Northbound			Southbound			Eastbound			Westbound		
Lane Configuration	[Diagram]			[Diagram]			[Diagram]			[Diagram]		
Turning Movement	Left	Thru	Right	Left	Thru	Right	Left	Thru	Right	Left	Thru	Right
Lane Width [ft]	12.00	12.00	12.00	12.00	12.00	12.00	12.00	12.00	12.00	12.00	12.00	12.00
No. of Lanes in Entry Pocket	3	0	1	2	0	2	2	0	2	3	0	0
Entry Pocket Length [ft]	380.00	100.00	250.00	295.00	100.00	290.00	265.00	100.00	330.00	395.00	100.00	100.00
No. of Lanes in Exit Pocket	0	0	1	0	0	0	0	0	0	0	0	0
Exit Pocket Length [ft]	0.00	0.00	49.21	0.00	0.00	0.00	0.00	0.00	0.00	0.00	0.00	0.00
Speed [mph]	30.00			40.00			40.00			40.00		
Grade [%]	0.00			0.00			0.00			0.00		
Curb Present	Yes			Yes			Yes			Yes		
Crosswalk	Yes			Yes			Yes			Yes		



**Volumes**

Name	Tassajara Road			Tassajara Road			Dublin Boulevard			Dublin Boulevard		
Base Volume Input [veh/h]	350	631	674	86	1338	154	102	274	148	575	1706	142
Base Volume Adjustment Factor	1.0000	1.0000	1.0000	1.0000	1.0000	1.0000	1.0000	1.0000	1.0000	1.0000	1.0000	1.0000
Heavy Vehicles Percentage [%]	3.30	2.90	1.00	0.00	0.70	3.30	2.00	3.70	4.70	1.60	2.00	0.00
Proportion of CAVs [%]	0.00											
Growth Factor	1.0000	1.0000	1.0000	1.0000	1.0000	1.0000	1.0000	1.0000	1.0000	1.0000	1.0000	1.0000
In-Process Volume [veh/h]	0	0	0	0	0	0	0	0	0	0	0	0
Site-Generated Trips [veh/h]	0	0	0	0	0	0	0	0	0	0	0	0
Diverted Trips [veh/h]	0	0	0	0	0	0	0	0	0	0	0	0
Pass-by Trips [veh/h]	0	0	0	0	0	0	0	0	0	0	0	0
Existing Site Adjustment Volume [veh/h]	0	0	0	0	0	0	0	0	0	0	0	0
Other Volume [veh/h]	0	0	0	0	0	0	0	0	0	0	0	0
Right Turn on Red Volume [veh/h]	0	0	0	0	0	0	0	0	0	0	0	0
Total Hourly Volume [veh/h]	350	631	674	86	1338	154	102	274	148	575	1706	142
Peak Hour Factor	0.9200	0.9200	0.9200	0.9200	0.9200	0.9200	0.9200	0.9200	0.9200	0.9200	0.9200	0.9200
Other Adjustment Factor	1.0000	1.0000	1.0000	1.0000	1.0000	1.0000	1.0000	1.0000	1.0000	1.0000	1.0000	1.0000
Total 15-Minute Volume [veh/h]	95	171	183	23	364	42	28	74	40	156	464	39
Total Analysis Volume [veh/h]	380	686	733	93	1454	167	111	298	161	625	1854	154
Presence of On-Street Parking	No		No	No		No	No		No	No		No
On-Street Parking Maneuver Rate [/h]	0	0	0	0	0	0	0	0	0	0	0	0
Local Bus Stopping Rate [/h]	0	0	0	0	0	0	0	0	0	0	0	0
v_do, Outbound Pedestrian Volume crossing	1			2			2			1		
v_di, Inbound Pedestrian Volume crossing m	1			2			2			1		
v_co, Outbound Pedestrian Volume crossing	0			4			0			3		
v_ci, Inbound Pedestrian Volume crossing mi	0			3			0			4		
v_ab, Corner Pedestrian Volume [ped/h]	0			0			0			0		
Bicycle Volume [bicycles/h]	1			0			0			0		

**Intersection Settings**

Located in CBD	No
Signal Coordination Group	-
Cycle Length [s]	90
Active Pattern	Free Running (No Pattern)
Coordination Type	<i>Free Running</i>
Actuation Type	<i>Fully actuated</i>
Offset [s]	0.0
Offset Reference	Lead Green - Beginning of First Green
Permissive Mode	SingleBand
Lost time [s]	12.00

**Phasing & Timing (Basic)**

Control Type	Protecte	Permiss	Permiss	Protecte	Permiss	Permiss	Protecte	Permiss	Overlap	Protecte	Permiss	Permiss
Signal Group	3	8	0	7	4	0	5	2	2	1	6	0
Auxiliary Signal Groups									2,3			
Maximum Green [s]	20	35	0	20	35	0	20	35	35	20	35	0
Amber [s]	3.5	4.5	0.0	3.5	4.5	0.0	3.5	4.5	4.5	3.5	4.5	0.0
All red [s]	1.5	1.5	0.0	1.5	1.5	0.0	1.5	1.5	1.5	1.5	1.5	0.0
Walk [s]	0	4	0	0	4	0	0	0	0	0	4	0
Pedestrian Clearance [s]	0	29	0	0	42	0	0	0	0	0	42	0
Delayed Vehicle Green [s]	0.0	0.0	0.0	0.0	0.0	0.0	0.0	0.0	0.0	0.0	0.0	0.0
Rest In Walk		No			No			No			No	
I1, Start-Up Lost Time [s]	2.0	2.0	0.0	2.0	2.0	0.0	2.0	2.0	2.0	2.0	2.0	0.0
I2, Clearance Lost Time [s]	2.0	2.0	0.0	2.0	2.0	0.0	2.0	2.0	2.0	2.0	2.0	0.0
Detector Location [ft]	0.0	0.0	0.0	0.0	0.0	0.0	0.0	0.0	0.0	0.0	0.0	0.0
Detector Length [ft]	20.0	20.0	0.0	20.0	20.0	0.0	20.0	20.0	20.0	20.0	20.0	0.0
I, Upstream Filtering Factor	1.00	1.00	1.00	1.00	1.00	1.00	1.00	1.00	1.00	1.00	1.00	1.00

**Phasing & Timing: Free Running (No Pattern)**

Split [s]	0	0	0	0	0	0	0	0	0	0	0	0
Lead / Lag	Lead	-	-	Lead	-	-	Lead	-	-	Lead	-	-
Minimum Green [s]	16	15	0	15	15	0	16	16	16	16	15	0
Vehicle Extension [s]	2.0	4.0	0.0	2.0	4.0	0.0	2.0	3.0	3.0	2.0	3.0	0.0
Minimum Recall	No	Yes		No	Yes		No	No	No	No	No	
Maximum Recall	No	No		No	No		No	No	No	No	No	
Pedestrian Recall	No	No		No	No		No	No	No	No	No	

**Exclusive Pedestrian Phase**

Pedestrian Signal Group	0
Pedestrian Walk [s]	0
Pedestrian Clearance [s]	0



**Lane Group Calculations**

Lane Group	L	C	R	L	C	R	L	C	R	L	C	C
C, Cycle Length [s]	122	122	122	122	122	122	122	122	122	122	122	122
L, Total Lost Time per Cycle [s]	4.00	4.00	4.00	4.00	4.00	4.00	4.00	4.00	4.00	4.00	4.00	4.00
l1_p, Permitted Start-Up Lost Time [s]	0.00	0.00	0.00	0.00	0.00	0.00	0.00	0.00	0.00	0.00	0.00	0.00
l2, Clearance Lost Time [s]	2.00	2.00	2.00	2.00	2.00	2.00	2.00	2.00	0.00	2.00	2.00	2.00
g_i, Effective Green Time [s]	17	37	37	15	36	36	17	36	57	18	37	37
g / C, Green / Cycle	0.14	0.30	0.30	0.13	0.29	0.29	0.14	0.29	0.46	0.15	0.30	0.30
(v / s)_i Volume / Saturation Flow Rate	0.07	0.19	0.46	0.03	0.21	0.06	0.03	0.08	0.06	0.12	0.54	0.55
s, saturation flow rate [veh/h]	5134	3535	1579	3514	6863	2773	3459	3512	2752	5205	1870	1818
c, Capacity [veh/h]	715	1077	481	444	2003	809	472	1024	1253	764	565	549
d1, Uniform Delay [s]	49.02	36.74	42.32	48.04	38.99	32.69	47.21	33.60	19.31	50.68	42.77	42.77
k, delay calibration	0.04	0.15	0.50	0.04	0.15	0.15	0.04	0.11	0.11	0.04	0.50	0.50
l, Upstream Filtering Factor	1.00	1.00	1.00	1.00	1.00	1.00	1.00	1.00	1.00	1.00	1.00	1.00
d2, Incremental Delay [s]	0.23	0.90	245.92	0.09	0.73	0.18	0.09	0.16	0.05	0.84	357.25	379.88
d3, Initial Queue Delay [s]	0.00	0.00	0.00	0.00	0.00	0.00	0.00	0.00	0.00	0.00	0.00	0.00
Rp, platoon ratio	1.00	1.00	1.00	1.00	1.00	1.00	1.00	1.00	1.00	1.00	1.00	1.00
PF, progression factor	1.00	1.00	1.00	1.00	1.00	1.00	1.00	1.00	1.00	1.00	1.00	1.00

**Lane Group Results**

X, volume / capacity	0.53	0.64	1.52	0.21	0.73	0.21	0.24	0.29	0.13	0.82	1.78	1.83
d, Delay for Lane Group [s/veh]	49.25	37.64	288.24	48.13	39.72	32.87	47.30	33.76	19.36	51.52	400.02	422.65
Lane Group LOS	D	D	F	D	D	C	D	C	B	D	F	F
Critical Lane Group	No	No	Yes	Yes	No	No	Yes	No	No	No	No	Yes
50th-Percentile Queue Length [veh/ln]	3.62	8.97	47.14	1.27	9.67	1.86	1.50	3.40	1.31	6.14	72.53	73.98
50th-Percentile Queue Length [ft/ln]	90.62	224.16	1178.56	31.64	241.76	46.57	37.47	84.96	32.63	153.52	1813.22	1849.56
95th-Percentile Queue Length [veh/ln]	6.52	13.88	72.37	2.28	14.77	3.35	2.70	6.12	2.35	10.20	112.55	115.34
95th-Percentile Queue Length [ft/ln]	163.12	346.93	1809.20	56.95	369.26	83.83	67.45	152.93	58.74	255.12	2813.70	2883.60



**Movement, Approach, & Intersection Results**

d_M, Delay for Movement [s/veh]	49.25	37.64	288.24	48.13	39.72	32.87	47.30	33.76	19.36	51.52	410.40	422.65
Movement LOS	D	D	F	D	D	C	D	C	B	D	F	F
d_A, Approach Delay [s/veh]	142.20			39.51			32.33			325.92		
Approach LOS	F			D			C			F		
d_I, Intersection Delay [s/veh]	178.69											
Intersection LOS	F											
Intersection V/C	1.192											

**Emissions**

Vehicle Miles Traveled [mph]	77.95	140.72	150.36	26.82	419.31	48.16	97.60	262.04	141.57	751.97	1207.97	1207.97
Stops [stops/h]	319.81	527.39	1386.40	74.43	1137.57	109.57	88.17	199.89	76.77	541.77	2132.98	2175.72
Fuel consumption [US gal/h]	8.78	13.96	56.84	2.60	37.95	3.92	5.43	13.40	6.46	38.81	145.93	150.98
CO [g/h]	613.99	975.84	3972.80	181.92	2652.42	273.90	379.61	936.46	451.52	2712.81	10200.8	10553.2
NOx [g/h]	119.46	189.86	772.96	35.40	516.07	53.29	73.86	182.20	87.85	527.81	1984.71	2053.28
VOC [g/h]	142.30	226.16	920.73	42.16	614.72	63.48	87.98	217.03	104.64	628.72	2364.14	2445.82

**Other Modes**

g_Walk,mi, Effective Walk Time [s]	-6.0		8.0		8.0		8.0	
M_corner, Corner Circulation Area [ft <sup>2</sup> /ped]	0.00		0.00		0.00		0.00	
M_CW, Crosswalk Circulation Area [ft <sup>2</sup> /ped]	0.00		0.00		0.00		0.00	
d_p, Pedestrian Delay [s]	67.35		53.47		53.47		53.47	
I_p,int, Pedestrian LOS Score for Intersectio	3.386		3.330		3.295		3.353	
Crosswalk LOS	C		C		C		C	
s_b, Saturation Flow Rate of the bicycle lane	2000		2000		2000		2000	
c_b, Capacity of the bicycle lane [bicycles/h]	572		572		572		572	
d_b, Bicycle Delay [s]	31.23		31.21		31.21		31.21	
I_b,int, Bicycle LOS Score for Intersection	3.044		2.267		2.030		3.732	
Bicycle LOS	C		B		B		D	

**Sequence**

Ring 1	1	2	3	4	-	-	-	-	-	-	-	-	-	-	-
Ring 2	5	6	7	8	-	-	-	-	-	-	-	-	-	-	-
Ring 3	-	-	-	-	-	-	-	-	-	-	-	-	-	-	-
Ring 4	-	-	-	-	-	-	-	-	-	-	-	-	-	-	-



**Intersection Level Of Service Report**  
**Intersection 4: Tassajara Road & I-580 WB Ramps**

Control Type:	Signalized	Delay (sec / veh):	15.2
Analysis Method:	HCM 7th Edition	Level Of Service:	B
Analysis Period:	15 minutes	Volume to Capacity (v/c):	0.764

**Intersection Setup**

Name	Tassajara Road		Tassajara Road		I-580 WB Ramps	
Approach	Northbound		Southbound		Westbound	
Lane Configuration	↑↑		↑↑↑		↔↔↔↔	
Turning Movement	Thru	Right	Left	Thru	Left	Right
Lane Width [ft]	12.00	12.00	12.00	12.00	12.00	12.00
No. of Lanes in Entry Pocket	0	0	0	0	1	1
Entry Pocket Length [ft]	100.00	100.00	100.00	100.00	100.00	100.00
No. of Lanes in Exit Pocket	0	1	0	0	0	0
Exit Pocket Length [ft]	0.00	49.21	0.00	0.00	0.00	0.00
Speed [mph]	30.00		30.00		30.00	
Grade [%]	0.00		0.00		0.00	
Curb Present	No		No		No	
Crosswalk	Yes		Yes		Yes	



**Volumes**

Name	Tassajara Road		Tassajara Road		I-580 WB Ramps	
Base Volume Input [veh/h]	1764	0	0	949	631	365
Base Volume Adjustment Factor	1.0000	1.0000	1.0000	1.0000	1.0000	1.0000
Heavy Vehicles Percentage [%]	2.30	2.00	2.00	1.80	2.90	4.00
Proportion of CAVs [%]	0.00					
Growth Factor	1.0000	1.0000	1.0000	1.0000	1.0000	1.0000
In-Process Volume [veh/h]	0	0	0	0	0	0
Site-Generated Trips [veh/h]	0	0	0	0	0	0
Diverted Trips [veh/h]	0	0	0	0	0	0
Pass-by Trips [veh/h]	0	0	0	0	0	0
Existing Site Adjustment Volume [veh/h]	0	0	0	0	0	0
Other Volume [veh/h]	0	0	0	0	0	0
Right Turn on Red Volume [veh/h]	0	0	0	0	0	0
Total Hourly Volume [veh/h]	1764	0	0	949	631	365
Peak Hour Factor	0.9800	1.0000	1.0000	0.9800	0.9800	0.9800
Other Adjustment Factor	1.0000	1.0000	1.0000	1.0000	1.0000	1.0000
Total 15-Minute Volume [veh/h]	450	0	0	242	161	93
Total Analysis Volume [veh/h]	1800	0	0	968	644	372
Presence of On-Street Parking	No	No	No	No	No	No
On-Street Parking Maneuver Rate [/h]	0	0	0	0	0	0
Local Bus Stopping Rate [/h]	0	0	0	0	0	0
v_do, Outbound Pedestrian Volume crossing	0		0		0	
v_di, Inbound Pedestrian Volume crossing m	0		0		0	
v_co, Outbound Pedestrian Volume crossing	0		0		0	
v_ci, Inbound Pedestrian Volume crossing mi	0		0		0	
v_ab, Corner Pedestrian Volume [ped/h]	0		0		0	
Bicycle Volume [bicycles/h]	0		0		0	





**Intersection Settings**

Located in CBD	No
Signal Coordination Group	-
Cycle Length [s]	60
Active Pattern	Pattern 1
Coordination Type	Time of Day Pattern Coordinated
Actuation Type	Fully actuated
Offset [s]	20.0
Offset Reference	Beginning of First Yellow
Permissive Mode	SingleBand
Lost time [s]	6.00

**Phasing & Timing (Basic)**

Control Type	Permissive	Permissive	Permissive	Permissive	Split	Split
Signal Group	6	0	0	2	4	0
Auxiliary Signal Groups						
Maximum Green [s]	40	0	0	40	20	0
Amber [s]	4.9	0.0	0.0	4.9	4.4	0.0
All red [s]	1.0	0.0	0.0	1.0	1.0	0.0
Walk [s]	5	0	0	0	0	0
Pedestrian Clearance [s]	16	0	0	0	0	0
Delayed Vehicle Green [s]	0.0	0.0	0.0	0.0	0.0	0.0
Rest In Walk	No			No	No	
I1, Start-Up Lost Time [s]	2.0	0.0	0.0	2.0	2.0	0.0
I2, Clearance Lost Time [s]	3.9	0.0	0.0	3.9	3.4	0.0
Detector Location [ft]	0.0	0.0	0.0	0.0	0.0	0.0
Detector Length [ft]	20.0	0.0	0.0	20.0	20.0	0.0
I, Upstream Filtering Factor	1.00	1.00	1.00	1.00	1.00	1.00

**Phasing & Timing: Pattern 1**

Split [s]	38	0	0	38	22	0
Lead / Lag	-	-	-	-	Lead	-
Minimum Green [s]	7	0	0	7	4	0
Vehicle Extension [s]	3.0	0.0	0.0	3.0	2.0	0.0
Minimum Recall	No			No	No	
Maximum Recall	Yes			Yes	No	
Pedestrian Recall	Yes			No	No	

**Exclusive Pedestrian Phase**

Pedestrian Signal Group	0
Pedestrian Walk [s]	0
Pedestrian Clearance [s]	0



**Lane Group Calculations**

Lane Group	C	C	L	R
C, Cycle Length [s]	66	66	66	66
L, Total Lost Time per Cycle [s]	5.90	5.90	5.40	5.40
l1_p, Permitted Start-Up Lost Time [s]	0.00	0.00	0.00	0.00
l2, Clearance Lost Time [s]	3.90	3.90	3.40	3.40
g_i, Effective Green Time [s]	40	40	15	15
g / C, Green / Cycle	0.61	0.61	0.22	0.22
(v / s)_i Volume / Saturation Flow Rate	0.51	0.19	0.19	0.13
s, saturation flow rate [veh/h]	3552	5102	3434	2768
c, Capacity [veh/h]	2151	3089	767	618
d1, Uniform Delay [s]	10.42	6.34	24.52	23.01
k, delay calibration	0.50	0.50	0.04	0.04
l, Upstream Filtering Factor	1.00	1.00	1.00	1.00
d2, Incremental Delay [s]	4.07	0.27	0.97	0.35
d3, Initial Queue Delay [s]	0.00	0.00	0.00	0.00
Rp, platoon ratio	1.00	1.00	1.00	1.00
PF, progression factor	1.00	1.00	1.00	1.00

**Lane Group Results**

X, volume / capacity	0.84	0.31	0.84	0.60
d, Delay for Lane Group [s/veh]	14.49	6.61	25.49	23.36
Lane Group LOS	B	A	C	C
Critical Lane Group	Yes	No	Yes	No
50th-Percentile Queue Length [veh/ln]	9.13	1.80	4.61	2.47
50th-Percentile Queue Length [ft/ln]	228.26	45.08	115.21	61.81
95th-Percentile Queue Length [veh/ln]	14.09	3.25	8.13	4.45
95th-Percentile Queue Length [ft/ln]	352.15	81.15	203.22	111.26

**Movement, Approach, & Intersection Results**

d_M, Delay for Movement [s/veh]	14.49	0.00	0.00	6.61	25.49	23.36
Movement LOS	B			A	C	C
d_A, Approach Delay [s/veh]	14.49		6.61		24.71	
Approach LOS	B		A		C	
d_I, Intersection Delay [s/veh]	15.22					
Intersection LOS	B					
Intersection V/C	0.764					

**Emissions**

Vehicle Miles Traveled [mph]	303.10	198.57	52.08	30.09
Stops [stops/h]	996.07	295.09	502.73	269.73
Fuel consumption [US gal/h]	23.29	11.11	8.26	4.50
CO [g/h]	1627.90	776.36	577.53	314.37
NOx [g/h]	316.73	151.05	112.37	61.17
VOC [g/h]	377.28	179.93	133.85	72.86

**Other Modes**

g_Walk,mi, Effective Walk Time [s]	16.6	16.6	9.0
M_corner, Corner Circulation Area [ft <sup>2</sup> /ped]	0.00	0.00	0.00
M_CW, Crosswalk Circulation Area [ft <sup>2</sup> /ped]	0.00	0.00	0.00
d_p, Pedestrian Delay [s]	18.49	18.49	24.61
I_p,int, Pedestrian LOS Score for Intersectio	2.939	2.886	2.484
Crosswalk LOS	C	C	B
s_b, Saturation Flow Rate of the bicycle lane	2000	2000	2000
c_b, Capacity of the bicycle lane [bicycles/h]	973	973	503
d_b, Bicycle Delay [s]	8.71	8.71	18.49
I_b,int, Bicycle LOS Score for Intersection	3.045	2.092	1.560
Bicycle LOS	C	B	A

**Sequence**

Ring 1	-	2	-	4	-	-	-	-	-	-	-	-	-	-	-	-
Ring 2	-	6	-	-	-	-	-	-	-	-	-	-	-	-	-	-
Ring 3	-	-	-	-	-	-	-	-	-	-	-	-	-	-	-	-
Ring 4	-	-	-	-	-	-	-	-	-	-	-	-	-	-	-	-



**Intersection Level Of Service Report**  
**Intersection 5: Santa Rita Rd & I-580 EB Ramps/Pimlico Dr**

Control Type:	Signalized	Delay (sec / veh):	36.4
Analysis Method:	HCM 7th Edition	Level Of Service:	D
Analysis Period:	15 minutes	Volume to Capacity (v/c):	0.814

**Intersection Setup**

Name	Santa Rita Road			Tassajara Road			I-580 EB Ramps			Pimlico Drive		
Approach	Northbound			Southbound			Eastbound			Westbound		
Lane Configuration	↑↑↑↑			↵↑↑			↵↑↑			↵↵↵↵		
Turning Movement	Left	Thru	Right	Left	Thru	Right	Left	Thru	Right	Left	Thru	Right
Lane Width [ft]	12.00	12.00	12.00	12.00	12.00	12.00	12.00	12.00	12.00	12.00	12.00	12.00
No. of Lanes in Entry Pocket	0	0	1	1	0	0	1	0	0	2	0	1
Entry Pocket Length [ft]	100.00	100.00	250.00	425.00	100.00	100.00	625.00	100.00	100.00	200.00	100.00	250.00
No. of Lanes in Exit Pocket	0	0	0	0	0	2	0	0	0	0	0	0
Exit Pocket Length [ft]	0.00	0.00	0.00	0.00	0.00	49.21	0.00	0.00	0.00	0.00	0.00	0.00
Speed [mph]	30.00			30.00			30.00			30.00		
Grade [%]	0.00			0.00			0.00			0.00		
Curb Present	No			No			No			No		
Crosswalk	Yes			No			Yes			Yes		



**Volumes**

Name	Santa Rita Road			Tassajara Road			I-580 EB Ramps			Pimlico Drive		
Base Volume Input [veh/h]	0	1123	84	164	1235	0	943	139	0	142	0	300
Base Volume Adjustment Factor	1.0000	1.0000	1.0000	1.0000	1.0000	1.0000	1.0000	1.0000	1.0000	1.0000	1.0000	1.0000
Heavy Vehicles Percentage [%]	2.00	3.30	2.40	1.80	2.30	2.00	2.10	2.40	2.00	0.70	2.00	2.40
Proportion of CAVs [%]	0.00											
Growth Factor	1.0000	1.0000	1.0000	1.0000	1.0000	1.0000	1.0000	1.0000	1.0000	1.0000	1.0000	1.0000
In-Process Volume [veh/h]	0	0	0	0	0	0	0	0	0	0	0	0
Site-Generated Trips [veh/h]	0	0	0	0	0	0	0	0	0	0	0	0
Diverted Trips [veh/h]	0	0	0	0	0	0	0	0	0	0	0	0
Pass-by Trips [veh/h]	0	0	0	0	0	0	0	0	0	0	0	0
Existing Site Adjustment Volume [veh/h]	0	0	0	0	0	0	0	0	0	0	0	0
Other Volume [veh/h]	0	0	0	0	0	0	0	0	0	0	0	0
Right Turn on Red Volume [veh/h]	0	0	0	0	0	0	0	0	0	0	0	0
Total Hourly Volume [veh/h]	0	1123	84	164	1235	0	943	139	0	142	0	300
Peak Hour Factor	1.0000	0.9600	0.9600	0.9600	0.9600	1.0000	0.9600	0.9600	1.0000	0.9600	1.0000	0.9600
Other Adjustment Factor	1.0000	1.0000	1.0000	1.0000	1.0000	1.0000	1.0000	1.0000	1.0000	1.0000	1.0000	1.0000
Total 15-Minute Volume [veh/h]	0	292	22	43	322	0	246	36	0	37	0	78
Total Analysis Volume [veh/h]	0	1170	88	171	1286	0	982	145	0	148	0	313
Presence of On-Street Parking	No		No	No		No	No		No	No		No
On-Street Parking Maneuver Rate [/h]	0	0	0	0	0	0	0	0	0	0	0	0
Local Bus Stopping Rate [/h]	0	0	0	0	0	0	0	0	0	0	0	0
v_do, Outbound Pedestrian Volume crossing	5			0			5			0		
v_di, Inbound Pedestrian Volume crossing m	5			0			5			0		
v_co, Outbound Pedestrian Volume crossing	0			2			2			1		
v_ci, Inbound Pedestrian Volume crossing mi	1			2			2			0		
v_ab, Corner Pedestrian Volume [ped/h]	0			0			0			0		
Bicycle Volume [bicycles/h]	0			0			0			0		



**Intersection Settings**

Located in CBD	No
Signal Coordination Group	-
Cycle Length [s]	120
Active Pattern	Pattern 1
Coordination Type	Time of Day Pattern Coordinated
Actuation Type	Fully actuated
Offset [s]	20.0
Offset Reference	Lead Green - Beginning of First Green
Permissive Mode	SingleBand
Lost time [s]	12.00

**Phasing & Timing (Basic)**

Control Type	Permiss	Permiss	Permiss	Protecte	Permiss	Permiss	Protecte	Permiss	Permiss	Permiss	Permiss	Overlap
Signal Group	0	6	0	5	2	0	3	8	0	7	0	4
Auxiliary Signal Groups												4,5
Maximum Green [s]	0	30	0	20	30	0	35	20	0	20	0	20
Amber [s]	0.0	4.4	0.0	3.0	4.4	0.0	4.4	4.4	0.0	3.5	0.0	3.5
All red [s]	0.0	1.0	0.0	1.0	1.0	0.0	1.0	1.0	0.0	1.0	0.0	1.0
Walk [s]	0	5	0	0	5	0	0	5	0	0	0	0
Pedestrian Clearance [s]	0	25	0	0	8	0	0	25	0	0	0	0
Delayed Vehicle Green [s]	0.0	0.0	0.0	0.0	0.0	0.0	0.0	0.0	0.0	0.0	0.0	0.0
Rest In Walk		No			No			No		No		
I1, Start-Up Lost Time [s]	0.0	2.0	0.0	2.0	2.0	0.0	2.0	2.0	0.0	2.0	0.0	2.0
I2, Clearance Lost Time [s]	0.0	3.4	0.0	2.0	3.4	0.0	3.4	3.4	0.0	2.5	0.0	2.5
Detector Location [ft]	0.0	0.0	0.0	0.0	0.0	0.0	0.0	0.0	0.0	0.0	0.0	0.0
Detector Length [ft]	0.0	20.0	0.0	20.0	20.0	0.0	20.0	20.0	0.0	20.0	0.0	0.0
I, Upstream Filtering Factor	1.00	1.00	1.00	1.00	1.00	1.00	1.00	1.00	1.00	1.00	1.00	1.00

**Phasing & Timing: Pattern 1**

Split [s]	0	41	0	25	66	0	40	36	0	18	0	14
Lead / Lag	-	-	-	Lead	-	-	Lead	-	-	Lead	-	-
Minimum Green [s]	0	7	0	5	7	0	5	5	0	5	0	5
Vehicle Extension [s]	0.0	3.0	0.0	3.0	3.0	0.0	3.0	2.0	0.0	3.0	0.0	2.0
Minimum Recall		No		No	No		No	No		No		No
Maximum Recall		Yes		No	Yes		No	No		No		No
Pedestrian Recall		No		No	Yes		No	No		No		No

**Exclusive Pedestrian Phase**

Pedestrian Signal Group	0
Pedestrian Walk [s]	0
Pedestrian Clearance [s]	0



**Lane Group Calculations**

Lane Group	C	C	L	C	L	C	L	R
C, Cycle Length [s]	120	120	120	120	120	120	120	120
L, Total Lost Time per Cycle [s]	5.40	5.40	4.00	5.40	5.40	5.40	4.50	4.00
l1_p, Permitted Start-Up Lost Time [s]	0.00	0.00	0.00	0.00	0.00	0.00	0.00	0.00
l2, Clearance Lost Time [s]	3.40	3.40	2.00	3.40	3.40	3.40	2.50	0.00
g_i, Effective Green Time [s]	46	46	14	64	35	33	7	24
g / C, Green / Cycle	0.39	0.39	0.12	0.54	0.29	0.28	0.06	0.20
(v / s)_i Volume / Saturation Flow Rate	0.23	0.18	0.10	0.36	0.28	0.08	0.04	0.11
s, saturation flow rate [veh/h]	4053	1763	1784	3552	3456	1864	3495	2804
c, Capacity [veh/h]	1565	681	206	1900	997	515	213	566
d1, Uniform Delay [s]	29.43	27.48	51.86	20.32	42.37	34.02	55.16	42.97
k, delay calibration	0.50	0.50	0.13	0.50	0.11	0.04	0.11	0.04
l, Upstream Filtering Factor	1.00	1.00	1.00	1.00	1.00	1.00	1.00	1.00
d2, Incremental Delay [s]	1.73	2.25	9.58	1.96	10.18	0.11	4.01	0.32
d3, Initial Queue Delay [s]	0.00	0.00	0.00	0.00	0.00	0.00	0.00	0.00
Rp, platoon ratio	1.00	1.00	1.00	1.00	1.00	1.00	1.00	1.00
PF, progression factor	1.00	1.00	1.00	1.00	1.00	1.00	1.00	1.00

**Lane Group Results**

X, volume / capacity	0.60	0.46	0.83	0.68	0.98	0.28	0.69	0.55
d, Delay for Lane Group [s/veh]	31.16	29.73	61.44	22.28	52.56	34.13	59.18	43.28
Lane Group LOS	C	C	E	C	D	C	E	D
Critical Lane Group	No	No	No	Yes	Yes	No	No	Yes
50th-Percentile Queue Length [veh/ln]	7.45	7.15	5.58	13.22	15.69	3.35	2.31	4.20
50th-Percentile Queue Length [ft/ln]	186.23	178.68	139.38	330.51	392.26	83.78	57.84	105.00
95th-Percentile Queue Length [veh/ln]	11.93	11.53	9.45	19.18	22.19	6.03	4.16	7.56
95th-Percentile Queue Length [ft/ln]	298.13	288.29	236.18	479.58	554.66	150.81	104.11	189.00

**Movement, Approach, & Intersection Results**

d_M, Delay for Movement [s/veh]	0.00	30.88	29.73	61.44	22.28	0.00	52.56	34.13	0.00	59.18	0.00	43.28
Movement LOS		C	C	E	C		D	C		E		D
d_A, Approach Delay [s/veh]	30.80			26.87			50.19			48.39		
Approach LOS	C			C			D			D		
d_I, Intersection Delay [s/veh]	36.43											
Intersection LOS	D											
Intersection V/C	0.814											

**Emissions**

Vehicle Miles Traveled [mph]	93.06	31.02	28.79	216.55	136.26	20.12	12.63	26.72
Stops [stops/h]	670.86	214.56	167.36	793.75	942.05	100.61	138.90	252.18
Fuel consumption [US gal/h]	13.52	4.37	4.25	19.13	21.32	2.39	3.07	5.25
CO [g/h]	945.01	305.12	296.93	1337.14	1489.99	167.14	214.56	366.97
NOx [g/h]	183.86	59.36	57.77	260.16	289.90	32.52	41.75	71.40
VOC [g/h]	219.01	70.71	68.82	309.90	345.32	38.74	49.73	85.05

**Other Modes**

g_Walk,mi, Effective Walk Time [s]	9.0	0.0	9.0	9.0
M_corner, Corner Circulation Area [ft <sup>2</sup> /ped]	0.00	0.00	0.00	0.00
M_CW, Crosswalk Circulation Area [ft <sup>2</sup> /ped]	653.53	0.00	0.00	0.00
d_p, Pedestrian Delay [s]	51.30	0.00	51.30	51.30
I_p,int, Pedestrian LOS Score for Intersectio	2.906	0.000	2.421	2.484
Crosswalk LOS	C	F	B	B
s_b, Saturation Flow Rate of the bicycle lane	2000	2000	2000	2000
c_b, Capacity of the bicycle lane [bicycles/h]	594	1011	510	225
d_b, Bicycle Delay [s]	29.64	14.67	33.26	47.22
I_b,int, Bicycle LOS Score for Intersection	2.079	2.762	3.419	1.560
Bicycle LOS	B	C	C	A

**Sequence**

Ring 1	-	2	3	4	-	-	-	-	-	-	-	-	-	-	-
Ring 2	5	6	7	8	-	-	-	-	-	-	-	-	-	-	-
Ring 3	-	-	-	-	-	-	-	-	-	-	-	-	-	-	-
Ring 4	-	-	-	-	-	-	-	-	-	-	-	-	-	-	-

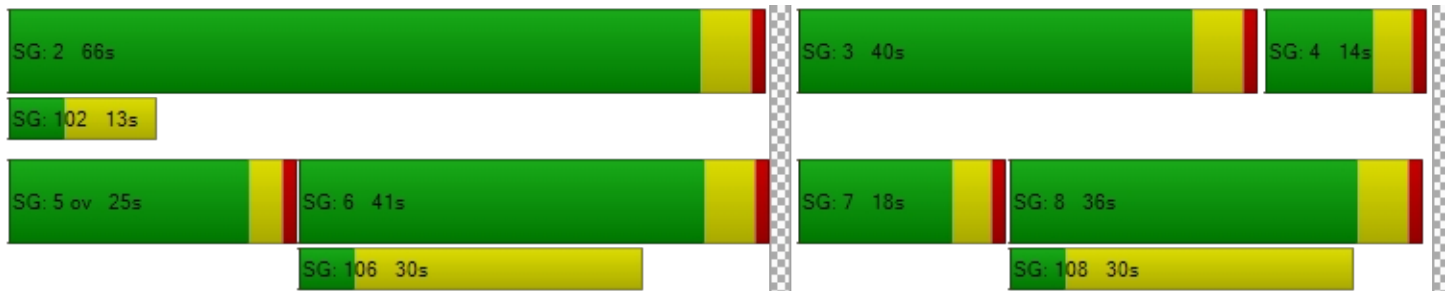



**Intersection Level Of Service Report**  
**Intersection 6: Tassajara Road & Fallon Road**

Control Type:	Signalized	Delay (sec / veh):	26.7
Analysis Method:	HCM 7th Edition	Level Of Service:	C
Analysis Period:	15 minutes	Volume to Capacity (v/c):	0.733

**Intersection Setup**

Name	Fallon Road			Fallon Road			Tassajara Road			Syrah Drive		
Approach	Northbound			Southbound			Eastbound			Westbound		
Lane Configuration												
Turning Movement	Left	Thru	Right	Left	Thru	Right	Left	Thru	Right	Left	Thru	Right
Lane Width [ft]	12.00	12.00	12.00	12.00	12.00	12.00	12.00	12.00	12.00	12.00	12.00	12.00
No. of Lanes in Entry Pocket	1	0	1	1	0	2	1	0	1	1	0	1
Entry Pocket Length [ft]	175.00	100.00	175.00	175.00	100.00	225.00	475.00	100.00	175.00	100.00	100.00	100.00
No. of Lanes in Exit Pocket	0	0	0	0	0	0	0	0	0	0	0	0
Exit Pocket Length [ft]	0.00	0.00	0.00	0.00	0.00	0.00	0.00	0.00	0.00	0.00	0.00	0.00
Speed [mph]	30.00			30.00			30.00			30.00		
Grade [%]	0.00			0.00			0.00			0.00		
Curb Present	No			No			No			No		
Crosswalk	Yes			Yes			Yes			Yes		



**Volumes**

Name	Fallon Road			Fallon Road			Tassajara Road			Syrah Drive		
Base Volume Input [veh/h]	216	455	13	2	409	673	255	12	206	18	38	16
Base Volume Adjustment Factor	1.0000	1.0000	1.0000	1.0000	1.0000	1.0000	1.0000	1.0000	1.0000	1.0000	1.0000	1.0000
Heavy Vehicles Percentage [%]	1.00	1.70	0.00	0.00	0.60	0.20	1.40	0.00	0.50	0.00	0.00	0.00
Proportion of CAVs [%]	0.00											
Growth Factor	1.0000	1.0000	1.0000	1.0000	1.0000	1.0000	1.0000	1.0000	1.0000	1.0000	1.0000	1.0000
In-Process Volume [veh/h]	0	0	0	0	0	0	0	0	0	0	0	0
Site-Generated Trips [veh/h]	0	0	0	0	0	0	0	0	0	0	0	0
Diverted Trips [veh/h]	0	0	0	0	0	0	0	0	0	0	0	0
Pass-by Trips [veh/h]	0	0	0	0	0	0	0	0	0	0	0	0
Existing Site Adjustment Volume [veh/h]	0	0	0	0	0	0	0	0	0	0	0	0
Other Volume [veh/h]	0	0	0	0	0	0	0	0	0	0	0	0
Right Turn on Red Volume [veh/h]	0	0	0	0	0	0	0	0	0	0	0	0
Total Hourly Volume [veh/h]	216	455	13	2	409	673	255	12	206	18	38	16
Peak Hour Factor	0.7800	0.7800	0.7800	0.7800	0.7800	0.7800	0.7800	0.7800	0.7800	0.7800	0.7800	0.7800
Other Adjustment Factor	1.0000	1.0000	1.0000	1.0000	1.0000	1.0000	1.0000	1.0000	1.0000	1.0000	1.0000	1.0000
Total 15-Minute Volume [veh/h]	69	146	4	1	131	216	82	4	66	6	12	5
Total Analysis Volume [veh/h]	277	583	17	3	524	863	327	15	264	23	49	21
Presence of On-Street Parking	No		No	No		No	No		No	No		No
On-Street Parking Maneuver Rate [/h]	0	0	0	0	0	0	0	0	0	0	0	0
Local Bus Stopping Rate [/h]	0	0	0	0	0	0	0	0	0	0	0	0
v_do, Outbound Pedestrian Volume crossing	1			0			0			0		
v_di, Inbound Pedestrian Volume crossing m	0			0			1			0		
v_co, Outbound Pedestrian Volume crossing	0			0			1			0		
v_ci, Inbound Pedestrian Volume crossing mi	0			1			0			0		
v_ab, Corner Pedestrian Volume [ped/h]	0			0			0			0		
Bicycle Volume [bicycles/h]	0			0			0			0		



**Intersection Settings**

Located in CBD	No
Signal Coordination Group	-
Cycle Length [s]	90
Active Pattern	Free Running (No Pattern)
Coordination Type	<i>Free Running</i>
Actuation Type	<i>Fully actuated</i>
Offset [s]	0.0
Offset Reference	Lead Green - Beginning of First Green
Permissive Mode	SingleBand
Lost time [s]	12.00

**Phasing & Timing (Basic)**

Control Type	Protecte	Permiss	Permiss	Protecte	Permiss	Permiss	Protecte	Permiss	Permiss	Protecte	Permiss	Permiss
Signal Group	3	8	0	7	4	0	5	2	0	1	6	0
Auxiliary Signal Groups												
Maximum Green [s]	25	50	0	25	50	0	35	30	0	20	30	0
Amber [s]	3.5	4.8	0.0	3.5	4.8	0.0	3.5	5.0	0.0	3.0	3.6	0.0
All red [s]	1.0	1.0	0.0	1.0	1.0	0.0	1.0	1.0	0.0	1.0	1.0	0.0
Walk [s]	0	4	0	0	0	0	0	4	0	0	3	0
Pedestrian Clearance [s]	0	25	0	0	0	0	0	28	0	0	36	0
Delayed Vehicle Green [s]	0.0	0.0	0.0	0.0	0.0	0.0	0.0	0.0	0.0	0.0	0.0	0.0
Rest In Walk		No			No			No			No	
I1, Start-Up Lost Time [s]	2.0	2.0	0.0	2.0	2.0	0.0	2.0	2.0	0.0	2.0	2.0	0.0
I2, Clearance Lost Time [s]	2.0	2.0	0.0	2.0	2.0	0.0	2.0	2.0	0.0	2.0	2.0	0.0
Detector Location [ft]	0.0	0.0	0.0	0.0	0.0	0.0	0.0	0.0	0.0	0.0	0.0	0.0
Detector Length [ft]	0.0	0.0	0.0	0.0	0.0	0.0	0.0	0.0	0.0	0.0	0.0	0.0
I, Upstream Filtering Factor	1.00	1.00	1.00	1.00	1.00	1.00	1.00	1.00	1.00	1.00	1.00	1.00

**Phasing & Timing: Free Running (No Pattern)**

Split [s]	0	0	0	0	0	0	0	0	0	0	0	0
Lead / Lag	Lead	-	-	Lead	-	-	Lead	-	-	Lead	-	-
Minimum Green [s]	9	10	0	9	10	0	11	8	0	12	9	0
Vehicle Extension [s]	3.0	3.0	0.0	3.0	3.0	0.0	3.0	3.0	0.0	3.0	3.0	0.0
Minimum Recall	No	No		No	No		Yes	No		No	No	
Maximum Recall	No	No		No	No		No	No		No	No	
Pedestrian Recall	No	No		No	No		No	No		No	No	

**Exclusive Pedestrian Phase**

Pedestrian Signal Group	0
Pedestrian Walk [s]	0
Pedestrian Clearance [s]	0



**Lane Group Calculations**

Lane Group	L	C	R	L	C	R	L	C	R	L	C	R
C, Cycle Length [s]	89	89	89	89	89	89	89	89	89	89	89	89
L, Total Lost Time per Cycle [s]	4.00	4.00	4.00	4.00	4.00	4.00	4.00	4.00	4.00	4.00	4.00	4.00
l1_p, Permitted Start-Up Lost Time [s]	0.00	0.00	0.00	0.00	0.00	0.00	0.00	0.00	0.00	0.00	0.00	0.00
l2, Clearance Lost Time [s]	2.00	2.00	2.00	2.00	2.00	2.00	2.00	2.00	2.00	2.00	2.00	2.00
g_i, Effective Green Time [s]	16	48	48	1	33	33	12	19	19	5	12	12
g / C, Green / Cycle	0.18	0.54	0.54	0.01	0.37	0.37	0.13	0.21	0.21	0.06	0.14	0.14
(v / s)_i Volume / Saturation Flow Rate	0.15	0.16	0.01	0.00	0.15	0.30	0.09	0.01	0.16	0.01	0.03	0.01
s, saturation flow rate [veh/h]	1795	3569	1615	1810	3600	2854	3475	1900	1606	1810	1900	1615
c, Capacity [veh/h]	328	1923	870	23	1328	1052	450	399	337	106	265	225
d1, Uniform Delay [s]	35.16	11.32	9.57	43.47	20.77	25.44	37.27	28.02	33.26	39.97	33.86	33.43
k, delay calibration	0.12	0.11	0.11	0.11	0.11	0.11	0.11	0.11	0.11	0.11	0.11	0.11
l, Upstream Filtering Factor	1.00	1.00	1.00	1.00	1.00	1.00	1.00	1.00	1.00	1.00	1.00	1.00
d2, Incremental Delay [s]	6.24	0.09	0.01	2.45	0.19	1.65	2.27	0.04	3.99	1.01	0.33	0.18
d3, Initial Queue Delay [s]	0.00	0.00	0.00	0.00	0.00	0.00	0.00	0.00	0.00	0.00	0.00	0.00
Rp, platoon ratio	1.00	1.00	1.00	1.00	1.00	1.00	1.00	1.00	1.00	1.00	1.00	1.00
PF, progression factor	1.00	1.00	1.00	1.00	1.00	1.00	1.00	1.00	1.00	1.00	1.00	1.00

**Lane Group Results**

X, volume / capacity	0.84	0.30	0.02	0.13	0.39	0.82	0.73	0.04	0.78	0.22	0.19	0.09
d, Delay for Lane Group [s/veh]	41.40	11.41	9.58	45.92	20.96	27.09	39.53	28.06	37.25	40.98	34.20	33.60
Lane Group LOS	D	B	A	D	C	C	D	C	D	D	C	C
Critical Lane Group	Yes	No	No	No	No	Yes	No	No	Yes	Yes	No	No
50th-Percentile Queue Length [veh/ln]	6.24	2.99	0.15	0.08	3.93	8.10	3.50	0.26	5.63	0.50	0.95	0.40
50th-Percentile Queue Length [ft/ln]	155.91	74.74	3.71	2.01	98.32	202.58	87.56	6.39	140.68	12.61	23.72	10.05
95th-Percentile Queue Length [veh/ln]	10.33	5.38	0.27	0.14	7.08	12.77	6.30	0.46	9.52	0.91	1.71	0.72
95th-Percentile Queue Length [ft/ln]	258.30	134.53	6.68	3.62	176.97	319.30	157.60	11.51	237.94	22.69	42.70	18.10



**Movement, Approach, & Intersection Results**

d_M, Delay for Movement [s/veh]	41.40	11.41	9.58	45.92	20.96	27.09	39.53	28.06	37.25	40.98	34.20	33.60
Movement LOS	D	B	A	D	C	C	D	C	D	D	C	C
d_A, Approach Delay [s/veh]	20.85			24.82			38.25			35.74		
Approach LOS	C			C			D			D		
d_I, Intersection Delay [s/veh]	26.73											
Intersection LOS	C											
Intersection V/C	0.733											

**Emissions**

Vehicle Miles Traveled [mph]	26.40	55.56	1.62	0.33	56.88	93.67	42.17	1.93	34.05	0.83	1.76	0.75
Stops [stops/h]	252.47	242.04	6.01	3.26	318.42	656.09	283.56	10.35	227.81	20.41	38.42	16.28
Fuel consumption [US gal/h]	4.82	4.98	0.13	0.06	6.34	12.24	5.93	0.22	4.66	0.34	0.63	0.26
CO [g/h]	336.58	347.97	9.30	4.15	442.87	855.46	414.74	15.55	325.81	23.66	43.73	18.49
NOx [g/h]	65.49	67.70	1.81	0.81	86.17	166.44	80.69	3.03	63.39	4.60	8.51	3.60
VOC [g/h]	78.01	80.65	2.16	0.96	102.64	198.26	96.12	3.60	75.51	5.48	10.13	4.29

**Other Modes**

g_Walk,mi, Effective Walk Time [s]	8.0			7.0			-5.8			8.0		
M_corner, Corner Circulation Area [ft <sup>2</sup> /ped]	0.00			0.00			0.00			0.00		
M_CW, Crosswalk Circulation Area [ft <sup>2</sup> /ped]	0.00			0.00			0.00			0.00		
d_p, Pedestrian Delay [s]	36.82			37.74			50.45			36.82		
I_p,int, Pedestrian LOS Score for Intersectio	2.729			2.920			2.759			2.164		
Crosswalk LOS	B			C			C			B		
s_b, Saturation Flow Rate of the bicycle lane	2000			2000			2000			2000		
c_b, Capacity of the bicycle lane [bicycles/h]	1125			1125			675			675		
d_b, Bicycle Delay [s]	8.52			8.52			19.52			19.52		
I_b,int, Bicycle LOS Score for Intersection	2.283			2.706			2.560			1.713		
Bicycle LOS	B			B			B			A		

**Sequence**

Ring 1	1	2	3	4	-	-	-	-	-	-	-	-	-	-	-
Ring 2	5	6	7	8	-	-	-	-	-	-	-	-	-	-	-
Ring 3	-	-	-	-	-	-	-	-	-	-	-	-	-	-	-
Ring 4	-	-	-	-	-	-	-	-	-	-	-	-	-	-	-

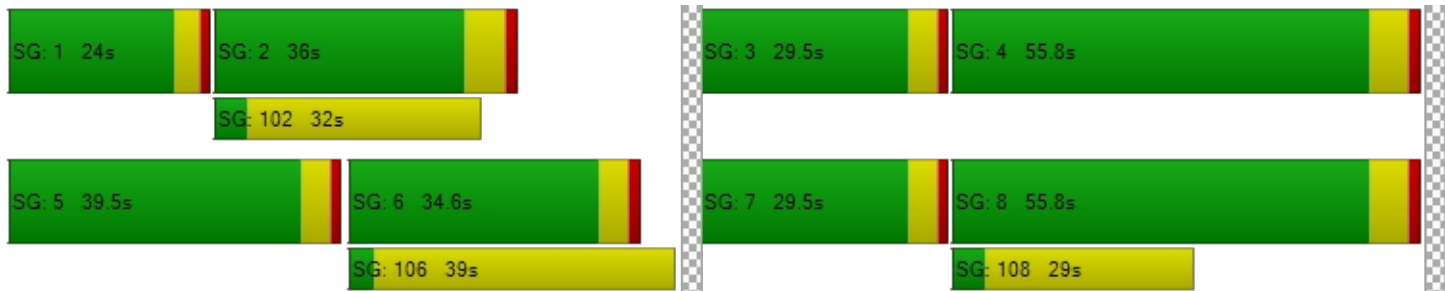

**Intersection Level Of Service Report**  
**Intersection 7: Fallon Road & Positano Parkway**

Control Type:	Signalized	Delay (sec / veh):	94.2
Analysis Method:	HCM 7th Edition	Level Of Service:	F
Analysis Period:	15 minutes	Volume to Capacity (v/c):	1.087

**Intersection Setup**

Name	Fallon Road		Fallon Road		Positano Parkway	
Approach	Northbound		Southbound		Westbound	
Lane Configuration	↑↑↑↔		↔↑↑↑		↔↔↔	
Turning Movement	Thru	Right	Left	Thru	Left	Right
Lane Width [ft]	12.00	12.00	12.00	12.00	12.00	12.00
No. of Lanes in Entry Pocket	0	1	1	0	1	1
Entry Pocket Length [ft]	100.00	225.00	325.00	100.00	375.00	425.00
No. of Lanes in Exit Pocket	0	0	0	0	0	0
Exit Pocket Length [ft]	0.00	0.00	0.00	0.00	0.00	0.00
Speed [mph]	30.00		30.00		30.00	
Grade [%]	0.00		0.00		0.00	
Curb Present	No		No		No	
Crosswalk	Yes		Yes		Yes	



**Volumes**

Name	Fallon Road		Fallon Road		Positano Parkway	
Base Volume Input [veh/h]	531	195	381	681	566	740
Base Volume Adjustment Factor	1.0000	1.0000	1.0000	1.0000	1.0000	1.0000
Heavy Vehicles Percentage [%]	2.90	0.50	0.30	0.60	0.00	0.70
Proportion of CAVs [%]	0.00					
Growth Factor	1.0000	1.0000	1.0000	1.0000	1.0000	1.0000
In-Process Volume [veh/h]	0	0	0	0	0	0
Site-Generated Trips [veh/h]	0	0	0	0	0	0
Diverted Trips [veh/h]	0	0	0	0	0	0
Pass-by Trips [veh/h]	0	0	0	0	0	0
Existing Site Adjustment Volume [veh/h]	0	0	0	0	0	0
Other Volume [veh/h]	0	0	0	0	0	0
Right Turn on Red Volume [veh/h]	0	0	0	0	0	0
Total Hourly Volume [veh/h]	531	195	381	681	566	740
Peak Hour Factor	0.8400	0.8400	0.8400	0.8400	0.8400	0.8400
Other Adjustment Factor	1.0000	1.0000	1.0000	1.0000	1.0000	1.0000
Total 15-Minute Volume [veh/h]	158	58	113	203	168	220
Total Analysis Volume [veh/h]	632	232	454	811	674	881
Presence of On-Street Parking	No	No	No	No	No	No
On-Street Parking Maneuver Rate [/h]	0	0	0	0	0	0
Local Bus Stopping Rate [/h]	0	0	0	0	0	0
v_do, Outbound Pedestrian Volume crossing	0		2		2	
v_di, Inbound Pedestrian Volume crossing m	0		2		2	
v_co, Outbound Pedestrian Volume crossing	0		0		1	
v_ci, Inbound Pedestrian Volume crossing mi	1		0		0	
v_ab, Corner Pedestrian Volume [ped/h]	0		0		0	
Bicycle Volume [bicycles/h]	0		0		2	

**Intersection Settings**

Located in CBD	No
Signal Coordination Group	-
Cycle Length [s]	90
Active Pattern	Free Running (No Pattern)
Coordination Type	<i>Free Running</i>
Actuation Type	<i>Fully actuated</i>
Offset [s]	0.0
Offset Reference	Lead Green - Beginning of First Green
Permissive Mode	SingleBand
Lost time [s]	9.00

**Phasing & Timing (Basic)**

Control Type	Permissive	Permissive	Protected	Permissive	Permissive	Permissive
Signal Group	4	0	7	8	6	0
Auxiliary Signal Groups						
Maximum Green [s]	30	0	20	30	24	0
Amber [s]	4.3	0.0	3.5	4.3	4.0	0.0
All red [s]	1.0	0.0	1.0	1.0	1.0	0.0
Walk [s]	0	0	0	4	4	0
Pedestrian Clearance [s]	0	0	0	20	34	0
Delayed Vehicle Green [s]	0.0	0.0	0.0	0.0	0.0	0.0
Rest In Walk	No			No	No	
I1, Start-Up Lost Time [s]	2.0	0.0	2.0	2.0	2.0	0.0
I2, Clearance Lost Time [s]	2.0	0.0	2.0	2.0	2.0	0.0
Detector Location [ft]	0.0	0.0	0.0	0.0	0.0	0.0
Detector Length [ft]	20.0	0.0	20.0	20.0	20.0	0.0
I, Upstream Filtering Factor	1.00	1.00	1.00	1.00	1.00	1.00

**Phasing & Timing: Free Running (No Pattern)**

Split [s]	14	0	9	14	9	0
Lead / Lag	-	-	Lead	-	Lead	-
Minimum Green [s]	10	0	5	10	5	0
Vehicle Extension [s]	3.0	0.0	3.0	3.0	3.0	0.0
Minimum Recall	Yes		No	Yes	No	
Maximum Recall	No		No	No	No	
Pedestrian Recall	No		No	No	No	

**Exclusive Pedestrian Phase**

Pedestrian Signal Group	0
Pedestrian Walk [s]	0
Pedestrian Clearance [s]	0





**Lane Group Calculations**

Lane Group	C	R	L	C	L	R
C, Cycle Length [s]	74	74	74	74	74	74
L, Total Lost Time per Cycle [s]	4.00	4.00	4.00	4.00	4.00	4.00
l1_p, Permitted Start-Up Lost Time [s]	0.00	0.00	0.00	0.00	0.00	0.00
l2, Clearance Lost Time [s]	2.00	2.00	2.00	2.00	2.00	2.00
g_i, Effective Green Time [s]	16	16	20	41	25	25
g / C, Green / Cycle	0.22	0.22	0.28	0.55	0.34	0.34
(v / s)_i Volume / Saturation Flow Rate	0.12	0.14	0.25	0.16	0.19	0.56
s, saturation flow rate [veh/h]	5057	1606	1805	5151	3514	1579
c, Capacity [veh/h]	1110	353	502	2842	1193	536
d1, Uniform Delay [s]	25.63	26.20	25.64	8.78	19.86	24.10
k, delay calibration	0.11	0.11	0.38	0.11	0.11	0.50
l, Upstream Filtering Factor	1.00	1.00	1.00	1.00	1.00	1.00
d2, Incremental Delay [s]	0.46	2.09	18.05	0.05	0.42	297.60
d3, Initial Queue Delay [s]	0.00	0.00	0.00	0.00	0.00	0.00
Rp, platoon ratio	1.00	1.00	1.00	1.00	1.00	1.00
PF, progression factor	1.00	1.00	1.00	1.00	1.00	1.00

**Lane Group Results**

X, volume / capacity	0.57	0.66	0.90	0.29	0.56	1.64
d, Delay for Lane Group [s/veh]	26.09	28.30	43.69	8.83	20.28	321.70
Lane Group LOS	C	C	D	A	C	F
Critical Lane Group	No	Yes	Yes	No	No	Yes
50th-Percentile Queue Length [veh/ln]	3.19	3.75	9.71	2.03	4.49	52.86
50th-Percentile Queue Length [ft/ln]	79.83	93.68	242.77	50.75	112.15	1321.48
95th-Percentile Queue Length [veh/ln]	5.75	6.75	14.82	3.65	7.96	82.88
95th-Percentile Queue Length [ft/ln]	143.70	168.63	370.53	91.35	198.99	2072.10

**Movement, Approach, & Intersection Results**

d_M, Delay for Movement [s/veh]	26.09	28.30	43.69	8.83	20.28	321.70
Movement LOS	C	C	D	A	C	F
d_A, Approach Delay [s/veh]	26.68		21.34		191.05	
Approach LOS	C		C		F	
d_I, Intersection Delay [s/veh]	94.23					
Intersection LOS	F					
Intersection V/C	1.087					

**Emissions**

Vehicle Miles Traveled [mph]	158.95	58.35	39.83	71.15	80.82	105.64
Stops [stops/h]	469.15	183.52	475.55	298.26	439.40	2588.64
Fuel consumption [US gal/h]	12.49	4.75	8.30	6.03	8.54	76.32
CO [g/h]	873.11	332.16	580.41	421.85	596.74	5334.43
NOx [g/h]	169.88	64.63	112.93	82.08	116.10	1037.89
VOC [g/h]	202.35	76.98	134.52	97.77	138.30	1236.31

**Other Modes**

g_Walk,mi, Effective Walk Time [s]	8.0		8.0		8.7	
M_corner, Corner Circulation Area [ft <sup>2</sup> /ped]	0.00		0.00		0.00	
M_CW, Crosswalk Circulation Area [ft <sup>2</sup> /ped]	0.00		0.00		0.00	
d_p, Pedestrian Delay [s]	29.19		29.19		28.57	
I_p,int, Pedestrian LOS Score for Intersectio	2.914		2.973		2.669	
Crosswalk LOS	C		C		B	
s_b, Saturation Flow Rate of the bicycle lane	2000		2000		2000	
c_b, Capacity of the bicycle lane [bicycles/h]	816		816		653	
d_b, Bicycle Delay [s]	12.88		12.88		16.69	
I_b,int, Bicycle LOS Score for Intersection	2.035		2.255		1.560	
Bicycle LOS	B		B		A	

**Sequence**

Ring 1	-	-	-	8	-	-	-	-	-	-	-	-	-	-	-	-
Ring 2	-	6	7	4	-	-	-	-	-	-	-	-	-	-	-	-
Ring 3	-	-	-	-	-	-	-	-	-	-	-	-	-	-	-	-
Ring 4	-	-	-	-	-	-	-	-	-	-	-	-	-	-	-	-



**Intersection Level Of Service Report**  
**Intersection 8: Fallon Road & Central Parkway**

Control Type:	Signalized	Delay (sec / veh):	32.8
Analysis Method:	HCM 7th Edition	Level Of Service:	C
Analysis Period:	15 minutes	Volume to Capacity (v/c):	0.585

**Intersection Setup**

Name	Fallon Road			Fallon Road			Central Parkway			Central Parkway		
Approach	Northbound			Southbound			Eastbound			Westbound		
Lane Configuration												
Turning Movement	Left	Thru	Right	Left	Thru	Right	Left	Thru	Right	Left	Thru	Right
Lane Width [ft]	12.00	12.00	12.00	12.00	12.00	12.00	12.00	12.00	12.00	12.00	12.00	12.00
No. of Lanes in Entry Pocket	2	0	1	1	0	1	2	0	2	2	0	1
Entry Pocket Length [ft]	300.00	100.00	255.00	295.00	100.00	245.00	350.00	100.00	230.00	250.00	100.00	250.00
No. of Lanes in Exit Pocket	0	0	0	0	0	2	0	0	0	0	0	0
Exit Pocket Length [ft]	0.00	0.00	0.00	0.00	0.00	500.00	0.00	0.00	0.00	0.00	0.00	0.00
Speed [mph]	40.00			30.00			25.00			30.00		
Grade [%]	0.00			0.00			0.00			0.00		
Curb Present	Yes			Yes			Yes			Yes		
Crosswalk	Yes			Yes			Yes			Yes		



**Volumes**

Name	Fallon Road			Fallon Road			Central Parkway			Central Parkway		
	Base Volume Input [veh/h]	68	709	141	73	1004	66	59	175	91	277	181
Base Volume Adjustment Factor	1.0000	1.0000	1.0000	1.0000	1.0000	1.0000	1.0000	1.0000	1.0000	1.0000	1.0000	1.0000
Heavy Vehicles Percentage [%]	6.00	1.20	0.70	0.00	0.40	1.80	0.00	0.60	3.30	0.00	0.60	1.20
Proportion of CAVs [%]	0.00											
Growth Factor	1.0000	1.0000	1.0000	1.0000	1.0000	1.0000	1.0000	1.0000	1.0000	1.0000	1.0000	1.0000
In-Process Volume [veh/h]	0	0	0	0	0	0	0	0	0	0	0	0
Site-Generated Trips [veh/h]	0	0	0	0	0	0	0	0	0	0	0	0
Diverted Trips [veh/h]	0	0	0	0	0	0	0	0	0	0	0	0
Pass-by Trips [veh/h]	0	0	0	0	0	0	0	0	0	0	0	0
Existing Site Adjustment Volume [veh/h]	0	0	0	0	0	0	0	0	0	0	0	0
Other Volume [veh/h]	0	0	0	0	0	0	0	0	0	0	0	0
Right Turn on Red Volume [veh/h]	0	0	0	0	0	0	0	0	0	0	0	0
Total Hourly Volume [veh/h]	68	709	141	73	1004	66	59	175	91	277	181	84
Peak Hour Factor	0.7500	0.7500	0.7500	0.7500	0.7500	0.7500	0.7500	0.7500	0.7500	0.7500	0.7500	0.7500
Other Adjustment Factor	1.0000	1.0000	1.0000	1.0000	1.0000	1.0000	1.0000	1.0000	1.0000	1.0000	1.0000	1.0000
Total 15-Minute Volume [veh/h]	23	236	47	24	335	22	20	58	30	92	60	28
Total Analysis Volume [veh/h]	91	945	188	97	1339	88	79	233	121	369	241	112
Presence of On-Street Parking	No		No	No		No	No		No	No		No
On-Street Parking Maneuver Rate [/h]	0	0	0	0	0	0	0	0	0	0	0	0
Local Bus Stopping Rate [/h]	0	0	0	0	0	0	0	0	0	0	0	0
v_do, Outbound Pedestrian Volume crossing	1			2			2			1		
v_di, Inbound Pedestrian Volume crossing m	1			2			2			1		
v_co, Outbound Pedestrian Volume crossing	44			4			43			4		
v_ci, Inbound Pedestrian Volume crossing mi	43			4			44			4		
v_ab, Corner Pedestrian Volume [ped/h]	0			0			0			0		
Bicycle Volume [bicycles/h]	1			0			6			0		



**Intersection Settings**

Located in CBD	No
Signal Coordination Group	-
Cycle Length [s]	90
Active Pattern	Free Running (No Pattern)
Coordination Type	<i>Free Running</i>
Actuation Type	<i>Fully actuated</i>
Offset [s]	0.0
Offset Reference	Lead Green - Beginning of First Green
Permissive Mode	SingleBand
Lost time [s]	12.00

**Phasing & Timing (Basic)**

Control Type	Protecte	Permiss	Permiss	Protecte	Permiss	Permiss	Protecte	Permiss	Permiss	Protecte	Permiss	Permiss
Signal Group	3	8	0	7	4	0	5	2	0	1	6	0
Auxiliary Signal Groups												
Maximum Green [s]	20	30	0	20	30	0	20	30	0	20	30	0
Amber [s]	3.5	4.3	0.0	3.0	4.3	0.0	3.0	4.0	0.0	3.0	4.0	0.0
All red [s]	1.0	1.0	0.0	1.0	1.0	0.0	1.0	1.0	0.0	1.0	1.0	0.0
Walk [s]	0	4	0	0	4	0	0	4	0	0	4	0
Pedestrian Clearance [s]	0	28	0	0	34	0	0	42	0	0	41	0
Delayed Vehicle Green [s]	0.0	0.0	0.0	0.0	0.0	0.0	0.0	0.0	0.0	0.0	0.0	0.0
Rest In Walk		No			No			No			No	
I1, Start-Up Lost Time [s]	2.0	2.0	0.0	2.0	2.0	0.0	2.0	2.0	0.0	2.0	2.0	0.0
I2, Clearance Lost Time [s]	2.0	2.0	0.0	2.0	2.0	0.0	2.0	2.0	0.0	2.0	2.0	0.0
Detector Location [ft]	0.0	0.0	0.0	0.0	0.0	0.0	0.0	0.0	0.0	0.0	0.0	0.0
Detector Length [ft]	20.0	20.0	0.0	0.0	0.0	0.0	20.0	20.0	0.0	20.0	20.0	0.0
I, Upstream Filtering Factor	1.00	1.00	1.00	1.00	1.00	1.00	1.00	1.00	1.00	1.00	1.00	1.00

**Phasing & Timing: Free Running (No Pattern)**

Split [s]	0	0	0	0	0	0	0	0	0	0	0	0
Lead / Lag	Lead	-	-	Lead	-	-	Lead	-	-	Lead	-	-
Minimum Green [s]	10	12	0	10	12	0	10	12	0	10	12	0
Vehicle Extension [s]	2.0	4.0	0.0	2.0	4.0	0.0	2.0	4.0	0.0	2.0	4.0	0.0
Minimum Recall	No	Yes		No	Yes		No	No		No	No	
Maximum Recall	No	No		No	No		No	No		No	No	
Pedestrian Recall	No	No		No	No		No	No		No	No	

**Exclusive Pedestrian Phase**

Pedestrian Signal Group	0
Pedestrian Walk [s]	0
Pedestrian Clearance [s]	0



**Lane Group Calculations**

Lane Group	L	C	R	L	C	R	L	C	R	L	C	R
C, Cycle Length [s]	101	101	101	101	101	101	101	101	101	101	101	101
L, Total Lost Time per Cycle [s]	4.00	4.00	4.00	4.00	4.00	4.00	4.00	4.00	4.00	4.00	4.00	4.00
l1_p, Permitted Start-Up Lost Time [s]	0.00	0.00	0.00	0.00	0.00	0.00	0.00	0.00	0.00	0.00	0.00	0.00
l2, Clearance Lost Time [s]	2.00	2.00	2.00	2.00	2.00	2.00	2.00	2.00	2.00	2.00	2.00	2.00
g_i, Effective Green Time [s]	10	31	31	9	31	31	9	31	31	13	35	35
g / C, Green / Cycle	0.10	0.31	0.31	0.09	0.31	0.31	0.09	0.31	0.31	0.13	0.35	0.35
(v / s)_i Volume / Saturation Flow Rate	0.03	0.18	0.12	0.05	0.26	0.06	0.02	0.12	0.09	0.11	0.13	0.07
s, saturation flow rate [veh/h]	3348	5127	1567	1810	5159	1586	3514	1891	1417	3514	1891	1589
c, Capacity [veh/h]	326	1596	488	170	1587	488	315	582	436	451	655	551
d1, Uniform Delay [s]	42.18	29.29	27.06	43.72	32.62	25.57	42.72	27.54	26.16	42.75	24.65	23.13
k, delay calibration	0.04	0.15	0.15	0.04	0.15	0.15	0.04	0.15	0.15	0.04	0.15	0.15
l, Upstream Filtering Factor	1.00	1.00	1.00	1.00	1.00	1.00	1.00	1.00	1.00	1.00	1.00	1.00
d2, Incremental Delay [s]	0.17	0.50	0.71	1.13	1.84	0.25	0.15	0.63	0.49	1.41	0.49	0.26
d3, Initial Queue Delay [s]	0.00	0.00	0.00	0.00	0.00	0.00	0.00	0.00	0.00	0.00	0.00	0.00
Rp, platoon ratio	1.00	1.00	1.00	1.00	1.00	1.00	1.00	1.00	1.00	1.00	1.00	1.00
PF, progression factor	1.00	1.00	1.00	1.00	1.00	1.00	1.00	1.00	1.00	1.00	1.00	1.00

**Lane Group Results**

X, volume / capacity	0.28	0.59	0.39	0.57	0.84	0.18	0.25	0.40	0.28	0.82	0.37	0.20
d, Delay for Lane Group [s/veh]	42.35	29.80	27.77	44.85	34.47	25.82	42.87	28.17	26.65	44.16	25.14	23.38
Lane Group LOS	D	C	C	D	C	C	D	C	C	D	C	C
Critical Lane Group	Yes	No	No	No	Yes	No	No	Yes	No	Yes	No	No
50th-Percentile Queue Length [veh/ln]	1.03	6.21	3.48	2.35	10.19	1.57	0.93	4.53	2.24	4.52	4.33	1.89
50th-Percentile Queue Length [ft/ln]	25.78	155.36	87.04	58.84	254.78	39.17	23.19	113.29	56.09	112.90	108.28	47.22
95th-Percentile Queue Length [veh/ln]	1.86	10.30	6.27	4.24	15.43	2.82	1.67	8.02	4.04	8.00	7.74	3.40
95th-Percentile Queue Length [ft/ln]	46.41	257.57	156.67	105.91	385.67	70.51	41.74	200.57	100.97	200.03	193.60	85.00



**Movement, Approach, & Intersection Results**

d_M, Delay for Movement [s/veh]	42.35	29.80	27.77	44.85	34.47	25.82	42.87	28.17	26.65	44.16	25.14	23.38
Movement LOS	D	C	C	D	C	C	D	C	C	D	C	C
d_A, Approach Delay [s/veh]	30.42			34.63			30.43			34.59		
Approach LOS	C			C			C			C		
d_I, Intersection Delay [s/veh]	32.83											
Intersection LOS	C											
Intersection V/C	0.585											

**Emissions**

Vehicle Miles Traveled [mph]	24.09	250.21	49.78	24.40	336.77	22.13	6.90	20.36	10.58	83.89	54.79	25.46
Stops [stops/h]	73.83	667.37	124.63	84.25	1094.44	56.09	66.41	162.22	80.32	323.31	155.04	67.61
Fuel consumption [US gal/h]	2.37	21.25	4.07	2.36	29.30	1.68	1.25	2.87	1.44	8.56	4.34	1.95
CO [g/h]	165.84	1485.26	284.48	164.62	2048.16	117.67	87.68	200.88	100.64	598.03	303.71	136.63
NOx [g/h]	32.27	288.98	55.35	32.03	398.50	22.89	17.06	39.08	19.58	116.36	59.09	26.58
VOC [g/h]	38.43	344.22	65.93	38.15	474.68	27.27	20.32	46.56	23.32	138.60	70.39	31.67

**Other Modes**

g_Walk,mi, Effective Walk Time [s]	8.0			8.0			8.0			8.0		
M_corner, Corner Circulation Area [ft <sup>2</sup> /ped]	0.00			0.00			0.00			0.00		
M_CW, Crosswalk Circulation Area [ft <sup>2</sup> /ped]	0.00			0.00			0.00			0.00		
d_p, Pedestrian Delay [s]	42.60			42.60			42.60			42.60		
I_p,int, Pedestrian LOS Score for Intersectio	3.371			3.234			2.701			2.549		
Crosswalk LOS	C			C			B			B		
s_b, Saturation Flow Rate of the bicycle lane	2000			2000			2000			2000		
c_b, Capacity of the bicycle lane [bicycles/h]	597			597			597			597		
d_b, Bicycle Delay [s]	24.77			24.76			24.83			24.76		
I_b,int, Bicycle LOS Score for Intersection	2.233			2.398			2.274			2.751		
Bicycle LOS	B			B			B			C		

**Sequence**

Ring 1	1	2	3	4	-	-	-	-	-	-	-	-	-	-	-
Ring 2	5	6	7	8	-	-	-	-	-	-	-	-	-	-	-
Ring 3	-	-	-	-	-	-	-	-	-	-	-	-	-	-	-
Ring 4	-	-	-	-	-	-	-	-	-	-	-	-	-	-	-

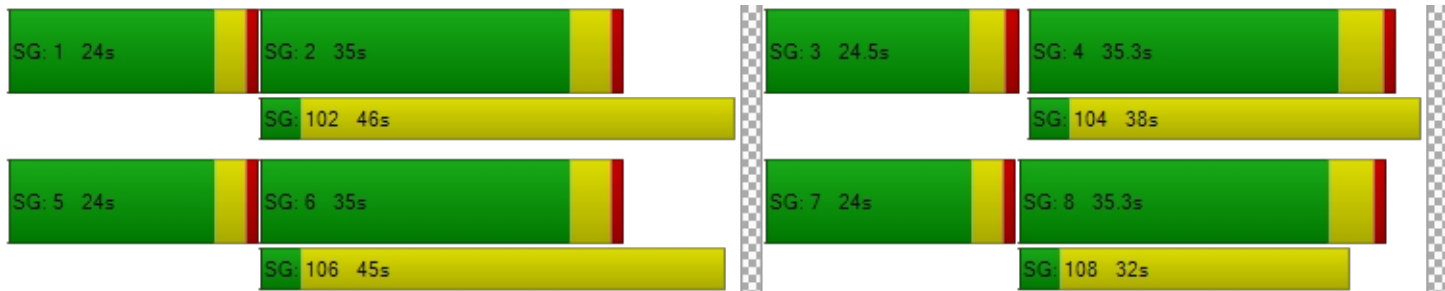

**Intersection Level Of Service Report**  
**Intersection 9: Fallon Road & Dublin Boulevard**

Control Type:	Signalized	Delay (sec / veh):	43.7
Analysis Method:	HCM 7th Edition	Level Of Service:	D
Analysis Period:	15 minutes	Volume to Capacity (v/c):	0.703

**Intersection Setup**

Name	Fallon Road			Fallon Road			Dublin Boulevard			Dublin Boulevard		
Approach	Northbound			Southbound			Eastbound			Westbound		
Lane Configuration	[Diagram]			[Diagram]			[Diagram]			[Diagram]		
Turning Movement	Left	Thru	Right	Left	Thru	Right	Left	Thru	Right	Left	Thru	Right
Lane Width [ft]	12.00	12.00	12.00	12.00	12.00	12.00	12.00	12.00	12.00	12.00	12.00	12.00
No. of Lanes in Entry Pocket	3	0	2	2	0	1	2	0	2	2	0	1
Entry Pocket Length [ft]	430.00	100.00	100.00	140.00	100.00	225.00	400.00	100.00	400.00	100.00	100.00	100.00
No. of Lanes in Exit Pocket	0	0	1	0	0	1	0	0	1	0	0	2
Exit Pocket Length [ft]	0.00	0.00	100.00	0.00	0.00	100.00	0.00	0.00	500.00	0.00	0.00	74.61
Speed [mph]	45.00			45.00			45.00			45.00		
Grade [%]	0.00			0.00			0.00			0.00		
Curb Present	Yes			Yes			Yes			Yes		
Crosswalk	No			No			Yes			Yes		





**Volumes**

Name	Fallon Road			Fallon Road			Dublin Boulevard			Dublin Boulevard		
Base Volume Input [veh/h]	294	503	210	14	1151	256	135	81	198	8	1754	245
Base Volume Adjustment Factor	1.0000	1.0000	1.0000	1.0000	1.0000	1.0000	1.0000	1.0000	1.0000	1.0000	1.0000	1.0000
Heavy Vehicles Percentage [%]	3.50	1.20	4.00	1.00	0.50	0.00	0.70	4.00	3.50	1.00	1.00	1.00
Proportion of CAVs [%]	0.00											
Growth Factor	1.0000	1.0000	1.0000	1.0000	1.0000	1.0000	1.0000	1.0000	1.0000	1.0000	1.0000	1.0000
In-Process Volume [veh/h]	0	0	0	0	0	0	0	0	0	0	0	0
Site-Generated Trips [veh/h]	0	0	0	0	0	0	0	0	0	0	0	0
Diverted Trips [veh/h]	0	0	0	0	0	0	0	0	0	0	0	0
Pass-by Trips [veh/h]	0	0	0	0	0	0	0	0	0	0	0	0
Existing Site Adjustment Volume [veh/h]	0	0	0	0	0	0	0	0	0	0	0	0
Other Volume [veh/h]	0	0	0	0	0	0	0	0	0	0	0	0
Right Turn on Red Volume [veh/h]	0	0	0	0	0	0	0	0	0	0	0	0
Total Hourly Volume [veh/h]	294	503	210	14	1151	256	135	81	198	8	1754	245
Peak Hour Factor	0.9200	0.9200	0.9400	0.9400	0.9200	0.9200	0.9200	0.9400	0.9200	0.9400	0.9400	0.9400
Other Adjustment Factor	1.0000	1.0000	1.0000	1.0000	1.0000	1.0000	1.0000	1.0000	1.0000	1.0000	1.0000	1.0000
Total 15-Minute Volume [veh/h]	80	137	56	4	313	70	37	22	54	2	466	65
Total Analysis Volume [veh/h]	320	547	223	15	1251	278	147	86	215	9	1866	261
Presence of On-Street Parking	No		No	No		No	No		No	No		No
On-Street Parking Maneuver Rate [/h]	0	0	0	0	0	0	0	0	0	0	0	0
Local Bus Stopping Rate [/h]	0	0	0	0	0	0	0	0	0	0	0	0
v_do, Outbound Pedestrian Volume crossing	0			0			0			0		
v_di, Inbound Pedestrian Volume crossing m	0			0			0			0		
v_co, Outbound Pedestrian Volume crossing	2			4			4			3		
v_ci, Inbound Pedestrian Volume crossing mi	3			4			4			2		
v_ab, Corner Pedestrian Volume [ped/h]	0			0			0			0		
Bicycle Volume [bicycles/h]	0			0			0			0		



**Intersection Settings**

Located in CBD	No
Signal Coordination Group	-
Cycle Length [s]	160
Active Pattern	Pattern 1
Coordination Type	Time of Day Pattern Isolated
Actuation Type	Fully actuated
Offset [s]	0.0
Offset Reference	Lead Green - Beginning of First Green
Permissive Mode	SingleBand
Lost time [s]	12.00

**Phasing & Timing (Basic)**

Control Type	Protecte	Permiss	Permiss	Protecte	Permiss	Permiss	Protecte	Permiss	Overlap	Protecte	Permiss	Permiss
Signal Group	3	8	0	7	4	0	5	2	2	1	6	0
Auxiliary Signal Groups									2,3			
Maximum Green [s]	30	30	0	12	30	0	30	30	30	12	12	0
Amber [s]	4.3	4.7	0.0	4.3	4.7	0.0	4.3	4.3	4.3	4.3	4.8	0.0
All red [s]	1.0	1.0	0.0	1.0	1.0	0.0	1.0	1.0	1.0	1.0	1.0	0.0
Walk [s]	0	0	0	0	4	0	0	0	0	0	0	0
Pedestrian Clearance [s]	0	0	0	0	41	0	0	0	0	0	0	0
Delayed Vehicle Green [s]	0.0	0.0	0.0	0.0	0.0	0.0	0.0	0.0	0.0	0.0	0.0	0.0
Rest In Walk		No			No			No			No	
I1, Start-Up Lost Time [s]	2.0	2.0	0.0	2.0	2.0	0.0	2.0	2.0	2.0	2.0	2.0	0.0
I2, Clearance Lost Time [s]	2.0	2.0	0.0	2.0	2.0	0.0	2.0	2.0	2.0	3.3	2.0	0.0
Detector Location [ft]	0.0	0.0	0.0	0.0	0.0	0.0	0.0	0.0	0.0	0.0	0.0	0.0
Detector Length [ft]	0.0	0.0	0.0	0.0	0.0	0.0	20.0	20.0	20.0	0.0	0.0	0.0
I, Upstream Filtering Factor	1.00	1.00	1.00	1.00	1.00	1.00	1.00	1.00	1.00	1.00	1.00	1.00

**Phasing & Timing: Pattern 1**

Split [s]	16	51	0	16	51	0	16	77	77	16	77	0
Lead / Lag	Lead	-	-	Lead	-	-	Lead	-	-	Lead	-	-
Minimum Green [s]	10	12	0	10	12	0	10	12	12	10	10	0
Vehicle Extension [s]	2.0	4.0	0.0	2.0	4.0	0.0	2.0	4.0	4.0	2.0	2.0	0.0
Minimum Recall	No	Yes		No	Yes		No	No	No	No	No	
Maximum Recall	No	No		No	No		No	No	No	No	No	
Pedestrian Recall	No	No		No	No		No	No	No	No	No	

**Exclusive Pedestrian Phase**

Pedestrian Signal Group	0
Pedestrian Walk [s]	0
Pedestrian Clearance [s]	0



**Lane Group Calculations**

Lane Group	L	C	R	L	C	R	L	C	R	L	C	R
C, Cycle Length [s]	160	160	160	160	160	160	160	160	160	160	160	160
L, Total Lost Time per Cycle [s]	4.00	4.00	4.00	4.00	4.00	4.00	4.00	4.00	4.00	5.30	4.00	4.00
l1_p, Permitted Start-Up Lost Time [s]	0.00	0.00	0.00	0.00	0.00	0.00	0.00	0.00	0.00	0.00	0.00	0.00
l2, Clearance Lost Time [s]	2.00	2.00	2.00	2.00	2.00	2.00	2.00	2.00	0.00	3.30	2.00	2.00
g_i, Effective Green Time [s]	14	63	63	6	55	55	11	71	89	3	64	64
g / C, Green / Cycle	0.09	0.39	0.39	0.04	0.34	0.34	0.07	0.44	0.55	0.02	0.40	0.40
(v / s)_i Volume / Saturation Flow Rate	0.06	0.08	0.08	0.00	0.18	0.17	0.04	0.02	0.08	0.00	0.36	0.16
s, saturation flow rate [veh/h]	5125	6835	2758	3486	6874	1604	3495	5012	2780	5230	5135	1602
c, Capacity [veh/h]	453	2673	1078	134	2345	547	247	2214	1520	108	2053	641
d1, Uniform Delay [s]	70.91	32.25	32.26	74.25	42.43	41.93	72.11	25.37	17.80	76.85	45.26	34.42
k, delay calibration	0.04	0.50	0.50	0.04	0.50	0.50	0.04	0.15	0.15	0.04	0.04	0.04
l, Upstream Filtering Factor	1.00	1.00	1.00	1.00	1.00	1.00	1.00	1.00	1.00	1.00	1.00	1.00
d2, Incremental Delay [s]	0.77	0.17	0.43	0.13	0.87	3.35	0.86	0.01	0.06	0.12	0.69	0.15
d3, Initial Queue Delay [s]	0.00	0.00	0.00	0.00	0.00	0.00	0.00	0.00	0.00	0.00	0.00	0.00
Rp, platoon ratio	1.00	1.00	1.00	1.00	1.00	1.00	1.00	1.00	1.00	1.00	1.00	1.00
PF, progression factor	1.00	1.00	1.00	1.00	1.00	1.00	1.00	1.00	1.00	1.00	1.00	1.00

**Lane Group Results**

X, volume / capacity	0.71	0.20	0.21	0.11	0.53	0.51	0.60	0.04	0.14	0.08	0.91	0.41
d, Delay for Lane Group [s/veh]	71.67	32.42	32.70	74.39	43.31	45.28	72.97	25.38	17.86	76.97	45.96	34.58
Lane Group LOS	E	C	C	E	D	D	E	C	B	E	D	C
Critical Lane Group	Yes	No	No	No	Yes	No	Yes	No	No	No	Yes	No
50th-Percentile Queue Length [veh/ln]	4.24	3.53	2.92	0.30	9.97	9.14	2.92	0.62	1.94	0.12	22.70	7.23
50th-Percentile Queue Length [ft/ln]	105.91	88.15	72.88	7.44	249.30	228.55	73.12	15.54	48.59	3.03	567.56	180.75
95th-Percentile Queue Length [veh/ln]	7.61	6.35	5.25	0.54	15.15	14.10	5.26	1.12	3.50	0.22	30.52	11.64
95th-Percentile Queue Length [ft/ln]	190.30	158.66	131.19	13.39	378.77	352.52	131.62	27.97	87.46	5.46	762.91	290.99



**Movement, Approach, & Intersection Results**

d_M, Delay for Movement [s/veh]	71.67	32.42	32.70	74.39	43.31	45.28	72.97	25.38	17.86	76.97	45.96	34.58
Movement LOS	E	C	C	E	D	D	E	C	B	E	D	C
d_A, Approach Delay [s/veh]	44.00			43.96			37.38			44.70		
Approach LOS	D			D			D			D		
d_I, Intersection Delay [s/veh]	43.71											
Intersection LOS	D											
Intersection V/C	0.703											

**Emissions**

Vehicle Miles Traveled [mph]	42.98	73.47	29.95	3.97	331.23	73.61	176.86	103.47	258.68	2.02	418.75	58.57
Stops [stops/h]	286.00	317.36	131.21	13.39	897.57	205.72	131.63	41.96	87.47	8.19	1532.57	162.69
Fuel consumption [US gal/h]	9.70	10.07	4.14	0.53	33.54	7.64	9.88	4.51	10.74	0.31	50.86	5.87
CO [g/h]	677.73	704.07	289.51	37.02	2344.31	534.17	690.72	315.43	750.43	21.81	3554.99	410.09
NOx [g/h]	131.86	136.99	56.33	7.20	456.12	103.93	134.39	61.37	146.01	4.24	691.67	79.79
VOC [g/h]	157.07	163.18	67.10	8.58	543.32	123.80	160.08	73.10	173.92	5.05	823.90	95.04

**Other Modes**

g_Walk,mi, Effective Walk Time [s]	0.0			0.0			8.0			45.3		
M_corner, Corner Circulation Area [ft <sup>2</sup> /ped]	0.00			0.00			0.00			0.00		
M_CW, Crosswalk Circulation Area [ft <sup>2</sup> /ped]	0.00			0.00			244.03			0.00		
d_p, Pedestrian Delay [s]	0.00			0.00			72.19			41.10		
I_p,int, Pedestrian LOS Score for Intersectio	0.000			0.000			3.421			3.412		
Crosswalk LOS	F			F			C			C		
s_b, Saturation Flow Rate of the bicycle lane	2000			2000			2000			2000		
c_b, Capacity of the bicycle lane [bicycles/h]	566			566			896			890		
d_b, Bicycle Delay [s]	41.10			41.10			24.36			24.63		
I_b,int, Bicycle LOS Score for Intersection	2.009			2.197			1.806			2.734		
Bicycle LOS	B			B			A			B		

**Sequence**



Ring 1	1	2	3	4	-	-	-	-	-	-	-	-	-	-	-
Ring 2	5	6	7	8	-	-	-	-	-	-	-	-	-	-	-
Ring 3	-	-	-	-	-	-	-	-	-	-	-	-	-	-	-
Ring 4	-	-	-	-	-	-	-	-	-	-	-	-	-	-	-



**Intersection Level Of Service Report**  
**Intersection 10: Fallon Road & Fallon Gateway**

Control Type:	Signalized	Delay (sec / veh):	9.6
Analysis Method:	HCM 7th Edition	Level Of Service:	A
Analysis Period:	15 minutes	Volume to Capacity (v/c):	0.332

**Intersection Setup**

Name	Fallon Road		Fallon Road		Fallon Gateway	
Approach	Northbound		Southbound		Eastbound	
Lane Configuration						
Turning Movement	Left	Thru	Thru	Right	Left	Right
Lane Width [ft]	12.00	12.00	12.00	12.00	12.00	12.00
No. of Lanes in Entry Pocket	1	0	0	1	1	1
Entry Pocket Length [ft]	275.00	100.00	100.00	100.00	210.00	210.00
No. of Lanes in Exit Pocket	0	2	0	0	0	0
Exit Pocket Length [ft]	0.00	100.00	0.00	0.00	0.00	0.00
Speed [mph]	45.00		40.00		25.00	
Grade [%]	0.00		0.00		0.00	
Curb Present	Yes		Yes		Yes	
Crosswalk	No		No		Yes	



**Volumes**

Name	Fallon Road		Fallon Road		Fallon Gateway	
Base Volume Input [veh/h]	189	871	1178	42	20	94
Base Volume Adjustment Factor	1.0000	1.0000	1.0000	1.0000	1.0000	1.0000
Heavy Vehicles Percentage [%]	1.70	4.10	1.00	0.00	0.00	4.30
Proportion of CAVs [%]	0.00					
Growth Factor	1.0000	1.0000	1.0000	1.0000	1.0000	1.0000
In-Process Volume [veh/h]	0	0	0	0	0	0
Site-Generated Trips [veh/h]	0	0	0	0	0	0
Diverted Trips [veh/h]	0	0	0	0	0	0
Pass-by Trips [veh/h]	0	0	0	0	0	0
Existing Site Adjustment Volume [veh/h]	0	0	0	0	0	0
Other Volume [veh/h]	0	0	0	0	0	0
Right Turn on Red Volume [veh/h]	0	0	0	0	0	0
Total Hourly Volume [veh/h]	189	871	1178	42	20	94
Peak Hour Factor	0.9000	0.9000	0.9000	0.9000	0.9000	0.9000
Other Adjustment Factor	1.0000	1.0000	1.0000	1.0000	1.0000	1.0000
Total 15-Minute Volume [veh/h]	53	242	327	12	6	26
Total Analysis Volume [veh/h]	210	968	1309	47	22	104
Presence of On-Street Parking	No	No	No	No	No	No
On-Street Parking Maneuver Rate [/h]	0	0	0	0	0	0
Local Bus Stopping Rate [/h]	0	0	0	0	0	0
v_do, Outbound Pedestrian Volume crossing	0		0		0	
v_di, Inbound Pedestrian Volume crossing m	0		0		0	
v_co, Outbound Pedestrian Volume crossing	0		0		0	
v_ci, Inbound Pedestrian Volume crossing mi	0		0		0	
v_ab, Corner Pedestrian Volume [ped/h]	0		0		0	
Bicycle Volume [bicycles/h]	0		0		0	



**Intersection Settings**

Located in CBD	No
Signal Coordination Group	-
Cycle Length [s]	105
Active Pattern	Pattern 1
Coordination Type	Time of Day Pattern Isolated
Actuation Type	Fully actuated
Offset [s]	0.0
Offset Reference	Lead Green - Beginning of First Green
Permissive Mode	SingleBand
Lost time [s]	9.00

**Phasing & Timing (Basic)**

Control Type	Protected	Permissive	Permissive	Permissive	Permissive	Overlap
Signal Group	3	8	4	0	2	2
Auxiliary Signal Groups						2,3
Maximum Green [s]	20	40	40	0	30	30
Amber [s]	3.5	4.7	4.7	0.0	3.5	3.5
All red [s]	1.0	1.0	1.0	0.0	1.0	1.0
Walk [s]	0	0	4	0	0	0
Pedestrian Clearance [s]	0	0	28	0	0	0
Delayed Vehicle Green [s]	0.0	0.0	0.0	0.0	0.0	0.0
Rest In Walk		No	No		No	
I1, Start-Up Lost Time [s]	2.0	2.0	2.0	0.0	2.0	2.0
I2, Clearance Lost Time [s]	2.5	3.7	3.7	0.0	2.5	2.5
Detector Location [ft]	0.0	0.0	0.0	0.0	0.0	0.0
Detector Length [ft]	0.0	0.0	0.0	0.0	20.0	20.0
I, Upstream Filtering Factor	1.00	1.00	1.00	1.00	1.00	1.00

**Phasing & Timing: Pattern 1**

Split [s]	25	70	45	0	35	35
Lead / Lag	Lead	-	-	-	Lead	-
Minimum Green [s]	10	10	10	0	10	10
Vehicle Extension [s]	2.0	5.0	5.0	0.0	2.0	2.0
Minimum Recall	No	Yes	Yes		No	No
Maximum Recall	No	No	No		No	No
Pedestrian Recall	No	No	No		No	No

**Exclusive Pedestrian Phase**

Pedestrian Signal Group	0
Pedestrian Walk [s]	0
Pedestrian Clearance [s]	0



**Lane Group Calculations**

Lane Group	L	C	C	R	L	R
C, Cycle Length [s]	60	60	60	60	60	60
L, Total Lost Time per Cycle [s]	4.50	5.70	5.70	5.70	4.50	4.50
l1_p, Permitted Start-Up Lost Time [s]	0.00	0.00	0.00	0.00	0.00	0.00
l2, Clearance Lost Time [s]	2.50	3.70	3.70	3.70	2.50	0.00
g_i, Effective Green Time [s]	10	41	27	27	9	23
g / C, Green / Cycle	0.16	0.68	0.44	0.44	0.15	0.39
(v / s)_i Volume / Saturation Flow Rate	0.06	0.14	0.19	0.03	0.01	0.04
s, saturation flow rate [veh/h]	3467	6677	6846	1615	3514	2761
c, Capacity [veh/h]	564	4552	3040	717	520	1065
d1, Uniform Delay [s]	22.35	3.55	11.44	9.53	21.87	11.74
k, delay calibration	0.04	0.23	0.23	0.23	0.04	0.04
l, Upstream Filtering Factor	1.00	1.00	1.00	1.00	1.00	1.00
d2, Incremental Delay [s]	0.15	0.05	0.21	0.08	0.01	0.01
d3, Initial Queue Delay [s]	0.00	0.00	0.00	0.00	0.00	0.00
Rp, platoon ratio	1.00	1.00	1.00	1.00	1.00	1.00
PF, progression factor	1.00	1.00	1.00	1.00	1.00	1.00

**Lane Group Results**

X, volume / capacity	0.37	0.21	0.43	0.07	0.04	0.10
d, Delay for Lane Group [s/veh]	22.50	3.60	11.65	9.61	21.89	11.76
Lane Group LOS	C	A	B	A	C	B
Critical Lane Group	Yes	No	Yes	No	No	Yes
50th-Percentile Queue Length [veh/ln]	1.17	0.50	2.43	0.30	0.13	0.41
50th-Percentile Queue Length [ft/ln]	29.17	12.53	60.69	7.54	3.20	10.24
95th-Percentile Queue Length [veh/ln]	2.10	0.90	4.37	0.54	0.23	0.74
95th-Percentile Queue Length [ft/ln]	52.51	22.56	109.24	13.56	5.76	18.44



**Movement, Approach, & Intersection Results**

d_M, Delay for Movement [s/veh]	22.50	3.60	11.65	9.61	21.89	11.76
Movement LOS	C	A	B	A	C	B
d_A, Approach Delay [s/veh]	6.97		11.58		13.53	
Approach LOS	A		B		B	
d_I, Intersection Delay [s/veh]	9.63					
Intersection LOS	A					
Intersection V/C	0.332					

**Emissions**

Vehicle Miles Traveled [mph]	31.95	147.28	175.81	6.31	1.35	6.38
Stops [stops/h]	140.62	120.82	585.04	18.16	15.43	49.38
Fuel consumption [US gal/h]	3.81	7.26	15.15	0.50	0.22	0.73
CO [g/h]	265.98	507.39	1058.82	34.70	15.23	50.69
NOx [g/h]	51.75	98.72	206.01	6.75	2.96	9.86
VOC [g/h]	61.64	117.59	245.39	8.04	3.53	11.75

**Other Modes**

g_Walk,mi, Effective Walk Time [s]	0.0		0.0		8.0	
M_corner, Corner Circulation Area [ft <sup>2</sup> /ped]	0.00		0.00		0.00	
M_CW, Crosswalk Circulation Area [ft <sup>2</sup> /ped]	0.00		0.00		0.00	
d_p, Pedestrian Delay [s]	0.00		0.00		22.41	
I_p,int, Pedestrian LOS Score for Intersectio	0.000		0.000		2.487	
Crosswalk LOS	F		F		B	
s_b, Saturation Flow Rate of the bicycle lane	2000		2000		2000	
c_b, Capacity of the bicycle lane [bicycles/h]	2152		1315		1021	
d_b, Bicycle Delay [s]	0.17		3.50		7.16	
I_b,int, Bicycle LOS Score for Intersection	2.046		2.119		1.560	
Bicycle LOS	B		B		A	

**Sequence**

Ring 1	-	2	3	4	-	-	-	-	-	-	-	-	-	-	-	-
Ring 2	-	-	-	8	-	-	-	-	-	-	-	-	-	-	-	-
Ring 3	-	-	-	-	-	-	-	-	-	-	-	-	-	-	-	-
Ring 4	-	-	-	-	-	-	-	-	-	-	-	-	-	-	-	-



**Intersection Level Of Service Report**  
**Intersection 11: Fallon Road & I-580 WB Ramps**

Control Type:	Signalized	Delay (sec / veh):	13.5
Analysis Method:	HCM 7th Edition	Level Of Service:	B
Analysis Period:	15 minutes	Volume to Capacity (v/c):	0.710

**Intersection Setup**

Name	Fallon Road			Fallon Road			I-580 WB On-Ramp			I-580 WB Off-Ramp		
Approach	Northbound			Southbound			Eastbound			Westbound		
Lane Configuration	↑			↑↑↑						↑↑↑		
Turning Movement	Left	Thru	Right	Left	Thru	Right	Left	Thru	Right	Left	Thru	Right
Lane Width [ft]	12.00	12.00	12.00	12.00	12.00	12.00	12.00	12.00	12.00	12.00	12.00	12.00
No. of Lanes in Entry Pocket	0	0	0	0	0	1	0	0	0	1	0	1
Entry Pocket Length [ft]	100.00	100.00	100.00	100.00	100.00	225.00	100.00	100.00	100.00	170.00	100.00	130.00
No. of Lanes in Exit Pocket	0	0	1	0	0	0	0	0	1	0	0	0
Exit Pocket Length [ft]	0.00	0.00	400.00	0.00	0.00	0.00	0.00	0.00	400.00	0.00	0.00	0.00
Speed [mph]	45.00			40.00			30.00			35.00		
Grade [%]	0.00			0.00			0.00			0.00		
Curb Present	No			No						No		
Crosswalk	No			No			No			No		



**Volumes**

Name	Fallon Road			Fallon Road			I-580 WB On-Ramp			I-580 WB Off-Ramp		
Base Volume Input [veh/h]	0	747	0	0	712	700	0	0	0	222	7	471
Base Volume Adjustment Factor	1.0000	1.0000	1.0000	1.0000	1.0000	1.0000	1.0000	1.0000	1.0000	1.0000	1.0000	1.0000
Heavy Vehicles Percentage [%]	2.00	0.60	2.00	2.00	1.90	0.40	2.00	2.00	2.00	4.20	0.00	4.00
Proportion of CAVs [%]	0.00											
Growth Factor	1.0000	1.0000	1.0000	1.0000	1.0000	1.0000	1.0000	1.0000	1.0000	1.0000	1.0000	1.0000
In-Process Volume [veh/h]	0	0	0	0	0	0	0	0	0	0	0	0
Site-Generated Trips [veh/h]	0	0	0	0	0	0	0	0	0	0	0	0
Diverted Trips [veh/h]	0	0	0	0	0	0	0	0	0	0	0	0
Pass-by Trips [veh/h]	0	0	0	0	0	0	0	0	0	0	0	0
Existing Site Adjustment Volume [veh/h]	0	0	0	0	0	0	0	0	0	0	0	0
Other Volume [veh/h]	0	0	0	0	0	0	0	0	0	0	0	0
Right Turn on Red Volume [veh/h]	0	0	0	0	0	0	0	0	0	0	0	0
Total Hourly Volume [veh/h]	0	747	0	0	712	700	0	0	0	222	7	471
Peak Hour Factor	1.0000	0.9500	1.0000	1.0000	0.9500	0.9500	1.0000	1.0000	1.0000	0.9500	0.9500	0.9500
Other Adjustment Factor	1.0000	1.0000	1.0000	1.0000	1.0000	1.0000	1.0000	1.0000	1.0000	1.0000	1.0000	1.0000
Total 15-Minute Volume [veh/h]	0	197	0	0	187	184	0	0	0	58	2	124
Total Analysis Volume [veh/h]	0	786	0	0	749	737	0	0	0	234	7	496
Presence of On-Street Parking	No		No	No		No				No		No
On-Street Parking Maneuver Rate [/h]	0	0	0	0	0	0	0	0	0	0	0	0
Local Bus Stopping Rate [/h]	0	0	0	0	0	0	0	0	0	0	0	0
v_do, Outbound Pedestrian Volume crossing	0			0			0			0		
v_di, Inbound Pedestrian Volume crossing m	0			0			0			0		
v_co, Outbound Pedestrian Volume crossing	0			0			0			0		
v_ci, Inbound Pedestrian Volume crossing mi	0			0			0			0		
v_ab, Corner Pedestrian Volume [ped/h]	0			0			0			0		
Bicycle Volume [bicycles/h]	0			0			0			0		



**Intersection Settings**

Located in CBD	No
Signal Coordination Group	-
Cycle Length [s]	90
Active Pattern	Free Running (No Pattern)
Coordination Type	<i>Free Running</i>
Actuation Type	<i>Fully actuated</i>
Offset [s]	0.0
Offset Reference	Lead Green - Beginning of First Green
Permissive Mode	SingleBand
Lost time [s]	9.00

**Phasing & Timing (Basic)**

Control Type	Permiss	Permiss	Permiss	Permiss	Permiss	Permiss	Permiss	Permiss	Permiss	Permiss	Permiss	Overlap
Signal Group	0	2	0	0	6	0	0	0	0	0	8	1
Auxiliary Signal Groups												1,8
Maximum Green [s]	0	35	0	0	35	0	0	0	0	0	20	15
Amber [s]	0.0	4.8	0.0	0.0	4.8	0.0	0.0	0.0	0.0	0.0	3.7	3.7
All red [s]	0.0	0.5	0.0	0.0	0.5	0.0	0.0	0.0	0.0	0.0	0.5	0.5
Walk [s]	0	0	0	0	0	0	0	0	0	0	0	0
Pedestrian Clearance [s]	0	0	0	0	0	0	0	0	0	0	0	0
Delayed Vehicle Green [s]	0.0	0.0	0.0	0.0	0.0	0.0	0.0	0.0	0.0	0.0	0.0	0.0
Rest In Walk		No			No						No	
I1, Start-Up Lost Time [s]	0.0	2.0	0.0	0.0	2.0	0.0	0.0	0.0	0.0	0.0	2.0	2.0
I2, Clearance Lost Time [s]	0.0	3.3	0.0	0.0	3.3	0.0	0.0	0.0	0.0	0.0	2.2	2.2
Detector Location [ft]	0.0	0.0	0.0	0.0	0.0	0.0	0.0	0.0	0.0	0.0	0.0	0.0
Detector Length [ft]	0.0	20.0	0.0	0.0	20.0	0.0	0.0	0.0	0.0	0.0	20.0	20.0
I, Upstream Filtering Factor	1.00	1.00	1.00	1.00	1.00	1.00	1.00	1.00	1.00	1.00	1.00	1.00

**Phasing & Timing: Free Running (No Pattern)**

Split [s]	0	0	0	0	0	0	0	0	0	0	0	0
Lead / Lag	-	-	-	-	-	-	-	-	-	-	-	-
Minimum Green [s]	0	10	0	0	10	0	0	0	0	0	5	4
Vehicle Extension [s]	0.0	0.0	0.0	0.0	0.0	0.0	0.0	0.0	0.0	0.0	0.0	0.0
Minimum Recall		Yes			Yes						No	No
Maximum Recall		No			No						No	No
Pedestrian Recall		No			No						No	No

**Exclusive Pedestrian Phase**

Pedestrian Signal Group	0
Pedestrian Walk [s]	0
Pedestrian Clearance [s]	0



**Lane Group Calculations**

Lane Group	C	C	R		L	C	R
C, Cycle Length [s]	59	59	59		59	59	59
L, Total Lost Time per Cycle [s]	5.30	5.30	5.30		4.20	4.20	4.20
l1_p, Permitted Start-Up Lost Time [s]	0.00	0.00	0.00		0.00	0.00	0.00
l2, Clearance Lost Time [s]	3.30	3.30	3.30		2.20	2.20	0.00
g_i, Effective Green Time [s]	26	40	40		10	10	24
g / C, Green / Cycle	0.44	0.67	0.67		0.17	0.17	0.40
(v / s)_i Volume / Saturation Flow Rate	0.42	0.21	0.46		0.07	0.07	0.18
s, saturation flow rate [veh/h]	1891	3563	1610		1749	1814	2768
c, Capacity [veh/h]	826	2399	1084		289	300	1113
d1, Uniform Delay [s]	15.99	3.98	5.80		22.00	22.00	12.83
k, delay calibration	0.17	0.04	0.23		0.04	0.04	0.04
l, Upstream Filtering Factor	1.00	1.00	1.00		1.00	1.00	1.00
d2, Incremental Delay [s]	9.93	0.03	1.59		0.34	0.33	0.10
d3, Initial Queue Delay [s]	0.00	0.00	0.00		0.00	0.00	0.00
Rp, platoon ratio	1.00	1.00	1.00		1.00	1.00	1.00
PF, progression factor	1.00	1.00	1.00		1.00	1.00	1.00

**Lane Group Results**

X, volume / capacity	0.95	0.31	0.68		0.41	0.41	0.45
d, Delay for Lane Group [s/veh]	25.93	4.01	7.38		22.34	22.33	12.93
Lane Group LOS	C	A	A		C	C	B
Critical Lane Group	No	No	Yes		No	No	Yes
50th-Percentile Queue Length [veh/ln]	9.86	0.96	3.20		1.36	1.41	2.03
50th-Percentile Queue Length [ft/ln]	246.52	23.94	79.92		34.07	35.28	50.66
95th-Percentile Queue Length [veh/ln]	15.01	1.72	5.75		2.45	2.54	3.65
95th-Percentile Queue Length [ft/ln]	375.27	43.09	143.85		61.33	63.51	91.20

**Movement, Approach, & Intersection Results**

d_M, Delay for Movement [s/veh]	0.00	25.93	0.00	0.00	4.01	7.38	0.00	0.00	0.00	22.33	22.33	12.93
Movement LOS		C			A	A				C	C	B
d_A, Approach Delay [s/veh]	25.93		5.68			0.00			16.01			
Approach LOS	C		A			A			B			
d_I, Intersection Delay [s/veh]	13.50											
Intersection LOS	B											
Intersection V/C	0.710											

**Emissions**

Vehicle Miles Traveled [mph]	81.92	113.96	112.13	17.17	17.79	71.95
Stops [stops/h]	603.92	117.28	195.78	83.46	86.43	248.23
Fuel consumption [US gal/h]	14.46	5.84	7.05	1.82	1.89	5.91
CO [g/h]	1011.01	408.55	492.62	127.23	131.80	413.45
NOx [g/h]	196.71	79.49	95.85	24.75	25.64	80.44
VOC [g/h]	234.31	94.69	114.17	29.49	30.55	95.82

**Other Modes**

g_Walk,mi, Effective Walk Time [s]	0.0	0.0	0.0	0.0
M_corner, Corner Circulation Area [ft <sup>2</sup> /ped]	0.00	0.00	0.00	0.00
M_CW, Crosswalk Circulation Area [ft <sup>2</sup> /ped]	0.00	0.00	0.00	0.00
d_p, Pedestrian Delay [s]	0.00	0.00	0.00	0.00
I_p,int, Pedestrian LOS Score for Intersectio	0.000	0.000	0.000	0.000
Crosswalk LOS	F	F	F	F
s_b, Saturation Flow Rate of the bicycle lane	2000	2000	2000	2000
c_b, Capacity of the bicycle lane [bicycles/h]	1191	1191	0	680
d_b, Bicycle Delay [s]	4.81	4.81	29.39	12.79
I_b,int, Bicycle LOS Score for Intersection	2.857	2.786	4.132	2.776
Bicycle LOS	C	C	D	C

**Sequence**

Ring 1	1	2	-	-	-	-	-	-	-	-	-	-	-	-	-
Ring 2	-	6	-	8	-	-	-	-	-	-	-	-	-	-	-
Ring 3	-	-	-	-	-	-	-	-	-	-	-	-	-	-	-
Ring 4	-	-	-	-	-	-	-	-	-	-	-	-	-	-	-



**Intersection Level Of Service Report**  
**Intersection 12: El Charro Road & I-580 EB Ramps**

Control Type:	Signalized	Delay (sec / veh):	7.5
Analysis Method:	HCM 7th Edition	Level Of Service:	A
Analysis Period:	15 minutes	Volume to Capacity (v/c):	0.687

**Intersection Setup**

Name	El Charro Road			Fallon Road			I-580 EB Off-Ramp			I-580 EB On-Ramp		
Approach	Northbound			Southbound			Eastbound			Westbound		
Lane Configuration	↑↑			↑↑			↵↵↵↵					
Turning Movement	Left	Thru	Right	Left	Thru	Right	Left	Thru	Right	Left	Thru	Right
Lane Width [ft]	12.00	12.00	12.00	12.00	12.00	12.00	12.00	12.00	12.00	12.00	12.00	12.00
No. of Lanes in Entry Pocket	0	0	0	1	0	0	1	0	1	0	0	0
Entry Pocket Length [ft]	100.00	100.00	100.00	135.00	100.00	100.00	350.00	100.00	350.00	100.00	100.00	100.00
No. of Lanes in Exit Pocket	0	0	0	0	0	1	0	0	0	0	0	0
Exit Pocket Length [ft]	0.00	0.00	0.00	0.00	0.00	100.00	0.00	0.00	0.00	0.00	0.00	0.00
Speed [mph]	30.00			40.00			35.00			30.00		
Grade [%]	0.00			0.00			0.00			0.00		
Curb Present	No			No			No					
Crosswalk	No			No			No			Yes		



**Volumes**

Name	El Charro Road			Fallon Road			I-580 EB Off-Ramp			I-580 EB On-Ramp		
Base Volume Input [veh/h]	0	891	0	0	512	0	327	0	392	0	0	0
Base Volume Adjustment Factor	1.0000	1.0000	1.0000	1.0000	1.0000	1.0000	1.0000	1.0000	1.0000	1.0000	1.0000	1.0000
Heavy Vehicles Percentage [%]	2.00	10.40	2.00	2.00	2.70	2.00	0.90	2.00	10.60	2.00	2.00	2.00
Proportion of CAVs [%]	0.00											
Growth Factor	1.0000	1.0000	1.0000	1.0000	1.0000	1.0000	1.0000	1.0000	1.0000	1.0000	1.0000	1.0000
In-Process Volume [veh/h]	0	0	0	0	0	0	0	0	0	0	0	0
Site-Generated Trips [veh/h]	0	0	0	0	0	0	0	0	0	0	0	0
Diverted Trips [veh/h]	0	0	0	0	0	0	0	0	0	0	0	0
Pass-by Trips [veh/h]	0	0	0	0	0	0	0	0	0	0	0	0
Existing Site Adjustment Volume [veh/h]	0	0	0	0	0	0	0	0	0	0	0	0
Other Volume [veh/h]	0	0	0	0	0	0	0	0	0	0	0	0
Right Turn on Red Volume [veh/h]	0	0	0	0	0	0	0	0	0	0	0	0
Total Hourly Volume [veh/h]	0	891	0	0	512	0	327	0	392	0	0	0
Peak Hour Factor	1.0000	0.9300	1.0000	1.0000	0.9300	1.0000	0.9300	1.0000	0.9300	1.0000	1.0000	1.0000
Other Adjustment Factor	1.0000	1.0000	1.0000	1.0000	1.0000	1.0000	1.0000	1.0000	1.0000	1.0000	1.0000	1.0000
Total 15-Minute Volume [veh/h]	0	240	0	0	138	0	88	0	105	0	0	0
Total Analysis Volume [veh/h]	0	958	0	0	551	0	352	0	422	0	0	0
Presence of On-Street Parking	No		No	No		No	No		No			
On-Street Parking Maneuver Rate [/h]	0	0	0	0	0	0	0	0	0	0	0	0
Local Bus Stopping Rate [/h]	0	0	0	0	0	0	0	0	0	0	0	0
v_do, Outbound Pedestrian Volume crossing	0			0			0			0		
v_di, Inbound Pedestrian Volume crossing m	0			0			0			0		
v_co, Outbound Pedestrian Volume crossing	0			0			0			0		
v_ci, Inbound Pedestrian Volume crossing mi	0			0			0			0		
v_ab, Corner Pedestrian Volume [ped/h]	0			0			0			0		
Bicycle Volume [bicycles/h]	0			0			0			0		





**Intersection Settings**

Located in CBD	No
Signal Coordination Group	-
Cycle Length [s]	90
Active Pattern	Free Running (No Pattern)
Coordination Type	<i>Free Running</i>
Actuation Type	<i>Fully actuated</i>
Offset [s]	0.0
Offset Reference	Lead Green - Beginning of First Green
Permissive Mode	SingleBand
Lost time [s]	9.00

**Phasing & Timing (Basic)**

Control Type	Permiss	Permiss	Permiss	Permiss	Permiss	Permiss	Permiss	Permiss	Permiss	Permiss	Permiss	Permiss
Signal Group	0	2	0	0	6	0	4	0	0	0	0	0
Auxiliary Signal Groups												
Maximum Green [s]	0	40	0	0	40	0	26	0	0	0	0	0
Amber [s]	0.0	4.8	0.0	0.0	4.8	0.0	3.7	0.0	0.0	0.0	0.0	0.0
All red [s]	0.0	1.0	0.0	0.0	1.0	0.0	0.5	0.0	0.0	0.0	0.0	0.0
Walk [s]	0	0	0	0	0	0	0	0	0	0	0	0
Pedestrian Clearance [s]	0	0	0	0	0	0	0	0	0	0	0	0
Delayed Vehicle Green [s]	0.0	0.0	0.0	0.0	0.0	0.0	0.0	0.0	0.0	0.0	0.0	0.0
Rest In Walk		No			No		No					
I1, Start-Up Lost Time [s]	0.0	2.0	0.0	0.0	2.0	0.0	2.0	0.0	0.0	0.0	0.0	0.0
I2, Clearance Lost Time [s]	0.0	3.3	0.0	0.0	3.3	0.0	2.7	0.0	0.0	0.0	0.0	0.0
Detector Location [ft]	0.0	0.0	0.0	0.0	0.0	0.0	0.0	0.0	0.0	0.0	0.0	0.0
Detector Length [ft]	0.0	20.0	0.0	0.0	20.0	0.0	20.0	0.0	0.0	0.0	0.0	0.0
I, Upstream Filtering Factor	1.00	1.00	1.00	1.00	1.00	1.00	1.00	1.00	1.00	1.00	1.00	1.00

**Phasing & Timing: Free Running (No Pattern)**

Split [s]	0	0	0	0	0	0	0	0	0	0	0	0
Lead / Lag	-	-	-	-	-	-	Lead	-	-	-	-	-
Minimum Green [s]	0	10	0	0	10	0	4	0	0	0	0	0
Vehicle Extension [s]	0.0	0.0	0.0	0.0	0.0	0.0	0.0	0.0	0.0	0.0	0.0	0.0
Minimum Recall		Yes			Yes		No					
Maximum Recall		No			No		No					
Pedestrian Recall		No			No		No					

**Exclusive Pedestrian Phase**

Pedestrian Signal Group	0
Pedestrian Walk [s]	0
Pedestrian Clearance [s]	0



**Lane Group Calculations**

Lane Group	C	C	L	R	
C, Cycle Length [s]	26	26	26	26	
L, Total Lost Time per Cycle [s]	5.30	5.30	4.70	4.70	
l1_p, Permitted Start-Up Lost Time [s]	0.00	0.00	0.00	0.00	
l2, Clearance Lost Time [s]	3.30	3.30	2.70	2.70	
g_i, Effective Green Time [s]	11	11	6	6	
g / C, Green / Cycle	0.40	0.40	0.21	0.21	
(v / s)_i Volume / Saturation Flow Rate	0.29	0.16	0.10	0.16	
s, saturation flow rate [veh/h]	3320	3540	3489	2619	
c, Capacity [veh/h]	1341	1430	744	559	
d1, Uniform Delay [s]	6.52	5.50	8.99	9.64	
k, delay calibration	0.04	0.04	0.04	0.04	
l, Upstream Filtering Factor	1.00	1.00	1.00	1.00	
d2, Incremental Delay [s]	0.27	0.06	0.17	0.79	
d3, Initial Queue Delay [s]	0.00	0.00	0.00	0.00	
Rp, platoon ratio	1.00	1.00	1.00	1.00	
PF, progression factor	1.00	1.00	1.00	1.00	

**Lane Group Results**

X, volume / capacity	0.71	0.39	0.47	0.76	
d, Delay for Lane Group [s/veh]	6.79	5.56	9.17	10.43	
Lane Group LOS	A	A	A	B	
Critical Lane Group	Yes	No	No	Yes	
50th-Percentile Queue Length [veh/ln]	1.01	0.33	0.52	0.71	
50th-Percentile Queue Length [ft/ln]	25.24	8.24	13.12	17.82	
95th-Percentile Queue Length [veh/ln]	1.82	0.59	0.94	1.28	
95th-Percentile Queue Length [ft/ln]	45.43	14.83	23.62	32.07	

**Movement, Approach, & Intersection Results**

d_M, Delay for Movement [s/veh]	0.00	6.79	0.00	0.00	5.56	0.00	9.17	0.00	10.43	0.00	0.00	0.00
Movement LOS		A			A		A		B			
d_A, Approach Delay [s/veh]	6.79			5.56			9.85			0.00		
Approach LOS	A			A			A			A		
d_I, Intersection Delay [s/veh]	7.53											
Intersection LOS	A											
Intersection V/C	0.687											

**Emissions**

Vehicle Miles Traveled [mph]	164.92	54.12	40.90	49.03
Stops [stops/h]	279.17	91.15	145.15	197.08
Fuel consumption [US gal/h]	9.66	3.46	3.31	4.25
CO [g/h]	674.94	241.67	231.18	296.85
NOx [g/h]	131.32	47.02	44.98	57.76
VOC [g/h]	156.42	56.01	53.58	68.80

**Other Modes**

g_Walk,mi, Effective Walk Time [s]	0.0	0.0	0.0	-5.8
M_corner, Corner Circulation Area [ft <sup>2</sup> /ped]	0.00	0.00	0.00	0.00
M_CW, Crosswalk Circulation Area [ft <sup>2</sup> /ped]	0.00	0.00	0.00	0.00
d_p, Pedestrian Delay [s]	0.00	0.00	0.00	19.46
I_p,int, Pedestrian LOS Score for Intersectio	0.000	0.000	0.000	1.691
Crosswalk LOS	F	F	F	A
s_b, Saturation Flow Rate of the bicycle lane	2000	2000	2000	2000
c_b, Capacity of the bicycle lane [bicycles/h]	3073	3073	1997	0
d_b, Bicycle Delay [s]	3.74	3.74	0.00	13.02
I_b,int, Bicycle LOS Score for Intersection	2.350	2.014	1.560	4.132
Bicycle LOS	B	B	A	D

**Sequence**

Ring 1	-	2	-	4	-	-	-	-	-	-	-	-	-	-	-	-
Ring 2	-	6	-	-	-	-	-	-	-	-	-	-	-	-	-	-
Ring 3	-	-	-	-	-	-	-	-	-	-	-	-	-	-	-	-
Ring 4	-	-	-	-	-	-	-	-	-	-	-	-	-	-	-	-



**Intersection Level Of Service Report**  
**Intersection 13: El Charro Road & Jack London Boulevard**

Control Type:	Signalized	Delay (sec / veh):	41.7
Analysis Method:	HCM 7th Edition	Level Of Service:	D
Analysis Period:	15 minutes	Volume to Capacity (v/c):	0.748

**Intersection Setup**

Name	El Charro Road			El Charro Road			Stoneridge Drive			Jack London Boulevard		
Approach	Northbound			Southbound			Eastbound			Westbound		
Lane Configuration	T T T			T T T			T T T			T T T		
Turning Movement	Left	Thru	Right	Left	Thru	Right	Left	Thru	Right	Left	Thru	Right
Lane Width [ft]	12.00	12.00	12.00	12.00	12.00	12.00	12.00	12.00	12.00	12.00	12.00	12.00
No. of Lanes in Entry Pocket	1	0	2	2	0	1	3	0	1	1	0	2
Entry Pocket Length [ft]	125.00	100.00	175.00	650.00	100.00	450.00	450.00	100.00	325.00	400.00	100.00	775.00
No. of Lanes in Exit Pocket	0	0	0	0	0	1	1	0	0	0	0	0
Exit Pocket Length [ft]	0.00	0.00	0.00	0.00	0.00	49.21	450.00	0.00	0.00	0.00	0.00	0.00
Speed [mph]	30.00			30.00			30.00			30.00		
Grade [%]	0.00			0.00			0.00			0.00		
Curb Present	Yes			Yes			Yes			Yes		
Crosswalk	Yes			No			Yes			Yes		



**Volumes**

Name	El Charro Road			El Charro Road			Stoneridge Drive			Jack London Boulevard		
Base Volume Input [veh/h]	81	433	23	239	204	500	244	80	23	101	775	622
Base Volume Adjustment Factor	1.0000	1.0000	1.0000	1.0000	1.0000	1.0000	1.0000	1.0000	1.0000	1.0000	1.0000	1.0000
Heavy Vehicles Percentage [%]	0.00	86.00	33.30	0.40	66.70	0.20	2.30	5.30	0.00	37.50	1.20	1.10
Proportion of CAVs [%]	0.00											
Growth Factor	1.0000	1.0000	1.0000	1.0000	1.0000	1.0000	1.0000	1.0000	1.0000	1.0000	1.0000	1.0000
In-Process Volume [veh/h]	0	0	0	0	0	0	0	0	0	0	0	0
Site-Generated Trips [veh/h]	0	0	0	0	0	0	0	0	0	0	0	0
Diverted Trips [veh/h]	0	0	0	0	0	0	0	0	0	0	0	0
Pass-by Trips [veh/h]	0	0	0	0	0	0	0	0	0	0	0	0
Existing Site Adjustment Volume [veh/h]	0	0	0	0	0	0	0	0	0	0	0	0
Other Volume [veh/h]	0	0	0	0	0	0	0	0	0	0	0	0
Right Turn on Red Volume [veh/h]	0	0	0	0	0	0	0	0	0	0	0	0
Total Hourly Volume [veh/h]	81	433	23	239	204	500	244	80	23	101	775	622
Peak Hour Factor	0.8900	0.8900	0.8900	0.8900	0.8900	0.8900	0.8900	0.8900	0.8900	0.8900	0.8900	0.8900
Other Adjustment Factor	1.0000	1.0000	1.0000	1.0000	1.0000	1.0000	1.0000	1.0000	1.0000	1.0000	1.0000	1.0000
Total 15-Minute Volume [veh/h]	23	122	6	67	57	140	69	22	6	28	218	175
Total Analysis Volume [veh/h]	91	487	26	269	229	562	274	90	26	113	871	699
Presence of On-Street Parking	No		No	No		No	No		No	No		No
On-Street Parking Maneuver Rate [/h]	0	0	0	0	0	0	0	0	0	0	0	0
Local Bus Stopping Rate [/h]	0	0	0	0	0	0	0	0	0	0	0	0
v_do, Outbound Pedestrian Volume crossing	0			0			0			0		
v_di, Inbound Pedestrian Volume crossing m	0			0			0			0		
v_co, Outbound Pedestrian Volume crossing	0			0			0			1		
v_ci, Inbound Pedestrian Volume crossing mi	1			0			0			0		
v_ab, Corner Pedestrian Volume [ped/h]	0			0			0			0		
Bicycle Volume [bicycles/h]	0			0			1			0		



**Intersection Settings**

Located in CBD	No
Signal Coordination Group	-
Cycle Length [s]	90
Active Pattern	Free Running (No Pattern)
Coordination Type	Free Running
Actuation Type	Fully actuated
Offset [s]	0.0
Offset Reference	Lead Green - Beginning of First Green
Permissive Mode	SingleBand
Lost time [s]	12.00

**Phasing & Timing (Basic)**

Control Type	Protecte	Permiss	Permiss	Protecte	Permiss	Unsigna	Protecte	Permiss	Permiss	Protecte	Permiss	Overlap
Signal Group	7	4	0	3	8	0	1	6	0	5	2	2
Auxiliary Signal Groups												2,3
Maximum Green [s]	13	25	0	35	20	0	20	25	0	15	20	20
Amber [s]	3.0	5.0	0.0	3.0	4.3	0.0	3.0	4.3	0.0	3.0	4.3	4.3
All red [s]	1.0	1.0	0.0	1.0	1.0	0.0	1.0	1.0	0.0	1.0	1.0	1.0
Walk [s]	0	5	0	0	5	0	0	5	0	0	0	0
Pedestrian Clearance [s]	0	28	0	0	28	0	0	30	0	0	0	0
Delayed Vehicle Green [s]	0.0	0.0	0.0	0.0	0.0	0.0	0.0	0.0	0.0	0.0	0.0	0.0
Rest In Walk		No			No			No			No	
I1, Start-Up Lost Time [s]	2.0	2.0	0.0	2.0	2.0	0.0	2.0	2.0	0.0	2.0	2.0	2.0
I2, Clearance Lost Time [s]	2.0	2.0	0.0	2.0	2.0	0.0	2.0	2.0	0.0	2.0	2.0	2.0
Detector Location [ft]	0.0	0.0	0.0	0.0	0.0	0.0	0.0	0.0	0.0	0.0	0.0	0.0
Detector Length [ft]	20.0	20.0	0.0	20.0	20.0	0.0	20.0	20.0	0.0	0.0	0.0	0.0
I, Upstream Filtering Factor	1.00	1.00	1.00	1.00	1.00	1.00	1.00	1.00	1.00	1.00	1.00	1.00

**Phasing & Timing: Free Running (No Pattern)**

Split [s]	0	0	0	0	0	0	0	0	0	0	0	0
Lead / Lag	Lead	-	-	Lead	-	-	Lead	-	-	Lead	-	-
Minimum Green [s]	4	5	0	7	5	0	5	4	0	4	7	7
Vehicle Extension [s]	2.0	2.5	0.0	2.5	2.5	0.0	2.0	3.0	0.0	2.0	3.0	3.0
Minimum Recall	No	No		No	No		No	Yes		No	Yes	Yes
Maximum Recall	No	No		No	No		No	No		No	No	No
Pedestrian Recall	No	No		No	No		No	No		No	No	No

**Exclusive Pedestrian Phase**

Pedestrian Signal Group	0
Pedestrian Walk [s]	0
Pedestrian Clearance [s]	0



**Lane Group Calculations**

Lane Group	L	C	C	L	C	L	C	R	L	C	R
C, Cycle Length [s]	92	92	92	92	92	92	92	92	92	92	92
L, Total Lost Time per Cycle [s]	4.00	4.00	4.00	4.00	4.00	4.00	4.00	4.00	4.00	4.00	4.00
l1_p, Permitted Start-Up Lost Time [s]	0.00	0.00	0.00	0.00	0.00	0.00	0.00	0.00	0.00	0.00	0.00
l2, Clearance Lost Time [s]	2.00	2.00	2.00	2.00	2.00	2.00	2.00	2.00	2.00	2.00	0.00
g_i, Effective Green Time [s]	6	27	27	20	41	7	19	19	10	21	45
g / C, Green / Cycle	0.07	0.29	0.29	0.22	0.45	0.08	0.21	0.21	0.10	0.23	0.50
(v / s)_i Volume / Saturation Flow Rate	0.05	0.29	0.29	0.05	0.25	0.05	0.03	0.02	0.09	0.24	0.25
s, saturation flow rate [veh/h]	1810	1160	593	5254	899	5175	3466	1580	1273	3583	2834
c, Capacity [veh/h]	118	341	175	1157	404	408	717	327	133	832	1405
d1, Uniform Delay [s]	42.19	32.24	32.36	29.40	18.67	41.09	29.62	29.32	40.39	35.21	15.47
k, delay calibration	0.04	0.08	0.50	0.08	0.50	0.04	0.11	0.11	0.04	0.11	0.12
l, Upstream Filtering Factor	1.00	1.00	1.00	1.00	1.00	1.00	1.00	1.00	1.00	1.00	1.00
d2, Incremental Delay [s]	3.94	17.50	68.09	0.08	5.68	0.72	0.08	0.10	5.77	29.01	0.30
d3, Initial Queue Delay [s]	0.00	0.00	0.00	0.00	0.00	0.00	0.00	0.00	0.00	0.00	0.00
Rp, platoon ratio	1.00	1.00	1.00	1.00	1.00	1.00	1.00	1.00	1.00	1.00	1.00
PF, progression factor	1.00	1.00	1.00	1.00	1.00	1.00	1.00	1.00	1.00	1.00	1.00

**Lane Group Results**

X, volume / capacity	0.77	0.99	1.00	0.23	0.57	0.67	0.13	0.08	0.85	1.05	0.50
d, Delay for Lane Group [s/veh]	46.13	49.74	100.46	29.47	24.35	41.81	29.69	29.42	46.16	64.23	15.77
Lane Group LOS	D	D	F	C	C	D	C	C	D	F	B
Critical Lane Group	No	No	Yes	No	No	Yes	No	No	No	Yes	Yes
50th-Percentile Queue Length [veh/ln]	2.13	4.43	7.03	1.61	4.06	2.01	0.81	0.47	2.68	12.38	4.68
50th-Percentile Queue Length [ft/ln]	53.33	110.74	175.87	40.32	101.47	50.27	20.17	11.66	67.10	309.45	116.89
95th-Percentile Queue Length [veh/ln]	3.84	7.88	11.38	2.90	7.31	3.62	1.45	0.84	4.83	18.61	8.22
95th-Percentile Queue Length [ft/ln]	96.00	197.03	284.62	72.57	182.64	90.49	36.31	20.99	120.77	465.23	205.55



**Movement, Approach, & Intersection Results**

d_M, Delay for Movement [s/veh]	46.13	65.23	100.46	29.47	24.35	0.00	41.81	29.69	29.42	46.16	64.23	15.77
Movement LOS	D	E	F	C	C		D	C	C	D	F	B
d_A, Approach Delay [s/veh]	63.87			13.53			38.19			42.89		
Approach LOS	E			B			D			D		
d_I, Intersection Delay [s/veh]	41.70											
Intersection LOS	D											
Intersection V/C	0.748											

**Emissions**

Vehicle Miles Traveled [mph]	5.78	21.47	11.09	46.31	39.42	29.34	9.64	2.78	19.63	151.32	121.44
Stops [stops/h]	83.81	348.00	276.36	190.05	159.43	236.99	63.39	18.32	105.43	972.47	367.34
Fuel consumption [US gal/h]	1.55	6.23	5.55	4.57	3.64	4.85	1.29	0.37	2.45	22.99	9.27
CO [g/h]	108.69	435.56	388.20	319.42	254.33	338.89	90.22	25.97	171.41	1606.65	648.10
NOx [g/h]	21.15	84.74	75.53	62.15	49.48	65.94	17.55	5.05	33.35	312.60	126.10
VOC [g/h]	25.19	100.94	89.97	74.03	58.94	78.54	20.91	6.02	39.72	372.36	150.20

**Other Modes**

g_Walk,mi, Effective Walk Time [s]	9.0	0.0	9.0	9.0
M_corner, Corner Circulation Area [ft <sup>2</sup> /ped]	0.00	0.00	0.00	0.00
M_CW, Crosswalk Circulation Area [ft <sup>2</sup> /ped]	0.00	0.00	0.00	0.00
d_p, Pedestrian Delay [s]	37.26	0.00	37.26	37.26
I_p,int, Pedestrian LOS Score for Intersectio	2.492	0.000	2.998	2.980
Crosswalk LOS	B	F	C	C
s_b, Saturation Flow Rate of the bicycle lane	2000	2000	2000	2000
c_b, Capacity of the bicycle lane [bicycles/h]	546	436	546	436
d_b, Bicycle Delay [s]	24.23	28.00	24.24	28.00
I_b,int, Bicycle LOS Score for Intersection	1.892	2.381	1.881	2.948
Bicycle LOS	A	B	A	C

**Sequence**

Ring 1	1	2	3	4	-	-	-	-	-	-	-	-	-	-	-
Ring 2	5	6	7	8	-	-	-	-	-	-	-	-	-	-	-
Ring 3	-	-	-	-	-	-	-	-	-	-	-	-	-	-	-
Ring 4	-	-	-	-	-	-	-	-	-	-	-	-	-	-	-





**Intersection Level Of Service Report**  
**Intersection 14: Central Parkway & Sunset View Drive**

Control Type:	Signalized	Delay (sec / veh):	33.4
Analysis Method:	HCM 7th Edition	Level Of Service:	C
Analysis Period:	15 minutes	Volume to Capacity (v/c):	0.786

**Intersection Setup**

Name	Driveway			Sunset View Drive			Central Parkway			Central Parkway		
Approach	Northbound			Southbound			Eastbound			Westbound		
Lane Configuration	↵↵			↵↵			↵↵↵			↵↵		
Turning Movement	Left	Thru	Right	Left	Thru	Right	Left	Thru	Right	Left	Thru	Right
Lane Width [ft]	12.00	12.00	12.00	12.00	12.00	12.00	12.00	12.00	12.00	12.00	12.00	12.00
No. of Lanes in Entry Pocket	1	0	0	0	0	1	1	0	1	1	0	0
Entry Pocket Length [ft]	250.00	100.00	100.00	100.00	100.00	85.00	225.00	100.00	800.00	150.00	100.00	100.00
No. of Lanes in Exit Pocket	0	0	0	0	0	0	0	0	0	0	0	0
Exit Pocket Length [ft]	0.00	0.00	0.00	0.00	0.00	0.00	0.00	0.00	0.00	0.00	0.00	0.00
Speed [mph]	30.00			30.00			30.00			30.00		
Grade [%]	0.00			0.00			0.00			0.00		
Curb Present	No			No			No			No		
Crosswalk	Yes			Yes			Yes			Yes		



**Volumes**

Name	Driveway			Sunset View Drive			Central Parkway			Central Parkway		
Base Volume Input [veh/h]	160	19	12	17	17	149	40	173	171	19	232	2
Base Volume Adjustment Factor	1.0000	1.0000	1.0000	1.0000	1.0000	1.0000	1.0000	1.0000	1.0000	1.0000	1.0000	1.0000
Heavy Vehicles Percentage [%]	0.70	0.00	0.00	0.00	0.00	2.00	2.50	1.70	0.00	0.00	0.40	0.00
Proportion of CAVs [%]	0.00											
Growth Factor	1.0000	1.0000	1.0000	1.0000	1.0000	1.0000	1.0000	1.0000	1.0000	1.0000	1.0000	1.0000
In-Process Volume [veh/h]	0	0	0	0	0	0	0	0	0	0	0	0
Site-Generated Trips [veh/h]	0	0	0	0	0	0	0	0	0	0	0	0
Diverted Trips [veh/h]	0	0	0	0	0	0	0	0	0	0	0	0
Pass-by Trips [veh/h]	0	0	0	0	0	0	0	0	0	0	0	0
Existing Site Adjustment Volume [veh/h]	0	0	0	0	0	0	0	0	0	0	0	0
Other Volume [veh/h]	0	0	0	0	0	0	0	0	0	0	0	0
Right Turn on Red Volume [veh/h]	0	0	0	0	0	0	0	0	0	0	0	0
Total Hourly Volume [veh/h]	160	19	12	17	17	149	40	173	171	19	232	2
Peak Hour Factor	0.5500	0.5500	0.5500	0.5500	0.5500	0.5500	0.5500	0.5500	0.5500	0.5500	0.5500	0.5500
Other Adjustment Factor	1.0000	1.0000	1.0000	1.0000	1.0000	1.0000	1.0000	1.0000	1.0000	1.0000	1.0000	1.0000
Total 15-Minute Volume [veh/h]	73	9	5	8	8	68	18	79	78	9	105	1
Total Analysis Volume [veh/h]	291	35	22	31	31	271	73	315	311	35	422	4
Presence of On-Street Parking	No		No	No		No	No		No	No		No
On-Street Parking Maneuver Rate [/h]	0	0	0	0	0	0	0	0	0	0	0	0
Local Bus Stopping Rate [/h]	0	0	0	0	0	0	0	0	0	0	0	0
v_do, Outbound Pedestrian Volume crossing	74			14			74			14		
v_di, Inbound Pedestrian Volume crossing m	74			14			74			14		
v_co, Outbound Pedestrian Volume crossing	123			37			37			124		
v_ci, Inbound Pedestrian Volume crossing mi	124			37			37			123		
v_ab, Corner Pedestrian Volume [ped/h]	0			0			0			0		
Bicycle Volume [bicycles/h]	2			0			11			0		



**Intersection Settings**

Located in CBD	No
Signal Coordination Group	-
Cycle Length [s]	90
Active Pattern	Free Running (No Pattern)
Coordination Type	<i>Free Running</i>
Actuation Type	<i>Fully actuated</i>
Offset [s]	0.0
Offset Reference	Lead Green - Beginning of First Green
Permissive Mode	SingleBand
Lost time [s]	12.00

**Phasing & Timing (Basic)**

Control Type	Protecte	Permiss	Permiss	Protecte	Permiss	Permiss	Protecte	Permiss	Permiss	Protecte	Permiss	Permiss
Signal Group	3	8	0	7	4	0	5	2	0	1	6	0
Auxiliary Signal Groups												
Maximum Green [s]	30	30	0	20	20	0	20	25	0	20	25	0
Amber [s]	3.0	3.0	0.0	3.0	3.0	0.0	3.0	3.6	0.0	3.0	3.6	0.0
All red [s]	1.0	1.0	0.0	1.0	1.0	0.0	1.0	1.0	0.0	1.0	1.0	0.0
Walk [s]	0	4	0	0	4	0	0	4	0	0	4	0
Pedestrian Clearance [s]	0	24	0	0	21	0	0	16	0	0	17	0
Delayed Vehicle Green [s]	0.0	0.0	0.0	0.0	0.0	0.0	0.0	0.0	0.0	0.0	0.0	0.0
Rest In Walk		No			No			No			No	
I1, Start-Up Lost Time [s]	2.0	2.0	0.0	2.0	2.0	0.0	2.0	2.0	0.0	2.0	2.0	0.0
I2, Clearance Lost Time [s]	2.0	2.0	0.0	2.0	2.0	0.0	2.0	2.0	0.0	2.0	2.0	0.0
Detector Location [ft]	0.0	0.0	0.0	0.0	0.0	0.0	0.0	0.0	0.0	0.0	0.0	0.0
Detector Length [ft]	20.0	20.0	0.0	20.0	20.0	0.0	20.0	20.0	0.0	20.0	20.0	0.0
I, Upstream Filtering Factor	1.00	1.00	1.00	1.00	1.00	1.00	1.00	1.00	1.00	1.00	1.00	1.00

**Phasing & Timing: Free Running (No Pattern)**

Split [s]	9	14	0	9	14	0	9	14	0	9	14	0
Lead / Lag	Lead	-	-	Lead	-	-	Lead	-	-	Lead	-	-
Minimum Green [s]	5	10	0	5	10	0	5	10	0	5	10	0
Vehicle Extension [s]	2.0	4.0	0.0	2.0	4.0	0.0	2.0	4.0	0.0	2.0	4.0	0.0
Minimum Recall	No	No		No	No		No	Yes		No	Yes	
Maximum Recall	No	No		No	No		No	No		No	No	
Pedestrian Recall	No	No		No	No		No	No		No	No	

**Exclusive Pedestrian Phase**

Pedestrian Signal Group	0
Pedestrian Walk [s]	0
Pedestrian Clearance [s]	0



**Lane Group Calculations**

Lane Group	L	C	L	C	L	C	R	L	C
C, Cycle Length [s]	74	74	74	74	74	74	74	74	74
L, Total Lost Time per Cycle [s]	4.00	4.00	4.00	4.00	4.00	4.00	4.00	4.00	4.00
l1_p, Permitted Start-Up Lost Time [s]	0.00	0.00	0.00	0.00	0.00	0.00	0.00	0.00	0.00
l2, Clearance Lost Time [s]	2.00	2.00	2.00	2.00	2.00	2.00	2.00	2.00	2.00
g_i, Effective Green Time [s]	14	32	2	20	4	22	22	3	20
g / C, Green / Cycle	0.19	0.43	0.03	0.27	0.05	0.29	0.29	0.03	0.27
(v / s)_i Volume / Saturation Flow Rate	0.16	0.04	0.02	0.21	0.04	0.17	0.27	0.02	0.23
s, saturation flow rate [veh/h]	1800	1499	1810	1432	1774	1874	1164	1810	1890
c, Capacity [veh/h]	341	639	59	385	96	546	339	64	515
d1, Uniform Delay [s]	29.14	12.74	35.45	25.21	34.72	22.46	23.14	35.32	25.43
k, delay calibration	0.04	0.15	0.04	0.30	0.04	0.15	0.32	0.04	0.24
l, Upstream Filtering Factor	1.00	1.00	1.00	1.00	1.00	1.00	1.00	1.00	1.00
d2, Incremental Delay [s]	2.36	0.08	2.74	9.38	4.59	1.37	23.09	2.74	7.30
d3, Initial Queue Delay [s]	0.00	0.00	0.00	0.00	0.00	0.00	0.00	0.00	0.00
Rp, platoon ratio	1.00	1.00	1.00	1.00	1.00	1.00	1.00	1.00	1.00
PF, progression factor	1.00	1.00	1.00	1.00	1.00	1.00	1.00	1.00	1.00

**Lane Group Results**

X, volume / capacity	0.85	0.09	0.53	0.78	0.76	0.58	0.92	0.55	0.83
d, Delay for Lane Group [s/veh]	31.50	12.82	38.19	34.59	39.31	23.83	46.23	38.06	32.73
Lane Group LOS	C	B	D	C	D	C	D	D	C
Critical Lane Group	Yes	No	No	Yes	No	No	Yes	Yes	No
50th-Percentile Queue Length [veh/ln]	5.03	0.54	0.58	5.66	1.39	4.65	6.70	0.66	7.71
50th-Percentile Queue Length [ft/ln]	125.66	13.62	14.58	141.62	34.71	116.33	167.40	16.39	192.85
95th-Percentile Queue Length [veh/ln]	8.70	0.98	1.05	9.57	2.50	8.19	10.94	1.18	12.27
95th-Percentile Queue Length [ft/ln]	217.57	24.52	26.24	239.20	62.47	204.77	273.49	29.51	306.72

**Movement, Approach, & Intersection Results**

d_M, Delay for Movement [s/veh]	31.50	12.82	12.82	38.19	34.59	34.59	39.31	23.83	46.23	38.06	32.73	32.73
Movement LOS	C	B	B	D	C	C	D	C	D	D	C	C
d_A, Approach Delay [s/veh]	28.44			34.92			35.42			33.14		
Approach LOS	C			C			D			C		
d_I, Intersection Delay [s/veh]	33.44											
Intersection LOS	C											
Intersection V/C	0.786											

**Emissions**

Vehicle Miles Traveled [mph]	7.93	1.55	1.15	11.23	16.60	71.61	70.70	7.40	90.05
Stops [stops/h]	243.73	26.43	28.28	274.70	67.32	225.64	324.70	31.80	374.06
Fuel consumption [US gal/h]	3.54	0.36	0.44	4.11	1.64	5.72	7.63	0.75	8.61
CO [g/h]	247.31	25.07	31.08	286.98	114.57	400.00	533.35	52.52	601.95
NOx [g/h]	48.12	4.88	6.05	55.84	22.29	77.83	103.77	10.22	117.12
VOC [g/h]	57.32	5.81	7.20	66.51	26.55	92.70	123.61	12.17	139.51

**Other Modes**

g_Walk,mi, Effective Walk Time [s]	8.0	8.0	8.0	8.0
M_corner, Corner Circulation Area [ft <sup>2</sup> /ped]	0.00	0.00	0.00	0.00
M_CW, Crosswalk Circulation Area [ft <sup>2</sup> /ped]	0.00	0.00	0.00	0.00
d_p, Pedestrian Delay [s]	29.55	29.55	29.55	29.55
I_p,int, Pedestrian LOS Score for Intersectio	2.169	2.078	2.534	2.203
Crosswalk LOS	B	B	B	B
s_b, Saturation Flow Rate of the bicycle lane	2000	2000	2000	2000
c_b, Capacity of the bicycle lane [bicycles/h]	808	539	674	674
d_b, Bicycle Delay [s]	13.19	19.81	16.42	16.33
I_b,int, Bicycle LOS Score for Intersection	2.134	2.109	2.713	2.320
Bicycle LOS	B	B	B	B

**Sequence**

Ring 1	1	2	3	4	-	-	-	-	-	-	-	-	-	-	-
Ring 2	5	6	7	8	-	-	-	-	-	-	-	-	-	-	-
Ring 3	-	-	-	-	-	-	-	-	-	-	-	-	-	-	-
Ring 4	-	-	-	-	-	-	-	-	-	-	-	-	-	-	-



**Intersection Level Of Service Report**

**Intersection 15: Central Parkway & Panorama Drive/Pino Grande Road**

Control Type:	All-way stop	Delay (sec / veh):	11.0
Analysis Method:	HCM 7th Edition	Level Of Service:	B
Analysis Period:	15 minutes	Volume to Capacity (v/c):	0.359

**Intersection Setup**

Name	Pino Grande Road			Panorama Drive			Central Parkway			Central Parkway		
Approach	Northbound			Southbound			Eastbound			Westbound		
Lane Configuration	+			+			+			+		
Turning Movement	Left	Thru	Right	Left	Thru	Right	Left	Thru	Right	Left	Thru	Right
Lane Width [ft]	12.00	12.00	12.00	12.00	12.00	12.00	12.00	12.00	12.00	12.00	12.00	12.00
No. of Lanes in Entry Pocket	0	0	0	0	0	1	1	0	0	1	0	0
Entry Pocket Length [ft]	100.00	100.00	100.00	100.00	100.00	100.00	275.00	100.00	100.00	100.00	100.00	100.00
No. of Lanes in Exit Pocket	0	0	0	0	0	0	0	0	0	0	0	0
Exit Pocket Length [ft]	0.00	0.00	0.00	0.00	0.00	0.00	0.00	0.00	0.00	0.00	0.00	0.00
Speed [mph]	30.00			30.00			30.00			30.00		
Grade [%]	0.00			0.00			0.00			0.00		
Crosswalk	Yes			Yes			Yes			Yes		

**Volumes**

Name	Pino Grande Road			Panorama Drive			Central Parkway			Central Parkway		
Base Volume Input [veh/h]	37	2	1	1	4	127	97	84	6	0	91	2
Base Volume Adjustment Factor	1.0000	1.0000	1.0000	1.0000	1.0000	1.0000	1.0000	1.0000	1.0000	1.0000	1.0000	1.0000
Heavy Vehicles Percentage [%]	0.00	0.00	0.00	0.00	0.00	0.00	2.10	1.20	0.00	0.00	0.00	0.00
Growth Factor	1.0000	1.0000	1.0000	1.0000	1.0000	1.0000	1.0000	1.0000	1.0000	1.0000	1.0000	1.0000
In-Process Volume [veh/h]	0	0	0	0	0	0	0	0	0	0	0	0
Site-Generated Trips [veh/h]	0	0	0	0	0	0	0	0	0	0	0	0
Diverted Trips [veh/h]	0	0	0	0	0	0	0	0	0	0	0	0
Pass-by Trips [veh/h]	0	0	0	0	0	0	0	0	0	0	0	0
Existing Site Adjustment Volume [veh/h]	0	0	0	0	0	0	0	0	0	0	0	0
Other Volume [veh/h]	0	0	0	0	0	0	0	0	0	0	0	0
Total Hourly Volume [veh/h]	37	2	1	1	4	127	97	84	6	0	91	2
Peak Hour Factor	0.5300	0.5300	0.5300	0.5300	0.5300	0.5300	0.5300	0.5300	0.5300	0.5300	0.5300	0.5300
Other Adjustment Factor	1.0000	1.0000	1.0000	1.0000	1.0000	1.0000	1.0000	1.0000	1.0000	1.0000	1.0000	1.0000
Total 15-Minute Volume [veh/h]	17	1	0	0	2	60	46	40	3	0	43	1
Total Analysis Volume [veh/h]	70	4	2	2	8	240	183	158	11	0	172	4
Pedestrian Volume [ped/h]	117			1			103			89		



**Intersection Settings****Lanes**

Capacity per Entry Lane [veh/h]	550	581	668	578	636	607	609
Degree of Utilization, x	0.14	0.02	0.36	0.32	0.27	0.00	0.29





**Movement, Approach, & Intersection Results**

95th-Percentile Queue Length [veh]	0.48	0.05	1.63	1.35	1.07	0.00	1.19
95th-Percentile Queue Length [ft]	11.93	1.31	40.84	33.84	26.68	0.00	29.85
Approach Delay [s/veh]	10.59	11.00		11.13		11.00	
Approach LOS	B	B		B		B	
Intersection Delay [s/veh]	11.02						
Intersection LOS	B						

**Intersection Level Of Service Report**  
**Intersection 16: Airway Boulevard & N. Canyons Parkway**

Control Type:	Signalized	Delay (sec / veh):	23.8
Analysis Method:	HCM 7th Edition	Level Of Service:	C
Analysis Period:	15 minutes	Volume to Capacity (v/c):	0.688

**Intersection Setup**

Name	Airway Boulevard			Driveway			N. Canyons Parkway			N Canyons Parkway		
Approach	Northbound			Southbound			Eastbound			Westbound		
Lane Configuration												
Turning Movement	Left	Thru	Right	Left	Thru	Right	Left	Thru	Right	Left	Thru	Right
Lane Width [ft]	12.00	12.00	12.00	12.00	12.00	12.00	12.00	12.00	12.00	12.00	12.00	12.00
No. of Lanes in Entry Pocket	1	0	0	0	0	0	0	0	0	1	0	1
Entry Pocket Length [ft]	100.00	100.00	100.00	100.00	100.00	100.00	100.00	100.00	100.00	110.00	100.00	195.00
No. of Lanes in Exit Pocket	0	0	0	0	0	0	0	0	0	0	0	0
Exit Pocket Length [ft]	0.00	0.00	0.00	0.00	0.00	0.00	0.00	0.00	0.00	0.00	0.00	0.00
Speed [mph]	40.00			30.00			40.00			40.00		
Grade [%]	0.00			0.00			0.00			0.00		
Curb Present	Yes			Yes			Yes			Yes		
Crosswalk	Yes			Yes			Yes			No		





**Volumes**

Name	Airway Boulevard			Driveway			N. Canyons Parkway			N Canyons Parkway		
Base Volume Input [veh/h]	820	14	558	1	4	0	0	143	149	630	1163	1
Base Volume Adjustment Factor	1.0000	1.0000	1.0000	1.0000	1.0000	1.0000	1.0000	1.0000	1.0000	1.0000	1.0000	1.0000
Heavy Vehicles Percentage [%]	3.60	0.00	2.10	0.00	0.00	0.00	2.00	0.00	22.60	4.40	0.00	0.00
Proportion of CAVs [%]	0.00											
Growth Factor	1.0000	1.0000	1.0000	1.0000	1.0000	1.0000	1.0000	1.0000	1.0000	1.0000	1.0000	1.0000
In-Process Volume [veh/h]	0	0	0	0	0	0	0	0	0	0	0	0
Site-Generated Trips [veh/h]	0	0	0	0	0	0	0	0	0	0	0	0
Diverted Trips [veh/h]	0	0	0	0	0	0	0	0	0	0	0	0
Pass-by Trips [veh/h]	0	0	0	0	0	0	0	0	0	0	0	0
Existing Site Adjustment Volume [veh/h]	0	0	0	0	0	0	0	0	0	0	0	0
Other Volume [veh/h]	0	0	0	0	0	0	0	0	0	0	0	0
Right Turn on Red Volume [veh/h]	0	0	0	0	0	0	0	0	0	0	0	0
Total Hourly Volume [veh/h]	820	14	558	1	4	0	0	143	149	630	1163	1
Peak Hour Factor	0.8900	0.8900	0.8900	0.8900	0.8900	0.8900	1.0000	0.8900	0.8900	0.8900	0.8900	0.8900
Other Adjustment Factor	1.0000	1.0000	1.0000	1.0000	1.0000	1.0000	1.0000	1.0000	1.0000	1.0000	1.0000	1.0000
Total 15-Minute Volume [veh/h]	230	4	157	0	1	0	0	40	42	177	327	0
Total Analysis Volume [veh/h]	921	16	627	1	4	0	0	161	167	708	1307	1
Presence of On-Street Parking	No		No	No		No	No		No	No		No
On-Street Parking Maneuver Rate [/h]	0	0	0	0	0	0	0	0	0	0	0	0
Local Bus Stopping Rate [/h]	0	0	0	0	0	0	0	0	0	0	0	0
v_do, Outbound Pedestrian Volume crossing	0			0			0			0		
v_di, Inbound Pedestrian Volume crossing m	0			0			0			0		
v_co, Outbound Pedestrian Volume crossing	0			1			0			0		
v_ci, Inbound Pedestrian Volume crossing mi	0			0			0			1		
v_ab, Corner Pedestrian Volume [ped/h]	0			0			0			0		
Bicycle Volume [bicycles/h]	0			0			0			0		



**Intersection Settings**

Located in CBD	No
Signal Coordination Group	-
Cycle Length [s]	105
Active Pattern	Pattern 1
Coordination Type	Time of Day Pattern Coordinated
Actuation Type	Fully actuated
Offset [s]	0.0
Offset Reference	Lead Green - Beginning of First Green
Permissive Mode	SingleBand
Lost time [s]	12.00

**Phasing & Timing (Basic)**

Control Type	Split	Split	Overlap	Split	Split	Split	Permiss	Permiss	Permiss	Protecte	Permiss	Permiss
Signal Group	0	8	8	0	4	0	0	2	0	1	6	0
Auxiliary Signal Groups			1,8									
Maximum Green [s]	0	20	20	0	12	0	0	15	0	50	50	0
Amber [s]	0.0	3.2	3.2	0.0	3.0	0.0	0.0	5.0	0.0	5.0	5.0	0.0
All red [s]	0.0	1.0	1.0	0.0	1.0	0.0	0.0	1.0	0.0	1.0	1.0	0.0
Walk [s]	0	0	0	0	5	0	0	5	0	0	5	0
Pedestrian Clearance [s]	0	0	0	0	28	0	0	29	0	0	12	0
Delayed Vehicle Green [s]	0.0	0.0	0.0	0.0	0.0	0.0	0.0	0.0	0.0	0.0	0.0	0.0
Rest In Walk		No			No			No			No	
I1, Start-Up Lost Time [s]	0.0	2.0	2.0	0.0	2.0	0.0	0.0	2.0	0.0	2.0	2.0	0.0
I2, Clearance Lost Time [s]	0.0	2.0	2.0	0.0	2.0	0.0	0.0	2.0	0.0	2.0	2.0	0.0
Detector Location [ft]	0.0	0.0	0.0	0.0	0.0	0.0	0.0	0.0	0.0	0.0	0.0	0.0
Detector Length [ft]	0.0	0.0	0.0	0.0	20.0	0.0	0.0	20.0	0.0	0.0	0.0	0.0
I, Upstream Filtering Factor	1.00	1.00	1.00	1.00	1.00	1.00	1.00	1.00	1.00	1.00	1.00	1.00

**Phasing & Timing: Pattern 1**

Split [s]	0	15	15	0	41	0	0	40	0	9	49	0
Lead / Lag	-	-	-	-	-	-	-	-	-	Lead	-	-
Minimum Green [s]	0	4	4	0	3	0	0	10	0	3	7	0
Vehicle Extension [s]	0.0	2.0	2.0	0.0	2.0	0.0	0.0	2.0	0.0	2.0	2.0	0.0
Minimum Recall		No	No		No			No		No	Yes	
Maximum Recall		No	No		No			No		Yes	Yes	
Pedestrian Recall		No	No		No			No		No	No	

**Exclusive Pedestrian Phase**

Pedestrian Signal Group	0
Pedestrian Walk [s]	0
Pedestrian Clearance [s]	0



**Lane Group Calculations**

Lane Group	L	C	R	C	C	R	L	C	C
C, Cycle Length [s]	105	105	105	105	105	105	105	105	105
L, Total Lost Time per Cycle [s]	4.00	4.00	4.00	4.00	4.00	4.00	4.00	4.00	4.00
l1_p, Permitted Start-Up Lost Time [s]	0.00	0.00	0.00	0.00	0.00	0.00	0.00	0.00	0.00
l2, Clearance Lost Time [s]	2.00	2.00	0.00	2.00	2.00	2.00	2.00	2.00	2.00
g_i, Effective Green Time [s]	31	31	75	0	17	17	41	62	62
g / C, Green / Cycle	0.29	0.29	0.72	0.00	0.16	0.16	0.39	0.59	0.59
(v / s)_i Volume / Saturation Flow Rate	0.26	0.26	0.22	0.00	0.04	0.13	0.21	0.34	0.34
s, saturation flow rate [veh/h]	1758	1812	2811	1881	3618	1327	3392	1900	1899
c, Capacity [veh/h]	510	526	1967	8	589	216	1325	1124	1124
d1, Uniform Delay [s]	35.88	35.86	6.09	52.22	38.52	42.10	24.65	13.36	13.36
k, delay calibration	0.04	0.04	0.50	0.04	0.04	0.04	0.50	0.50	0.50
l, Upstream Filtering Factor	1.00	1.00	1.00	1.00	1.00	1.00	1.00	1.00	1.00
d2, Incremental Delay [s]	2.55	2.44	0.43	29.18	0.09	2.23	1.55	2.20	2.21
d3, Initial Queue Delay [s]	0.00	0.00	0.00	0.00	0.00	0.00	0.00	0.00	0.00
Rp, platoon ratio	1.00	1.00	1.00	1.00	1.00	1.00	1.00	1.00	1.00
PF, progression factor	1.00	1.00	1.00	1.00	1.00	1.00	1.00	1.00	1.00

**Lane Group Results**

X, volume / capacity	0.91	0.90	0.32	0.65	0.27	0.77	0.53	0.58	0.58
d, Delay for Lane Group [s/veh]	38.44	38.31	6.52	81.40	38.61	44.33	26.20	15.57	15.57
Lane Group LOS	D	D	A	F	D	D	C	B	B
Critical Lane Group	Yes	No	No	Yes	No	No	No	No	Yes
50th-Percentile Queue Length [veh/ln]	11.23	11.54	2.30	0.19	1.78	4.16	6.75	9.25	9.25
50th-Percentile Queue Length [ft/ln]	280.77	288.44	57.55	4.84	44.60	104.05	168.69	231.28	231.32
95th-Percentile Queue Length [veh/ln]	16.73	17.11	4.14	0.35	3.21	7.49	11.01	14.24	14.24
95th-Percentile Queue Length [ft/ln]	418.17	427.71	103.59	8.72	80.27	187.29	275.20	355.99	356.04

**Movement, Approach, & Intersection Results**

d_M, Delay for Movement [s/veh]	38.37	38.31	6.52	81.40	81.40	81.40	0.00	38.61	44.33	26.20	15.57	15.57
Movement LOS	D	D	A	F	F	F		D	D	C	B	B
d_A, Approach Delay [s/veh]	25.60			81.40				41.52		19.30		
Approach LOS	C			F				D		B		
d_I, Intersection Delay [s/veh]	23.76											
Intersection LOS	C											
Intersection V/C	0.688											

**Emissions**

Vehicle Miles Traveled [mph]	54.83	56.43	74.45	0.17	10.49	10.89	57.90	53.49	53.49
Stops [stops/h]	385.01	395.54	157.83	6.64	122.31	142.68	462.65	317.15	317.21
Fuel consumption [US gal/h]	9.36	9.61	5.05	0.13	2.84	3.30	10.39	7.10	7.10
CO [g/h]	654.09	671.84	352.95	8.85	198.68	230.53	726.48	496.52	496.60
NOx [g/h]	127.26	130.72	68.67	1.72	38.66	44.85	141.35	96.61	96.62
VOC [g/h]	151.59	155.71	81.80	2.05	46.05	53.43	168.37	115.07	115.09

**Other Modes**

g_Walk,mi, Effective Walk Time [s]	9.0	9.0	9.0	0.0
M_corner, Corner Circulation Area [ft <sup>2</sup> /ped]	0.00	0.00	0.00	0.00
M_CW, Crosswalk Circulation Area [ft <sup>2</sup> /ped]	0.00	5854.23	0.00	0.00
d_p, Pedestrian Delay [s]	43.89	43.89	43.89	0.00
I_p,int, Pedestrian LOS Score for Intersectio	3.057	1.735	2.973	0.000
Crosswalk LOS	C	A	C	F
s_b, Saturation Flow Rate of the bicycle lane	2000	2000	2000	2000
c_b, Capacity of the bicycle lane [bicycles/h]	206	705	648	819
d_b, Bicycle Delay [s]	42.26	22.02	24.01	18.31
I_b,int, Bicycle LOS Score for Intersection	4.140	1.568	1.830	3.223
Bicycle LOS	D	A	A	C

**Sequence**

Ring 1	1	2	4	8	-	-	-	-	-	-	-	-	-	-	-
Ring 2	-	6	-	-	-	-	-	-	-	-	-	-	-	-	-
Ring 3	-	-	-	-	-	-	-	-	-	-	-	-	-	-	-
Ring 4	-	-	-	-	-	-	-	-	-	-	-	-	-	-	-

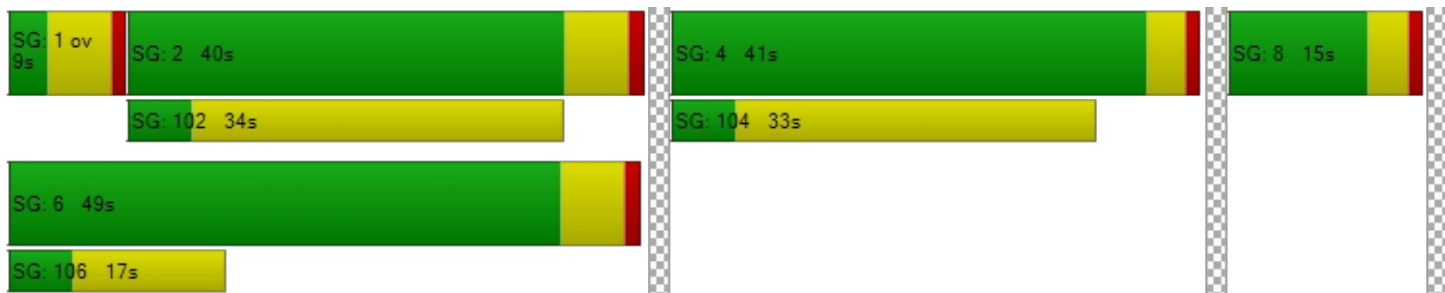

**Intersection Level Of Service Report**  
**Intersection 17: Airway Boulevard & I-580 WB Ramps**

Control Type:	Signalized	Delay (sec / veh):	64.2
Analysis Method:	HCM 7th Edition	Level Of Service:	E
Analysis Period:	15 minutes	Volume to Capacity (v/c):	0.472

**Intersection Setup**

Name	Airway Boulevard			Airway Boulevard			I-580 WB On-Ramp			I-580 WB Off-Ramp		
Approach	Northbound			Southbound			Eastbound			Westbound		
Lane Configuration	r			r						r rr		
Turning Movement	Left	Thru	Right	Left	Thru	Right	Left	Thru	Right	Left	Thru	Right
Lane Width [ft]	12.00	12.00	12.00	12.00	12.00	12.00	12.00	12.00	12.00	12.00	12.00	12.00
No. of Lanes in Entry Pocket	0	0	0	0	0	1	0	0	0	1	0	1
Entry Pocket Length [ft]	100.00	100.00	100.00	100.00	100.00	250.00	100.00	100.00	100.00	150.00	100.00	490.00
No. of Lanes in Exit Pocket	0	0	0	0	0	0	0	0	0	0	0	0
Exit Pocket Length [ft]	0.00	0.00	0.00	0.00	0.00	0.00	0.00	0.00	0.00	0.00	0.00	0.00
Speed [mph]	40.00			40.00			30.00			45.00		
Grade [%]	0.00			0.00			0.00			0.00		
Curb Present	Yes			Yes						Yes		
Crosswalk	No			No			No			Yes		



**Volumes**

Name	Airway Boulevard			Airway Boulevard			I-580 WB On-Ramp			I-580 WB Off-Ramp		
	Base Volume Input [veh/h]	0	819	131	0	204	616	0	0	0	48	0
Base Volume Adjustment Factor	1.0000	1.0000	1.0000	1.0000	1.0000	1.0000	1.0000	1.0000	1.0000	1.0000	1.0000	1.0000
Heavy Vehicles Percentage [%]	2.00	2.90	9.20	2.00	5.70	6.80	2.00	2.00	2.00	4.20	0.00	8.50
Proportion of CAVs [%]	0.00											
Growth Factor	1.0000	1.0000	1.0000	1.0000	1.0000	1.0000	1.0000	1.0000	1.0000	1.0000	1.0000	1.0000
In-Process Volume [veh/h]	0	0	0	0	0	0	0	0	0	0	0	0
Site-Generated Trips [veh/h]	0	0	0	0	0	0	0	0	0	0	0	0
Diverted Trips [veh/h]	0	0	0	0	0	0	0	0	0	0	0	0
Pass-by Trips [veh/h]	0	0	0	0	0	0	0	0	0	0	0	0
Existing Site Adjustment Volume [veh/h]	0	0	0	0	0	0	0	0	0	0	0	0
Other Volume [veh/h]	0	0	0	0	0	0	0	0	0	0	0	0
Right Turn on Red Volume [veh/h]	0	0	0	0	0	0	0	0	0	0	0	0
Total Hourly Volume [veh/h]	0	819	131	0	204	616	0	0	0	48	0	745
Peak Hour Factor	1.0000	0.8700	0.8700	1.0000	0.8700	0.8700	1.0000	1.0000	1.0000	0.8700	0.8700	0.8700
Other Adjustment Factor	1.0000	1.0000	1.0000	1.0000	1.0000	1.0000	1.0000	1.0000	1.0000	1.0000	1.0000	1.0000
Total 15-Minute Volume [veh/h]	0	235	38	0	59	177	0	0	0	14	0	214
Total Analysis Volume [veh/h]	0	941	151	0	234	708	0	0	0	55	0	856
Presence of On-Street Parking	No		No	No		No				No		No
On-Street Parking Maneuver Rate [/h]	0	0	0	0	0	0	0	0	0	0	0	0
Local Bus Stopping Rate [/h]	0	0	0	0	0	0	0	0	0	0	0	0
v_do, Outbound Pedestrian Volume crossing	0			0			0			0		
v_di, Inbound Pedestrian Volume crossing m	0			0			0			0		
v_co, Outbound Pedestrian Volume crossing	1			0			0			1		
v_ci, Inbound Pedestrian Volume crossing mi	1			0			0			1		
v_ab, Corner Pedestrian Volume [ped/h]	0			0			0			0		
Bicycle Volume [bicycles/h]	0			0			0			0		



**Intersection Settings**

Located in CBD	No
Signal Coordination Group	-
Cycle Length [s]	105
Active Pattern	Pattern 1
Coordination Type	Time of Day Pattern Coordinated
Actuation Type	Fully actuated
Offset [s]	91.0
Offset Reference	Lead Green - Beginning of First Green
Permissive Mode	SingleBand
Lost time [s]	9.00

**Phasing & Timing (Basic)**

Control Type	Permiss	Permiss	Unsigna	Permiss	Permiss	Unsigna	Permiss	Permiss	Permiss	Permiss	Permiss	Overlap
Signal Group	0	2	0	0	6	0	0	0	0	0	8	1
Auxiliary Signal Groups												1,8
Maximum Green [s]	0	30	0	0	25	0	0	0	0	0	20	12
Amber [s]	0.0	4.3	0.0	0.0	4.3	0.0	0.0	0.0	0.0	0.0	3.0	3.0
All red [s]	0.0	1.0	0.0	0.0	1.0	0.0	0.0	0.0	0.0	0.0	1.0	0.0
Walk [s]	0	7	0	0	0	0	0	0	0	0	0	0
Pedestrian Clearance [s]	0	15	0	0	0	0	0	0	0	0	0	0
Delayed Vehicle Green [s]	0.0	0.0	0.0	0.0	0.0	0.0	0.0	0.0	0.0	0.0	0.0	0.0
Rest In Walk		No			No						No	
I1, Start-Up Lost Time [s]	0.0	2.0	0.0	0.0	2.0	0.0	0.0	0.0	0.0	0.0	2.0	2.0
I2, Clearance Lost Time [s]	0.0	2.0	0.0	0.0	2.0	0.0	0.0	0.0	0.0	0.0	2.0	2.0
Detector Location [ft]	0.0	0.0	0.0	0.0	0.0	0.0	0.0	0.0	0.0	0.0	0.0	0.0
Detector Length [ft]	0.0	20.0	0.0	0.0	20.0	0.0	0.0	0.0	0.0	0.0	20.0	20.0
I, Upstream Filtering Factor	1.00	1.00	1.00	1.00	1.00	1.00	1.00	1.00	1.00	1.00	1.00	1.00

**Phasing & Timing: Pattern 1**

Split [s]	0	74	0	0	89	0	0	0	0	0	16	15
Lead / Lag	-	-	-	-	-	-	-	-	-	-	-	-
Minimum Green [s]	0	11	0	0	8	0	0	0	0	0	4	4
Vehicle Extension [s]	0.0	0.0	0.0	0.0	0.0	0.0	0.0	0.0	0.0	0.0	0.0	0.0
Minimum Recall		Yes			Yes						No	No
Maximum Recall		No			No						No	No
Pedestrian Recall		No			No						No	No

**Exclusive Pedestrian Phase**

Pedestrian Signal Group	0
Pedestrian Walk [s]	0
Pedestrian Clearance [s]	0



**Lane Group Calculations**

Lane Group	C	C		L	C	R
C, Cycle Length [s]	105	105		105	105	105
L, Total Lost Time per Cycle [s]	4.00	4.00		4.00	4.00	4.00
l1_p, Permitted Start-Up Lost Time [s]	0.00	0.00		0.00	0.00	0.00
l2, Clearance Lost Time [s]	2.00	2.00		2.00	2.00	0.00
g_i, Effective Green Time [s]	70	85		12	12	27
g / C, Green / Cycle	0.67	0.81		0.11	0.11	0.26
(v / s)_i Volume / Saturation Flow Rate	0.27	0.05		0.02	0.02	0.32
s, saturation flow rate [veh/h]	3535	4943		1749	1810	2667
c, Capacity [veh/h]	2355	4000		200	207	712
d1, Uniform Delay [s]	7.96	2.00		41.80	41.78	41.17
k, delay calibration	0.50	0.50		0.04	0.04	0.50
l, Upstream Filtering Factor	1.00	1.00		1.00	1.00	1.00
d2, Incremental Delay [s]	0.51	0.03		0.11	0.11	104.22
d3, Initial Queue Delay [s]	0.00	0.00		0.00	0.00	0.00
Rp, platoon ratio	1.00	1.00		1.00	1.00	1.00
PF, progression factor	1.00	1.00		1.00	1.00	1.00

**Lane Group Results**

X, volume / capacity	0.40	0.06		0.14	0.13	1.20
d, Delay for Lane Group [s/veh]	8.47	2.03		41.91	41.88	145.39
Lane Group LOS	A	A		D	D	F
Critical Lane Group	Yes	No		No	No	Yes
50th-Percentile Queue Length [veh/ln]	4.26	0.19		0.63	0.63	18.95
50th-Percentile Queue Length [ft/ln]	106.53	4.80		15.71	15.69	473.86
95th-Percentile Queue Length [veh/ln]	7.65	0.35		1.13	1.13	28.82
95th-Percentile Queue Length [ft/ln]	191.16	8.65		28.27	28.24	720.46



**Movement, Approach, & Intersection Results**

d_M, Delay for Movement [s/veh]	0.00	8.47	0.00	0.00	2.03	0.00	0.00	0.00	0.00	0.00	41.91	41.88	145.39
Movement LOS		A			A						D	D	F
d_A, Approach Delay [s/veh]	7.43		0.56			0.00			139.14				
Approach LOS	A		A			A			F				
d_I, Intersection Delay [s/veh]	64.18												
Intersection LOS	E												
Intersection V/C	0.472												

**Emissions**

Vehicle Miles Traveled [mph]	78.50	27.79	2.70	2.70	84.19
Stops [stops/h]	292.28	19.77	21.55	21.53	1300.10
Fuel consumption [US gal/h]	7.30	1.29	0.60	0.59	44.37
CO [g/h]	510.61	89.91	41.60	41.57	3101.60
NOx [g/h]	99.35	17.49	8.09	8.09	603.46
VOC [g/h]	118.34	20.84	9.64	9.63	718.83

**Other Modes**

g_Walk,mi, Effective Walk Time [s]	0.0	0.0	0.0	11.0
M_corner, Corner Circulation Area [ft <sup>2</sup> /ped]	0.00	0.00	0.00	0.00
M_CW, Crosswalk Circulation Area [ft <sup>2</sup> /ped]	0.00	0.00	0.00	0.00
d_p, Pedestrian Delay [s]	0.00	0.00	0.00	42.06
I_p,int, Pedestrian LOS Score for Intersectio	0.000	0.000	0.000	2.574
Crosswalk LOS	F	F	F	B
s_b, Saturation Flow Rate of the bicycle lane	2000	2000	2000	2000
c_b, Capacity of the bicycle lane [bicycles/h]	1309	1595	0	229
d_b, Bicycle Delay [s]	6.27	2.15	52.49	41.17
I_b,int, Bicycle LOS Score for Intersection	2.336	1.688	4.132	3.063
Bicycle LOS	B	A	D	C

**Sequence**

Ring 1	1	2	-	-	-	-	-	-	-	-	-	-	-	-	-	-
Ring 2	-	6	-	8	-	-	-	-	-	-	-	-	-	-	-	-
Ring 3	-	-	-	-	-	-	-	-	-	-	-	-	-	-	-	-
Ring 4	-	-	-	-	-	-	-	-	-	-	-	-	-	-	-	-



**Intersection Level Of Service Report**  
**Intersection 20: Croak Road & Central Parkway**

Control Type:	All-way stop	Delay (sec / veh):	11.6
Analysis Method:	HCM 7th Edition	Level Of Service:	B
Analysis Period:	15 minutes	Volume to Capacity (v/c):	0.495

**Intersection Setup**

Name	Croak Road			Croak Road			Central Parkway					
Approach	Northbound			Southbound			Eastbound			Westbound		
Lane Configuration	+			+			+			+		
Turning Movement	Left	Thru	Right	Left	Thru	Right	Left	Thru	Right	Left	Thru	Right
Lane Width [ft]	12.00	12.00	12.00	12.00	12.00	12.00	12.00	12.00	12.00	12.00	12.00	12.00
No. of Lanes in Entry Pocket	0	0	0	0	0	0	0	0	0	0	0	0
Entry Pocket Length [ft]	100.00	100.00	100.00	100.00	100.00	100.00	100.00	100.00	100.00	100.00	100.00	100.00
No. of Lanes in Exit Pocket	0	0	0	0	0	0	0	0	0	0	0	0
Exit Pocket Length [ft]	0.00	0.00	0.00	0.00	0.00	0.00	0.00	0.00	0.00	0.00	0.00	0.00
Speed [mph]	30.00			30.00			25.00			30.00		
Grade [%]	0.00			0.00			0.00			0.00		
Crosswalk	Yes			Yes			Yes			Yes		

**Volumes**

Name	Croak Road			Croak Road			Central Parkway					
Base Volume Input [veh/h]	22	36	9	0	117	143	51	246	56	27	152	0
Base Volume Adjustment Factor	1.0000	1.0000	1.0000	1.0000	1.0000	1.0000	1.0000	1.0000	1.0000	1.0000	1.0000	1.0000
Heavy Vehicles Percentage [%]	2.00	2.00	2.00	2.00	2.00	2.00	2.00	2.00	2.00	2.00	2.00	2.00
Growth Factor	1.0000	1.0000	1.0000	1.0000	1.0000	1.0000	1.0000	1.0000	1.0000	1.0000	1.0000	1.0000
In-Process Volume [veh/h]	0	0	0	0	0	0	0	0	0	0	0	0
Site-Generated Trips [veh/h]	0	0	0	0	0	0	0	0	0	0	0	0
Diverted Trips [veh/h]	0	0	0	0	0	0	0	0	0	0	0	0
Pass-by Trips [veh/h]	0	0	0	0	0	0	0	0	0	0	0	0
Existing Site Adjustment Volume [veh/h]	0	0	0	0	0	0	0	0	0	0	0	0
Other Volume [veh/h]	0	0	0	0	0	0	0	0	0	0	0	0
Total Hourly Volume [veh/h]	22	36	9	0	117	143	51	246	56	27	152	0
Peak Hour Factor	1.0000	1.0000	1.0000	1.0000	1.0000	1.0000	1.0000	1.0000	1.0000	1.0000	1.0000	1.0000
Other Adjustment Factor	1.0000	1.0000	1.0000	1.0000	1.0000	1.0000	1.0000	1.0000	1.0000	1.0000	1.0000	1.0000
Total 15-Minute Volume [veh/h]	6	9	2	0	29	36	13	62	14	7	38	0
Total Analysis Volume [veh/h]	22	36	9	0	117	143	51	246	56	27	152	0
Pedestrian Volume [ped/h]	0			0			0			0		



**Intersection Settings**

**Lanes**

Capacity per Entry Lane [veh/h]	623	703	713	668
Degree of Utilization, x	0.11	0.37	0.49	0.27

**Movement, Approach, & Intersection Results**

95th-Percentile Queue Length [veh]	0.36	1.71	2.77	1.08
95th-Percentile Queue Length [ft]	8.99	42.71	69.24	26.98
Approach Delay [s/veh]	9.47	11.10	12.89	10.35
Approach LOS	A	B	B	B
Intersection Delay [s/veh]	11.55			
Intersection LOS	B			



**Intersection Level Of Service Report**  
**Intersection 22: Croak Road & Dublin Boulevard**

Control Type:	Signalized	Delay (sec / veh):	21.1
Analysis Method:	HCM 7th Edition	Level Of Service:	C
Analysis Period:	15 minutes	Volume to Capacity (v/c):	0.622

**Intersection Setup**

Name	Croak Road			Croak Road			Dublin Boulevard			Dublin Boulevard		
Approach	Northbound			Southbound			Eastbound			Westbound		
Lane Configuration												
Turning Movement	Left	Thru	Right	Left	Thru	Right	Left	Thru	Right	Left	Thru	Right
Lane Width [ft]	12.00	12.00	12.00	12.00	12.00	12.00	12.00	12.00	12.00	12.00	12.00	12.00
No. of Lanes in Entry Pocket	1	0	0	1	0	1	1	0	1	1	0	1
Entry Pocket Length [ft]	100.00	100.00	100.00	100.00	100.00	100.00	210.00	100.00	250.00	150.00	100.00	250.00
No. of Lanes in Exit Pocket	0	0	0	0	0	0	0	0	1	0	0	0
Exit Pocket Length [ft]	0.00	0.00	0.00	0.00	0.00	0.00	0.00	0.00	49.21	0.00	0.00	0.00
Speed [mph]	30.00			30.00			30.00			30.00		
Grade [%]	0.00			0.00			0.00			0.00		
Curb Present	No			No			No			No		
Crosswalk	Yes			Yes			Yes			Yes		



**Volumes**

Name	Croak Road			Croak Road			Dublin Boulevard			Dublin Boulevard		
Base Volume Input [veh/h]	0	0	8	47	0	1	0	313	0	0	1937	12
Base Volume Adjustment Factor	1.0000	1.0000	1.0000	1.0000	1.0000	1.0000	1.0000	1.0000	1.0000	1.0000	1.0000	1.0000
Heavy Vehicles Percentage [%]	2.00	2.00	2.00	2.00	2.00	2.00	2.00	2.00	2.00	2.00	2.00	2.00
Proportion of CAVs [%]	0.00											
Growth Factor	1.0000	1.0000	1.0000	1.0000	1.0000	1.0000	1.0000	1.0000	1.0000	1.0000	1.0000	1.0000
In-Process Volume [veh/h]	0	0	0	0	0	0	0	0	0	0	0	0
Site-Generated Trips [veh/h]	0	0	0	0	0	0	0	0	0	0	0	0
Diverted Trips [veh/h]	0	0	0	0	0	0	0	0	0	0	0	0
Pass-by Trips [veh/h]	0	0	0	0	0	0	0	0	0	0	0	0
Existing Site Adjustment Volume [veh/h]	0	0	0	0	0	0	0	0	0	0	0	0
Other Volume [veh/h]	0	0	0	0	0	0	0	0	0	0	0	0
Right Turn on Red Volume [veh/h]	0	0	0	0	0	0	0	0	0	0	0	0
Total Hourly Volume [veh/h]	0	0	8	47	0	1	0	313	0	0	1937	12
Peak Hour Factor	1.0000	1.0000	1.0000	1.0000	1.0000	1.0000	1.0000	1.0000	1.0000	1.0000	1.0000	1.0000
Other Adjustment Factor	1.0000	1.0000	1.0000	1.0000	1.0000	1.0000	1.0000	1.0000	1.0000	1.0000	1.0000	1.0000
Total 15-Minute Volume [veh/h]	0	0	2	12	0	0	0	78	0	0	484	3
Total Analysis Volume [veh/h]	0	0	8	47	0	1	0	313	0	0	1937	12
Presence of On-Street Parking	No		No	No		No	No		No	No		No
On-Street Parking Maneuver Rate [/h]	0	0	0	0	0	0	0	0	0	0	0	0
Local Bus Stopping Rate [/h]	0	0	0	0	0	0	0	0	0	0	0	0
v_do, Outbound Pedestrian Volume crossing	0			0			0			0		
v_di, Inbound Pedestrian Volume crossing m	0			0			0			0		
v_co, Outbound Pedestrian Volume crossing	0			0			0			0		
v_ci, Inbound Pedestrian Volume crossing mi	0			0			0			0		
v_ab, Corner Pedestrian Volume [ped/h]	0			0			0			0		
Bicycle Volume [bicycles/h]	0			0			0			0		



**Intersection Settings**

Located in CBD	No
Signal Coordination Group	-
Cycle Length [s]	160
Active Pattern	Pattern 1
Coordination Type	Time of Day Pattern Isolated
Actuation Type	Fully actuated
Offset [s]	0.0
Offset Reference	Lead Green - Beginning of First Green
Permissive Mode	SingleBand
Lost time [s]	12.00

**Phasing & Timing (Basic)**

Control Type	Protecte	Permiss	Permiss	Protecte	Permiss	Permiss	Protecte	Permiss	Permiss	Protecte	Permiss	Permiss
Signal Group	1	6	0	5	2	0	3	8	0	7	4	0
Auxiliary Signal Groups												
Maximum Green [s]	5	26	0	5	26	0	5	126	0	5	126	0
Amber [s]	3.0	3.0	0.0	3.0	3.0	0.0	3.0	3.0	0.0	3.0	3.0	0.0
All red [s]	1.0	1.0	0.0	1.0	1.0	0.0	1.0	1.0	0.0	1.0	1.0	0.0
Walk [s]	0	5	0	0	5	0	0	5	0	0	5	0
Pedestrian Clearance [s]	0	21	0	0	21	0	0	10	0	0	10	0
Delayed Vehicle Green [s]	0.0	0.0	0.0	0.0	0.0	0.0	0.0	0.0	0.0	0.0	0.0	0.0
Rest In Walk		No			No			No			No	
I1, Start-Up Lost Time [s]	2.0	2.0	0.0	2.0	2.0	0.0	2.0	2.0	0.0	2.0	2.0	0.0
I2, Clearance Lost Time [s]	2.0	2.0	0.0	2.0	2.0	0.0	2.0	2.0	0.0	2.0	2.0	0.0
Detector Location [ft]	0.0	0.0	0.0	0.0	0.0	0.0	0.0	0.0	0.0	0.0	0.0	0.0
Detector Length [ft]	20.0	20.0	0.0	0.0	0.0	0.0	20.0	20.0	0.0	20.0	20.0	0.0
I, Upstream Filtering Factor	1.00	1.00	1.00	1.00	1.00	1.00	1.00	1.00	1.00	1.00	1.00	1.00

**Phasing & Timing: Pattern 1**

Split [s]	9	30	0	10	31	0	12	111	0	9	108	0
Lead / Lag	Lead	-	-	Lead	-	-	Lead	-	-	Lead	-	-
Minimum Green [s]	5	10	0	5	10	0	5	10	0	5	10	0
Vehicle Extension [s]	3.0	3.0	0.0	3.0	3.0	0.0	3.0	3.0	0.0	3.0	3.0	0.0
Minimum Recall	No	No		No	No		No	No		No	No	
Maximum Recall	No	No		No	No		No	No		No	No	
Pedestrian Recall	No	No		No	No		No	No		No	No	

**Exclusive Pedestrian Phase**

Pedestrian Signal Group	0
Pedestrian Walk [s]	0
Pedestrian Clearance [s]	0



**Lane Group Calculations**

Lane Group	L	C	L	C	R	L	C	R	L	C	R
C, Cycle Length [s]	160	160	160	160	160	160	160	160	160	160	160
L, Total Lost Time per Cycle [s]	4.00	4.00	4.00	4.00	4.00	4.00	4.00	4.00	4.00	4.00	4.00
l1_p, Permitted Start-Up Lost Time [s]	0.00	0.00	0.00	0.00	0.00	0.00	0.00	0.00	0.00	0.00	0.00
l2, Clearance Lost Time [s]	2.00	2.00	2.00	2.00	2.00	2.00	2.00	2.00	2.00	2.00	2.00
g_i, Effective Green Time [s]	0	33	5	38	38	0	106	106	0	106	106
g / C, Green / Cycle	0.00	0.20	0.03	0.24	0.24	0.00	0.66	0.66	0.00	0.66	0.66
(v / s)_i Volume / Saturation Flow Rate	0.00	0.01	0.03	0.00	0.00	0.00	0.09	0.00	0.00	0.54	0.01
s, saturation flow rate [veh/h]	1781	1589	1781	1870	1589	1781	3560	1589	1781	3560	1589
c, Capacity [veh/h]	1	325	61	445	378	1	2354	1051	1	2354	1051
d1, Uniform Delay [s]	0.00	50.97	76.80	0.00	46.55	0.00	10.09	0.00	0.00	20.19	9.28
k, delay calibration	0.11	0.50	0.13	0.50	0.50	0.11	0.11	0.11	0.11	0.11	0.11
l, Upstream Filtering Factor	1.00	1.00	1.00	1.00	1.00	1.00	1.00	1.00	1.00	1.00	1.00
d2, Incremental Delay [s]	0.00	0.14	21.86	0.00	0.01	0.00	0.03	0.00	0.00	0.76	0.00
d3, Initial Queue Delay [s]	0.00	0.00	0.00	0.00	0.00	0.00	0.00	0.00	0.00	0.00	0.00
Rp, platoon ratio	1.00	1.00	1.00	1.00	1.00	1.00	1.00	1.00	1.00	1.00	1.00
PF, progression factor	1.00	1.00	1.00	1.00	1.00	1.00	1.00	1.00	1.00	1.00	1.00

**Lane Group Results**

X, volume / capacity	0.00	0.02	0.77	0.00	0.00	0.00	0.13	0.00	0.00	0.82	0.01
d, Delay for Lane Group [s/veh]	0.00	51.11	98.66	0.00	46.56	0.00	10.12	0.00	0.00	20.95	9.28
Lane Group LOS	A	D	F	A	D	A	B	A	A	C	A
Critical Lane Group	No	Yes	Yes	No	No	No	No	No	No	Yes	No
50th-Percentile Queue Length [veh/ln]	0.00	0.27	2.30	0.00	0.03	0.00	2.10	0.00	0.00	26.13	0.15
50th-Percentile Queue Length [ft/ln]	0.00	6.85	57.59	0.00	0.81	0.00	52.47	0.00	0.00	653.14	3.71
95th-Percentile Queue Length [veh/ln]	0.00	0.49	4.15	0.00	0.06	0.00	3.78	0.00	0.00	34.51	0.27
95th-Percentile Queue Length [ft/ln]	0.00	12.33	103.67	0.00	1.46	0.00	94.44	0.00	0.00	862.70	6.68



**Movement, Approach, & Intersection Results**

d_M, Delay for Movement [s/veh]	0.00	51.11	51.11	98.66	0.00	46.56	0.00	10.12	0.00	0.00	20.95	9.28
Movement LOS	A	D	D	F	A	D	A	B	A	A	C	A
d_A, Approach Delay [s/veh]	51.11			97.58			10.12			20.88		
Approach LOS	D			F			B			C		
d_I, Intersection Delay [s/veh]	21.12											
Intersection LOS	C											
Intersection V/C	0.622											

**Emissions**

Vehicle Miles Traveled [mph]	0.00	0.68	11.07	0.00	0.24	0.00	96.48	0.00	0.00	45.97	0.28
Stops [stops/h]	0.00	6.16	51.79	0.00	0.73	0.00	94.36	0.00	0.00	1174.62	3.34
Fuel consumption [US gal/h]	0.00	0.15	1.69	0.00	0.02	0.00	5.14	0.00	0.00	16.64	0.05
CO [g/h]	0.00	10.16	117.81	0.00	1.62	0.00	359.11	0.00	0.00	1163.13	3.69
NOx [g/h]	0.00	1.98	22.92	0.00	0.32	0.00	69.87	0.00	0.00	226.30	0.72
VOC [g/h]	0.00	2.36	27.30	0.00	0.38	0.00	83.23	0.00	0.00	269.57	0.86

**Other Modes**

g_Walk,mi, Effective Walk Time [s]	9.0	9.0	9.0	9.0
M_corner, Corner Circulation Area [ft <sup>2</sup> /ped]	0.00	0.00	0.00	0.00
M_CW, Crosswalk Circulation Area [ft <sup>2</sup> /ped]	0.00	0.00	0.00	0.00
d_p, Pedestrian Delay [s]	71.32	71.32	71.32	71.32
I_p,int, Pedestrian LOS Score for Intersectio	1.971	2.174	2.936	2.858
Crosswalk LOS	A	B	C	C
s_b, Saturation Flow Rate of the bicycle lane	2000	2000	2000	2000
c_b, Capacity of the bicycle lane [bicycles/h]	325	337	1336	1299
d_b, Bicycle Delay [s]	56.18	55.35	8.82	9.84
I_b,int, Bicycle LOS Score for Intersection	1.573	1.639	1.818	3.168
Bicycle LOS	A	A	A	C

**Sequence**

Ring 1	1	2	3	4	-	-	-	-	-	-	-	-	-	-	-
Ring 2	5	6	7	8	-	-	-	-	-	-	-	-	-	-	-
Ring 3	-	-	-	-	-	-	-	-	-	-	-	-	-	-	-
Ring 4	-	-	-	-	-	-	-	-	-	-	-	-	-	-	-

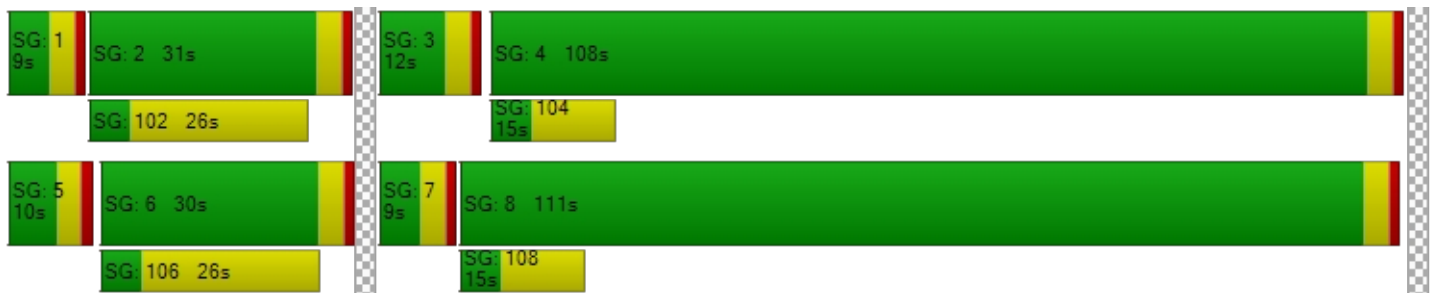



Vistro File: H:\...\PacVest\_20240329.vistro  
 Report File: H:\...\CumulativePM\_LOS.pdf

Scenario 8 Cumulative PM  
 3/29/2024

**Intersection Analysis Summary**

ID	Intersection Name	Control Type	Method	Worst Mvmt	V/C	Delay (s/veh)	LOS
1	Hacienda Drive & Dublin Boulevard	Signalized	HCM 7th Edition	EB Left	0.668	46.0	D
2	Tassajara Road & Central Parkway	Signalized	HCM 7th Edition	EB Thru	0.781	48.7	D
3	Tassajara Road & Dublin Boulevard	Signalized	HCM 7th Edition	NB Right	1.348	144.3	F
4	Tassajara Road & I-580 WB Ramps	Signalized	HCM 7th Edition	WB Left	0.814	15.5	B
5	Santa Rita Rd & I-580 EB Ramps/Pimlico Dr	Signalized	HCM 7th Edition	SB Left	0.967	48.3	D
6	Tassajara Road & Fallon Road	Signalized	HCM 7th Edition	WB Left	0.519	18.0	B
7	Fallon Road & Positano Parkway	Signalized	HCM 7th Edition	SB Left	0.707	16.6	B
8	Fallon Road & Central Parkway	Signalized	HCM 7th Edition	SB Left	0.607	25.8	C
9	Fallon Road & Dublin Boulevard	Signalized	HCM 7th Edition	EB Left	0.741	48.1	D
10	Fallon Road & Fallon Gateway	Signalized	HCM 7th Edition	NB Left	0.477	10.7	B
11	Fallon Road & I-580 WB Ramps	Signalized	HCM 7th Edition	NB Thru	0.751	61.5	E
12	El Charro Road & I-580 EB Ramps	Signalized	HCM 7th Edition	EB Right	0.790	8.5	A
13	El Charro Road & Jack London Boulevard	Signalized	HCM 7th Edition	NB Right	0.784	31.1	C
14	Central Parkway & Sunset View Drive	Signalized	HCM 7th Edition	SB Left	0.262	11.4	B
15	Central Parkway & Panorama Drive/Pino Grande Road	All-way stop	HCM 7th Edition	EB Left	0.147	8.1	A
16	Airway Boulevard & N. Canyons Parkway	Signalized	HCM 7th Edition	EB Right	1.185	145.0	F
17	Airway Boulevard & I-580 WB Ramps	Signalized	HCM 7th Edition	WB Left	0.361	7.9	A
	Creek Road & Central Parkway		HCM 7th Edition				



Version 2024 (SP 0-1)

20	Croak Road & Central Parkway	All-way stop	HCM 7th Edition	EB Left	0.591	13.5	B
22	Croak Road & Dublin Boulevard	Signalized	HCM 7th Edition	WB Left	0.637	18.8	B

V/C, Delay, LOS: For two-way stop, these values are taken from the movement with the worst (highest) delay value. For all other control types, they are taken for the whole intersection.

**Intersection Level Of Service Report**  
**Intersection 1: Hacienda Drive & Dublin Boulevard**

Control Type:	Signalized	Delay (sec / veh):	46.0
Analysis Method:	HCM 7th Edition	Level Of Service:	D
Analysis Period:	15 minutes	Volume to Capacity (v/c):	0.668

**Intersection Setup**

Name	Hacienda Drive			Hacienda Drive			Dublin Boulevard			Dublin Boulevard		
Approach	Northbound			Southbound			Eastbound			Westbound		
Lane Configuration	[Diagram]			[Diagram]			[Diagram]			[Diagram]		
Turning Movement	Left	Thru	Right	Left	Thru	Right	Left	Thru	Right	Left	Thru	Right
Lane Width [ft]	12.00	12.00	12.00	12.00	12.00	12.00	12.00	12.00	12.00	12.00	12.00	12.00
No. of Lanes in Entry Pocket	2	0	2	2	0	1	2	0	2	2	0	0
Entry Pocket Length [ft]	250.00	100.00	380.00	300.00	100.00	220.00	300.00	100.00	250.00	275.00	100.00	100.00
No. of Lanes in Exit Pocket	0	0	0	0	0	0	0	0	0	0	0	1
Exit Pocket Length [ft]	0.00	0.00	0.00	0.00	0.00	0.00	0.00	0.00	0.00	0.00	0.00	1000.00
Speed [mph]	35.00			35.00			40.00			40.00		
Grade [%]	0.00			0.00			0.00			0.00		
Curb Present	Yes			Yes			Yes			Yes		
Crosswalk	Yes			Yes			Yes			Yes		



**Volumes**

Name	Hacienda Drive			Hacienda Drive			Dublin Boulevard			Dublin Boulevard		
Base Volume Input [veh/h]	365	1081	323	55	504	60	259	1027	538	216	649	24
Base Volume Adjustment Factor	1.0000	1.0000	1.0000	1.0000	1.0000	1.0000	1.0000	1.0000	1.0000	1.0000	1.0000	1.0000
Heavy Vehicles Percentage [%]	0.00	0.20	0.80	0.00	0.20	5.10	1.90	1.10	1.50	1.30	1.60	0.00
Proportion of CAVs [%]	0.00											
Growth Factor	1.0000	1.0000	1.0000	1.0000	1.0000	1.0000	1.0000	1.0000	1.0000	1.0000	1.0000	1.0000
In-Process Volume [veh/h]	0	0	0	0	0	0	0	0	0	0	0	0
Site-Generated Trips [veh/h]	0	0	0	0	0	0	0	0	0	0	0	0
Diverted Trips [veh/h]	0	0	0	0	0	0	0	0	0	0	0	0
Pass-by Trips [veh/h]	0	0	0	0	0	0	0	0	0	0	0	0
Existing Site Adjustment Volume [veh/h]	0	0	0	0	0	0	0	0	0	0	0	0
Other Volume [veh/h]	0	0	0	0	0	0	0	0	0	0	0	0
Right Turn on Red Volume [veh/h]	0	0	0	0	0	0	0	0	0	0	0	0
Total Hourly Volume [veh/h]	365	1081	323	55	504	60	259	1027	538	216	649	24
Peak Hour Factor	0.9400	0.9400	0.9400	0.9400	0.9400	0.9400	0.9400	0.9400	0.9400	0.9400	0.9400	0.9400
Other Adjustment Factor	1.0000	1.0000	1.0000	1.0000	1.0000	1.0000	1.0000	1.0000	1.0000	1.0000	1.0000	1.0000
Total 15-Minute Volume [veh/h]	97	288	86	15	134	16	69	273	143	57	173	6
Total Analysis Volume [veh/h]	388	1150	344	59	536	64	276	1093	572	230	690	26
Presence of On-Street Parking	No		No	No		No	No		No	No		No
On-Street Parking Maneuver Rate [/h]	0	0	0	0	0	0	0	0	0	0	0	0
Local Bus Stopping Rate [/h]	0	0	0	0	0	0	0	0	0	0	0	0
v_do, Outbound Pedestrian Volume crossing	5			2			4			2		
v_di, Inbound Pedestrian Volume crossing m	4			2			5			2		
v_co, Outbound Pedestrian Volume crossing	6			1			2			7		
v_ci, Inbound Pedestrian Volume crossing mi	7			2			1			6		
v_ab, Corner Pedestrian Volume [ped/h]	0			0			0			0		
Bicycle Volume [bicycles/h]	1			0			4			1		



**Intersection Settings**

Located in CBD	No
Signal Coordination Group	-
Cycle Length [s]	150
Active Pattern	Pattern 1
Coordination Type	Time of Day Pattern Coordinated
Actuation Type	Fully actuated
Offset [s]	113.0
Offset Reference	Lead Green - Beginning of First Green
Permissive Mode	SingleBand
Lost time [s]	12.00

**Phasing & Timing (Basic)**

Control Type	Protecte	Permiss	Permiss	Protecte	Permiss	Permiss	Protecte	Permiss	Permiss	Protecte	Permiss	Permiss
Signal Group	3	8	0	7	4	0	5	2	0	1	6	0
Auxiliary Signal Groups												
Maximum Green [s]	20	50	0	20	50	0	20	60	0	20	60	0
Amber [s]	3.5	4.5	0.0	3.5	4.1	0.0	3.5	4.5	0.0	3.5	4.5	0.0
All red [s]	1.5	1.5	0.0	1.0	1.5	0.0	1.0	1.5	0.0	1.0	1.5	0.0
Walk [s]	0	4	0	0	4	0	0	4	0	0	4	0
Pedestrian Clearance [s]	0	32	0	0	40	0	0	43	0	0	35	0
Delayed Vehicle Green [s]	0.0	0.0	0.0	0.0	0.0	0.0	0.0	0.0	0.0	0.0	0.0	0.0
Rest In Walk		No			No			No			No	
I1, Start-Up Lost Time [s]	2.0	2.0	0.0	2.0	2.0	0.0	2.0	2.0	0.0	2.0	2.0	0.0
I2, Clearance Lost Time [s]	2.0	2.0	0.0	2.0	2.0	0.0	2.0	2.0	0.0	2.0	2.0	0.0
Detector Location [ft]	0.0	0.0	0.0	0.0	0.0	0.0	0.0	0.0	0.0	0.0	0.0	0.0
Detector Length [ft]	20.0	20.0	0.0	20.0	20.0	0.0	20.0	20.0	0.0	20.0	20.0	0.0
I, Upstream Filtering Factor	1.00	1.00	1.00	1.00	1.00	1.00	1.00	1.00	1.00	1.00	1.00	1.00

**Phasing & Timing: Pattern 1**

Split [s]	18	55	0	14	51	0	15	61	0	20	66	0
Lead / Lag	Lead	-	-	Lead	-	-	Lead	-	-	Lead	-	-
Minimum Green [s]	4	10	0	4	10	0	4	10	0	8	10	0
Vehicle Extension [s]	3.0	3.5	0.0	3.0	3.5	0.0	3.0	3.5	0.0	3.0	3.5	0.0
Minimum Recall	No	No		No	No		No	Yes		No	Yes	
Maximum Recall	No	No		No	No		No	No		No	No	
Pedestrian Recall	No	No		No	No		No	No		No	No	

**Exclusive Pedestrian Phase**

Pedestrian Signal Group	0
Pedestrian Walk [s]	0
Pedestrian Clearance [s]	0



**Lane Group Calculations**

Lane Group	L	C	R	L	C	R	L	C	R	L	C	C
C, Cycle Length [s]	150	150	150	150	150	150	150	150	150	150	150	150
L, Total Lost Time per Cycle [s]	4.00	4.00	4.00	4.00	4.00	4.00	4.00	4.00	4.00	4.00	4.00	4.00
l1_p, Permitted Start-Up Lost Time [s]	0.00	0.00	0.00	0.00	0.00	0.00	0.00	0.00	0.00	0.00	0.00	0.00
l2, Clearance Lost Time [s]	2.00	2.00	2.00	2.00	2.00	2.00	2.00	2.00	2.00	2.00	2.00	2.00
g_i, Effective Green Time [s]	14	54	54	5	44	44	11	63	63	13	65	65
g / C, Green / Cycle	0.09	0.36	0.36	0.03	0.30	0.30	0.07	0.42	0.42	0.08	0.43	0.43
(v / s)_i Volume / Saturation Flow Rate	0.07	0.32	0.12	0.02	0.10	0.04	0.08	0.21	0.21	0.07	0.13	0.13
s, saturation flow rate [veh/h]	5271	3612	2774	3514	5167	1545	3461	5131	2767	3478	3572	1838
c, Capacity [veh/h]	489	1285	987	112	1523	455	255	2165	1168	292	1543	794
d1, Uniform Delay [s]	66.70	45.71	35.45	71.59	41.66	38.95	69.55	31.87	31.45	67.48	27.90	27.92
k, delay calibration	0.11	0.13	0.13	0.11	0.13	0.13	0.11	0.50	0.50	0.11	0.50	0.50
l, Upstream Filtering Factor	1.00	1.00	1.00	1.00	1.00	1.00	1.00	1.00	1.00	1.00	1.00	1.00
d2, Incremental Delay [s]	2.95	2.93	0.25	3.83	0.17	0.17	51.07	0.84	1.47	4.75	0.51	1.00
d3, Initial Queue Delay [s]	0.00	0.00	0.00	0.00	0.00	0.00	0.00	0.00	0.00	0.00	0.00	0.00
Rp, platoon ratio	1.00	1.00	1.00	1.00	1.00	1.00	1.00	1.00	1.00	1.00	1.00	1.00
PF, progression factor	1.00	1.00	1.00	1.00	1.00	1.00	1.00	1.00	1.00	1.00	1.00	1.00

**Lane Group Results**

X, volume / capacity	0.79	0.89	0.35	0.53	0.35	0.14	1.08	0.50	0.49	0.79	0.31	0.31
d, Delay for Lane Group [s/veh]	69.65	48.64	35.71	75.42	41.83	39.12	120.61	32.71	32.92	72.23	28.41	28.92
Lane Group LOS	E	D	D	E	D	D	F	C	C	E	C	C
Critical Lane Group	No	Yes	No	Yes	No	No	No	Yes	No	Yes	No	No
50th-Percentile Queue Length [veh/ln]	4.98	20.53	4.68	1.18	5.26	1.77	6.67	9.78	7.69	4.49	5.64	5.94
50th-Percentile Queue Length [ft/ln]	124.52	513.13	116.88	29.44	131.48	44.37	166.82	244.57	192.13	112.15	141.10	148.59
95th-Percentile Queue Length [veh/ln]	8.64	27.96	8.22	2.12	9.02	3.19	11.19	14.91	12.23	7.96	9.54	9.94
95th-Percentile Queue Length [ft/ln]	216.02	698.88	205.53	53.00	225.51	79.86	279.87	372.81	305.80	198.99	238.51	248.54



**Movement, Approach, & Intersection Results**

d_M, Delay for Movement [s/veh]	69.65	48.64	35.71	75.42	41.83	39.12	120.61	32.71	32.92	72.23	28.57	28.92
Movement LOS	E	D	D	E	D	D	F	C	C	E	C	C
d_A, Approach Delay [s/veh]	50.61			44.58			45.27			39.20		
Approach LOS	D			D			D			D		
d_I, Intersection Delay [s/veh]	45.98											
Intersection LOS	D											
Intersection V/C	0.668											

**Emissions**

Vehicle Miles Traveled [mph]	39.37	116.70	34.91	6.87	62.39	7.45	31.55	124.93	65.38	202.24	415.11	214.48
Stops [stops/h]	358.42	984.67	224.28	56.50	378.46	42.57	320.12	703.97	368.69	215.21	270.77	142.57
Fuel consumption [US gal/h]	9.70	23.24	5.52	1.59	9.79	1.11	11.05	18.67	9.80	12.74	20.26	10.52
CO [g/h]	677.71	1624.16	385.62	111.29	684.08	77.83	772.25	1304.78	684.70	890.44	1416.09	735.27
NOx [g/h]	131.86	316.00	75.03	21.65	133.10	15.14	150.25	253.86	133.22	173.25	275.52	143.06
VOC [g/h]	157.07	376.42	89.37	25.79	158.54	18.04	178.98	302.40	158.69	206.37	328.19	170.41

**Other Modes**

g_Walk,mi, Effective Walk Time [s]	8.0		8.0		8.0		8.0	
M_corner, Corner Circulation Area [ft <sup>2</sup> /ped]	0.00		0.00		0.00		0.00	
M_CW, Crosswalk Circulation Area [ft <sup>2</sup> /ped]	29.41		1155.25		1469.99		110.37	
d_p, Pedestrian Delay [s]	67.25		67.25		67.25		67.25	
I_p,int, Pedestrian LOS Score for Intersectio	3.359		3.052		3.393		3.148	
Crosswalk LOS	C		C		C		C	
s_b, Saturation Flow Rate of the bicycle lane	2000		2000		2000		2000	
c_b, Capacity of the bicycle lane [bicycles/h]	653		605		733		800	
d_b, Bicycle Delay [s]	34.06		36.51		30.18		27.05	
I_b,int, Bicycle LOS Score for Intersection	3.112		1.922		2.627		2.080	
Bicycle LOS	C		A		B		B	

**Sequence**

Ring 1	1	2	3	4	-	-	-	-	-	-	-	-	-	-	-
Ring 2	5	6	7	8	-	-	-	-	-	-	-	-	-	-	-
Ring 3	-	-	-	-	-	-	-	-	-	-	-	-	-	-	-
Ring 4	-	-	-	-	-	-	-	-	-	-	-	-	-	-	-

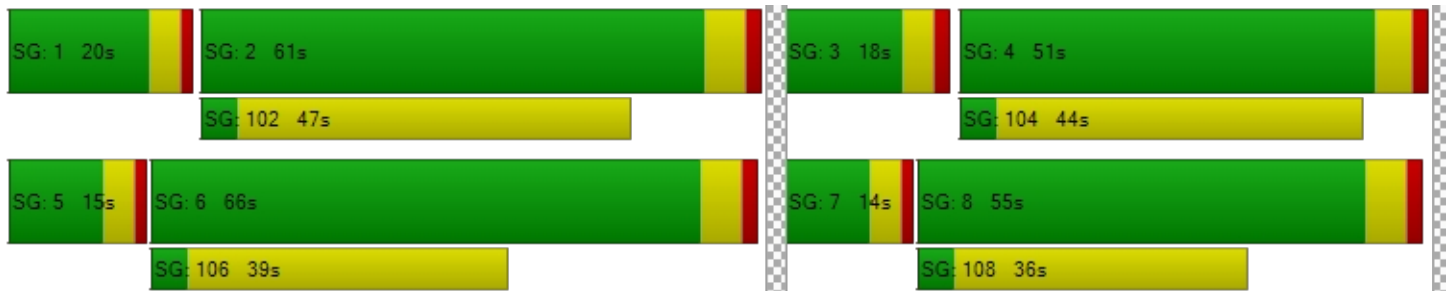

**Intersection Level Of Service Report**  
**Intersection 2: Tassajara Road & Central Parkway**

Control Type:	Signalized	Delay (sec / veh):	48.7
Analysis Method:	HCM 7th Edition	Level Of Service:	D
Analysis Period:	15 minutes	Volume to Capacity (v/c):	0.781

**Intersection Setup**

Name	Tassajara Road			Tassajara Road			Central Parkway			Central Parkway		
Approach	Northbound			Southbound			Eastbound			Westbound		
Lane Configuration	⇐   ⇐			⇐   ⇐			⇐  ⇐			⇐  ⇐		
Turning Movement	Left	Thru	Right	Left	Thru	Right	Left	Thru	Right	Left	Thru	Right
Lane Width [ft]	12.00	12.00	12.00	12.00	12.00	12.00	12.00	12.00	12.00	12.00	12.00	12.00
No. of Lanes in Entry Pocket	1	0	1	1	0	1	1	0	1	2	0	0
Entry Pocket Length [ft]	325.00	100.00	325.00	300.00	100.00	215.00	225.00	100.00	225.00	300.00	100.00	100.00
No. of Lanes in Exit Pocket	0	0	0	0	0	0	0	0	0	0	0	0
Exit Pocket Length [ft]	0.00	0.00	0.00	0.00	0.00	0.00	0.00	0.00	0.00	0.00	0.00	0.00
Speed [mph]	40.00			40.00			35.00			35.00		
Grade [%]	0.00			0.00			0.00			0.00		
Curb Present	Yes			Yes			Yes			Yes		
Crosswalk	Yes			Yes			Yes			Yes		





**Volumes**

Name	Tassajara Road			Tassajara Road			Central Parkway			Central Parkway		
Base Volume Input [veh/h]	68	912	204	34	969	42	69	501	226	213	111	23
Base Volume Adjustment Factor	1.0000	1.0000	1.0000	1.0000	1.0000	1.0000	1.0000	1.0000	1.0000	1.0000	1.0000	1.0000
Heavy Vehicles Percentage [%]	0.00	0.10	0.00	0.00	0.60	0.00	0.00	0.00	0.00	0.00	0.00	0.00
Proportion of CAVs [%]	0.00											
Growth Factor	1.0000	1.0000	1.0000	1.0000	1.0000	1.0000	1.0000	1.0000	1.0000	1.0000	1.0000	1.0000
In-Process Volume [veh/h]	0	0	0	0	0	0	0	0	0	0	0	0
Site-Generated Trips [veh/h]	0	0	0	0	0	0	0	0	0	0	0	0
Diverted Trips [veh/h]	0	0	0	0	0	0	0	0	0	0	0	0
Pass-by Trips [veh/h]	0	0	0	0	0	0	0	0	0	0	0	0
Existing Site Adjustment Volume [veh/h]	0	0	0	0	0	0	0	0	0	0	0	0
Other Volume [veh/h]	0	0	0	0	0	0	0	0	0	0	0	0
Right Turn on Red Volume [veh/h]	0	0	0	0	0	0	0	0	0	0	0	0
Total Hourly Volume [veh/h]	68	912	204	34	969	42	69	501	226	213	111	23
Peak Hour Factor	0.8900	0.8900	0.8900	0.8900	0.8900	0.8900	0.8900	0.8900	0.8900	0.8900	0.8900	0.8900
Other Adjustment Factor	1.0000	1.0000	1.0000	1.0000	1.0000	1.0000	1.0000	1.0000	1.0000	1.0000	1.0000	1.0000
Total 15-Minute Volume [veh/h]	19	256	57	10	272	12	19	141	63	60	31	6
Total Analysis Volume [veh/h]	76	1025	229	38	1089	47	78	563	254	239	125	26
Presence of On-Street Parking	No		No	No		No	No		No	No		No
On-Street Parking Maneuver Rate [/h]	0	0	0	0	0	0	0	0	0	0	0	0
Local Bus Stopping Rate [/h]	0	0	0	0	0	0	0	0	0	0	0	0
v_do, Outbound Pedestrian Volume crossing	2			1			2			0		
v_di, Inbound Pedestrian Volume crossing m	2			0			2			1		
v_co, Outbound Pedestrian Volume crossing	0			4			5			0		
v_ci, Inbound Pedestrian Volume crossing mi	0			5			4			0		
v_ab, Corner Pedestrian Volume [ped/h]	0			0			0			0		
Bicycle Volume [bicycles/h]	1			1			0			0		



**Intersection Settings**

Located in CBD	No
Signal Coordination Group	-
Cycle Length [s]	130
Active Pattern	Pattern 1
Coordination Type	Time of Day Pattern Coordinated
Actuation Type	Fully actuated
Offset [s]	124.0
Offset Reference	Lead Green - Beginning of First Green
Permissive Mode	SingleBand
Lost time [s]	12.00

**Phasing & Timing (Basic)**

Control Type	Protecte	Permiss	Permiss	Protecte	Permiss	Permiss	Protecte	Permiss	Permiss	Protecte	Permiss	Permiss
Signal Group	3	8	0	7	4	0	5	2	0	1	6	0
Auxiliary Signal Groups												
Maximum Green [s]	20	40	0	20	40	0	20	20	0	20	20	0
Amber [s]	3.5	4.3	0.0	3.5	4.3	0.0	3.5	4.1	0.0	3.5	4.1	0.0
All red [s]	1.0	1.0	0.0	1.0	1.0	0.0	1.0	1.0	0.0	1.0	1.0	0.0
Walk [s]	0	4	0	0	4	0	0	4	0	0	4	0
Pedestrian Clearance [s]	0	20	0	0	24	0	0	36	0	0	30	0
Delayed Vehicle Green [s]	0.0	0.0	0.0	0.0	0.0	0.0	0.0	0.0	0.0	0.0	0.0	0.0
Rest In Walk		No			No			No			No	
I1, Start-Up Lost Time [s]	2.0	2.0	0.0	2.0	2.0	0.0	2.0	2.0	0.0	2.0	2.0	0.0
I2, Clearance Lost Time [s]	2.5	3.3	0.0	2.5	3.3	0.0	2.5	3.1	0.0	2.5	3.1	0.0
Detector Location [ft]	0.0	0.0	0.0	0.0	0.0	0.0	0.0	0.0	0.0	0.0	0.0	0.0
Detector Length [ft]	20.0	20.0	0.0	20.0	20.0	0.0	20.0	20.0	0.0	20.0	20.0	0.0
I, Upstream Filtering Factor	1.00	1.00	1.00	1.00	1.00	1.00	1.00	1.00	1.00	1.00	1.00	1.00

**Phasing & Timing: Pattern 1**

Split [s]	18	48	0	18	48	0	18	45	0	19	46	0
Lead / Lag	Lead	-	-	Lead	-	-	Lead	-	-	Lead	-	-
Minimum Green [s]	13	12	0	13	12	0	13	13	0	14	13	0
Vehicle Extension [s]	2.5	4.0	0.0	2.5	4.0	0.0	2.5	2.5	0.0	2.5	2.5	0.0
Minimum Recall	No	Yes		No	Yes		No	No		No	No	
Maximum Recall	No	No		No	No		No	No		No	No	
Pedestrian Recall	No	No		No	No		No	No		No	No	

**Exclusive Pedestrian Phase**

Pedestrian Signal Group	0
Pedestrian Walk [s]	0
Pedestrian Clearance [s]	0



**Lane Group Calculations**

Lane Group	L	C	R	L	C	R	L	C	R	L	C
C, Cycle Length [s]	130	130	130	130	130	130	130	130	130	130	130
L, Total Lost Time per Cycle [s]	4.50	5.30	5.30	4.50	5.30	5.30	4.50	5.10	5.10	4.50	5.10
l1_p, Permitted Start-Up Lost Time [s]	0.00	0.00	0.00	0.00	0.00	0.00	0.00	0.00	0.00	0.00	0.00
l2, Clearance Lost Time [s]	2.50	3.30	3.30	2.50	3.30	3.30	2.50	3.10	3.10	2.50	3.10
g_i, Effective Green Time [s]	12	47	47	10	44	44	12	40	40	14	42
g / C, Green / Cycle	0.09	0.36	0.36	0.07	0.34	0.34	0.09	0.31	0.31	0.11	0.32
(v / s)_i Volume / Saturation Flow Rate	0.04	0.28	0.14	0.02	0.30	0.03	0.04	0.30	0.16	0.07	0.08
s, saturation flow rate [veh/h]	1810	3615	1581	1810	3600	1560	1810	1900	1609	3514	1844
c, Capacity [veh/h]	169	1305	571	135	1231	534	170	584	495	378	592
d1, Uniform Delay [s]	55.74	37.06	30.94	56.85	40.35	28.99	55.75	44.29	36.99	55.53	32.62
k, delay calibration	0.08	0.50	0.50	0.08	0.50	0.50	0.08	0.40	0.08	0.08	0.08
l, Upstream Filtering Factor	1.00	1.00	1.00	1.00	1.00	1.00	1.00	1.00	1.00	1.00	1.00
d2, Incremental Delay [s]	1.38	4.82	2.10	0.83	9.47	0.33	1.43	25.67	0.61	1.30	0.17
d3, Initial Queue Delay [s]	0.00	0.00	0.00	0.00	0.00	0.00	0.00	0.00	0.00	0.00	0.00
Rp, platoon ratio	1.00	1.00	1.00	1.00	1.00	1.00	1.00	1.00	1.00	1.00	1.00
PF, progression factor	1.00	1.00	1.00	1.00	1.00	1.00	1.00	1.00	1.00	1.00	1.00

**Lane Group Results**

X, volume / capacity	0.45	0.79	0.40	0.28	0.88	0.09	0.46	0.96	0.51	0.63	0.26
d, Delay for Lane Group [s/veh]	57.12	41.88	33.03	57.68	49.82	29.31	57.18	69.97	37.60	56.82	32.79
Lane Group LOS	E	D	C	E	D	C	E	E	D	E	C
Critical Lane Group	Yes	No	No	No	Yes	No	No	Yes	No	Yes	No
50th-Percentile Queue Length [veh/ln]	2.40	15.00	5.60	1.20	17.57	1.04	2.48	21.67	6.68	3.80	3.55
50th-Percentile Queue Length [ft/ln]	59.92	375.06	140.08	29.97	439.27	25.94	62.01	541.87	167.01	95.02	88.64
95th-Percentile Queue Length [veh/ln]	4.31	21.35	9.49	2.16	24.45	1.87	4.47	29.31	10.92	6.84	6.38
95th-Percentile Queue Length [ft/ln]	107.85	533.86	237.13	53.94	611.13	46.69	111.63	732.75	272.98	171.04	159.55



**Movement, Approach, & Intersection Results**

d_M, Delay for Movement [s/veh]	57.12	41.88	33.03	57.68	49.82	29.31	57.18	69.97	37.60	56.82	32.79	32.79
Movement LOS	E	D	C	E	D	C	E	E	D	E	C	C
d_A, Approach Delay [s/veh]	41.22			49.25			59.67			47.52		
Approach LOS	D			D			E			D		
d_I, Intersection Delay [s/veh]	48.72											
Intersection LOS	D											
Intersection V/C	0.781											

**Emissions**

Vehicle Miles Traveled [mph]	21.92	295.60	66.04	7.23	207.16	8.94	10.26	74.09	33.43	32.41	20.48
Stops [stops/h]	66.37	830.91	155.16	33.20	973.17	28.73	68.69	600.24	185.00	210.51	98.19
Fuel consumption [US gal/h]	2.32	27.49	5.43	1.03	28.02	0.88	1.82	15.35	4.61	5.58	2.53
CO [g/h]	162.20	1921.21	379.50	72.07	1958.58	61.71	126.89	1073.19	322.15	390.17	176.60
NOx [g/h]	31.56	373.80	73.84	14.02	381.07	12.01	24.69	208.80	62.68	75.91	34.36
VOC [g/h]	37.59	445.26	87.95	16.70	453.92	14.30	29.41	248.72	74.66	90.43	40.93

**Other Modes**

g_Walk,mi, Effective Walk Time [s]	8.0		8.0		8.0		8.0	
M_corner, Corner Circulation Area [ft <sup>2</sup> /ped]	0.00		0.00		0.00		0.00	
M_CW, Crosswalk Circulation Area [ft <sup>2</sup> /ped]	808.01		5330.70		497.66		0.00	
d_p, Pedestrian Delay [s]	57.24		57.24		57.24		57.24	
I_p,int, Pedestrian LOS Score for Intersectio	3.218		2.971		2.476		2.498	
Crosswalk LOS	C		C		B		B	
s_b, Saturation Flow Rate of the bicycle lane	2000		2000		2000		2000	
c_b, Capacity of the bicycle lane [bicycles/h]	657		657		614		629	
d_b, Bicycle Delay [s]	29.33		29.33		31.22		30.53	
I_b,int, Bicycle LOS Score for Intersection	2.657		2.528		3.036		2.203	
Bicycle LOS	B		B		C		B	

**Sequence**

Ring 1	1	2	3	4	-	-	-	-	-	-	-	-	-	-	-
Ring 2	5	6	7	8	-	-	-	-	-	-	-	-	-	-	-
Ring 3	-	-	-	-	-	-	-	-	-	-	-	-	-	-	-
Ring 4	-	-	-	-	-	-	-	-	-	-	-	-	-	-	-

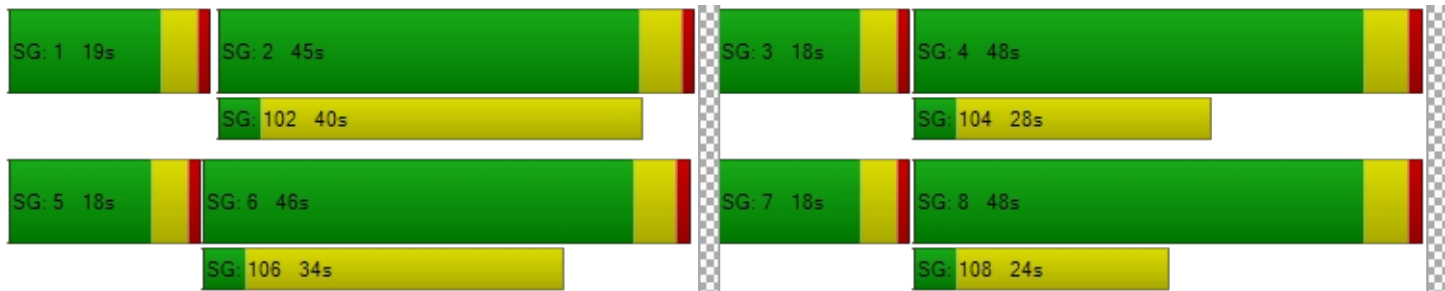

**Intersection Level Of Service Report**  
**Intersection 3: Tassajara Road & Dublin Boulevard**

Control Type:	Signalized	Delay (sec / veh):	144.3
Analysis Method:	HCM 7th Edition	Level Of Service:	F
Analysis Period:	15 minutes	Volume to Capacity (v/c):	1.348

**Intersection Setup**

Name	Tassajara Road			Tassajara Road			Dublin Boulevard			Dublin Boulevard		
Approach	Northbound			Southbound			Eastbound			Westbound		
Lane Configuration	[Diagram]			[Diagram]			[Diagram]			[Diagram]		
Turning Movement	Left	Thru	Right	Left	Thru	Right	Left	Thru	Right	Left	Thru	Right
Lane Width [ft]	12.00	12.00	12.00	12.00	12.00	12.00	12.00	12.00	12.00	12.00	12.00	12.00
No. of Lanes in Entry Pocket	3	0	1	2	0	2	2	0	2	3	0	0
Entry Pocket Length [ft]	380.00	100.00	250.00	295.00	100.00	290.00	265.00	100.00	330.00	395.00	100.00	100.00
No. of Lanes in Exit Pocket	0	0	1	0	0	0	0	0	0	0	0	0
Exit Pocket Length [ft]	0.00	0.00	49.21	0.00	0.00	0.00	0.00	0.00	0.00	0.00	0.00	0.00
Speed [mph]	30.00			40.00			40.00			40.00		
Grade [%]	0.00			0.00			0.00			0.00		
Curb Present	Yes			Yes			Yes			Yes		
Crosswalk	Yes			Yes			Yes			Yes		



**Volumes**

Name	Tassajara Road			Tassajara Road			Dublin Boulevard			Dublin Boulevard		
Base Volume Input [veh/h]	303	781	1021	318	1076	125	259	775	469	848	485	44
Base Volume Adjustment Factor	1.0000	1.0000	1.0000	1.0000	1.0000	1.0000	1.0000	1.0000	1.0000	1.0000	1.0000	1.0000
Heavy Vehicles Percentage [%]	0.70	0.00	0.00	1.20	0.40	0.00	0.40	0.80	13.00	0.20	1.30	0.00
Proportion of CAVs [%]	0.00											
Growth Factor	1.0000	1.0000	1.0000	1.0000	1.0000	1.0000	1.0000	1.0000	1.0000	1.0000	1.0000	1.0000
In-Process Volume [veh/h]	0	0	0	0	0	0	0	0	0	0	0	0
Site-Generated Trips [veh/h]	0	0	0	0	0	0	0	0	0	0	0	0
Diverted Trips [veh/h]	0	0	0	0	0	0	0	0	0	0	0	0
Pass-by Trips [veh/h]	0	0	0	0	0	0	0	0	0	0	0	0
Existing Site Adjustment Volume [veh/h]	0	0	0	0	0	0	0	0	0	0	0	0
Other Volume [veh/h]	0	0	0	0	0	0	0	0	0	0	0	0
Right Turn on Red Volume [veh/h]	0	0	0	0	0	0	0	0	0	0	0	0
Total Hourly Volume [veh/h]	303	781	1021	318	1076	125	259	775	469	848	485	44
Peak Hour Factor	0.9100	0.9100	0.9100	0.9100	0.9100	0.9100	0.9100	0.9100	0.9100	0.9100	0.9100	0.9100
Other Adjustment Factor	1.0000	1.0000	1.0000	1.0000	1.0000	1.0000	1.0000	1.0000	1.0000	1.0000	1.0000	1.0000
Total 15-Minute Volume [veh/h]	83	215	280	87	296	34	71	213	129	233	133	12
Total Analysis Volume [veh/h]	333	858	1122	349	1182	137	285	852	515	932	533	48
Presence of On-Street Parking	No		No	No		No	No		No	No		No
On-Street Parking Maneuver Rate [/h]	0	0	0	0	0	0	0	0	0	0	0	0
Local Bus Stopping Rate [/h]	0	0	0	0	0	0	0	0	0	0	0	0
v_do, Outbound Pedestrian Volume crossing	0			2			3			0		
v_di, Inbound Pedestrian Volume crossing m	0			3			2			0		
v_co, Outbound Pedestrian Volume crossing	0			4			0			3		
v_ci, Inbound Pedestrian Volume crossing mi	0			3			0			4		
v_ab, Corner Pedestrian Volume [ped/h]	0			0			0			0		
Bicycle Volume [bicycles/h]	1			0			1			0		



**Intersection Settings**

Located in CBD	No
Signal Coordination Group	-
Cycle Length [s]	90
Active Pattern	Free Running (No Pattern)
Coordination Type	<i>Free Running</i>
Actuation Type	<i>Fully actuated</i>
Offset [s]	0.0
Offset Reference	Lead Green - Beginning of First Green
Permissive Mode	SingleBand
Lost time [s]	12.00

**Phasing & Timing (Basic)**

Control Type	Protecte	Permiss	Permiss	Protecte	Permiss	Permiss	Protecte	Permiss	Overlap	Protecte	Permiss	Permiss
Signal Group	3	8	0	7	4	0	5	2	2	1	6	0
Auxiliary Signal Groups									2,3			
Maximum Green [s]	20	35	0	20	35	0	20	35	35	20	35	0
Amber [s]	3.5	4.5	0.0	3.5	4.5	0.0	3.5	4.5	4.5	3.5	4.5	0.0
All red [s]	1.5	1.5	0.0	1.5	1.5	0.0	1.5	1.5	1.5	1.5	1.5	0.0
Walk [s]	0	4	0	0	4	0	0	0	0	0	4	0
Pedestrian Clearance [s]	0	29	0	0	42	0	0	0	0	0	42	0
Delayed Vehicle Green [s]	0.0	0.0	0.0	0.0	0.0	0.0	0.0	0.0	0.0	0.0	0.0	0.0
Rest In Walk		No			No			No			No	
I1, Start-Up Lost Time [s]	2.0	2.0	0.0	2.0	2.0	0.0	2.0	2.0	2.0	2.0	2.0	0.0
I2, Clearance Lost Time [s]	2.0	2.0	0.0	2.0	2.0	0.0	2.0	2.0	2.0	2.0	2.0	0.0
Detector Location [ft]	0.0	0.0	0.0	0.0	0.0	0.0	0.0	0.0	0.0	0.0	0.0	0.0
Detector Length [ft]	20.0	20.0	0.0	20.0	20.0	0.0	20.0	20.0	20.0	20.0	20.0	0.0
I, Upstream Filtering Factor	1.00	1.00	1.00	1.00	1.00	1.00	1.00	1.00	1.00	1.00	1.00	1.00

**Phasing & Timing: Free Running (No Pattern)**

Split [s]	0	0	0	0	0	0	0	0	0	0	0	0
Lead / Lag	Lead	-	-	Lead	-	-	Lead	-	-	Lead	-	-
Minimum Green [s]	16	15	0	15	15	0	16	16	16	16	15	0
Vehicle Extension [s]	2.0	4.0	0.0	2.0	4.0	0.0	2.0	3.0	3.0	2.0	3.0	0.0
Minimum Recall	No	Yes		No	Yes		No	No	No	No	No	
Maximum Recall	No	No		No	No		No	No	No	No	No	
Pedestrian Recall	No	No		No	No		No	No	No	No	No	

**Exclusive Pedestrian Phase**

Pedestrian Signal Group	0
Pedestrian Walk [s]	0
Pedestrian Clearance [s]	0



**Lane Group Calculations**

Lane Group	L	C	R	L	C	R	L	C	R	L	C	C
C, Cycle Length [s]	125	125	125	125	125	125	125	125	125	125	125	125
L, Total Lost Time per Cycle [s]	4.00	4.00	4.00	4.00	4.00	4.00	4.00	4.00	4.00	4.00	4.00	4.00
l1_p, Permitted Start-Up Lost Time [s]	0.00	0.00	0.00	0.00	0.00	0.00	0.00	0.00	0.00	0.00	0.00	0.00
l2, Clearance Lost Time [s]	2.00	2.00	2.00	2.00	2.00	2.00	2.00	2.00	0.00	2.00	2.00	2.00
g_i, Effective Green Time [s]	20	37	37	16	33	33	17	35	59	21	38	38
g / C, Green / Cycle	0.16	0.30	0.30	0.13	0.26	0.26	0.14	0.28	0.47	0.17	0.31	0.31
(v / s)_i Volume / Saturation Flow Rate	0.06	0.24	0.70	0.10	0.17	0.05	0.08	0.24	0.20	0.18	0.16	0.16
s, saturation flow rate [veh/h]	5242	3618	1594	3481	6879	2842	3503	3595	2545	5263	1880	1824
c, Capacity [veh/h]	853	1074	473	449	1810	748	479	997	1181	886	581	564
d1, Uniform Delay [s]	46.68	40.41	43.61	52.57	40.87	35.55	50.57	42.67	22.40	51.85	35.28	35.35
k, delay calibration	0.04	0.15	0.50	0.04	0.15	0.15	0.04	0.11	0.11	0.04	0.13	0.13
l, Upstream Filtering Factor	1.00	1.00	1.00	1.00	1.00	1.00	1.00	1.00	1.00	1.00	1.00	1.00
d2, Incremental Delay [s]	0.11	2.01	623.21	1.11	0.57	0.17	0.44	2.21	0.25	26.18	0.81	0.88
d3, Initial Queue Delay [s]	0.00	0.00	0.00	0.00	0.00	0.00	0.00	0.00	0.00	0.00	0.00	0.00
Rp, platoon ratio	1.00	1.00	1.00	1.00	1.00	1.00	1.00	1.00	1.00	1.00	1.00	1.00
PF, progression factor	1.00	1.00	1.00	1.00	1.00	1.00	1.00	1.00	1.00	1.00	1.00	1.00

**Lane Group Results**

X, volume / capacity	0.39	0.80	2.37	0.78	0.65	0.18	0.59	0.85	0.44	1.05	0.51	0.51
d, Delay for Lane Group [s/veh]	46.79	42.42	666.81	53.68	41.45	35.72	51.01	44.88	22.65	78.03	36.09	36.22
Lane Group LOS	D	D	F	D	D	D	D	D	C	F	D	D
Critical Lane Group	No	No	Yes	Yes	No	No	No	Yes	No	Yes	No	No
50th-Percentile Queue Length [veh/ln]	3.10	12.35	96.29	5.27	7.98	1.61	4.15	12.41	4.94	11.18	7.28	7.16
50th-Percentile Queue Length [ft/ln]	77.53	308.87	2407.33	131.71	199.41	40.28	103.63	310.25	123.62	279.55	182.10	179.04
95th-Percentile Queue Length [veh/ln]	5.58	18.12	153.16	9.03	12.61	2.90	7.46	18.19	8.59	17.08	11.71	11.55
95th-Percentile Queue Length [ft/ln]	139.55	452.99	3829.07	225.81	315.21	72.50	186.53	454.68	214.79	426.95	292.76	288.76





**Movement, Approach, & Intersection Results**

d_M, Delay for Movement [s/veh]	46.79	42.42	666.81	53.68	41.45	35.72	51.01	44.88	22.65	78.03	36.15	36.22
Movement LOS	D	D	F	D	D	D	D	D	C	F	D	D
d_A, Approach Delay [s/veh]	345.93			43.54			39.01			61.95		
Approach LOS	F			D			D			E		
d_I, Intersection Delay [s/veh]	144.27											
Intersection LOS	F											
Intersection V/C	1.348											

**Emissions**

Vehicle Miles Traveled [mph]	68.31	176.00	230.16	100.65	340.87	39.51	250.61	749.18	452.85	1121.34	353.04	345.99
Stops [stops/h]	268.87	714.12	2782.90	304.51	922.09	93.12	239.60	717.30	285.81	969.49	210.51	206.97
Fuel consumption [US gal/h]	7.47	18.60	177.06	10.41	31.24	3.33	14.29	41.66	21.40	64.49	16.87	16.55
CO [g/h]	521.98	1299.88	12376.7	727.56	2183.49	232.48	998.79	2912.32	1496.08	4507.70	1179.13	1156.59
NOx [g/h]	101.56	252.91	2408.06	141.56	424.83	45.23	194.33	566.63	291.08	877.03	229.42	225.03
VOC [g/h]	120.97	301.26	2868.43	168.62	506.05	53.88	231.48	674.96	346.73	1044.70	273.28	268.05

**Other Modes**

g_Walk,mi, Effective Walk Time [s]	-6.0		8.0		8.0		8.0	
M_corner, Corner Circulation Area [ft <sup>2</sup> /ped]	0.00		0.00		0.00		0.00	
M_CW, Crosswalk Circulation Area [ft <sup>2</sup> /ped]	0.00		0.00		0.00		0.00	
d_p, Pedestrian Delay [s]	68.43		54.54		54.54		54.54	
I_p,int, Pedestrian LOS Score for Intersectio	3.475		3.356		3.250		3.366	
Crosswalk LOS	C		C		C		C	
s_b, Saturation Flow Rate of the bicycle lane	2000		2000		2000		2000	
c_b, Capacity of the bicycle lane [bicycles/h]	562		562		562		562	
d_b, Bicycle Delay [s]	32.22		32.20		32.22		32.20	
I_b,int, Bicycle LOS Score for Intersection	3.468		2.248		2.923		2.808	
Bicycle LOS	C		B		C		C	

**Sequence**

Ring 1	1	2	3	4	-	-	-	-	-	-	-	-	-	-	-
Ring 2	5	6	7	8	-	-	-	-	-	-	-	-	-	-	-
Ring 3	-	-	-	-	-	-	-	-	-	-	-	-	-	-	-
Ring 4	-	-	-	-	-	-	-	-	-	-	-	-	-	-	-



**Intersection Level Of Service Report**  
**Intersection 4: Tassajara Road & I-580 WB Ramps**

Control Type:	Signalized	Delay (sec / veh):	15.5
Analysis Method:	HCM 7th Edition	Level Of Service:	B
Analysis Period:	15 minutes	Volume to Capacity (v/c):	0.814

**Intersection Setup**

Name	Tassajara Road		Tassajara Road		I-580 WB Ramps	
Approach	Northbound		Southbound		Westbound	
Lane Configuration	↑↑		↑↑↑		↔↔↔↔	
Turning Movement	Thru	Right	Left	Thru	Left	Right
Lane Width [ft]	12.00	12.00	12.00	12.00	12.00	12.00
No. of Lanes in Entry Pocket	0	0	0	0	1	1
Entry Pocket Length [ft]	100.00	100.00	100.00	100.00	100.00	100.00
No. of Lanes in Exit Pocket	0	1	0	0	0	0
Exit Pocket Length [ft]	0.00	49.21	0.00	0.00	0.00	0.00
Speed [mph]	30.00		30.00		30.00	
Grade [%]	0.00		0.00		0.00	
Curb Present	No		No		No	
Crosswalk	Yes		Yes		Yes	



**Volumes**

Name	Tassajara Road		Tassajara Road		I-580 WB Ramps	
Base Volume Input [veh/h]	2047	0	0	1759	489	260
Base Volume Adjustment Factor	1.0000	1.0000	1.0000	1.0000	1.0000	1.0000
Heavy Vehicles Percentage [%]	0.40	2.00	2.00	0.80	0.40	1.70
Proportion of CAVs [%]	0.00					
Growth Factor	1.0000	1.0000	1.0000	1.0000	1.0000	1.0000
In-Process Volume [veh/h]	0	0	0	0	0	0
Site-Generated Trips [veh/h]	0	0	0	0	0	0
Diverted Trips [veh/h]	0	0	0	0	0	0
Pass-by Trips [veh/h]	0	0	0	0	0	0
Existing Site Adjustment Volume [veh/h]	0	0	0	0	0	0
Other Volume [veh/h]	0	0	0	0	0	0
Right Turn on Red Volume [veh/h]	0	0	0	0	0	0
Total Hourly Volume [veh/h]	2047	0	0	1759	489	260
Peak Hour Factor	0.9600	1.0000	1.0000	0.9600	0.9600	0.9600
Other Adjustment Factor	1.0000	1.0000	1.0000	1.0000	1.0000	1.0000
Total 15-Minute Volume [veh/h]	533	0	0	458	127	68
Total Analysis Volume [veh/h]	2132	0	0	1832	509	271
Presence of On-Street Parking	No	No	No	No	No	No
On-Street Parking Maneuver Rate [/h]	0	0	0	0	0	0
Local Bus Stopping Rate [/h]	0	0	0	0	0	0
v_do, Outbound Pedestrian Volume crossing	0		0		0	
v_di, Inbound Pedestrian Volume crossing m	0		0		0	
v_co, Outbound Pedestrian Volume crossing	0		0		0	
v_ci, Inbound Pedestrian Volume crossing mi	0		0		0	
v_ab, Corner Pedestrian Volume [ped/h]	0		0		0	
Bicycle Volume [bicycles/h]	1		0		0	



**Intersection Settings**

Located in CBD	No
Signal Coordination Group	-
Cycle Length [s]	60
Active Pattern	Pattern 1
Coordination Type	Time of Day Pattern Coordinated
Actuation Type	Fully actuated
Offset [s]	29.0
Offset Reference	Beginning of First Yellow
Permissive Mode	SingleBand
Lost time [s]	6.00

**Phasing & Timing (Basic)**

Control Type	Permissive	Permissive	Permissive	Permissive	Permissive	Permissive
Signal Group	6	0	0	2	4	0
Auxiliary Signal Groups						
Maximum Green [s]	40	0	0	40	20	0
Amber [s]	4.9	0.0	0.0	4.9	4.4	0.0
All red [s]	1.0	0.0	0.0	1.0	1.0	0.0
Walk [s]	5	0	0	0	0	0
Pedestrian Clearance [s]	16	0	0	0	0	0
Delayed Vehicle Green [s]	0.0	0.0	0.0	0.0	0.0	0.0
Rest In Walk	No			No	No	
I1, Start-Up Lost Time [s]	2.0	0.0	0.0	2.0	2.0	0.0
I2, Clearance Lost Time [s]	3.9	0.0	0.0	3.9	3.4	0.0
Detector Location [ft]	0.0	0.0	0.0	0.0	0.0	0.0
Detector Length [ft]	20.0	0.0	0.0	20.0	20.0	0.0
I, Upstream Filtering Factor	1.00	1.00	1.00	1.00	1.00	1.00

**Phasing & Timing: Pattern 1**

Split [s]	36	0	0	36	24	0
Lead / Lag	-	-	-	-	Lead	-
Minimum Green [s]	7	0	0	7	4	0
Vehicle Extension [s]	3.0	0.0	0.0	3.0	2.0	0.0
Minimum Recall	No			No	No	
Maximum Recall	Yes			Yes	No	
Pedestrian Recall	Yes			No	No	

**Exclusive Pedestrian Phase**

Pedestrian Signal Group	0
Pedestrian Walk [s]	0
Pedestrian Clearance [s]	0



**Lane Group Calculations**

Lane Group	C	C	L	R
C, Cycle Length [s]	63	63	63	63
L, Total Lost Time per Cycle [s]	5.90	5.90	5.40	5.40
l1_p, Permitted Start-Up Lost Time [s]	0.00	0.00	0.00	0.00
l2, Clearance Lost Time [s]	3.90	3.90	3.40	3.40
g_i, Effective Green Time [s]	40	40	12	12
g / C, Green / Cycle	0.63	0.63	0.19	0.19
(v / s)_i Volume / Saturation Flow Rate	0.59	0.36	0.15	0.10
s, saturation flow rate [veh/h]	3606	5143	3503	2820
c, Capacity [veh/h]	2281	3253	661	532
d1, Uniform Delay [s]	10.45	6.63	24.34	23.02
k, delay calibration	0.50	0.50	0.04	0.04
l, Upstream Filtering Factor	1.00	1.00	1.00	1.00
d2, Incremental Delay [s]	8.71	0.71	0.72	0.28
d3, Initial Queue Delay [s]	0.00	0.00	0.00	0.00
Rp, platoon ratio	1.00	1.00	1.00	1.00
PF, progression factor	1.00	1.00	1.00	1.00

**Lane Group Results**

X, volume / capacity	0.93	0.56	0.77	0.51
d, Delay for Lane Group [s/veh]	19.16	7.34	25.07	23.30
Lane Group LOS	B	A	C	C
Critical Lane Group	Yes	No	Yes	No
50th-Percentile Queue Length [veh/ln]	12.04	3.59	3.45	1.72
50th-Percentile Queue Length [ft/ln]	300.90	89.71	86.27	43.11
95th-Percentile Queue Length [veh/ln]	17.73	6.46	6.21	3.10
95th-Percentile Queue Length [ft/ln]	443.14	161.47	155.29	77.61

**Movement, Approach, & Intersection Results**

d_M, Delay for Movement [s/veh]	19.16	0.00	0.00	7.34	25.07	23.30
Movement LOS	B			A	C	C
d_A, Approach Delay [s/veh]	19.16		7.34		24.45	
Approach LOS	B		A		C	
d_I, Intersection Delay [s/veh]	15.47					
Intersection LOS	B					
Intersection V/C	0.814					

**Emissions**

Vehicle Miles Traveled [mph]	359.00	375.80	41.16	21.92
Stops [stops/h]	1371.43	613.29	393.21	196.50
Fuel consumption [US gal/h]	30.67	21.60	6.46	3.27
CO [g/h]	2143.73	1509.63	451.82	228.78
NOx [g/h]	417.09	293.72	87.91	44.51
VOC [g/h]	496.83	349.87	104.71	53.02

**Other Modes**

g_Walk,mi, Effective Walk Time [s]	18.6	18.6	9.0
M_corner, Corner Circulation Area [ft <sup>2</sup> /ped]	0.00	0.00	0.00
M_CW, Crosswalk Circulation Area [ft <sup>2</sup> /ped]	0.00	0.00	0.00
d_p, Pedestrian Delay [s]	15.73	15.73	23.24
I_p,int, Pedestrian LOS Score for Intersectio	3.140	3.093	2.435
Crosswalk LOS	C	C	B
s_b, Saturation Flow Rate of the bicycle lane	2000	2000	2000
c_b, Capacity of the bicycle lane [bicycles/h]	953	953	589
d_b, Bicycle Delay [s]	8.67	8.66	15.73
I_b,int, Bicycle LOS Score for Intersection	3.319	2.567	1.560
Bicycle LOS	C	B	A

**Sequence**

Ring 1	-	2	-	4	-	-	-	-	-	-	-	-	-	-	-	-
Ring 2	-	6	-	-	-	-	-	-	-	-	-	-	-	-	-	-
Ring 3	-	-	-	-	-	-	-	-	-	-	-	-	-	-	-	-
Ring 4	-	-	-	-	-	-	-	-	-	-	-	-	-	-	-	-



**Intersection Level Of Service Report**  
**Intersection 5: Santa Rita Rd & I-580 EB Ramps/Pimlico Dr**

Control Type:	Signalized	Delay (sec / veh):	48.3
Analysis Method:	HCM 7th Edition	Level Of Service:	D
Analysis Period:	15 minutes	Volume to Capacity (v/c):	0.967

**Intersection Setup**

Name	Santa Rita Road			Tassajara Road			I-580 EB Ramps			Pimlico Drive		
Approach	Northbound			Southbound			Eastbound			Westbound		
Lane Configuration	↑			↵			↵↑			↵↵↵↑		
Turning Movement	Left	Thru	Right	Left	Thru	Right	Left	Thru	Right	Left	Thru	Right
Lane Width [ft]	12.00	12.00	12.00	12.00	12.00	12.00	12.00	12.00	12.00	12.00	12.00	12.00
No. of Lanes in Entry Pocket	0	0	1	1	0	0	1	0	0	2	0	1
Entry Pocket Length [ft]	100.00	100.00	250.00	425.00	100.00	100.00	625.00	100.00	100.00	200.00	100.00	250.00
No. of Lanes in Exit Pocket	0	0	0	0	0	2	0	0	0	0	0	0
Exit Pocket Length [ft]	0.00	0.00	0.00	0.00	0.00	49.21	0.00	0.00	0.00	0.00	0.00	0.00
Speed [mph]	30.00			30.00			30.00			30.00		
Grade [%]	0.00			0.00			0.00			0.00		
Curb Present	No			No			No			No		
Crosswalk	Yes			No			Yes			Yes		



**Volumes**

Name	Santa Rita Road			Tassajara Road			I-580 EB Ramps			Pimlico Drive		
Base Volume Input [veh/h]	0	2132	85	278	1271	0	699	225	0	112	0	431
Base Volume Adjustment Factor	1.0000	1.0000	1.0000	1.0000	1.0000	1.0000	1.0000	1.0000	1.0000	1.0000	1.0000	1.0000
Heavy Vehicles Percentage [%]	2.00	0.30	1.20	0.40	0.40	2.00	1.20	0.50	2.00	0.00	2.00	0.00
Proportion of CAVs [%]	0.00											
Growth Factor	1.0000	1.0000	1.0000	1.0000	1.0000	1.0000	1.0000	1.0000	1.0000	1.0000	1.0000	1.0000
In-Process Volume [veh/h]	0	0	0	0	0	0	0	0	0	0	0	0
Site-Generated Trips [veh/h]	0	0	0	0	0	0	0	0	0	0	0	0
Diverted Trips [veh/h]	0	0	0	0	0	0	0	0	0	0	0	0
Pass-by Trips [veh/h]	0	0	0	0	0	0	0	0	0	0	0	0
Existing Site Adjustment Volume [veh/h]	0	0	0	0	0	0	0	0	0	0	0	0
Other Volume [veh/h]	0	0	0	0	0	0	0	0	0	0	0	0
Right Turn on Red Volume [veh/h]	0	0	0	0	0	0	0	0	0	0	0	0
Total Hourly Volume [veh/h]	0	2132	85	278	1271	0	699	225	0	112	0	431
Peak Hour Factor	1.0000	0.9600	0.9600	0.9600	0.9600	1.0000	0.9600	0.9600	1.0000	0.9600	1.0000	0.9600
Other Adjustment Factor	1.0000	1.0000	1.0000	1.0000	1.0000	1.0000	1.0000	1.0000	1.0000	1.0000	1.0000	1.0000
Total 15-Minute Volume [veh/h]	0	555	22	72	331	0	182	59	0	29	0	112
Total Analysis Volume [veh/h]	0	2221	89	290	1324	0	728	234	0	117	0	449
Presence of On-Street Parking	No		No	No		No	No		No	No		No
On-Street Parking Maneuver Rate [/h]	0	0	0	0	0	0	0	0	0	0	0	0
Local Bus Stopping Rate [/h]	0	0	0	0	0	0	0	0	0	0	0	0
v_do, Outbound Pedestrian Volume crossing	1			0			0			0		
v_di, Inbound Pedestrian Volume crossing m	0			0			1			0		
v_co, Outbound Pedestrian Volume crossing	0			2			3			1		
v_ci, Inbound Pedestrian Volume crossing mi	1			3			2			0		
v_ab, Corner Pedestrian Volume [ped/h]	0			0			0			0		
Bicycle Volume [bicycles/h]	1			0			0			0		





**Intersection Settings**

Located in CBD	No
Signal Coordination Group	-
Cycle Length [s]	120
Active Pattern	Pattern 1
Coordination Type	Time of Day Pattern Coordinated
Actuation Type	Fully actuated
Offset [s]	13.0
Offset Reference	Lead Green - Beginning of First Green
Permissive Mode	SingleBand
Lost time [s]	12.00

**Phasing & Timing (Basic)**

Control Type	Permiss	Permiss	Permiss	Protecte	Permiss	Permiss	Protecte	Permiss	Permiss	Permiss	Permiss	Overlap
Signal Group	0	6	0	5	2	0	3	8	0	7	0	4
Auxiliary Signal Groups												4,5
Maximum Green [s]	0	30	0	20	30	0	27	20	0	20	0	20
Amber [s]	0.0	4.4	0.0	3.0	4.4	0.0	4.4	4.4	0.0	3.5	0.0	3.5
All red [s]	0.0	1.0	0.0	1.0	1.0	0.0	1.0	1.0	0.0	1.0	0.0	1.0
Walk [s]	0	5	0	0	5	0	0	5	0	0	0	0
Pedestrian Clearance [s]	0	25	0	0	8	0	0	25	0	0	0	0
Delayed Vehicle Green [s]	0.0	0.0	0.0	0.0	0.0	0.0	0.0	0.0	0.0	0.0	0.0	0.0
Rest In Walk		No			No			No		No		
I1, Start-Up Lost Time [s]	0.0	2.0	0.0	2.0	2.0	0.0	2.0	2.0	0.0	2.0	0.0	2.0
I2, Clearance Lost Time [s]	0.0	3.4	0.0	2.0	3.4	0.0	3.4	3.4	0.0	2.5	0.0	2.5
Detector Location [ft]	0.0	0.0	0.0	0.0	0.0	0.0	0.0	0.0	0.0	0.0	0.0	0.0
Detector Length [ft]	0.0	0.0	0.0	0.0	0.0	0.0	0.0	0.0	0.0	0.0	0.0	0.0
I, Upstream Filtering Factor	1.00	1.00	1.00	1.00	1.00	1.00	1.00	1.00	1.00	1.00	1.00	1.00

**Phasing & Timing: Pattern 1**

Split [s]	0	40	0	28	68	0	32	36	0	16	0	20
Lead / Lag	-	-	-	Lead	-	-	Lead	-	-	Lead	-	-
Minimum Green [s]	0	7	0	5	7	0	5	5	0	5	0	5
Vehicle Extension [s]	0.0	3.0	0.0	3.0	3.0	0.0	3.0	2.0	0.0	3.0	0.0	2.0
Minimum Recall		No		No	No		No	No		No		No
Maximum Recall		Yes		No	Yes		No	No		No		No
Pedestrian Recall		No		No	Yes		No	No		No		No

**Exclusive Pedestrian Phase**

Pedestrian Signal Group	0
Pedestrian Walk [s]	0
Pedestrian Clearance [s]	0



**Lane Group Calculations**

Lane Group	C	C	L	C	L	C	L	R
C, Cycle Length [s]	120	120	120	120	120	120	120	120
L, Total Lost Time per Cycle [s]	5.40	5.40	4.00	5.40	5.40	5.40	4.50	4.00
l1_p, Permitted Start-Up Lost Time [s]	0.00	0.00	0.00	0.00	0.00	0.00	0.00	0.00
l2, Clearance Lost Time [s]	3.40	3.40	2.00	3.40	3.40	3.40	2.50	0.00
g_i, Effective Green Time [s]	46	46	20	70	27	29	6	33
g / C, Green / Cycle	0.38	0.38	0.17	0.58	0.22	0.24	0.05	0.27
(v / s)_i Volume / Saturation Flow Rate	0.40	0.31	0.16	0.37	0.21	0.12	0.03	0.16
s, saturation flow rate [veh/h]	4379	1838	1804	3606	3481	1892	3514	2859
c, Capacity [veh/h]	1679	705	301	2104	771	451	177	777
d1, Uniform Delay [s]	36.96	33.23	49.59	16.43	45.95	39.67	55.92	37.72
k, delay calibration	0.50	0.50	0.40	0.50	0.11	0.16	0.11	0.04
l, Upstream Filtering Factor	1.00	1.00	1.00	1.00	1.00	1.00	1.00	1.00
d2, Incremental Delay [s]	30.61	10.29	38.38	1.44	6.77	1.39	4.18	0.25
d3, Initial Queue Delay [s]	0.00	0.00	0.00	0.00	0.00	0.00	0.00	0.00
Rp, platoon ratio	1.00	1.00	1.00	1.00	1.00	1.00	1.00	1.00
PF, progression factor	1.00	1.00	1.00	1.00	1.00	1.00	1.00	1.00

**Lane Group Results**

X, volume / capacity	1.03	0.82	0.96	0.63	0.94	0.52	0.66	0.58
d, Delay for Lane Group [s/veh]	67.56	43.51	87.97	17.86	52.72	41.06	60.11	37.98
Lane Group LOS	F	D	F	B	D	D	E	D
Critical Lane Group	Yes	No	Yes	No	Yes	No	No	Yes
50th-Percentile Queue Length [veh/ln]	20.79	16.88	11.80	11.92	11.33	6.18	1.84	5.72
50th-Percentile Queue Length [ft/ln]	519.70	422.12	295.09	298.01	283.37	154.41	46.08	143.06
95th-Percentile Queue Length [veh/ln]	28.90	23.62	17.44	17.58	16.86	10.25	3.32	9.65
95th-Percentile Queue Length [ft/ln]	722.44	590.59	435.95	439.57	421.41	256.31	82.94	241.14

**Movement, Approach, & Intersection Results**

d_M, Delay for Movement [s/veh]	0.00	62.27	43.51	87.97	17.86	0.00	52.72	41.06	0.00	60.11	0.00	37.98
Movement LOS		E	D	F	B		D	D		E		D
d_A, Approach Delay [s/veh]	61.55			30.46			49.88			42.55		
Approach LOS	E			C			D			D		
d_I, Intersection Delay [s/veh]	48.32											
Intersection LOS	D											
Intersection V/C	0.967											

**Emissions**

Vehicle Miles Traveled [mph]	170.87	56.96	48.83	222.95	101.02	32.47	9.99	38.32
Stops [stops/h]	1871.80	506.78	354.27	715.57	680.41	185.38	110.64	343.50
Fuel consumption [US gal/h]	41.19	10.26	9.16	17.94	15.73	4.32	2.45	6.95
CO [g/h]	2879.43	717.04	640.17	1254.34	1099.32	301.68	171.48	485.47
NOx [g/h]	560.23	139.51	124.55	244.05	213.89	58.70	33.36	94.45
VOC [g/h]	667.33	166.18	148.36	290.70	254.78	69.92	39.74	112.51

**Other Modes**

g_Walk,mi, Effective Walk Time [s]	9.0	0.0	9.0	9.0
M_corner, Corner Circulation Area [ft <sup>2</sup> /ped]	0.00	0.00	0.00	0.00
M_CW, Crosswalk Circulation Area [ft <sup>2</sup> /ped]	6543.07	0.00	0.00	0.00
d_p, Pedestrian Delay [s]	51.31	0.00	51.31	51.31
I_p,int, Pedestrian LOS Score for Intersectio	3.078	0.000	2.381	2.545
Crosswalk LOS	C	F	B	B
s_b, Saturation Flow Rate of the bicycle lane	2000	2000	2000	2000
c_b, Capacity of the bicycle lane [bicycles/h]	577	1044	510	192
d_b, Bicycle Delay [s]	30.38	13.71	33.28	49.02
I_b,int, Bicycle LOS Score for Intersection	2.512	2.891	3.147	1.560
Bicycle LOS	B	C	C	A

**Sequence**

Ring 1	-	2	3	4	-	-	-	-	-	-	-	-	-	-	-	-
Ring 2	5	6	7	8	-	-	-	-	-	-	-	-	-	-	-	-
Ring 3	-	-	-	-	-	-	-	-	-	-	-	-	-	-	-	-
Ring 4	-	-	-	-	-	-	-	-	-	-	-	-	-	-	-	-

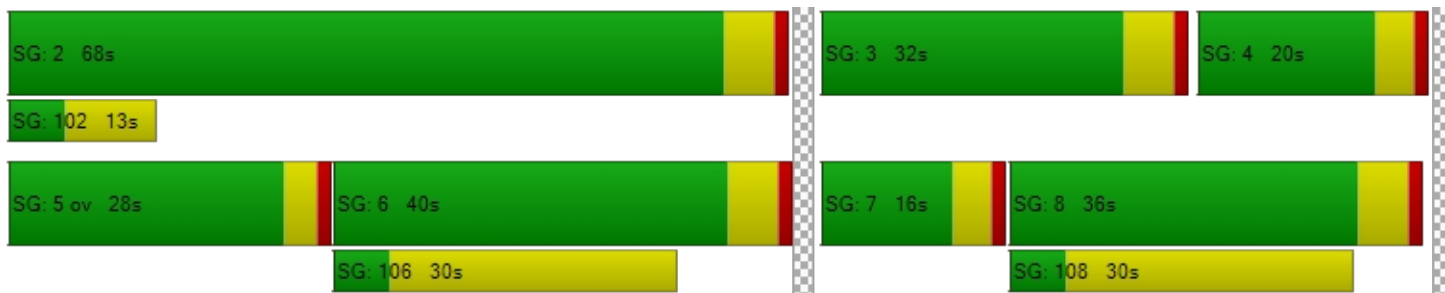

**Intersection Level Of Service Report**  
**Intersection 6: Tassajara Road & Fallon Road**

Control Type:	Signalized	Delay (sec / veh):	18.0
Analysis Method:	HCM 7th Edition	Level Of Service:	B
Analysis Period:	15 minutes	Volume to Capacity (v/c):	0.519

**Intersection Setup**

Name	Fallon Road			Fallon Road			Tassajara Road			Syrah Drive		
Approach	Northbound			Southbound			Eastbound			Westbound		
Lane Configuration												
Turning Movement	Left	Thru	Right	Left	Thru	Right	Left	Thru	Right	Left	Thru	Right
Lane Width [ft]	12.00	12.00	12.00	12.00	12.00	12.00	12.00	12.00	12.00	12.00	12.00	12.00
No. of Lanes in Entry Pocket	1	0	1	1	0	2	1	0	1	1	0	1
Entry Pocket Length [ft]	175.00	100.00	175.00	175.00	100.00	225.00	475.00	100.00	175.00	100.00	100.00	100.00
No. of Lanes in Exit Pocket	0	0	0	0	0	0	0	0	0	0	0	0
Exit Pocket Length [ft]	0.00	0.00	0.00	0.00	0.00	0.00	0.00	0.00	0.00	0.00	0.00	0.00
Speed [mph]	30.00			30.00			30.00			30.00		
Grade [%]	0.00			0.00			0.00			0.00		
Curb Present	No			No			No			No		
Crosswalk	Yes			Yes			Yes			Yes		



**Volumes**

Name	Fallon Road			Fallon Road			Tassajara Road			Syrah Drive		
Base Volume Input [veh/h]	60	318	21	9	535	397	633	34	81	5	17	8
Base Volume Adjustment Factor	1.0000	1.0000	1.0000	1.0000	1.0000	1.0000	1.0000	1.0000	1.0000	1.0000	1.0000	1.0000
Heavy Vehicles Percentage [%]	0.00	0.00	4.80	0.00	2.50	0.30	0.20	0.00	0.00	0.00	0.00	20.00
Proportion of CAVs [%]	0.00											
Growth Factor	1.0000	1.0000	1.0000	1.0000	1.0000	1.0000	1.0000	1.0000	1.0000	1.0000	1.0000	1.0000
In-Process Volume [veh/h]	0	0	0	0	0	0	0	0	0	0	0	0
Site-Generated Trips [veh/h]	0	0	0	0	0	0	0	0	0	0	0	0
Diverted Trips [veh/h]	0	0	0	0	0	0	0	0	0	0	0	0
Pass-by Trips [veh/h]	0	0	0	0	0	0	0	0	0	0	0	0
Existing Site Adjustment Volume [veh/h]	0	0	0	0	0	0	0	0	0	0	0	0
Other Volume [veh/h]	0	0	0	0	0	0	0	0	0	0	0	0
Right Turn on Red Volume [veh/h]	0	0	0	0	0	0	0	0	0	0	0	0
Total Hourly Volume [veh/h]	60	318	21	9	535	397	633	34	81	5	17	8
Peak Hour Factor	0.9200	0.9200	0.9200	0.9200	0.9200	0.9200	0.9200	0.9200	0.9200	0.9200	0.9200	0.9200
Other Adjustment Factor	1.0000	1.0000	1.0000	1.0000	1.0000	1.0000	1.0000	1.0000	1.0000	1.0000	1.0000	1.0000
Total 15-Minute Volume [veh/h]	16	86	6	2	145	108	172	9	22	1	5	2
Total Analysis Volume [veh/h]	65	346	23	10	582	432	688	37	88	5	18	9
Presence of On-Street Parking	No		No	No		No	No		No	No		No
On-Street Parking Maneuver Rate [/h]	0	0	0	0	0	0	0	0	0	0	0	0
Local Bus Stopping Rate [/h]	0	0	0	0	0	0	0	0	0	0	0	0
v_do, Outbound Pedestrian Volume crossing	0			0			0			0		
v_di, Inbound Pedestrian Volume crossing m	0			0			0			0		
v_co, Outbound Pedestrian Volume crossing	0			0			0			0		
v_ci, Inbound Pedestrian Volume crossing mi	0			0			0			0		
v_ab, Corner Pedestrian Volume [ped/h]	0			0			0			0		
Bicycle Volume [bicycles/h]	0			0			0			0		



**Intersection Settings**

Located in CBD	No
Signal Coordination Group	-
Cycle Length [s]	90
Active Pattern	Free Running (No Pattern)
Coordination Type	<i>Free Running</i>
Actuation Type	<i>Fully actuated</i>
Offset [s]	0.0
Offset Reference	Lead Green - Beginning of First Green
Permissive Mode	SingleBand
Lost time [s]	12.00

**Phasing & Timing (Basic)**

Control Type	Protecte	Permiss	Permiss	Protecte	Permiss	Permiss	Protecte	Permiss	Permiss	Protecte	Permiss	Permiss
Signal Group	3	8	0	7	4	0	5	2	0	1	6	0
Auxiliary Signal Groups												
Maximum Green [s]	25	50	0	25	50	0	35	30	0	20	30	0
Amber [s]	3.5	4.8	0.0	3.5	4.8	0.0	3.5	5.0	0.0	3.0	3.6	0.0
All red [s]	1.0	1.0	0.0	1.0	1.0	0.0	1.0	1.0	0.0	1.0	1.0	0.0
Walk [s]	0	4	0	0	0	0	0	4	0	0	3	0
Pedestrian Clearance [s]	0	25	0	0	0	0	0	28	0	0	36	0
Delayed Vehicle Green [s]	0.0	0.0	0.0	0.0	0.0	0.0	0.0	0.0	0.0	0.0	0.0	0.0
Rest In Walk		No			No			No			No	
I1, Start-Up Lost Time [s]	2.0	2.0	0.0	2.0	2.0	0.0	2.0	2.0	0.0	2.0	2.0	0.0
I2, Clearance Lost Time [s]	2.0	2.0	0.0	2.0	2.0	0.0	2.0	2.0	0.0	2.0	2.0	0.0
Detector Location [ft]	0.0	0.0	0.0	0.0	0.0	0.0	0.0	0.0	0.0	0.0	0.0	0.0
Detector Length [ft]	0.0	0.0	0.0	0.0	0.0	0.0	0.0	0.0	0.0	0.0	0.0	0.0
I, Upstream Filtering Factor	1.00	1.00	1.00	1.00	1.00	1.00	1.00	1.00	1.00	1.00	1.00	1.00

**Phasing & Timing: Free Running (No Pattern)**

Split [s]	0	0	0	0	0	0	0	0	0	0	0	0
Lead / Lag	Lead	-	-	Lead	-	-	Lead	-	-	Lead	-	-
Minimum Green [s]	9	10	0	9	10	0	11	8	0	12	9	0
Vehicle Extension [s]	3.0	3.0	0.0	3.0	3.0	0.0	3.0	3.0	0.0	3.0	3.0	0.0
Minimum Recall	No	No		No	No		Yes	No		No	No	
Maximum Recall	No	No		No	No		No	No		No	No	
Pedestrian Recall	No	No		No	No		No	No		No	No	

**Exclusive Pedestrian Phase**

Pedestrian Signal Group	0
Pedestrian Walk [s]	0
Pedestrian Clearance [s]	0



**Lane Group Calculations**

Lane Group	L	C	R	L	C	R	L	C	R	L	C	R
C, Cycle Length [s]	55	55	55	55	55	55	55	55	55	55	55	55
L, Total Lost Time per Cycle [s]	4.00	4.00	4.00	4.00	4.00	4.00	4.00	4.00	4.00	4.00	4.00	4.00
l1_p, Permitted Start-Up Lost Time [s]	0.00	0.00	0.00	0.00	0.00	0.00	0.00	0.00	0.00	0.00	0.00	0.00
l2, Clearance Lost Time [s]	2.00	2.00	2.00	2.00	2.00	2.00	2.00	2.00	2.00	2.00	2.00	2.00
g_i, Effective Green Time [s]	6	19	19	2	15	15	15	17	17	1	4	4
g / C, Green / Cycle	0.11	0.34	0.34	0.03	0.26	0.26	0.26	0.32	0.32	0.02	0.07	0.07
(v / s)_i Volume / Saturation Flow Rate	0.04	0.10	0.01	0.01	0.16	0.15	0.20	0.02	0.05	0.00	0.01	0.01
s, saturation flow rate [veh/h]	1810	3618	1554	1810	3546	2852	3509	1900	1615	1810	1900	1360
c, Capacity [veh/h]	204	1247	536	59	938	754	931	600	510	30	127	91
d1, Uniform Delay [s]	22.49	13.08	12.00	25.93	17.83	17.56	18.50	13.15	13.64	26.73	24.22	24.15
k, delay calibration	0.11	0.11	0.11	0.11	0.11	0.11	0.11	0.11	0.11	0.11	0.11	0.11
l, Upstream Filtering Factor	1.00	1.00	1.00	1.00	1.00	1.00	1.00	1.00	1.00	1.00	1.00	1.00
d2, Incremental Delay [s]	0.88	0.12	0.03	1.34	0.68	0.69	1.17	0.04	0.16	2.67	0.50	0.47
d3, Initial Queue Delay [s]	0.00	0.00	0.00	0.00	0.00	0.00	0.00	0.00	0.00	0.00	0.00	0.00
Rp, platoon ratio	1.00	1.00	1.00	1.00	1.00	1.00	1.00	1.00	1.00	1.00	1.00	1.00
PF, progression factor	1.00	1.00	1.00	1.00	1.00	1.00	1.00	1.00	1.00	1.00	1.00	1.00

**Lane Group Results**

X, volume / capacity	0.32	0.28	0.04	0.17	0.62	0.57	0.74	0.06	0.17	0.17	0.14	0.10
d, Delay for Lane Group [s/veh]	23.37	13.20	12.04	27.27	18.51	18.25	19.67	13.19	13.80	29.40	24.72	24.62
Lane Group LOS	C	B	B	C	B	B	B	B	B	C	C	C
Critical Lane Group	Yes	No	No	No	Yes	No	Yes	No	No	No	Yes	No
50th-Percentile Queue Length [veh/ln]	0.77	1.38	0.17	0.14	2.99	2.20	3.72	0.29	0.73	0.08	0.22	0.11
50th-Percentile Queue Length [ft/ln]	19.21	34.56	4.28	3.53	74.81	54.89	92.93	7.31	18.16	2.07	5.60	2.87
95th-Percentile Queue Length [veh/ln]	1.38	2.49	0.31	0.25	5.39	3.95	6.69	0.53	1.31	0.15	0.40	0.21
95th-Percentile Queue Length [ft/ln]	34.58	62.20	7.70	6.36	134.65	98.81	167.28	13.16	32.68	3.72	10.09	5.16



**Movement, Approach, & Intersection Results**

d_M, Delay for Movement [s/veh]	23.37	13.20	12.04	27.27	18.51	18.25	19.67	13.19	13.80	29.40	24.72	24.62
Movement LOS	C	B	B	C	B	B	B	B	B	C	C	C
d_A, Approach Delay [s/veh]	14.66			18.48			18.74			25.42		
Approach LOS	B			B			B			C		
d_I, Intersection Delay [s/veh]	17.95											
Intersection LOS	B											
Intersection V/C	0.519											

**Emissions**

Vehicle Miles Traveled [mph]	6.19	32.97	2.19	1.09	63.17	46.89	88.72	4.77	11.35	0.18	0.65	0.32
Stops [stops/h]	50.36	181.17	11.21	9.27	392.19	287.80	487.24	19.17	47.60	5.42	14.69	7.52
Fuel consumption [US gal/h]	0.84	3.29	0.21	0.15	6.96	5.13	9.10	0.40	0.98	0.07	0.20	0.10
CO [g/h]	58.88	229.80	14.57	10.58	486.46	358.26	636.03	28.08	68.31	4.70	13.86	6.98
NOx [g/h]	11.46	44.71	2.84	2.06	94.65	69.70	123.75	5.46	13.29	0.91	2.70	1.36
VOC [g/h]	13.65	53.26	3.38	2.45	112.74	83.03	147.41	6.51	15.83	1.09	3.21	1.62

**Other Modes**

g_Walk,mi, Effective Walk Time [s]	8.0			7.0			-5.8			8.0		
M_corner, Corner Circulation Area [ft <sup>2</sup> /ped]	0.00			0.00			0.00			0.00		
M_CW, Crosswalk Circulation Area [ft <sup>2</sup> /ped]	0.00			0.00			0.00			0.00		
d_p, Pedestrian Delay [s]	20.05			20.91			33.57			20.05		
I_p,int, Pedestrian LOS Score for Intersectio	2.611			2.861			2.667			2.133		
Crosswalk LOS	B			C			B			B		
s_b, Saturation Flow Rate of the bicycle lane	2000			2000			2000			2000		
c_b, Capacity of the bicycle lane [bicycles/h]	1820			1820			1092			1092		
d_b, Bicycle Delay [s]	0.22			0.22			5.66			5.66		
I_b,int, Bicycle LOS Score for Intersection	1.918			2.404			2.901			1.612		
Bicycle LOS	A			B			C			A		

**Sequence**

Ring 1	1	2	3	4	-	-	-	-	-	-	-	-	-	-	-
Ring 2	5	6	7	8	-	-	-	-	-	-	-	-	-	-	-
Ring 3	-	-	-	-	-	-	-	-	-	-	-	-	-	-	-
Ring 4	-	-	-	-	-	-	-	-	-	-	-	-	-	-	-





**Intersection Level Of Service Report**  
**Intersection 7: Fallon Road & Positano Parkway**

Control Type:	Signalized	Delay (sec / veh):	16.6
Analysis Method:	HCM 7th Edition	Level Of Service:	B
Analysis Period:	15 minutes	Volume to Capacity (v/c):	0.707

**Intersection Setup**

Name	Fallon Road		Fallon Road		Positano Parkway	
Approach	Northbound		Southbound		Westbound	
Lane Configuration	↑↑↑↔		↔↑↑↑		↔↔↔	
Turning Movement	Thru	Right	Left	Thru	Left	Right
Lane Width [ft]	12.00	12.00	12.00	12.00	12.00	12.00
No. of Lanes in Entry Pocket	0	1	1	0	1	1
Entry Pocket Length [ft]	100.00	225.00	325.00	100.00	375.00	425.00
No. of Lanes in Exit Pocket	0	0	0	0	0	0
Exit Pocket Length [ft]	0.00	0.00	0.00	0.00	0.00	0.00
Speed [mph]	30.00		30.00		30.00	
Grade [%]	0.00		0.00		0.00	
Curb Present	No		No		No	
Crosswalk	Yes		Yes		Yes	



**Volumes**

Name	Fallon Road		Fallon Road		Positano Parkway	
Base Volume Input [veh/h]	503	350	415	683	394	104
Base Volume Adjustment Factor	1.0000	1.0000	1.0000	1.0000	1.0000	1.0000
Heavy Vehicles Percentage [%]	0.20	0.00	0.00	1.50	0.00	0.00
Proportion of CAVs [%]	0.00					
Growth Factor	1.0000	1.0000	1.0000	1.0000	1.0000	1.0000
In-Process Volume [veh/h]	0	0	0	0	0	0
Site-Generated Trips [veh/h]	0	0	0	0	0	0
Diverted Trips [veh/h]	0	0	0	0	0	0
Pass-by Trips [veh/h]	0	0	0	0	0	0
Existing Site Adjustment Volume [veh/h]	0	0	0	0	0	0
Other Volume [veh/h]	0	0	0	0	0	0
Right Turn on Red Volume [veh/h]	0	0	0	0	0	0
Total Hourly Volume [veh/h]	503	350	415	683	394	104
Peak Hour Factor	0.9300	0.9300	0.9300	0.9300	0.9300	0.9300
Other Adjustment Factor	1.0000	1.0000	1.0000	1.0000	1.0000	1.0000
Total 15-Minute Volume [veh/h]	135	94	112	184	106	28
Total Analysis Volume [veh/h]	541	376	446	734	424	112
Presence of On-Street Parking	No	No	No	No	No	No
On-Street Parking Maneuver Rate [/h]	0	0	0	0	0	0
Local Bus Stopping Rate [/h]	0	0	0	0	0	0
v_do, Outbound Pedestrian Volume crossing	0		1		0	
v_di, Inbound Pedestrian Volume crossing m	0		0		1	
v_co, Outbound Pedestrian Volume crossing	0		0		1	
v_ci, Inbound Pedestrian Volume crossing mi	1		0		0	
v_ab, Corner Pedestrian Volume [ped/h]	0		0		0	
Bicycle Volume [bicycles/h]	0		0		0	



**Intersection Settings**

Located in CBD	No
Signal Coordination Group	-
Cycle Length [s]	90
Active Pattern	Free Running (No Pattern)
Coordination Type	<i>Free Running</i>
Actuation Type	<i>Fully actuated</i>
Offset [s]	0.0
Offset Reference	Lead Green - Beginning of First Green
Permissive Mode	SingleBand
Lost time [s]	9.00

**Phasing & Timing (Basic)**

Control Type	Permissive	Permissive	Protected	Permissive	Permissive	Permissive
Signal Group	4	0	7	8	6	0
Auxiliary Signal Groups						
Maximum Green [s]	30	0	20	30	24	0
Amber [s]	4.3	0.0	3.5	4.3	4.0	0.0
All red [s]	1.0	0.0	1.0	1.0	1.0	0.0
Walk [s]	0	0	0	4	4	0
Pedestrian Clearance [s]	0	0	0	20	34	0
Delayed Vehicle Green [s]	0.0	0.0	0.0	0.0	0.0	0.0
Rest In Walk	No			No	No	
I1, Start-Up Lost Time [s]	2.0	0.0	2.0	2.0	2.0	0.0
I2, Clearance Lost Time [s]	2.0	0.0	2.0	2.0	2.0	0.0
Detector Location [ft]	0.0	0.0	0.0	0.0	0.0	0.0
Detector Length [ft]	20.0	0.0	20.0	20.0	20.0	0.0
I, Upstream Filtering Factor	1.00	1.00	1.00	1.00	1.00	1.00

**Phasing & Timing: Free Running (No Pattern)**

Split [s]	14	0	9	14	9	0
Lead / Lag	-	-	Lead	-	Lead	-
Minimum Green [s]	10	0	5	10	5	0
Vehicle Extension [s]	3.0	0.0	3.0	3.0	3.0	0.0
Minimum Recall	Yes		No	Yes	No	
Maximum Recall	No		No	No	No	
Pedestrian Recall	No		No	No	No	

**Exclusive Pedestrian Phase**

Pedestrian Signal Group	0
Pedestrian Walk [s]	0
Pedestrian Clearance [s]	0



**Lane Group Calculations**

Lane Group	C	R	L	C	L	R
C, Cycle Length [s]	59	59	59	59	59	59
L, Total Lost Time per Cycle [s]	4.00	4.00	4.00	4.00	4.00	4.00
l1_p, Permitted Start-Up Lost Time [s]	0.00	0.00	0.00	0.00	0.00	0.00
l2, Clearance Lost Time [s]	2.00	2.00	2.00	2.00	2.00	2.00
g_i, Effective Green Time [s]	19	19	17	40	12	12
g / C, Green / Cycle	0.32	0.32	0.29	0.67	0.19	0.19
(v / s)_i Volume / Saturation Flow Rate	0.10	0.23	0.25	0.14	0.12	0.07
s, saturation flow rate [veh/h]	5167	1615	1810	5114	3514	1613
c, Capacity [veh/h]	1635	511	520	3430	685	314
d1, Uniform Delay [s]	15.53	18.13	20.07	3.77	21.94	20.73
k, delay calibration	0.11	0.11	0.24	0.11	0.11	0.11
l, Upstream Filtering Factor	1.00	1.00	1.00	1.00	1.00	1.00
d2, Incremental Delay [s]	0.12	2.08	8.82	0.03	0.92	0.68
d3, Initial Queue Delay [s]	0.00	0.00	0.00	0.00	0.00	0.00
Rp, platoon ratio	1.00	1.00	1.00	1.00	1.00	1.00
PF, progression factor	1.00	1.00	1.00	1.00	1.00	1.00

**Lane Group Results**

X, volume / capacity	0.33	0.74	0.86	0.21	0.62	0.36
d, Delay for Lane Group [s/veh]	15.65	20.21	28.89	3.80	22.86	21.41
Lane Group LOS	B	C	C	A	C	C
Critical Lane Group	No	Yes	Yes	No	Yes	No
50th-Percentile Queue Length [veh/ln]	1.71	4.41	6.53	0.74	2.59	1.31
50th-Percentile Queue Length [ft/ln]	42.72	110.26	163.22	18.47	64.86	32.78
95th-Percentile Queue Length [veh/ln]	3.08	7.85	10.72	1.33	4.67	2.36
95th-Percentile Queue Length [ft/ln]	76.90	196.36	267.99	33.24	116.76	59.01

**Movement, Approach, & Intersection Results**

d_M, Delay for Movement [s/veh]	15.65	20.21	28.89	3.80	22.86	21.41
Movement LOS	B	C	C	A	C	C
d_A, Approach Delay [s/veh]	17.52		13.28		22.56	
Approach LOS	B		B		C	
d_I, Intersection Delay [s/veh]	16.65					
Intersection LOS	B					
Intersection V/C	0.707					

**Emissions**

Vehicle Miles Traveled [mph]	136.07	94.57	39.13	64.40	50.84	13.43
Stops [stops/h]	310.75	267.34	395.75	134.34	314.54	79.48
Fuel consumption [US gal/h]	9.04	6.92	6.42	3.96	5.80	1.48
CO [g/h]	631.99	483.47	448.74	276.85	405.64	103.46
NOx [g/h]	122.96	94.06	87.31	53.87	78.92	20.13
VOC [g/h]	146.47	112.05	104.00	64.16	94.01	23.98

**Other Modes**

g_Walk,mi, Effective Walk Time [s]	8.0		8.0		8.7	
M_corner, Corner Circulation Area [ft <sup>2</sup> /ped]	0.00		0.00		0.00	
M_CW, Crosswalk Circulation Area [ft <sup>2</sup> /ped]	0.00		0.00		0.00	
d_p, Pedestrian Delay [s]	22.23		22.23		21.63	
I_p,int, Pedestrian LOS Score for Intersectio	2.865		2.831		2.443	
Crosswalk LOS	C		C		B	
s_b, Saturation Flow Rate of the bicycle lane	2000		2000		2000	
c_b, Capacity of the bicycle lane [bicycles/h]	1010		1010		808	
d_b, Bicycle Delay [s]	7.27		7.27		10.54	
I_b,int, Bicycle LOS Score for Intersection	2.064		2.209		1.560	
Bicycle LOS	B		B		A	

**Sequence**

Ring 1	-	-	-	8	-	-	-	-	-	-	-	-	-	-	-	-
Ring 2	-	6	7	4	-	-	-	-	-	-	-	-	-	-	-	-
Ring 3	-	-	-	-	-	-	-	-	-	-	-	-	-	-	-	-
Ring 4	-	-	-	-	-	-	-	-	-	-	-	-	-	-	-	-

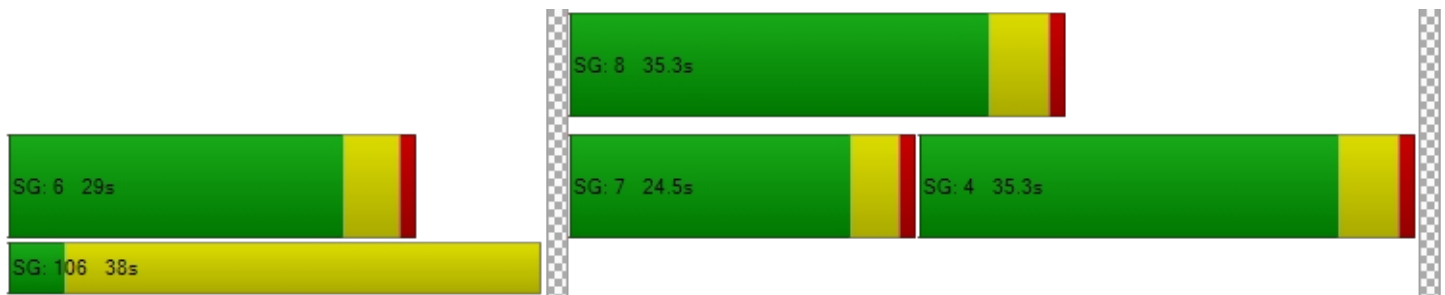

**Intersection Level Of Service Report**  
**Intersection 8: Fallon Road & Central Parkway**

Control Type:	Signalized	Delay (sec / veh):	25.8
Analysis Method:	HCM 7th Edition	Level Of Service:	C
Analysis Period:	15 minutes	Volume to Capacity (v/c):	0.607

**Intersection Setup**

Name	Fallon Road			Fallon Road			Central Parkway			Central Parkway		
Approach	Northbound			Southbound			Eastbound			Westbound		
Lane Configuration												
Turning Movement	Left	Thru	Right	Left	Thru	Right	Left	Thru	Right	Left	Thru	Right
Lane Width [ft]	12.00	12.00	12.00	12.00	12.00	12.00	12.00	12.00	12.00	12.00	12.00	12.00
No. of Lanes in Entry Pocket	2	0	1	1	0	1	2	0	2	2	0	1
Entry Pocket Length [ft]	300.00	100.00	255.00	295.00	100.00	245.00	350.00	100.00	230.00	250.00	100.00	250.00
No. of Lanes in Exit Pocket	0	0	0	0	0	2	0	0	0	0	0	0
Exit Pocket Length [ft]	0.00	0.00	0.00	0.00	0.00	500.00	0.00	0.00	0.00	0.00	0.00	0.00
Speed [mph]	40.00			30.00			25.00			30.00		
Grade [%]	0.00			0.00			0.00			0.00		
Curb Present	Yes			Yes			Yes			Yes		
Crosswalk	Yes			Yes			Yes			Yes		



**Volumes**

Name	Fallon Road			Fallon Road			Central Parkway			Central Parkway		
Base Volume Input [veh/h]	134	846	167	32	1097	120	112	58	287	175	41	35
Base Volume Adjustment Factor	1.0000	1.0000	1.0000	1.0000	1.0000	1.0000	1.0000	1.0000	1.0000	1.0000	1.0000	1.0000
Heavy Vehicles Percentage [%]	0.70	0.10	0.00	0.00	0.40	0.00	0.00	0.00	0.00	0.00	0.00	0.00
Proportion of CAVs [%]	0.00											
Growth Factor	1.0000	1.0000	1.0000	1.0000	1.0000	1.0000	1.0000	1.0000	1.0000	1.0000	1.0000	1.0000
In-Process Volume [veh/h]	0	0	0	0	0	0	0	0	0	0	0	0
Site-Generated Trips [veh/h]	0	0	0	0	0	0	0	0	0	0	0	0
Diverted Trips [veh/h]	0	0	0	0	0	0	0	0	0	0	0	0
Pass-by Trips [veh/h]	0	0	0	0	0	0	0	0	0	0	0	0
Existing Site Adjustment Volume [veh/h]	0	0	0	0	0	0	0	0	0	0	0	0
Other Volume [veh/h]	0	0	0	0	0	0	0	0	0	0	0	0
Right Turn on Red Volume [veh/h]	0	0	0	0	0	0	0	0	0	0	0	0
Total Hourly Volume [veh/h]	134	846	167	32	1097	120	112	58	287	175	41	35
Peak Hour Factor	0.9200	0.9200	0.9200	0.9200	0.9200	0.9200	0.9200	0.9200	0.9200	0.9200	0.9200	0.9200
Other Adjustment Factor	1.0000	1.0000	1.0000	1.0000	1.0000	1.0000	1.0000	1.0000	1.0000	1.0000	1.0000	1.0000
Total 15-Minute Volume [veh/h]	36	230	45	9	298	33	30	16	78	48	11	10
Total Analysis Volume [veh/h]	146	920	182	35	1192	130	122	63	312	190	45	38
Presence of On-Street Parking	No		No	No		No	No		No	No		No
On-Street Parking Maneuver Rate [/h]	0	0	0	0	0	0	0	0	0	0	0	0
Local Bus Stopping Rate [/h]	0	0	0	0	0	0	0	0	0	0	0	0
v_do, Outbound Pedestrian Volume crossing	1			4			4			1		
v_di, Inbound Pedestrian Volume crossing m	1			4			4			1		
v_co, Outbound Pedestrian Volume crossing	2			6			1			5		
v_ci, Inbound Pedestrian Volume crossing mi	1			5			2			6		
v_ab, Corner Pedestrian Volume [ped/h]	0			0			0			0		
Bicycle Volume [bicycles/h]	0			1			0			0		



**Intersection Settings**

Located in CBD	No
Signal Coordination Group	-
Cycle Length [s]	90
Active Pattern	Free Running (No Pattern)
Coordination Type	<i>Free Running</i>
Actuation Type	<i>Fully actuated</i>
Offset [s]	0.0
Offset Reference	Lead Green - Beginning of First Green
Permissive Mode	SingleBand
Lost time [s]	12.00

**Phasing & Timing (Basic)**

Control Type	Protecte	Permiss	Permiss	Protecte	Permiss	Permiss	Protecte	Permiss	Permiss	Protecte	Permiss	Permiss
Signal Group	3	8	0	7	4	0	5	2	0	1	6	0
Auxiliary Signal Groups												
Maximum Green [s]	20	30	0	20	30	0	20	30	0	20	30	0
Amber [s]	3.5	4.3	0.0	3.0	4.3	0.0	3.0	4.0	0.0	3.0	4.0	0.0
All red [s]	1.0	1.0	0.0	1.0	1.0	0.0	1.0	1.0	0.0	1.0	1.0	0.0
Walk [s]	0	4	0	0	4	0	0	4	0	0	4	0
Pedestrian Clearance [s]	0	28	0	0	34	0	0	42	0	0	41	0
Delayed Vehicle Green [s]	0.0	0.0	0.0	0.0	0.0	0.0	0.0	0.0	0.0	0.0	0.0	0.0
Rest In Walk		No			No			No			No	
I1, Start-Up Lost Time [s]	2.0	2.0	0.0	2.0	2.0	0.0	2.0	2.0	0.0	2.0	2.0	0.0
I2, Clearance Lost Time [s]	2.0	2.0	0.0	2.0	2.0	0.0	2.0	2.0	0.0	2.0	2.0	0.0
Detector Location [ft]	0.0	0.0	0.0	0.0	0.0	0.0	0.0	0.0	0.0	0.0	0.0	0.0
Detector Length [ft]	20.0	20.0	0.0	0.0	0.0	0.0	20.0	20.0	0.0	20.0	20.0	0.0
I, Upstream Filtering Factor	1.00	1.00	1.00	1.00	1.00	1.00	1.00	1.00	1.00	1.00	1.00	1.00

**Phasing & Timing: Free Running (No Pattern)**

Split [s]	0	0	0	0	0	0	0	0	0	0	0	0
Lead / Lag	Lead	-	-	Lead	-	-	Lead	-	-	Lead	-	-
Minimum Green [s]	10	12	0	10	12	0	10	12	0	10	12	0
Vehicle Extension [s]	2.0	4.0	0.0	2.0	4.0	0.0	2.0	4.0	0.0	2.0	4.0	0.0
Minimum Recall	No	Yes		No	Yes		No	No		No	No	
Maximum Recall	No	No		No	No		No	No		No	No	
Pedestrian Recall	No	No		No	No		No	No		No	No	

**Exclusive Pedestrian Phase**

Pedestrian Signal Group	0
Pedestrian Walk [s]	0
Pedestrian Clearance [s]	0





**Lane Group Calculations**

Lane Group	L	C	R	L	C	R	L	C	R	L	C	R
C, Cycle Length [s]	85	85	85	85	85	85	85	85	85	85	85	85
L, Total Lost Time per Cycle [s]	4.00	4.00	4.00	4.00	4.00	4.00	4.00	4.00	4.00	4.00	4.00	4.00
l1_p, Permitted Start-Up Lost Time [s]	0.00	0.00	0.00	0.00	0.00	0.00	0.00	0.00	0.00	0.00	0.00	0.00
l2, Clearance Lost Time [s]	2.00	2.00	2.00	2.00	2.00	2.00	2.00	2.00	2.00	2.00	2.00	2.00
g_i, Effective Green Time [s]	10	32	32	6	28	28	9	21	21	10	21	21
g / C, Green / Cycle	0.12	0.38	0.38	0.07	0.33	0.33	0.11	0.25	0.25	0.12	0.25	0.25
(v / s)_i Volume / Saturation Flow Rate	0.04	0.18	0.11	0.02	0.23	0.08	0.03	0.03	0.19	0.05	0.02	0.02
s, saturation flow rate [veh/h]	3495	5172	1611	1810	5159	1583	3514	1900	1609	3514	1900	1594
c, Capacity [veh/h]	421	1964	612	121	1683	516	392	471	399	411	481	403
d1, Uniform Delay [s]	34.22	19.83	18.38	37.62	25.02	20.92	34.64	24.80	29.71	34.94	24.22	24.21
k, delay calibration	0.04	0.15	0.15	0.04	0.15	0.15	0.04	0.15	0.16	0.04	0.15	0.15
l, Upstream Filtering Factor	1.00	1.00	1.00	1.00	1.00	1.00	1.00	1.00	1.00	1.00	1.00	1.00
d2, Incremental Delay [s]	0.18	0.25	0.38	0.48	0.79	0.36	0.17	0.18	5.04	0.30	0.12	0.14
d3, Initial Queue Delay [s]	0.00	0.00	0.00	0.00	0.00	0.00	0.00	0.00	0.00	0.00	0.00	0.00
Rp, platoon ratio	1.00	1.00	1.00	1.00	1.00	1.00	1.00	1.00	1.00	1.00	1.00	1.00
PF, progression factor	1.00	1.00	1.00	1.00	1.00	1.00	1.00	1.00	1.00	1.00	1.00	1.00

**Lane Group Results**

X, volume / capacity	0.35	0.47	0.30	0.29	0.71	0.25	0.31	0.13	0.78	0.46	0.09	0.09
d, Delay for Lane Group [s/veh]	34.40	20.08	18.76	38.11	25.81	21.28	34.81	24.98	34.76	35.24	24.34	24.36
Lane Group LOS	C	C	B	D	C	C	C	C	C	D	C	C
Critical Lane Group	Yes	No	No	No	Yes	No	No	No	Yes	Yes	No	No
50th-Percentile Queue Length [veh/ln]	1.33	4.24	2.37	0.70	6.82	1.88	1.16	1.00	6.37	1.81	0.69	0.59
50th-Percentile Queue Length [ft/ln]	33.28	105.91	59.25	17.40	170.42	47.08	29.01	25.07	159.24	45.29	17.31	14.68
95th-Percentile Queue Length [veh/ln]	2.40	7.61	4.27	1.25	11.10	3.39	2.09	1.81	10.51	3.26	1.25	1.06
95th-Percentile Queue Length [ft/ln]	59.90	190.30	106.64	31.33	277.47	84.74	52.21	45.13	262.71	81.52	31.16	26.42



**Movement, Approach, & Intersection Results**

d_M, Delay for Movement [s/veh]	34.40	20.08	18.76	38.11	25.81	21.28	34.81	24.98	34.76	35.24	24.34	24.36
Movement LOS	C	C	B	D	C	C	C	C	C	D	C	C
d_A, Approach Delay [s/veh]	21.56			25.70			33.53			31.93		
Approach LOS	C			C			C			C		
d_I, Intersection Delay [s/veh]	25.83											
Intersection LOS	C											
Intersection V/C	0.607											

**Emissions**

Vehicle Miles Traveled [mph]	38.66	243.59	48.19	8.80	299.80	32.70	10.66	5.51	27.27	43.19	10.23	8.64
Stops [stops/h]	113.28	540.85	100.85	29.62	870.27	80.13	98.75	42.68	271.05	154.19	29.46	24.99
Fuel consumption [US gal/h]	3.52	17.80	3.41	0.80	23.41	2.35	1.72	0.73	4.47	3.99	0.81	0.68
CO [g/h]	246.01	1244.11	238.47	55.74	1636.44	164.39	120.40	51.14	312.64	279.08	56.39	47.67
NOx [g/h]	47.87	242.06	46.40	10.85	318.39	31.98	23.43	9.95	60.83	54.30	10.97	9.28
VOC [g/h]	57.02	288.33	55.27	12.92	379.26	38.10	27.90	11.85	72.46	64.68	13.07	11.05

**Other Modes**

g_Walk,mi, Effective Walk Time [s]	8.0			8.0			8.0			8.0		
M_corner, Corner Circulation Area [ft <sup>2</sup> /ped]	0.00			0.00			0.00			0.00		
M_CW, Crosswalk Circulation Area [ft <sup>2</sup> /ped]	0.00			0.00			0.00			0.00		
d_p, Pedestrian Delay [s]	34.68			34.68			34.68			34.68		
I_p,int, Pedestrian LOS Score for Intersectio	3.348			3.204			2.688			2.407		
Crosswalk LOS	C			C			B			B		
s_b, Saturation Flow Rate of the bicycle lane	2000			2000			2000			2000		
c_b, Capacity of the bicycle lane [bicycles/h]	709			709			709			709		
d_b, Bicycle Delay [s]	17.62			17.63			17.62			17.62		
I_b,int, Bicycle LOS Score for Intersection	2.246			2.306			2.380			2.010		
Bicycle LOS	B			B			B			B		

**Sequence**

Ring 1	1	2	3	4	-	-	-	-	-	-	-	-	-	-	-
Ring 2	5	6	7	8	-	-	-	-	-	-	-	-	-	-	-
Ring 3	-	-	-	-	-	-	-	-	-	-	-	-	-	-	-
Ring 4	-	-	-	-	-	-	-	-	-	-	-	-	-	-	-

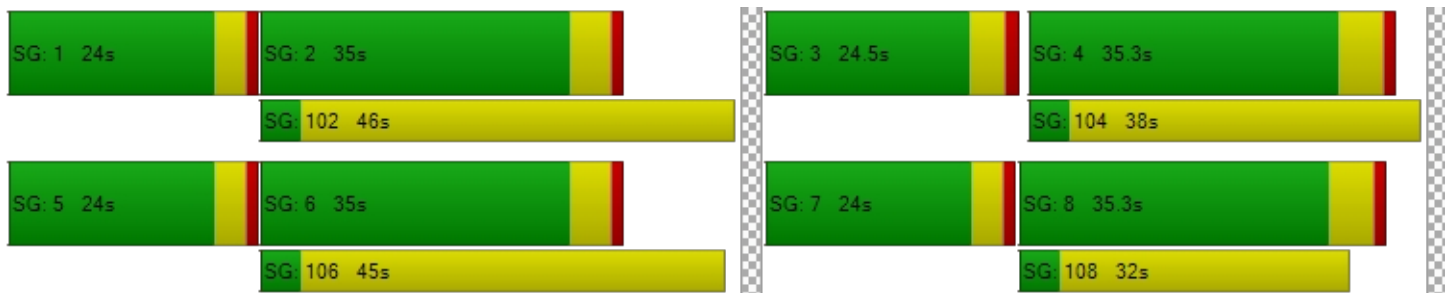

**Intersection Level Of Service Report**  
**Intersection 9: Fallon Road & Dublin Boulevard**

Control Type:	Signalized	Delay (sec / veh):	48.1
Analysis Method:	HCM 7th Edition	Level Of Service:	D
Analysis Period:	15 minutes	Volume to Capacity (v/c):	0.741

**Intersection Setup**

Name	Fallon Road			Fallon Road			Dublin Boulevard			Dublin Boulevard		
Approach	Northbound			Southbound			Eastbound			Westbound		
Lane Configuration	[Diagram]			[Diagram]			[Diagram]			[Diagram]		
Turning Movement	Left	Thru	Right	Left	Thru	Right	Left	Thru	Right	Left	Thru	Right
Lane Width [ft]	12.00	12.00	12.00	12.00	12.00	12.00	12.00	12.00	12.00	12.00	12.00	12.00
No. of Lanes in Entry Pocket	3	0	2	2	0	1	2	0	2	2	0	1
Entry Pocket Length [ft]	430.00	100.00	100.00	140.00	100.00	225.00	400.00	100.00	400.00	100.00	100.00	100.00
No. of Lanes in Exit Pocket	0	0	1	0	0	1	0	0	1	0	0	1
Exit Pocket Length [ft]	0.00	0.00	100.00	0.00	0.00	100.00	0.00	0.00	500.00	0.00	0.00	100.00
Speed [mph]	45.00			45.00			45.00			45.00		
Grade [%]	0.00			0.00			0.00			0.00		
Curb Present	Yes			Yes			Yes			Yes		
Crosswalk	No			No			Yes			Yes		



**Volumes**

Name	Fallon Road			Fallon Road			Dublin Boulevard			Dublin Boulevard		
Base Volume Input [veh/h]	396	903	106	220	1216	128	222	1784	372	178	27	43
Base Volume Adjustment Factor	1.0000	1.0000	1.0000	1.0000	1.0000	1.0000	1.0000	1.0000	1.0000	1.0000	1.0000	1.0000
Heavy Vehicles Percentage [%]	3.70	0.30	4.00	1.00	0.70	1.60	0.00	4.00	2.20	1.00	1.00	1.00
Proportion of CAVs [%]	0.00											
Growth Factor	1.0000	1.0000	1.0000	1.0000	1.0000	1.0000	1.0000	1.0000	1.0000	1.0000	1.0000	1.0000
In-Process Volume [veh/h]	0	0	0	0	0	0	0	0	0	0	0	0
Site-Generated Trips [veh/h]	0	0	0	0	0	0	0	0	0	0	0	0
Diverted Trips [veh/h]	0	0	0	0	0	0	0	0	0	0	0	0
Pass-by Trips [veh/h]	0	0	0	0	0	0	0	0	0	0	0	0
Existing Site Adjustment Volume [veh/h]	0	0	0	0	0	0	0	0	0	0	0	0
Other Volume [veh/h]	0	0	0	0	0	0	0	0	0	0	0	0
Right Turn on Red Volume [veh/h]	0	0	0	0	0	0	0	0	0	0	0	0
Total Hourly Volume [veh/h]	396	903	106	220	1216	128	222	1784	372	178	27	43
Peak Hour Factor	0.9400	0.9400	0.9400	0.9400	0.9400	0.9400	0.9400	0.9400	0.9400	0.9400	0.9400	0.9400
Other Adjustment Factor	1.0000	1.0000	1.0000	1.0000	1.0000	1.0000	1.0000	1.0000	1.0000	1.0000	1.0000	1.0000
Total 15-Minute Volume [veh/h]	105	240	28	59	323	34	59	474	99	47	7	11
Total Analysis Volume [veh/h]	421	961	113	234	1294	136	236	1898	396	189	29	46
Presence of On-Street Parking	No		No	No		No	No		No	No		No
On-Street Parking Maneuver Rate [/h]	0	0	0	0	0	0	0	0	0	0	0	0
Local Bus Stopping Rate [/h]	0	0	0	0	0	0	0	0	0	0	0	0
v_do, Outbound Pedestrian Volume crossing	0			0			0			0		
v_di, Inbound Pedestrian Volume crossing m	0			0			0			0		
v_co, Outbound Pedestrian Volume crossing	0			2			3			0		
v_ci, Inbound Pedestrian Volume crossing mi	0			3			2			0		
v_ab, Corner Pedestrian Volume [ped/h]	0			0			0			0		
Bicycle Volume [bicycles/h]	0			1			0			0		



**Intersection Settings**

Located in CBD	No
Signal Coordination Group	-
Cycle Length [s]	160
Active Pattern	Pattern 1
Coordination Type	Time of Day Pattern Isolated
Actuation Type	Fully actuated
Offset [s]	0.0
Offset Reference	Lead Green - Beginning of First Green
Permissive Mode	SingleBand
Lost time [s]	12.00

**Phasing & Timing (Basic)**

Control Type	Protecte	Permiss	Permiss	Protecte	Permiss	Permiss	Protecte	Permiss	Overlap	Protecte	Permiss	Permiss
Signal Group	3	8	0	7	4	0	5	2	2	1	6	0
Auxiliary Signal Groups									2,3			
Maximum Green [s]	30	30	0	12	30	0	30	30	30	12	12	0
Amber [s]	4.3	4.7	0.0	4.3	4.7	0.0	4.3	4.3	4.3	3.0	4.8	0.0
All red [s]	1.0	1.0	0.0	1.0	1.0	0.0	1.0	1.0	1.0	1.0	1.0	0.0
Walk [s]	0	0	0	0	4	0	0	0	0	0	0	0
Pedestrian Clearance [s]	0	0	0	0	41	0	0	0	0	0	0	0
Delayed Vehicle Green [s]	0.0	0.0	0.0	0.0	0.0	0.0	0.0	0.0	0.0	0.0	0.0	0.0
Rest In Walk		No			No			No			No	
I1, Start-Up Lost Time [s]	2.0	2.0	0.0	2.0	2.0	0.0	2.0	2.0	2.0	2.0	2.0	0.0
I2, Clearance Lost Time [s]	2.0	2.0	0.0	2.0	2.0	0.0	2.0	2.0	2.0	2.0	2.0	0.0
Detector Location [ft]	0.0	0.0	0.0	0.0	0.0	0.0	0.0	0.0	0.0	0.0	0.0	0.0
Detector Length [ft]	0.0	0.0	0.0	0.0	0.0	0.0	20.0	20.0	20.0	0.0	0.0	0.0
I, Upstream Filtering Factor	1.00	1.00	1.00	1.00	1.00	1.00	1.00	1.00	1.00	1.00	1.00	1.00

**Phasing & Timing: Pattern 1**

Split [s]	19	53	0	17	51	0	17	75	75	15	73	0
Lead / Lag	Lead	-	-	Lead	-	-	Lead	-	-	Lead	-	-
Minimum Green [s]	10	12	0	10	12	0	10	12	12	10	10	0
Vehicle Extension [s]	2.0	4.0	0.0	2.0	4.0	0.0	2.0	4.0	4.0	2.0	2.0	0.0
Minimum Recall	No	Yes		No	Yes		No	No	No	No	No	
Maximum Recall	No	No		No	No		No	No	No	No	No	
Pedestrian Recall	No	No		No	No		No	No	No	No	No	

**Exclusive Pedestrian Phase**

Pedestrian Signal Group	0
Pedestrian Walk [s]	0
Pedestrian Clearance [s]	0



**Lane Group Calculations**

Lane Group	L	C	R	L	C	R	L	C	R	L	C	R
C, Cycle Length [s]	160	160	160	160	160	160	160	160	160	160	160	160
L, Total Lost Time per Cycle [s]	4.00	4.00	4.00	4.00	4.00	4.00	4.00	4.00	4.00	4.00	4.00	4.00
l1_p, Permitted Start-Up Lost Time [s]	0.00	0.00	0.00	0.00	0.00	0.00	0.00	0.00	0.00	0.00	0.00	0.00
l2, Clearance Lost Time [s]	2.00	2.00	2.00	2.00	2.00	2.00	2.00	2.00	0.00	2.00	2.00	2.00
g_i, Effective Green Time [s]	16	49	49	14	47	47	13	72	91	10	69	69
g / C, Green / Cycle	0.10	0.31	0.31	0.08	0.29	0.29	0.08	0.45	0.57	0.06	0.43	0.43
(v / s)_i Volume / Saturation Flow Rate	0.08	0.14	0.04	0.07	0.19	0.09	0.07	0.38	0.14	0.04	0.01	0.03
s, saturation flow rate [veh/h]	5117	6884	2768	3486	6863	1566	3514	5012	2809	5230	5135	1602
c, Capacity [veh/h]	500	2104	846	296	2009	459	286	2241	1577	327	2199	686
d1, Uniform Delay [s]	70.97	44.83	40.21	71.82	49.30	43.74	72.37	39.36	17.90	72.94	26.30	26.92
k, delay calibration	0.04	0.50	0.50	0.04	0.50	0.50	0.04	0.15	0.15	0.04	0.04	0.04
l, Upstream Filtering Factor	1.00	1.00	1.00	1.00	1.00	1.00	1.00	1.00	1.00	1.00	1.00	1.00
d2, Incremental Delay [s]	1.52	0.72	0.33	1.82	1.60	1.65	2.33	1.34	0.12	0.60	0.00	0.02
d3, Initial Queue Delay [s]	0.00	0.00	0.00	0.00	0.00	0.00	0.00	0.00	0.00	0.00	0.00	0.00
Rp, platoon ratio	1.00	1.00	1.00	1.00	1.00	1.00	1.00	1.00	1.00	1.00	1.00	1.00
PF, progression factor	1.00	1.00	1.00	1.00	1.00	1.00	1.00	1.00	1.00	1.00	1.00	1.00

**Lane Group Results**

X, volume / capacity	0.84	0.46	0.13	0.79	0.64	0.30	0.83	0.85	0.25	0.58	0.01	0.07
d, Delay for Lane Group [s/veh]	72.49	45.54	40.54	73.64	50.91	45.38	74.70	40.71	18.02	73.55	26.30	26.94
Lane Group LOS	E	D	D	E	D	D	E	D	B	E	C	C
Critical Lane Group	Yes	No	No	No	Yes	No	No	Yes	No	Yes	No	No
50th-Percentile Queue Length [veh/ln]	5.66	7.72	1.65	4.73	11.33	4.35	4.81	21.67	3.70	2.51	0.21	1.04
50th-Percentile Queue Length [ft/ln]	141.51	193.08	41.14	118.26	283.14	108.75	120.16	541.71	92.48	62.71	5.31	25.93
95th-Percentile Queue Length [veh/ln]	9.56	12.28	2.96	8.30	16.84	7.77	8.40	29.30	6.66	4.52	0.38	1.87
95th-Percentile Queue Length [ft/ln]	239.05	307.02	74.06	207.43	421.12	194.26	210.04	732.56	166.46	112.89	9.56	46.68



**Movement, Approach, & Intersection Results**

d_M, Delay for Movement [s/veh]	72.49	45.54	40.54	73.64	50.91	45.38	74.70	40.71	18.02	73.55	26.30	26.94
Movement LOS	E	D	D	E	D	D	E	D	B	E	C	C
d_A, Approach Delay [s/veh]	52.75			53.65			40.33			60.23		
Approach LOS	D			D			D			E		
d_I, Intersection Delay [s/veh]	48.05											
Intersection LOS	D											
Intersection V/C	0.741											

**Emissions**

Vehicle Miles Traveled [mph]	56.54	129.07	15.18	61.96	342.61	36.01	283.94	2283.59	476.45	42.41	6.51	10.32
Stops [stops/h]	382.10	695.14	74.06	212.87	1019.37	97.88	216.29	1462.69	166.47	169.34	14.34	23.34
Fuel consumption [US gal/h]	12.90	21.97	2.37	8.28	37.82	3.71	16.01	112.18	19.85	6.39	0.56	0.90
CO [g/h]	901.62	1535.91	165.88	578.53	2643.76	259.13	1119.05	7841.62	1387.74	446.49	38.91	62.64
NOx [g/h]	175.42	298.83	32.27	112.56	514.38	50.42	217.73	1525.69	270.00	86.87	7.57	12.19
VOC [g/h]	208.96	355.96	38.44	134.08	612.72	60.06	259.35	1817.37	321.62	103.48	9.02	14.52

**Other Modes**

g_Walk,mi, Effective Walk Time [s]	0.0			0.0			8.0			47.3		
M_corner, Corner Circulation Area [ft <sup>2</sup> /ped]	0.00			0.00			0.00			0.00		
M_CW, Crosswalk Circulation Area [ft <sup>2</sup> /ped]	0.00			0.00			657.20			0.00		
d_p, Pedestrian Delay [s]	0.00			0.00			72.20			39.69		
I_p,int, Pedestrian LOS Score for Intersectio	0.000			0.000			3.451			3.338		
Crosswalk LOS	F			F			C			C		
s_b, Saturation Flow Rate of the bicycle lane	2000			2000			2000			2000		
c_b, Capacity of the bicycle lane [bicycles/h]	591			566			871			840		
d_b, Bicycle Delay [s]	39.69			41.13			25.48			26.91		
I_b,int, Bicycle LOS Score for Intersection	2.176			2.246			2.951			1.705		
Bicycle LOS	B			B			C			A		

**Sequence**

Ring 1	1	2	3	4	-	-	-	-	-	-	-	-	-	-	-
Ring 2	5	6	7	8	-	-	-	-	-	-	-	-	-	-	-
Ring 3	-	-	-	-	-	-	-	-	-	-	-	-	-	-	-
Ring 4	-	-	-	-	-	-	-	-	-	-	-	-	-	-	-



**Intersection Level Of Service Report**  
**Intersection 10: Fallon Road & Fallon Gateway**

Control Type:	Signalized	Delay (sec / veh):	10.7
Analysis Method:	HCM 7th Edition	Level Of Service:	B
Analysis Period:	15 minutes	Volume to Capacity (v/c):	0.477

**Intersection Setup**

Name	Fallon Road		Fallon Road		Fallon Gateway	
Approach	Northbound		Southbound		Eastbound	
Lane Configuration	↵↵		↵↵		↵↵↵↵	
Turning Movement	Left	Thru	Thru	Right	Left	Right
Lane Width [ft]	12.00	12.00	12.00	12.00	12.00	12.00
No. of Lanes in Entry Pocket	2	0	0	1	1	1
Entry Pocket Length [ft]	275.00	100.00	100.00	100.00	210.00	210.00
No. of Lanes in Exit Pocket	0	2	0	0	0	0
Exit Pocket Length [ft]	0.00	100.00	0.00	0.00	0.00	0.00
Speed [mph]	45.00		40.00		25.00	
Grade [%]	0.00		0.00		0.00	
Curb Present	Yes		Yes		Yes	
Crosswalk	No		No		Yes	





**Volumes**

Name	Fallon Road		Fallon Road		Fallon Gateway	
Base Volume Input [veh/h]	309	1338	1452	115	62	304
Base Volume Adjustment Factor	1.0000	1.0000	1.0000	1.0000	1.0000	1.0000
Heavy Vehicles Percentage [%]	1.00	0.60	1.30	1.00	0.00	1.30
Proportion of CAVs [%]	0.00					
Growth Factor	1.0000	1.0000	1.0000	1.0000	1.0000	1.0000
In-Process Volume [veh/h]	0	0	0	0	0	0
Site-Generated Trips [veh/h]	0	0	0	0	0	0
Diverted Trips [veh/h]	0	0	0	0	0	0
Pass-by Trips [veh/h]	0	0	0	0	0	0
Existing Site Adjustment Volume [veh/h]	0	0	0	0	0	0
Other Volume [veh/h]	0	0	0	0	0	0
Right Turn on Red Volume [veh/h]	0	0	0	0	0	0
Total Hourly Volume [veh/h]	309	1338	1452	115	62	304
Peak Hour Factor	0.9400	0.9400	0.9400	0.9400	0.9400	0.9400
Other Adjustment Factor	1.0000	1.0000	1.0000	1.0000	1.0000	1.0000
Total 15-Minute Volume [veh/h]	82	356	386	31	16	81
Total Analysis Volume [veh/h]	329	1423	1545	122	66	323
Presence of On-Street Parking	No	No	No	No	No	No
On-Street Parking Maneuver Rate [/h]	0	0	0	0	0	0
Local Bus Stopping Rate [/h]	0	0	0	0	0	0
v_do, Outbound Pedestrian Volume crossing	0		0		0	
v_di, Inbound Pedestrian Volume crossing m	0		0		0	
v_co, Outbound Pedestrian Volume crossing	0		0		0	
v_ci, Inbound Pedestrian Volume crossing mi	0		0		0	
v_ab, Corner Pedestrian Volume [ped/h]	0		0		0	
Bicycle Volume [bicycles/h]	0		0		0	



**Intersection Settings**

Located in CBD	No
Signal Coordination Group	-
Cycle Length [s]	105
Active Pattern	Pattern 1
Coordination Type	Time of Day Pattern Isolated
Actuation Type	Fully actuated
Offset [s]	0.0
Offset Reference	Lead Green - Beginning of First Green
Permissive Mode	SingleBand
Lost time [s]	9.00

**Phasing & Timing (Basic)**

Control Type	Protected	Permissive	Permissive	Permissive	Permissive	Overlap
Signal Group	3	8	4	0	2	2
Auxiliary Signal Groups						2,3
Maximum Green [s]	20	40	40	0	30	30
Amber [s]	3.5	4.7	4.7	0.0	3.5	3.5
All red [s]	1.0	1.0	1.0	0.0	1.0	1.0
Walk [s]	0	0	4	0	0	0
Pedestrian Clearance [s]	0	0	28	0	0	0
Delayed Vehicle Green [s]	0.0	0.0	0.0	0.0	0.0	0.0
Rest In Walk		No	No		No	
I1, Start-Up Lost Time [s]	2.0	2.0	2.0	0.0	2.0	2.0
I2, Clearance Lost Time [s]	2.5	3.7	3.7	0.0	2.5	2.5
Detector Location [ft]	0.0	0.0	0.0	0.0	0.0	0.0
Detector Length [ft]	0.0	0.0	0.0	0.0	20.0	20.0
I, Upstream Filtering Factor	1.00	1.00	1.00	1.00	1.00	1.00

**Phasing & Timing: Pattern 1**

Split [s]	25	70	45	0	35	35
Lead / Lag	Lead	-	-	-	Lead	-
Minimum Green [s]	10	10	10	0	10	10
Vehicle Extension [s]	2.0	5.0	5.0	0.0	2.0	2.0
Minimum Recall	No	Yes	Yes		No	No
Maximum Recall	No	No	No		No	No
Pedestrian Recall	No	No	No		No	No

**Exclusive Pedestrian Phase**

Pedestrian Signal Group	0
Pedestrian Walk [s]	0
Pedestrian Clearance [s]	0



**Lane Group Calculations**

Lane Group	L	C	C	R	L	R
C, Cycle Length [s]	69	69	69	69	69	69
L, Total Lost Time per Cycle [s]	4.50	5.70	5.70	5.70	4.50	4.50
l1_p, Permitted Start-Up Lost Time [s]	0.00	0.00	0.00	0.00	0.00	0.00
l2, Clearance Lost Time [s]	2.50	3.70	3.70	3.70	2.50	0.00
g_i, Effective Green Time [s]	10	48	34	34	10	25
g / C, Green / Cycle	0.15	0.70	0.49	0.49	0.15	0.36
(v / s)_i Volume / Saturation Flow Rate	0.09	0.21	0.23	0.08	0.02	0.11
s, saturation flow rate [veh/h]	3486	6868	6830	1602	3514	2829
c, Capacity [veh/h]	510	4839	3366	790	516	1014
d1, Uniform Delay [s]	27.62	3.78	11.41	9.55	25.46	15.94
k, delay calibration	0.04	0.23	0.23	0.23	0.04	0.04
l, Upstream Filtering Factor	1.00	1.00	1.00	1.00	1.00	1.00
d2, Incremental Delay [s]	0.51	0.07	0.21	0.19	0.04	0.07
d3, Initial Queue Delay [s]	0.00	0.00	0.00	0.00	0.00	0.00
Rp, platoon ratio	1.00	1.00	1.00	1.00	1.00	1.00
PF, progression factor	1.00	1.00	1.00	1.00	1.00	1.00

**Lane Group Results**

X, volume / capacity	0.65	0.29	0.46	0.15	0.13	0.32
d, Delay for Lane Group [s/veh]	28.13	3.85	11.62	9.75	25.50	16.00
Lane Group LOS	C	A	B	A	C	B
Critical Lane Group	Yes	No	Yes	No	No	Yes
50th-Percentile Queue Length [veh/ln]	2.34	0.95	3.20	0.88	0.46	1.75
50th-Percentile Queue Length [ft/ln]	58.50	23.66	80.00	21.90	11.49	43.78
95th-Percentile Queue Length [veh/ln]	4.21	1.70	5.76	1.58	0.83	3.15
95th-Percentile Queue Length [ft/ln]	105.31	42.58	143.99	39.41	20.69	78.80

**Movement, Approach, & Intersection Results**

d_M, Delay for Movement [s/veh]	28.13	3.85	11.62	9.75	25.50	16.00
Movement LOS	C	A	B	A	C	B
d_A, Approach Delay [s/veh]	8.41		11.48		17.62	
Approach LOS	A		B		B	
d_I, Intersection Delay [s/veh]	10.69					
Intersection LOS	B					
Intersection V/C	0.477					

**Emissions**

Vehicle Miles Traveled [mph]	50.06	216.50	207.50	16.39	4.05	19.82
Stops [stops/h]	245.98	198.94	672.67	46.03	48.32	184.05
Fuel consumption [US gal/h]	6.66	11.01	17.69	1.28	0.71	2.65
CO [g/h]	465.38	769.55	1236.77	89.55	49.62	185.18
NOx [g/h]	90.55	149.73	240.63	17.42	9.66	36.03
VOC [g/h]	107.86	178.35	286.63	20.75	11.50	42.92

**Other Modes**

g_Walk,mi, Effective Walk Time [s]	0.0		0.0		8.0	
M_corner, Corner Circulation Area [ft <sup>2</sup> /ped]	0.00		0.00		0.00	
M_CW, Crosswalk Circulation Area [ft <sup>2</sup> /ped]	0.00		0.00		0.00	
d_p, Pedestrian Delay [s]	0.00		0.00		26.72	
I_p,int, Pedestrian LOS Score for Intersectio	0.000		0.000		2.556	
Crosswalk LOS	F		F		B	
s_b, Saturation Flow Rate of the bicycle lane	2000		2000		2000	
c_b, Capacity of the bicycle lane [bicycles/h]	1877		1147		891	
d_b, Bicycle Delay [s]	0.13		6.22		10.54	
I_b,int, Bicycle LOS Score for Intersection	2.282		2.247		1.560	
Bicycle LOS	B		B		A	

**Sequence**

Ring 1	-	2	3	4	-	-	-	-	-	-	-	-	-	-	-	-
Ring 2	-	-	-	8	-	-	-	-	-	-	-	-	-	-	-	-
Ring 3	-	-	-	-	-	-	-	-	-	-	-	-	-	-	-	-
Ring 4	-	-	-	-	-	-	-	-	-	-	-	-	-	-	-	-



**Intersection Level Of Service Report**  
**Intersection 11: Fallon Road & I-580 WB Ramps**

Control Type:	Signalized	Delay (sec / veh):	61.5
Analysis Method:	HCM 7th Edition	Level Of Service:	E
Analysis Period:	15 minutes	Volume to Capacity (v/c):	0.751

**Intersection Setup**

Name	Fallon Road			Fallon Road			I-580 WB On-Ramp			I-580 WB Off-Ramp		
Approach	Northbound			Southbound			Eastbound			Westbound		
Lane Configuration	↑			↑↑↑						↑↑↑		
Turning Movement	Left	Thru	Right	Left	Thru	Right	Left	Thru	Right	Left	Thru	Right
Lane Width [ft]	12.00	12.00	12.00	12.00	12.00	12.00	12.00	12.00	12.00	12.00	12.00	12.00
No. of Lanes in Entry Pocket	0	0	0	0	0	1	0	0	0	1	0	1
Entry Pocket Length [ft]	100.00	100.00	100.00	100.00	100.00	225.00	100.00	100.00	100.00	170.00	100.00	130.00
No. of Lanes in Exit Pocket	0	0	1	0	0	0	0	0	1	0	0	0
Exit Pocket Length [ft]	0.00	0.00	400.00	0.00	0.00	0.00	0.00	0.00	400.00	0.00	0.00	0.00
Speed [mph]	45.00			40.00			30.00			35.00		
Grade [%]	0.00			0.00			0.00			0.00		
Curb Present	No			No						No		
Crosswalk	No			No			No			No		



**Volumes**

Name	Fallon Road			Fallon Road			I-580 WB On-Ramp			I-580 WB Off-Ramp		
Base Volume Input [veh/h]	0	1113	0	0	1359	674	0	0	0	421	1	590
Base Volume Adjustment Factor	1.0000	1.0000	1.0000	1.0000	1.0000	1.0000	1.0000	1.0000	1.0000	1.0000	1.0000	1.0000
Heavy Vehicles Percentage [%]	2.00	0.10	2.00	2.00	0.60	1.00	2.00	2.00	2.00	0.80	0.00	1.50
Proportion of CAVs [%]	0.00											
Growth Factor	1.0000	1.0000	1.0000	1.0000	1.0000	1.0000	1.0000	1.0000	1.0000	1.0000	1.0000	1.0000
In-Process Volume [veh/h]	0	0	0	0	0	0	0	0	0	0	0	0
Site-Generated Trips [veh/h]	0	0	0	0	0	0	0	0	0	0	0	0
Diverted Trips [veh/h]	0	0	0	0	0	0	0	0	0	0	0	0
Pass-by Trips [veh/h]	0	0	0	0	0	0	0	0	0	0	0	0
Existing Site Adjustment Volume [veh/h]	0	0	0	0	0	0	0	0	0	0	0	0
Other Volume [veh/h]	0	0	0	0	0	0	0	0	0	0	0	0
Right Turn on Red Volume [veh/h]	0	0	0	0	0	0	0	0	0	0	0	0
Total Hourly Volume [veh/h]	0	1113	0	0	1359	674	0	0	0	421	1	590
Peak Hour Factor	1.0000	0.9500	1.0000	1.0000	0.9500	0.9500	1.0000	1.0000	1.0000	0.9500	0.9500	0.9500
Other Adjustment Factor	1.0000	1.0000	1.0000	1.0000	1.0000	1.0000	1.0000	1.0000	1.0000	1.0000	1.0000	1.0000
Total 15-Minute Volume [veh/h]	0	293	0	0	358	177	0	0	0	111	0	155
Total Analysis Volume [veh/h]	0	1172	0	0	1431	709	0	0	0	443	1	621
Presence of On-Street Parking	No		No	No		No				No		No
On-Street Parking Maneuver Rate [/h]	0	0	0	0	0	0	0	0	0	0	0	0
Local Bus Stopping Rate [/h]	0	0	0	0	0	0	0	0	0	0	0	0
v_do, Outbound Pedestrian Volume crossing	0			0			0			0		
v_di, Inbound Pedestrian Volume crossing m	0			0			0			0		
v_co, Outbound Pedestrian Volume crossing	0			0			0			0		
v_ci, Inbound Pedestrian Volume crossing mi	0			0			0			0		
v_ab, Corner Pedestrian Volume [ped/h]	0			0			0			0		
Bicycle Volume [bicycles/h]	0			0			0			0		



**Intersection Settings**

Located in CBD	No
Signal Coordination Group	-
Cycle Length [s]	90
Active Pattern	Free Running (No Pattern)
Coordination Type	<i>Free Running</i>
Actuation Type	<i>Fully actuated</i>
Offset [s]	0.0
Offset Reference	Lead Green - Beginning of First Green
Permissive Mode	SingleBand
Lost time [s]	9.00

**Phasing & Timing (Basic)**

Control Type	Permiss	Permiss	Permiss	Permiss	Permiss	Permiss	Permiss	Permiss	Permiss	Permiss	Permiss	Overlap
Signal Group	0	2	0	0	6	0	0	0	0	0	8	1
Auxiliary Signal Groups												1,8
Maximum Green [s]	0	35	0	0	35	0	0	0	0	0	20	15
Amber [s]	0.0	4.8	0.0	0.0	4.8	0.0	0.0	0.0	0.0	0.0	3.7	3.7
All red [s]	0.0	0.5	0.0	0.0	0.5	0.0	0.0	0.0	0.0	0.0	0.5	0.5
Walk [s]	0	0	0	0	0	0	0	0	0	0	0	0
Pedestrian Clearance [s]	0	0	0	0	0	0	0	0	0	0	0	0
Delayed Vehicle Green [s]	0.0	0.0	0.0	0.0	0.0	0.0	0.0	0.0	0.0	0.0	0.0	0.0
Rest In Walk		No			No						No	
I1, Start-Up Lost Time [s]	0.0	2.0	0.0	0.0	2.0	0.0	0.0	0.0	0.0	0.0	2.0	2.0
I2, Clearance Lost Time [s]	0.0	3.3	0.0	0.0	3.3	0.0	0.0	0.0	0.0	0.0	2.2	2.2
Detector Location [ft]	0.0	0.0	0.0	0.0	0.0	0.0	0.0	0.0	0.0	0.0	0.0	0.0
Detector Length [ft]	0.0	20.0	0.0	0.0	20.0	0.0	0.0	0.0	0.0	0.0	20.0	20.0
I, Upstream Filtering Factor	1.00	1.00	1.00	1.00	1.00	1.00	1.00	1.00	1.00	1.00	1.00	1.00

**Phasing & Timing: Free Running (No Pattern)**

Split [s]	0	0	0	0	0	0	0	0	0	0	0	0
Lead / Lag	-	-	-	-	-	-	-	-	-	-	-	-
Minimum Green [s]	0	10	0	0	10	0	0	0	0	0	5	4
Vehicle Extension [s]	0.0	0.0	0.0	0.0	0.0	0.0	0.0	0.0	0.0	0.0	0.0	0.0
Minimum Recall		Yes			Yes						No	No
Maximum Recall		No			No						No	No
Pedestrian Recall		No			No						No	No

**Exclusive Pedestrian Phase**

Pedestrian Signal Group	0
Pedestrian Walk [s]	0
Pedestrian Clearance [s]	0



**Lane Group Calculations**

Lane Group	C	C	R		L	C	R
C, Cycle Length [s]	78	78	78		78	78	78
L, Total Lost Time per Cycle [s]	5.30	5.30	5.30		4.20	4.20	4.20
l1_p, Permitted Start-Up Lost Time [s]	0.00	0.00	0.00		0.00	0.00	0.00
l2, Clearance Lost Time [s]	3.30	3.30	3.30		2.20	2.20	0.00
g_i, Effective Green Time [s]	35	54	54		15	15	33
g / C, Green / Cycle	0.45	0.69	0.69		0.19	0.19	0.43
(v / s)_i Volume / Saturation Flow Rate	0.62	0.40	0.44		0.12	0.12	0.22
s, saturation flow rate [veh/h]	1898	3600	1602		1798	1810	2825
c, Capacity [veh/h]	854	2486	1106		337	339	1210
d1, Uniform Delay [s]	21.42	6.19	6.69		29.30	29.30	16.31
k, delay calibration	0.50	0.04	0.41		0.04	0.04	0.04
l, Upstream Filtering Factor	1.00	1.00	1.00		1.00	1.00	1.00
d2, Incremental Delay [s]	175.22	0.08	2.33		0.81	0.81	0.13
d3, Initial Queue Delay [s]	0.00	0.00	0.00		0.00	0.00	0.00
Rp, platoon ratio	1.00	1.00	1.00		1.00	1.00	1.00
PF, progression factor	1.00	1.00	1.00		1.00	1.00	1.00

**Lane Group Results**

X, volume / capacity	1.37	0.58	0.64		0.66	0.66	0.51
d, Delay for Lane Group [s/veh]	196.63	6.27	9.02		30.11	30.11	16.43
Lane Group LOS	F	A	A		C	C	B
Critical Lane Group	Yes	No	No		No	No	Yes
50th-Percentile Queue Length [veh/ln]	54.47	4.00	4.97		3.72	3.75	3.70
50th-Percentile Queue Length [ft/ln]	1361.69	100.07	124.36		93.11	93.68	92.57
95th-Percentile Queue Length [veh/ln]	81.43	7.20	8.63		6.70	6.75	6.66
95th-Percentile Queue Length [ft/ln]	2035.77	180.12	215.80		167.59	168.63	166.62



**Movement, Approach, & Intersection Results**

d_M, Delay for Movement [s/veh]	0.00	196.63	0.00	0.00	6.27	9.02	0.00	0.00	0.00	30.11	30.11	16.43
Movement LOS		F			A	A				C	C	B
d_A, Approach Delay [s/veh]	196.63		7.18			0.00			22.13			
Approach LOS	F		A			A			C			
d_I, Intersection Delay [s/veh]	61.55											
Intersection LOS	E											
Intersection V/C	0.751											

**Emissions**

Vehicle Miles Traveled [mph]	122.15	217.72	107.87	32.10	32.31	90.09
Stops [stops/h]	2519.98	370.37	230.14	172.31	173.37	342.62
Fuel consumption [US gal/h]	82.41	13.26	7.43	3.88	3.90	8.09
CO [g/h]	5760.37	927.02	519.08	270.91	272.60	565.30
NOx [g/h]	1120.76	180.36	100.99	52.71	53.04	109.99
VOC [g/h]	1335.02	214.84	120.30	62.79	63.18	131.01

**Other Modes**

g_Walk,mi, Effective Walk Time [s]	0.0	0.0	0.0	0.0
M_corner, Corner Circulation Area [ft <sup>2</sup> /ped]	0.00	0.00	0.00	0.00
M_CW, Crosswalk Circulation Area [ft <sup>2</sup> /ped]	0.00	0.00	0.00	0.00
d_p, Pedestrian Delay [s]	0.00	0.00	0.00	0.00
I_p,int, Pedestrian LOS Score for Intersectio	0.000	0.000	0.000	0.000
Crosswalk LOS	F	F	F	F
s_b, Saturation Flow Rate of the bicycle lane	2000	2000	2000	2000
c_b, Capacity of the bicycle lane [bicycles/h]	900	900	0	514
d_b, Bicycle Delay [s]	11.78	11.78	38.91	21.48
I_b,int, Bicycle LOS Score for Intersection	3.493	3.325	4.132	3.317
Bicycle LOS	C	C	D	C

**Sequence**

Ring 1	1	2	-	-	-	-	-	-	-	-	-	-	-	-	-
Ring 2	-	6	-	8	-	-	-	-	-	-	-	-	-	-	-
Ring 3	-	-	-	-	-	-	-	-	-	-	-	-	-	-	-
Ring 4	-	-	-	-	-	-	-	-	-	-	-	-	-	-	-



**Intersection Level Of Service Report**  
**Intersection 12: El Charro Road & I-580 EB Ramps**

Control Type:	Signalized	Delay (sec / veh):	8.5
Analysis Method:	HCM 7th Edition	Level Of Service:	A
Analysis Period:	15 minutes	Volume to Capacity (v/c):	0.790

**Intersection Setup**

Name	El Charro Road			Fallon Road			I-580 EB Off-Ramp			I-580 EB On-Ramp		
Approach	Northbound			Southbound			Eastbound			Westbound		
Lane Configuration	↑↑			↑↑			↵↵↵↵					
Turning Movement	Left	Thru	Right	Left	Thru	Right	Left	Thru	Right	Left	Thru	Right
Lane Width [ft]	12.00	12.00	12.00	12.00	12.00	12.00	12.00	12.00	12.00	12.00	12.00	12.00
No. of Lanes in Entry Pocket	0	0	0	1	0	0	1	0	1	0	0	0
Entry Pocket Length [ft]	100.00	100.00	100.00	135.00	100.00	100.00	350.00	100.00	350.00	100.00	100.00	100.00
No. of Lanes in Exit Pocket	0	0	0	0	0	1	0	0	0	0	0	0
Exit Pocket Length [ft]	0.00	0.00	0.00	0.00	0.00	100.00	0.00	0.00	0.00	0.00	0.00	0.00
Speed [mph]	30.00			40.00			35.00			30.00		
Grade [%]	0.00			0.00			0.00			0.00		
Curb Present	No			No			No					
Crosswalk	No			No			No			Yes		



**Volumes**

Name	El Charro Road			Fallon Road			I-580 EB Off-Ramp			I-580 EB On-Ramp		
Base Volume Input [veh/h]	0	1163	0	0	1265	0	453	0	462	0	0	0
Base Volume Adjustment Factor	1.0000	1.0000	1.0000	1.0000	1.0000	1.0000	1.0000	1.0000	1.0000	1.0000	1.0000	1.0000
Heavy Vehicles Percentage [%]	2.00	0.80	2.00	2.00	0.40	2.00	0.30	2.00	1.80	2.00	2.00	2.00
Proportion of CAVs [%]	0.00											
Growth Factor	1.0000	1.0000	1.0000	1.0000	1.0000	1.0000	1.0000	1.0000	1.0000	1.0000	1.0000	1.0000
In-Process Volume [veh/h]	0	0	0	0	0	0	0	0	0	0	0	0
Site-Generated Trips [veh/h]	0	0	0	0	0	0	0	0	0	0	0	0
Diverted Trips [veh/h]	0	0	0	0	0	0	0	0	0	0	0	0
Pass-by Trips [veh/h]	0	0	0	0	0	0	0	0	0	0	0	0
Existing Site Adjustment Volume [veh/h]	0	0	0	0	0	0	0	0	0	0	0	0
Other Volume [veh/h]	0	0	0	0	0	0	0	0	0	0	0	0
Right Turn on Red Volume [veh/h]	0	0	0	0	0	0	0	0	0	0	0	0
Total Hourly Volume [veh/h]	0	1163	0	0	1265	0	453	0	462	0	0	0
Peak Hour Factor	1.0000	0.9600	1.0000	1.0000	0.9600	1.0000	0.9600	1.0000	0.9600	1.0000	1.0000	1.0000
Other Adjustment Factor	1.0000	1.0000	1.0000	1.0000	1.0000	1.0000	1.0000	1.0000	1.0000	1.0000	1.0000	1.0000
Total 15-Minute Volume [veh/h]	0	303	0	0	329	0	118	0	120	0	0	0
Total Analysis Volume [veh/h]	0	1211	0	0	1318	0	472	0	481	0	0	0
Presence of On-Street Parking	No		No	No		No	No		No			
On-Street Parking Maneuver Rate [/h]	0	0	0	0	0	0	0	0	0	0	0	0
Local Bus Stopping Rate [/h]	0	0	0	0	0	0	0	0	0	0	0	0
v_do, Outbound Pedestrian Volume crossing	0			0			0			0		
v_di, Inbound Pedestrian Volume crossing m	0			0			0			0		
v_co, Outbound Pedestrian Volume crossing	0			0			0			0		
v_ci, Inbound Pedestrian Volume crossing mi	0			0			0			0		
v_ab, Corner Pedestrian Volume [ped/h]	0			0			0			0		
Bicycle Volume [bicycles/h]	0			0			0			0		



**Intersection Settings**

Located in CBD	No
Signal Coordination Group	-
Cycle Length [s]	90
Active Pattern	Free Running (No Pattern)
Coordination Type	<i>Free Running</i>
Actuation Type	<i>Fully actuated</i>
Offset [s]	0.0
Offset Reference	Lead Green - Beginning of First Green
Permissive Mode	SingleBand
Lost time [s]	9.00

**Phasing & Timing (Basic)**

Control Type	Permiss	Permiss	Permiss	Permiss	Permiss	Permiss	Permiss	Permiss	Permiss	Permiss	Permiss	Permiss
Signal Group	0	2	0	0	6	0	4	0	0	0	0	0
Auxiliary Signal Groups												
Maximum Green [s]	0	40	0	0	40	0	26	0	0	0	0	0
Amber [s]	0.0	4.8	0.0	0.0	4.8	0.0	3.7	0.0	0.0	0.0	0.0	0.0
All red [s]	0.0	1.0	0.0	0.0	1.0	0.0	0.5	0.0	0.0	0.0	0.0	0.0
Walk [s]	0	0	0	0	0	0	0	0	0	0	0	0
Pedestrian Clearance [s]	0	0	0	0	0	0	0	0	0	0	0	0
Delayed Vehicle Green [s]	0.0	0.0	0.0	0.0	0.0	0.0	0.0	0.0	0.0	0.0	0.0	0.0
Rest In Walk		No			No		No					
I1, Start-Up Lost Time [s]	0.0	2.0	0.0	0.0	2.0	0.0	2.0	0.0	0.0	0.0	0.0	0.0
I2, Clearance Lost Time [s]	0.0	3.3	0.0	0.0	3.3	0.0	2.7	0.0	0.0	0.0	0.0	0.0
Detector Location [ft]	0.0	0.0	0.0	0.0	0.0	0.0	0.0	0.0	0.0	0.0	0.0	0.0
Detector Length [ft]	0.0	0.0	0.0	0.0	0.0	0.0	0.0	0.0	0.0	0.0	0.0	0.0
I, Upstream Filtering Factor	1.00	1.00	1.00	1.00	1.00	1.00	1.00	1.00	1.00	1.00	1.00	1.00

**Phasing & Timing: Free Running (No Pattern)**

Split [s]	0	0	0	0	0	0	0	0	0	0	0	0
Lead / Lag	-	-	-	-	-	-	Lead	-	-	-	-	-
Minimum Green [s]	0	10	0	0	10	0	4	0	0	0	0	0
Vehicle Extension [s]	0.0	0.0	0.0	0.0	0.0	0.0	0.0	0.0	0.0	0.0	0.0	0.0
Minimum Recall		Yes			Yes		No					
Maximum Recall		No			No		No					
Pedestrian Recall		No			No		No					

**Exclusive Pedestrian Phase**

Pedestrian Signal Group	0
Pedestrian Walk [s]	0
Pedestrian Clearance [s]	0



**Lane Group Calculations**

Lane Group	C	C	L	R	
C, Cycle Length [s]	28	28	28	28	
L, Total Lost Time per Cycle [s]	5.30	5.30	4.70	4.70	
l1_p, Permitted Start-Up Lost Time [s]	0.00	0.00	0.00	0.00	
l2, Clearance Lost Time [s]	3.30	3.30	2.70	2.70	
g_i, Effective Green Time [s]	12	12	6	6	
g / C, Green / Cycle	0.43	0.43	0.22	0.22	
(v / s)_i Volume / Saturation Flow Rate	0.34	0.37	0.13	0.17	
s, saturation flow rate [veh/h]	3595	3606	3506	2818	
c, Capacity [veh/h]	1533	1537	765	615	
d1, Uniform Delay [s]	6.98	7.30	9.94	10.37	
k, delay calibration	0.04	0.04	0.04	0.04	
l, Upstream Filtering Factor	1.00	1.00	1.00	1.00	
d2, Incremental Delay [s]	0.35	0.56	0.30	0.83	
d3, Initial Queue Delay [s]	0.00	0.00	0.00	0.00	
Rp, platoon ratio	1.00	1.00	1.00	1.00	
PF, progression factor	1.00	1.00	1.00	1.00	

**Lane Group Results**

X, volume / capacity	0.79	0.86	0.62	0.78	
d, Delay for Lane Group [s/veh]	7.34	7.86	10.24	11.20	
Lane Group LOS	A	A	B	B	
Critical Lane Group	No	Yes	No	Yes	
50th-Percentile Queue Length [veh/ln]	1.52	1.29	0.84	0.93	
50th-Percentile Queue Length [ft/ln]	38.02	32.31	21.07	23.32	
95th-Percentile Queue Length [veh/ln]	2.74	2.33	1.52	1.68	
95th-Percentile Queue Length [ft/ln]	68.44	58.17	37.92	41.98	

**Movement, Approach, & Intersection Results**

d_M, Delay for Movement [s/veh]	0.00	7.34	0.00	0.00	7.86	0.00	10.24	0.00	11.20	0.00	0.00	0.00
Movement LOS		A			A		B		B			
d_A, Approach Delay [s/veh]	7.34		7.86		10.72		0.00					
Approach LOS	A		A		B		A					
d_I, Intersection Delay [s/veh]	8.46											
Intersection LOS	A											
Intersection V/C	0.790											

**Emissions**

Vehicle Miles Traveled [mph]	208.48	129.45	54.84	55.89
Stops [stops/h]	391.35	332.61	216.82	240.07
Fuel consumption [US gal/h]	12.55	10.01	4.70	5.03
CO [g/h]	877.41	699.79	328.85	351.75
NOx [g/h]	170.71	136.15	63.98	68.44
VOC [g/h]	203.35	162.18	76.21	81.52

**Other Modes**

g_Walk,mi, Effective Walk Time [s]	0.0	0.0	0.0	-5.8
M_corner, Corner Circulation Area [ft <sup>2</sup> /ped]	0.00	0.00	0.00	0.00
M_CW, Crosswalk Circulation Area [ft <sup>2</sup> /ped]	0.00	0.00	0.00	0.00
d_p, Pedestrian Delay [s]	0.00	0.00	0.00	20.39
I_p,int, Pedestrian LOS Score for Intersectio	0.000	0.000	0.000	1.693
Crosswalk LOS	F	F	F	A
s_b, Saturation Flow Rate of the bicycle lane	2000	2000	2000	2000
c_b, Capacity of the bicycle lane [bicycles/h]	2859	2859	1858	0
d_b, Bicycle Delay [s]	2.58	2.58	0.07	13.99
I_b,int, Bicycle LOS Score for Intersection	2.559	2.647	1.560	4.132
Bicycle LOS	B	B	A	D

**Sequence**

Ring 1	-	2	-	4	-	-	-	-	-	-	-	-	-	-	-
Ring 2	-	6	-	-	-	-	-	-	-	-	-	-	-	-	-
Ring 3	-	-	-	-	-	-	-	-	-	-	-	-	-	-	-
Ring 4	-	-	-	-	-	-	-	-	-	-	-	-	-	-	-



**Intersection Level Of Service Report**  
**Intersection 13: El Charro Road & Jack London Boulevard**

Control Type:	Signalized	Delay (sec / veh):	31.1
Analysis Method:	HCM 7th Edition	Level Of Service:	C
Analysis Period:	15 minutes	Volume to Capacity (v/c):	0.784

**Intersection Setup**

Name	El Charro Road			El Charro Road			Stoneridge Drive			Jack London Boulevard		
Approach	Northbound			Southbound			Eastbound			Westbound		
Lane Configuration	T T T			R T T			R T T			T T T		
Turning Movement	Left	Thru	Right	Left	Thru	Right	Left	Thru	Right	Left	Thru	Right
Lane Width [ft]	12.00	12.00	12.00	12.00	12.00	12.00	12.00	12.00	12.00	12.00	12.00	12.00
No. of Lanes in Entry Pocket	1	0	2	2	0	1	3	0	1	1	0	2
Entry Pocket Length [ft]	125.00	100.00	175.00	650.00	100.00	450.00	450.00	100.00	325.00	400.00	100.00	775.00
No. of Lanes in Exit Pocket	0	0	0	0	0	2	1	0	0	0	0	0
Exit Pocket Length [ft]	0.00	0.00	0.00	0.00	0.00	100.00	450.00	0.00	0.00	0.00	0.00	0.00
Speed [mph]	30.00			30.00			30.00			30.00		
Grade [%]	0.00			0.00			0.00			0.00		
Curb Present	Yes			Yes			Yes			Yes		
Crosswalk	Yes			No			Yes			Yes		



**Volumes**

Name	El Charro Road			El Charro Road			Stoneridge Drive			Jack London Boulevard		
Base Volume Input [veh/h]	122	377	283	985	280	472	776	523	188	95	168	650
Base Volume Adjustment Factor	1.0000	1.0000	1.0000	1.0000	1.0000	1.0000	1.0000	1.0000	1.0000	1.0000	1.0000	1.0000
Heavy Vehicles Percentage [%]	0.00	20.00	0.00	0.30	44.40	0.80	0.50	0.50	0.00	0.00	1.80	0.60
Proportion of CAVs [%]	0.00											
Growth Factor	1.0000	1.0000	1.0000	1.0000	1.0000	1.0000	1.0000	1.0000	1.0000	1.0000	1.0000	1.0000
In-Process Volume [veh/h]	0	0	0	0	0	0	0	0	0	0	0	0
Site-Generated Trips [veh/h]	0	0	0	0	0	0	0	0	0	0	0	0
Diverted Trips [veh/h]	0	0	0	0	0	0	0	0	0	0	0	0
Pass-by Trips [veh/h]	0	0	0	0	0	0	0	0	0	0	0	0
Existing Site Adjustment Volume [veh/h]	0	0	0	0	0	0	0	0	0	0	0	0
Other Volume [veh/h]	0	0	0	0	0	0	0	0	0	0	0	0
Right Turn on Red Volume [veh/h]	0	0	0	0	0	0	0	0	0	0	0	0
Total Hourly Volume [veh/h]	122	377	283	985	280	472	776	523	188	95	168	650
Peak Hour Factor	0.9200	0.9200	0.9200	0.9200	0.9200	0.9200	0.9200	0.9200	0.9200	0.9200	0.9200	0.9200
Other Adjustment Factor	1.0000	1.0000	1.0000	1.0000	1.0000	1.0000	1.0000	1.0000	1.0000	1.0000	1.0000	1.0000
Total 15-Minute Volume [veh/h]	33	102	77	268	76	128	211	142	51	26	46	177
Total Analysis Volume [veh/h]	133	410	308	1071	304	513	843	568	204	103	183	707
Presence of On-Street Parking	No		No	No		No	No		No	No		No
On-Street Parking Maneuver Rate [/h]	0	0	0	0	0	0	0	0	0	0	0	0
Local Bus Stopping Rate [/h]	0	0	0	0	0	0	0	0	0	0	0	0
v_do, Outbound Pedestrian Volume crossing	0			0			0			0		
v_di, Inbound Pedestrian Volume crossing m	0			0			0			0		
v_co, Outbound Pedestrian Volume crossing	0			0			0			0		
v_ci, Inbound Pedestrian Volume crossing mi	0			0			0			0		
v_ab, Corner Pedestrian Volume [ped/h]	0			0			0			0		
Bicycle Volume [bicycles/h]	0			0			0			0		





**Intersection Settings**

Located in CBD	No
Signal Coordination Group	-
Cycle Length [s]	90
Active Pattern	Free Running (No Pattern)
Coordination Type	<i>Free Running</i>
Actuation Type	<i>Fully actuated</i>
Offset [s]	0.0
Offset Reference	Lead Green - Beginning of First Green
Permissive Mode	SingleBand
Lost time [s]	12.00

**Phasing & Timing (Basic)**

Control Type	ProtPer	Permiss	Permiss	Protecte	Permiss	Permiss	ProtPer	Permiss	Permiss	ProtPer	Permiss	Overlap
Signal Group	7	4	0	3	8	0	1	6	0	5	2	2
Auxiliary Signal Groups												2,3
Maximum Green [s]	5	25	0	35	20	0	4	25	0	7	20	20
Amber [s]	3.0	5.0	0.0	3.0	4.3	0.0	3.0	4.3	0.0	3.0	4.3	4.3
All red [s]	1.0	1.0	0.0	1.0	1.0	0.0	1.0	1.0	0.0	1.0	1.0	1.0
Walk [s]	0	5	0	0	5	0	0	5	0	0	0	0
Pedestrian Clearance [s]	0	28	0	0	28	0	0	30	0	0	0	0
Delayed Vehicle Green [s]	0.0	0.0	0.0	0.0	0.0	0.0	0.0	0.0	0.0	0.0	0.0	0.0
Rest In Walk		No			No			No			No	
I1, Start-Up Lost Time [s]	2.0	2.0	0.0	2.0	2.0	0.0	2.0	2.0	0.0	2.0	2.0	2.0
I2, Clearance Lost Time [s]	2.0	2.0	0.0	2.0	2.0	0.0	2.0	2.0	0.0	2.0	2.0	2.0
Detector Location [ft]	0.0	0.0	0.0	0.0	0.0	0.0	0.0	0.0	0.0	0.0	0.0	0.0
Detector Length [ft]	0.0	0.0	0.0	0.0	0.0	0.0	0.0	0.0	0.0	0.0	0.0	0.0
I, Upstream Filtering Factor	1.00	1.00	1.00	1.00	1.00	1.00	1.00	1.00	1.00	1.00	1.00	1.00

**Phasing & Timing: Free Running (No Pattern)**

Split [s]	0	0	0	0	0	0	0	0	0	0	0	0
Lead / Lag	Lead	-	-	Lead	-	-	Lead	-	-	Lead	-	-
Minimum Green [s]	4	5	0	7	5	0	5	4	0	4	7	7
Vehicle Extension [s]	2.0	2.5	0.0	2.5	2.5	0.0	2.0	3.0	0.0	2.0	3.0	3.0
Minimum Recall	Yes	No		No	No		Yes	Yes		Yes	Yes	Yes
Maximum Recall	No	No		No	No		No	No		No	No	No
Pedestrian Recall	No	No		No	No		No	No		No	No	No

**Exclusive Pedestrian Phase**

Pedestrian Signal Group	0
Pedestrian Walk [s]	0
Pedestrian Clearance [s]	0



**Lane Group Calculations**

Lane Group	L	C	C	L	C	R	L	C	R	L	C	R
C, Cycle Length [s]	100	100	100	100	100	100	100	100	100	100	100	100
L, Total Lost Time per Cycle [s]	4.00	4.00	4.00	4.00	4.00	4.00	4.00	4.00	4.00	4.00	4.00	4.00
l1_p, Permitted Start-Up Lost Time [s]	0.00	0.00	0.00	0.00	0.00	0.00	0.00	0.00	0.00	0.00	0.00	0.00
l2, Clearance Lost Time [s]	0.00	2.00	2.00	2.00	2.00	2.00	0.00	2.00	2.00	0.00	2.00	0.00
g_i, Effective Green Time [s]	56	26	26	26	47	47	36	26	26	36	28	58
g / C, Green / Cycle	0.56	0.26	0.26	0.26	0.47	0.47	0.36	0.26	0.26	0.36	0.28	0.58
(v / s)_i Volume / Saturation Flow Rate	0.33	0.13	0.23	0.20	0.25	0.32	0.35	0.16	0.13	0.11	0.05	0.25
s, saturation flow rate [veh/h]	402	3046	1360	5259	1234	1605	2410	3603	1615	944	3566	2845
c, Capacity [veh/h]	339	796	355	1360	580	754	973	947	425	348	998	1646
d1, Uniform Delay [s]	15.12	31.52	35.27	34.51	18.63	20.64	31.54	32.25	31.10	23.78	27.33	11.82
k, delay calibration	0.50	0.08	0.36	0.08	0.50	0.50	0.50	0.11	0.11	0.11	0.11	0.16
l, Upstream Filtering Factor	1.00	1.00	1.00	1.00	1.00	1.00	1.00	1.00	1.00	1.00	1.00	1.00
d2, Incremental Delay [s]	3.38	0.38	18.36	0.78	3.37	4.90	10.26	0.61	0.84	0.47	0.09	0.26
d3, Initial Queue Delay [s]	0.00	0.00	0.00	0.00	0.00	0.00	0.00	0.00	0.00	0.00	0.00	0.00
Rp, platoon ratio	1.00	1.00	1.00	1.00	1.00	1.00	1.00	1.00	1.00	1.00	1.00	1.00
PF, progression factor	1.00	1.00	1.00	1.00	1.00	1.00	1.00	1.00	1.00	1.00	1.00	1.00

**Lane Group Results**

X, volume / capacity	0.39	0.51	0.87	0.79	0.52	0.68	0.87	0.60	0.48	0.30	0.18	0.43
d, Delay for Lane Group [s/veh]	18.50	31.91	53.63	35.29	22.00	25.54	41.80	32.86	31.94	24.25	27.42	12.08
Lane Group LOS	B	C	D	D	C	C	D	C	C	C	C	B
Critical Lane Group	No	No	Yes	Yes	No	No	Yes	No	No	No	No	Yes
50th-Percentile Queue Length [veh/ln]	1.74	4.21	8.82	8.02	5.31	9.94	6.02	5.99	4.19	1.71	1.66	4.20
50th-Percentile Queue Length [ft/ln]	43.42	105.28	220.51	200.57	132.83	248.62	150.40	149.79	104.83	42.67	41.47	104.98
95th-Percentile Queue Length [veh/ln]	3.13	7.58	13.69	12.67	9.09	15.12	10.04	10.01	7.55	3.07	2.99	7.56
95th-Percentile Queue Length [ft/ln]	78.16	189.42	342.28	316.70	227.34	377.92	250.96	250.15	188.70	76.80	74.64	188.96



**Movement, Approach, & Intersection Results**

d_M, Delay for Movement [s/veh]	18.50	31.91	53.63	35.29	22.00	25.54	41.80	32.86	31.94	24.25	27.42	12.08
Movement LOS	B	C	D	D	C	C	D	C	C	C	C	B
d_A, Approach Delay [s/veh]	37.67			30.50			37.41			16.17		
Approach LOS	D			C			D			B		
d_I, Intersection Delay [s/veh]	31.07											
Intersection LOS	C											
Intersection V/C	0.784											

**Emissions**

Vehicle Miles Traveled [mph]	8.44	26.02	19.55	184.37	52.33	88.31	107.62	72.51	26.04	17.89	31.79	122.83
Stops [stops/h]	62.65	303.82	318.17	868.18	191.66	358.73	651.02	432.26	151.26	61.56	119.67	302.94
Fuel consumption [US gal/h]	1.19	5.41	5.92	20.08	4.57	8.28	15.20	9.17	3.23	1.59	2.99	8.47
CO [g/h]	83.48	378.29	414.06	1403.39	319.74	579.03	1062.26	641.11	226.04	110.79	209.08	591.91
NOx [g/h]	16.24	73.60	80.56	273.05	62.21	112.66	206.68	124.74	43.98	21.56	40.68	115.16
VOC [g/h]	19.35	87.67	95.96	325.25	74.10	134.19	246.19	148.58	52.39	25.68	48.46	137.18

**Other Modes**

g_Walk,mi, Effective Walk Time [s]	9.0		0.0		9.0		9.0
M_corner, Corner Circulation Area [ft <sup>2</sup> /ped]	0.00		0.00		0.00		0.00
M_CW, Crosswalk Circulation Area [ft <sup>2</sup> /ped]	0.00		0.00		0.00		0.00
d_p, Pedestrian Delay [s]	41.31		0.00		41.31		41.31
I_p,int, Pedestrian LOS Score for Intersectio	2.633		0.000		3.213		3.090
Crosswalk LOS	B		F		C		C
s_b, Saturation Flow Rate of the bicycle lane	2000		2000		2000		2000
c_b, Capacity of the bicycle lane [bicycles/h]	501		401		501		401
d_b, Bicycle Delay [s]	28.03		31.90		28.03		31.90
I_b,int, Bicycle LOS Score for Intersection	2.028		4.675		2.892		2.379
Bicycle LOS	B		E		C		B

**Sequence**

Ring 1	1	2	3	4	-	-	-	-	-	-	-	-	-	-	-
Ring 2	5	6	7	8	-	-	-	-	-	-	-	-	-	-	-
Ring 3	-	-	-	-	-	-	-	-	-	-	-	-	-	-	-
Ring 4	-	-	-	-	-	-	-	-	-	-	-	-	-	-	-



**Intersection Level Of Service Report**  
**Intersection 14: Central Parkway & Sunset View Drive**

Control Type:	Signalized	Delay (sec / veh):	11.4
Analysis Method:	HCM 7th Edition	Level Of Service:	B
Analysis Period:	15 minutes	Volume to Capacity (v/c):	0.262

**Intersection Setup**

Name	Driveway			Sunset View Drive			Central Parkway			Central Parkway		
Approach	Northbound			Southbound			Eastbound			Westbound		
Lane Configuration	↵↑			↵↑			↵↑↵			↵↑		
Turning Movement	Left	Thru	Right	Left	Thru	Right	Left	Thru	Right	Left	Thru	Right
Lane Width [ft]	12.00	12.00	12.00	12.00	12.00	12.00	12.00	12.00	12.00	12.00	12.00	12.00
No. of Lanes in Entry Pocket	1	0	0	0	0	1	1	0	1	1	0	0
Entry Pocket Length [ft]	250.00	100.00	100.00	100.00	100.00	85.00	225.00	100.00	800.00	150.00	100.00	100.00
No. of Lanes in Exit Pocket	0	0	0	0	0	0	0	0	0	0	0	0
Exit Pocket Length [ft]	0.00	0.00	0.00	0.00	0.00	0.00	0.00	0.00	0.00	0.00	0.00	0.00
Speed [mph]	30.00			30.00			30.00			30.00		
Grade [%]	0.00			0.00			0.00			0.00		
Curb Present	No			No			No			No		
Crosswalk	Yes			Yes			Yes			Yes		



**Volumes**

Name	Driveway			Sunset View Drive			Central Parkway			Central Parkway		
Base Volume Input [veh/h]	11	1	11	3	3	74	81	141	30	7	94	1
Base Volume Adjustment Factor	1.0000	1.0000	1.0000	1.0000	1.0000	1.0000	1.0000	1.0000	1.0000	1.0000	1.0000	1.0000
Heavy Vehicles Percentage [%]	0.00	0.00	0.00	0.00	0.00	0.00	0.00	0.00	0.00	0.00	0.00	0.00
Proportion of CAVs [%]	0.00											
Growth Factor	1.0000	1.0000	1.0000	1.0000	1.0000	1.0000	1.0000	1.0000	1.0000	1.0000	1.0000	1.0000
In-Process Volume [veh/h]	0	0	0	0	0	0	0	0	0	0	0	0
Site-Generated Trips [veh/h]	0	0	0	0	0	0	0	0	0	0	0	0
Diverted Trips [veh/h]	0	0	0	0	0	0	0	0	0	0	0	0
Pass-by Trips [veh/h]	0	0	0	0	0	0	0	0	0	0	0	0
Existing Site Adjustment Volume [veh/h]	0	0	0	0	0	0	0	0	0	0	0	0
Other Volume [veh/h]	0	0	0	0	0	0	0	0	0	0	0	0
Right Turn on Red Volume [veh/h]	0	0	0	0	0	0	0	0	0	0	0	0
Total Hourly Volume [veh/h]	11	1	11	3	3	74	81	141	30	7	94	1
Peak Hour Factor	0.9200	0.9200	0.9200	0.9200	0.9200	0.9200	0.9200	0.9200	0.9200	0.9200	0.9200	0.9200
Other Adjustment Factor	1.0000	1.0000	1.0000	1.0000	1.0000	1.0000	1.0000	1.0000	1.0000	1.0000	1.0000	1.0000
Total 15-Minute Volume [veh/h]	3	0	3	1	1	20	22	38	8	2	26	0
Total Analysis Volume [veh/h]	12	1	12	3	3	80	88	153	33	8	102	1
Presence of On-Street Parking	No		No	No		No	No		No	No		No
On-Street Parking Maneuver Rate [/h]	0	0	0	0	0	0	0	0	0	0	0	0
Local Bus Stopping Rate [/h]	0	0	0	0	0	0	0	0	0	0	0	0
v_do, Outbound Pedestrian Volume crossing	2			1			1			0		
v_di, Inbound Pedestrian Volume crossing m	1			0			2			1		
v_co, Outbound Pedestrian Volume crossing	0			0			0			0		
v_ci, Inbound Pedestrian Volume crossing mi	0			0			0			0		
v_ab, Corner Pedestrian Volume [ped/h]	0			0			0			0		
Bicycle Volume [bicycles/h]	0			0			1			0		



**Intersection Settings**

Located in CBD	No
Signal Coordination Group	-
Cycle Length [s]	90
Active Pattern	Free Running (No Pattern)
Coordination Type	Free Running
Actuation Type	Fully actuated
Offset [s]	0.0
Offset Reference	Lead Green - Beginning of First Green
Permissive Mode	SingleBand
Lost time [s]	12.00

**Phasing & Timing (Basic)**

Control Type	Protecte	Permiss	Permiss	Protecte	Permiss	Permiss	Protecte	Permiss	Permiss	Protecte	Permiss	Permiss
Signal Group	3	8	0	7	4	0	5	2	0	1	6	0
Auxiliary Signal Groups												
Maximum Green [s]	30	30	0	20	20	0	20	25	0	20	25	0
Amber [s]	3.0	3.0	0.0	3.0	3.0	0.0	3.0	3.6	0.0	3.0	3.6	0.0
All red [s]	1.0	1.0	0.0	1.0	1.0	0.0	1.0	1.0	0.0	1.0	1.0	0.0
Walk [s]	0	4	0	0	4	0	0	4	0	0	4	0
Pedestrian Clearance [s]	0	24	0	0	21	0	0	16	0	0	17	0
Delayed Vehicle Green [s]	0.0	0.0	0.0	0.0	0.0	0.0	0.0	0.0	0.0	0.0	0.0	0.0
Rest In Walk		No			No			No			No	
I1, Start-Up Lost Time [s]	2.0	2.0	0.0	2.0	2.0	0.0	2.0	2.0	0.0	2.0	2.0	0.0
I2, Clearance Lost Time [s]	2.0	2.0	0.0	2.0	2.0	0.0	2.0	2.0	0.0	2.0	2.0	0.0
Detector Location [ft]	0.0	0.0	0.0	0.0	0.0	0.0	0.0	0.0	0.0	0.0	0.0	0.0
Detector Length [ft]	20.0	20.0	0.0	20.0	20.0	0.0	20.0	20.0	0.0	20.0	20.0	0.0
I, Upstream Filtering Factor	1.00	1.00	1.00	1.00	1.00	1.00	1.00	1.00	1.00	1.00	1.00	1.00

**Phasing & Timing: Free Running (No Pattern)**

Split [s]	9	14	0	9	14	0	9	14	0	9	14	0
Lead / Lag	Lead	-	-	Lead	-	-	Lead	-	-	Lead	-	-
Minimum Green [s]	5	10	0	5	10	0	5	10	0	5	10	0
Vehicle Extension [s]	2.0	4.0	0.0	2.0	4.0	0.0	2.0	4.0	0.0	2.0	4.0	0.0
Minimum Recall	No	No		No	No		No	Yes		No	Yes	
Maximum Recall	No	No		No	No		No	No		No	No	
Pedestrian Recall	No	No		No	No		No	No		No	No	

**Exclusive Pedestrian Phase**

Pedestrian Signal Group	0
Pedestrian Walk [s]	0
Pedestrian Clearance [s]	0



**Lane Group Calculations**

Lane Group	L	C	L	C	L	C	R	L	C
C, Cycle Length [s]	31	31	31	31	31	31	31	31	31
L, Total Lost Time per Cycle [s]	4.00	4.00	4.00	4.00	4.00	4.00	4.00	4.00	4.00
l1_p, Permitted Start-Up Lost Time [s]	0.00	0.00	0.00	0.00	0.00	0.00	0.00	0.00	0.00
l2, Clearance Lost Time [s]	2.00	2.00	2.00	2.00	2.00	2.00	2.00	2.00	2.00
g_i, Effective Green Time [s]	1	6	0	5	3	9	9	0	7
g / C, Green / Cycle	0.02	0.18	0.00	0.17	0.09	0.29	0.29	0.01	0.21
(v / s)_i Volume / Saturation Flow Rate	0.01	0.01	0.00	0.05	0.05	0.08	0.02	0.00	0.05
s, saturation flow rate [veh/h]	1810	1634	1810	1624	1810	1900	1572	1810	1897
c, Capacity [veh/h]	30	295	8	273	159	553	457	21	407
d1, Uniform Delay [s]	15.19	10.57	15.49	11.38	13.66	8.53	8.01	15.32	10.18
k, delay calibration	0.04	0.15	0.04	0.15	0.04	0.15	0.15	0.04	0.15
l, Upstream Filtering Factor	1.00	1.00	1.00	1.00	1.00	1.00	1.00	1.00	1.00
d2, Incremental Delay [s]	3.06	0.09	9.63	0.88	1.13	0.38	0.09	4.36	0.46
d3, Initial Queue Delay [s]	0.00	0.00	0.00	0.00	0.00	0.00	0.00	0.00	0.00
Rp, platoon ratio	1.00	1.00	1.00	1.00	1.00	1.00	1.00	1.00	1.00
PF, progression factor	1.00	1.00	1.00	1.00	1.00	1.00	1.00	1.00	1.00

**Lane Group Results**

X, volume / capacity	0.39	0.04	0.36	0.30	0.55	0.28	0.07	0.39	0.25
d, Delay for Lane Group [s/veh]	18.24	10.65	25.12	12.26	14.78	8.92	8.11	19.68	10.64
Lane Group LOS	B	B	C	B	B	A	A	B	B
Critical Lane Group	Yes	No	No	Yes	Yes	No	No	No	Yes
50th-Percentile Queue Length [veh/ln]	0.09	0.06	0.04	0.44	0.51	0.60	0.12	0.07	0.48
50th-Percentile Queue Length [ft/ln]	2.34	1.55	0.98	11.07	12.78	14.95	3.03	1.76	11.91
95th-Percentile Queue Length [veh/ln]	0.17	0.11	0.07	0.80	0.92	1.08	0.22	0.13	0.86
95th-Percentile Queue Length [ft/ln]	4.20	2.79	1.77	19.92	23.00	26.91	5.45	3.16	21.43



**Movement, Approach, & Intersection Results**

d_M, Delay for Movement [s/veh]	18.24	10.65	10.65	25.12	12.26	12.26	14.78	8.92	8.11	19.68	10.64	10.64
Movement LOS	B	B	B	C	B	B	B	A	A	B	B	B
d_A, Approach Delay [s/veh]	14.30			12.71			10.70			11.29		
Approach LOS	B			B			B			B		
d_I, Intersection Delay [s/veh]	11.36											
Intersection LOS	B											
Intersection V/C	0.262											

**Emissions**

Vehicle Miles Traveled [mph]	0.33	0.35	0.11	3.09	20.01	34.78	7.50	1.69	21.77
Stops [stops/h]	10.84	7.19	4.55	51.35	59.27	69.35	14.05	8.16	55.23
Fuel consumption [US gal/h]	0.12	0.08	0.05	0.62	1.42	2.09	0.44	0.15	1.42
CO [g/h]	8.24	5.77	3.15	43.19	98.97	146.28	30.82	10.26	99.58
NOx [g/h]	1.60	1.12	0.61	8.40	19.26	28.46	6.00	2.00	19.37
VOC [g/h]	1.91	1.34	0.73	10.01	22.94	33.90	7.14	2.38	23.08

**Other Modes**

g_Walk,mi, Effective Walk Time [s]	8.0	8.0	8.0	8.0
M_corner, Corner Circulation Area [ft <sup>2</sup> /ped]	0.00	0.00	0.00	0.00
M_CW, Crosswalk Circulation Area [ft <sup>2</sup> /ped]	0.00	0.00	0.00	0.00
d_p, Pedestrian Delay [s]	8.55	8.55	8.55	8.55
I_p,int, Pedestrian LOS Score for Intersectio	1.906	1.941	2.189	1.974
Crosswalk LOS	A	A	B	A
s_b, Saturation Flow Rate of the bicycle lane	2000	2000	2000	2000
c_b, Capacity of the bicycle lane [bicycles/h]	1933	1289	1611	1611
d_b, Bicycle Delay [s]	0.02	1.96	0.59	0.59
I_b,int, Bicycle LOS Score for Intersection	1.601	1.702	2.012	1.743
Bicycle LOS	A	A	B	A

**Sequence**

Ring 1	1	2	3	4	-	-	-	-	-	-	-	-	-	-	-
Ring 2	5	6	7	8	-	-	-	-	-	-	-	-	-	-	-
Ring 3	-	-	-	-	-	-	-	-	-	-	-	-	-	-	-
Ring 4	-	-	-	-	-	-	-	-	-	-	-	-	-	-	-

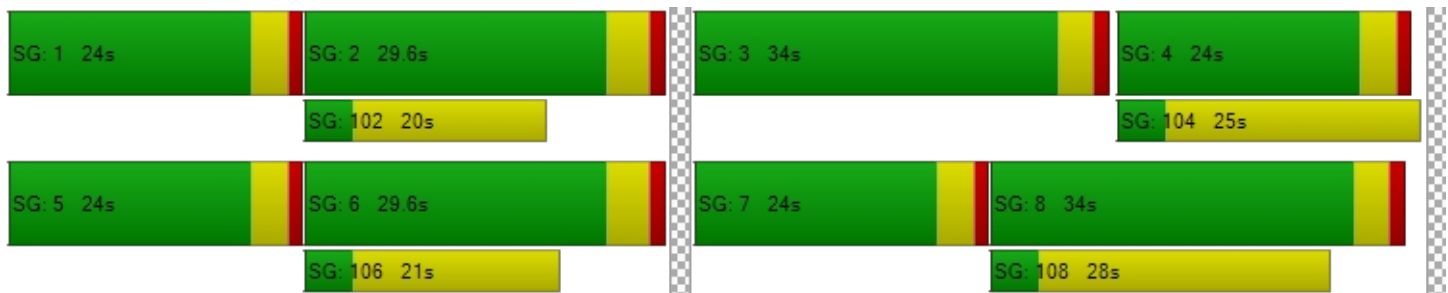



**Intersection Level Of Service Report**

**Intersection 15: Central Parkway & Panorama Drive/Pino Grande Road**

Control Type:	All-way stop	Delay (sec / veh):	8.1
Analysis Method:	HCM 7th Edition	Level Of Service:	A
Analysis Period:	15 minutes	Volume to Capacity (v/c):	0.147

**Intersection Setup**

Name	Pino Grande Road			Panorama Drive			Central Parkway			Central Parkway		
Approach	Northbound			Southbound			Eastbound			Westbound		
Lane Configuration	+			+			+			+		
Turning Movement	Left	Thru	Right	Left	Thru	Right	Left	Thru	Right	Left	Thru	Right
Lane Width [ft]	12.00	12.00	12.00	12.00	12.00	12.00	12.00	12.00	12.00	12.00	12.00	12.00
No. of Lanes in Entry Pocket	0	0	0	0	0	1	1	0	0	1	0	0
Entry Pocket Length [ft]	100.00	100.00	100.00	100.00	100.00	100.00	275.00	100.00	100.00	100.00	100.00	100.00
No. of Lanes in Exit Pocket	0	0	0	0	0	0	0	0	0	0	0	0
Exit Pocket Length [ft]	0.00	0.00	0.00	0.00	0.00	0.00	0.00	0.00	0.00	0.00	0.00	0.00
Speed [mph]	30.00			30.00			30.00			30.00		
Grade [%]	0.00			0.00			0.00			0.00		
Crosswalk	Yes			Yes			Yes			Yes		

**Volumes**

Name	Pino Grande Road			Panorama Drive			Central Parkway			Central Parkway		
Base Volume Input [veh/h]	10	0	0	5	0	67	95	52	10	0	31	24
Base Volume Adjustment Factor	1.0000	1.0000	1.0000	1.0000	1.0000	1.0000	1.0000	1.0000	1.0000	1.0000	1.0000	1.0000
Heavy Vehicles Percentage [%]	0.00	0.00	0.00	0.00	0.00	0.00	0.00	0.00	0.00	0.00	0.00	0.00
Growth Factor	1.0000	1.0000	1.0000	1.0000	1.0000	1.0000	1.0000	1.0000	1.0000	1.0000	1.0000	1.0000
In-Process Volume [veh/h]	0	0	0	0	0	0	0	0	0	0	0	0
Site-Generated Trips [veh/h]	0	0	0	0	0	0	0	0	0	0	0	0
Diverted Trips [veh/h]	0	0	0	0	0	0	0	0	0	0	0	0
Pass-by Trips [veh/h]	0	0	0	0	0	0	0	0	0	0	0	0
Existing Site Adjustment Volume [veh/h]	0	0	0	0	0	0	0	0	0	0	0	0
Other Volume [veh/h]	0	0	0	0	0	0	0	0	0	0	0	0
Total Hourly Volume [veh/h]	10	0	0	5	0	67	95	52	10	0	31	24
Peak Hour Factor	0.9400	0.9400	0.9400	0.9400	0.9400	0.9400	0.9400	0.9400	0.9400	0.9400	0.9400	0.9400
Other Adjustment Factor	1.0000	1.0000	1.0000	1.0000	1.0000	1.0000	1.0000	1.0000	1.0000	1.0000	1.0000	1.0000
Total 15-Minute Volume [veh/h]	3	0	0	1	0	18	25	14	3	0	8	6
Total Analysis Volume [veh/h]	11	0	0	5	0	71	101	55	11	0	33	26
Pedestrian Volume [ped/h]	2			3			2			4		



**Intersection Settings**

**Lanes**

Capacity per Entry Lane [veh/h]	674	647	826	686	777	743	793
Degree of Utilization, x	0.02	0.01	0.09	0.15	0.08	0.00	0.07

**Movement, Approach, & Intersection Results**

95th-Percentile Queue Length [veh]	0.05	0.02	0.28	0.51	0.28	0.00	0.24
95th-Percentile Queue Length [ft]	1.24	0.58	7.04	12.87	6.94	0.00	6.01
Approach Delay [s/veh]	8.43	7.53		8.42		7.60	
Approach LOS	A	A		A		A	
Intersection Delay [s/veh]	8.05						
Intersection LOS	A						



**Intersection Level Of Service Report**  
**Intersection 16: Airway Boulevard & N. Canyons Parkway**

Control Type:	Signalized	Delay (sec / veh):	145.0
Analysis Method:	HCM 7th Edition	Level Of Service:	F
Analysis Period:	15 minutes	Volume to Capacity (v/c):	1.185

**Intersection Setup**

Name	Airway Boulevard			Driveway			N. Canyons Parkway			N Canyons Parkway		
Approach	Northbound			Southbound			Eastbound			Westbound		
Lane Configuration												
Turning Movement	Left	Thru	Right	Left	Thru	Right	Left	Thru	Right	Left	Thru	Right
Lane Width [ft]	12.00	12.00	12.00	12.00	12.00	12.00	12.00	12.00	12.00	12.00	12.00	12.00
No. of Lanes in Entry Pocket	1	0	0	0	0	0	0	0	0	1	0	1
Entry Pocket Length [ft]	100.00	100.00	100.00	100.00	100.00	100.00	100.00	100.00	100.00	110.00	100.00	195.00
No. of Lanes in Exit Pocket	0	0	0	0	0	0	0	0	0	0	0	0
Exit Pocket Length [ft]	0.00	0.00	0.00	0.00	0.00	0.00	0.00	0.00	0.00	0.00	0.00	0.00
Speed [mph]	40.00			30.00			40.00			40.00		
Grade [%]	0.00			0.00			0.00			0.00		
Curb Present	Yes			Yes			Yes			Yes		
Crosswalk	Yes			Yes			Yes			No		



**Volumes**

Name	Airway Boulevard			Driveway			N. Canyons Parkway			N Canyons Parkway		
Base Volume Input [veh/h]	147	39	936	2	8	2	0	1480	730	853	86	9
Base Volume Adjustment Factor	1.0000	1.0000	1.0000	1.0000	1.0000	1.0000	1.0000	1.0000	1.0000	1.0000	1.0000	1.0000
Heavy Vehicles Percentage [%]	4.50	2.60	1.20	0.00	0.00	0.00	2.00	0.00	1.70	0.70	0.00	0.00
Proportion of CAVs [%]	0.00											
Growth Factor	1.0000	1.0000	1.0000	1.0000	1.0000	1.0000	1.0000	1.0000	1.0000	1.0000	1.0000	1.0000
In-Process Volume [veh/h]	0	0	0	0	0	0	0	0	0	0	0	0
Site-Generated Trips [veh/h]	0	0	0	0	0	0	0	0	0	0	0	0
Diverted Trips [veh/h]	0	0	0	0	0	0	0	0	0	0	0	0
Pass-by Trips [veh/h]	0	0	0	0	0	0	0	0	0	0	0	0
Existing Site Adjustment Volume [veh/h]	0	0	0	0	0	0	0	0	0	0	0	0
Other Volume [veh/h]	0	0	0	0	0	0	0	0	0	0	0	0
Right Turn on Red Volume [veh/h]	0	0	0	0	0	0	0	0	0	0	0	0
Total Hourly Volume [veh/h]	147	39	936	2	8	2	0	1480	730	853	86	9
Peak Hour Factor	0.9300	0.9300	0.9300	0.9300	0.9300	0.9300	1.0000	0.9300	0.9300	0.9300	0.9300	0.9300
Other Adjustment Factor	1.0000	1.0000	1.0000	1.0000	1.0000	1.0000	1.0000	1.0000	1.0000	1.0000	1.0000	1.0000
Total 15-Minute Volume [veh/h]	40	10	252	1	2	1	0	398	196	229	23	2
Total Analysis Volume [veh/h]	158	42	1006	2	9	2	0	1591	785	917	92	10
Presence of On-Street Parking	No		No	No		No	No		No	No		No
On-Street Parking Maneuver Rate [/h]	0	0	0	0	0	0	0	0	0	0	0	0
Local Bus Stopping Rate [/h]	0	0	0	0	0	0	0	0	0	0	0	0
v_do, Outbound Pedestrian Volume crossing	2			0			1			0		
v_di, Inbound Pedestrian Volume crossing m	1			0			2			0		
v_co, Outbound Pedestrian Volume crossing	0			0			0			0		
v_ci, Inbound Pedestrian Volume crossing mi	0			0			0			0		
v_ab, Corner Pedestrian Volume [ped/h]	0			0			0			0		
Bicycle Volume [bicycles/h]	0			0			0			0		



**Intersection Settings**

Located in CBD	No
Signal Coordination Group	-
Cycle Length [s]	105
Active Pattern	Pattern 1
Coordination Type	Time of Day Pattern Coordinated
Actuation Type	Fully actuated
Offset [s]	100.0
Offset Reference	Lead Green - Beginning of First Green
Permissive Mode	SingleBand
Lost time [s]	12.00

**Phasing & Timing (Basic)**

Control Type	Split	Split	Overlap	Split	Split	Split	Permiss	Permiss	Permiss	Protecte	Permiss	Permiss
Signal Group	0	8	8	0	4	0	0	2	0	1	6	0
Auxiliary Signal Groups			1,8									
Maximum Green [s]	0	20	20	0	12	0	0	15	0	50	50	0
Amber [s]	0.0	3.2	3.2	0.0	3.0	0.0	0.0	5.0	0.0	5.0	5.0	0.0
All red [s]	0.0	1.0	1.0	0.0	1.0	0.0	0.0	1.0	0.0	1.0	1.0	0.0
Walk [s]	0	0	0	0	5	0	0	5	0	0	5	0
Pedestrian Clearance [s]	0	0	0	0	28	0	0	29	0	0	12	0
Delayed Vehicle Green [s]	0.0	0.0	0.0	0.0	0.0	0.0	0.0	0.0	0.0	0.0	0.0	0.0
Rest In Walk		No			No			No			No	
I1, Start-Up Lost Time [s]	0.0	2.0	2.0	0.0	2.0	0.0	0.0	2.0	0.0	2.0	2.0	0.0
I2, Clearance Lost Time [s]	0.0	2.0	2.0	0.0	2.0	0.0	0.0	2.0	0.0	2.0	2.0	0.0
Detector Location [ft]	0.0	0.0	0.0	0.0	0.0	0.0	0.0	0.0	0.0	0.0	0.0	0.0
Detector Length [ft]	0.0	0.0	0.0	0.0	20.0	0.0	0.0	0.0	0.0	0.0	0.0	0.0
I, Upstream Filtering Factor	1.00	1.00	1.00	1.00	1.00	1.00	1.00	1.00	1.00	1.00	1.00	1.00

**Phasing & Timing: Pattern 1**

Split [s]	0	9	9	0	37	0	0	40	0	19	59	0
Lead / Lag	-	-	-	-	-	-	-	-	-	Lead	-	-
Minimum Green [s]	0	4	4	0	3	0	0	10	0	3	7	0
Vehicle Extension [s]	0.0	2.0	2.0	0.0	2.0	0.0	0.0	2.0	0.0	2.0	2.0	0.0
Minimum Recall		No	No		No			No		No	Yes	
Maximum Recall		No	No		No			No		Yes	Yes	
Pedestrian Recall		No	No		No			No		No	No	

**Exclusive Pedestrian Phase**

Pedestrian Signal Group	0
Pedestrian Walk [s]	0
Pedestrian Clearance [s]	0



**Lane Group Calculations**

Lane Group	L	C	R	C	C	R	L	C	C
C, Cycle Length [s]	105	105	105	105	105	105	105	105	105
L, Total Lost Time per Cycle [s]	4.00	4.00	4.00	4.00	4.00	4.00	4.00	4.00	4.00
l1_p, Permitted Start-Up Lost Time [s]	0.00	0.00	0.00	0.00	0.00	0.00	0.00	0.00	0.00
l2, Clearance Lost Time [s]	2.00	2.00	0.00	2.00	2.00	2.00	2.00	2.00	2.00
g_i, Effective Green Time [s]	32	32	56	1	36	36	21	61	61
g / C, Green / Cycle	0.30	0.30	0.53	0.01	0.34	0.34	0.20	0.58	0.58
(v / s)_i Volume / Saturation Flow Rate	0.06	0.06	0.36	0.01	0.44	0.49	0.26	0.03	0.03
s, saturation flow rate [veh/h]	1745	1808	2831	1836	3618	1589	3495	1900	1835
c, Capacity [veh/h]	523	542	1458	17	1239	544	686	1096	1059
d1, Uniform Delay [s]	27.31	27.28	19.16	51.92	34.52	34.47	42.20	9.66	9.66
k, delay calibration	0.04	0.04	0.50	0.04	0.17	0.50	0.50	0.50	0.50
l, Upstream Filtering Factor	1.00	1.00	1.00	1.00	1.00	1.00	1.00	1.00	1.00
d2, Incremental Delay [s]	0.06	0.06	2.69	24.09	129.93	209.17	161.16	0.08	0.08
d3, Initial Queue Delay [s]	0.00	0.00	0.00	0.00	0.00	0.00	0.00	0.00	0.00
Rp, platoon ratio	1.00	1.00	1.00	1.00	1.00	1.00	1.00	1.00	1.00
PF, progression factor	1.00	1.00	1.00	1.00	1.00	1.00	1.00	1.00	1.00

**Lane Group Results**

X, volume / capacity	0.19	0.19	0.69	0.78	1.28	1.44	1.34	0.05	0.05
d, Delay for Lane Group [s/veh]	27.37	27.34	21.85	76.01	164.45	243.64	203.35	9.74	9.74
Lane Group LOS	C	C	C	E	F	F	F	A	A
Critical Lane Group	No	No	Yes	Yes	No	Yes	Yes	No	No
50th-Percentile Queue Length [veh/ln]	1.81	1.83	8.98	0.45	37.29	44.72	23.95	0.51	0.49
50th-Percentile Queue Length [ft/ln]	45.13	45.77	224.53	11.32	932.16	1118.07	598.81	12.65	12.24
95th-Percentile Queue Length [veh/ln]	3.25	3.30	13.90	0.82	54.96	68.15	36.60	0.91	0.88
95th-Percentile Queue Length [ft/ln]	81.23	82.38	347.40	20.38	1374.12	1703.63	915.08	22.77	22.04

**Movement, Approach, & Intersection Results**

d_M, Delay for Movement [s/veh]	27.37	27.34	21.85	76.01	76.01	76.01	0.00	164.45	243.64	203.35	9.74	9.74
Movement LOS	C	C	C	E	E	E		F	F	F	A	A
d_A, Approach Delay [s/veh]	22.76			76.01				190.61		183.97		
Approach LOS	C			E				F		F		
d_I, Intersection Delay [s/veh]	144.95											
Intersection LOS	F											
Intersection V/C	1.185											

**Emissions**

Vehicle Miles Traveled [mph]	11.78	11.97	119.45	0.45	103.71	51.17	75.00	4.24	4.10
Stops [stops/h]	61.89	62.77	615.82	15.52	2556.65	1533.27	1642.36	17.35	16.79
Fuel consumption [US gal/h]	1.58	1.61	14.80	0.31	82.06	55.81	56.76	0.43	0.41
CO [g/h]	110.64	112.25	1034.66	21.34	5736.25	3901.04	3967.59	29.73	28.74
NOx [g/h]	21.53	21.84	201.31	4.15	1116.07	759.00	771.95	5.78	5.59
VOC [g/h]	25.64	26.01	239.79	4.94	1329.43	904.10	919.53	6.89	6.66

**Other Modes**

g_Walk,mi, Effective Walk Time [s]	9.0	9.0	9.0	0.0
M_corner, Corner Circulation Area [ft <sup>2</sup> /ped]	0.00	0.00	0.00	0.00
M_CW, Crosswalk Circulation Area [ft <sup>2</sup> /ped]	0.00	0.00	0.00	0.00
d_p, Pedestrian Delay [s]	43.89	43.89	43.89	0.00
I_p,int, Pedestrian LOS Score for Intersectio	3.145	1.756	2.992	0.000
Crosswalk LOS	C	A	C	F
s_b, Saturation Flow Rate of the bicycle lane	2000	2000	2000	2000
c_b, Capacity of the bicycle lane [bicycles/h]	91	629	648	1009
d_b, Bicycle Delay [s]	47.81	24.69	24.01	12.88
I_b,int, Bicycle LOS Score for Intersection	3.550	1.581	3.520	2.400
Bicycle LOS	D	A	D	B

**Sequence**

Ring 1	1	2	4	8	-	-	-	-	-	-	-	-	-	-	-
Ring 2	-	6	-	-	-	-	-	-	-	-	-	-	-	-	-
Ring 3	-	-	-	-	-	-	-	-	-	-	-	-	-	-	-
Ring 4	-	-	-	-	-	-	-	-	-	-	-	-	-	-	-

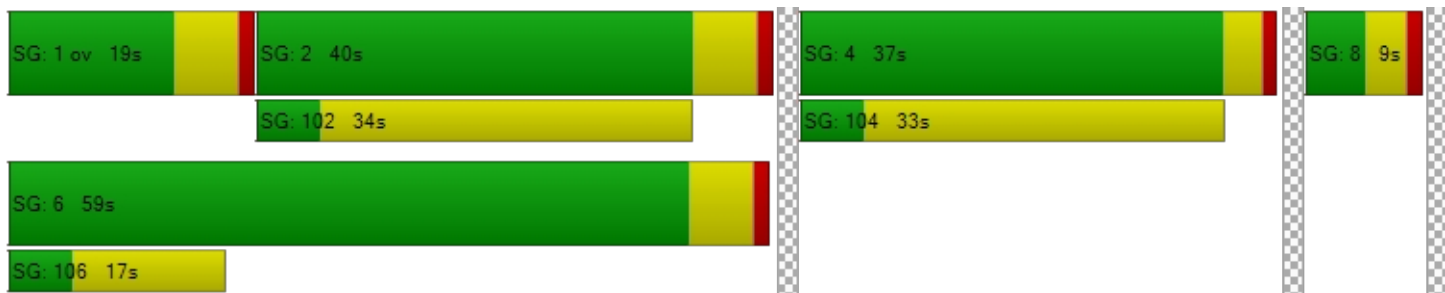

**Intersection Level Of Service Report**  
**Intersection 17: Airway Boulevard & I-580 WB Ramps**

Control Type:	Signalized	Delay (sec / veh):	7.9
Analysis Method:	HCM 7th Edition	Level Of Service:	A
Analysis Period:	15 minutes	Volume to Capacity (v/c):	0.361

**Intersection Setup**

Name	Airway Boulevard			Airway Boulevard			I-580 WB On-Ramp			I-580 WB Off-Ramp		
Approach	Northbound			Southbound			Eastbound			Westbound		
Lane Configuration	r			lr						rllr		
Turning Movement	Left	Thru	Right	Left	Thru	Right	Left	Thru	Right	Left	Thru	Right
Lane Width [ft]	12.00	12.00	12.00	12.00	12.00	12.00	12.00	12.00	12.00	12.00	12.00	12.00
No. of Lanes in Entry Pocket	0	0	0	0	0	1	0	0	0	1	0	1
Entry Pocket Length [ft]	100.00	100.00	100.00	100.00	100.00	250.00	100.00	100.00	100.00	150.00	100.00	490.00
No. of Lanes in Exit Pocket	0	0	0	0	0	0	0	0	0	0	0	0
Exit Pocket Length [ft]	0.00	0.00	0.00	0.00	0.00	0.00	0.00	0.00	0.00	0.00	0.00	0.00
Speed [mph]	40.00			40.00			30.00			45.00		
Grade [%]	0.00			0.00			0.00			0.00		
Curb Present	Yes			Yes						Yes		
Crosswalk	No			No			No			Yes		





**Volumes**

Name	Airway Boulevard			Airway Boulevard			I-580 WB On-Ramp			I-580 WB Off-Ramp		
	Base Volume Input [veh/h]	0	1024	232	0	832	844	0	0	0	51	0
Base Volume Adjustment Factor	1.0000	1.0000	1.0000	1.0000	1.0000	1.0000	1.0000	1.0000	1.0000	1.0000	1.0000	1.0000
Heavy Vehicles Percentage [%]	2.00	1.20	0.00	2.00	0.40	0.70	2.00	2.00	2.00	0.00	0.00	1.10
Proportion of CAVs [%]	0.00											
Growth Factor	1.0000	1.0000	1.0000	1.0000	1.0000	1.0000	1.0000	1.0000	1.0000	1.0000	1.0000	1.0000
In-Process Volume [veh/h]	0	0	0	0	0	0	0	0	0	0	0	0
Site-Generated Trips [veh/h]	0	0	0	0	0	0	0	0	0	0	0	0
Diverted Trips [veh/h]	0	0	0	0	0	0	0	0	0	0	0	0
Pass-by Trips [veh/h]	0	0	0	0	0	0	0	0	0	0	0	0
Existing Site Adjustment Volume [veh/h]	0	0	0	0	0	0	0	0	0	0	0	0
Other Volume [veh/h]	0	0	0	0	0	0	0	0	0	0	0	0
Right Turn on Red Volume [veh/h]	0	0	0	0	0	0	0	0	0	0	0	0
Total Hourly Volume [veh/h]	0	1024	232	0	832	844	0	0	0	51	0	222
Peak Hour Factor	1.0000	0.8900	0.8900	1.0000	0.8900	0.8900	1.0000	1.0000	1.0000	0.8900	0.8900	0.8900
Other Adjustment Factor	1.0000	1.0000	1.0000	1.0000	1.0000	1.0000	1.0000	1.0000	1.0000	1.0000	1.0000	1.0000
Total 15-Minute Volume [veh/h]	0	288	65	0	234	237	0	0	0	14	0	62
Total Analysis Volume [veh/h]	0	1151	261	0	935	948	0	0	0	57	0	249
Presence of On-Street Parking	No		No	No		No				No		No
On-Street Parking Maneuver Rate [/h]	0	0	0	0	0	0	0	0	0	0	0	0
Local Bus Stopping Rate [/h]	0	0	0	0	0	0	0	0	0	0	0	0
v_do, Outbound Pedestrian Volume crossing	0			0			0			0		
v_di, Inbound Pedestrian Volume crossing m	0			0			0			0		
v_co, Outbound Pedestrian Volume crossing	0			0			0			0		
v_ci, Inbound Pedestrian Volume crossing mi	0			0			0			0		
v_ab, Corner Pedestrian Volume [ped/h]	0			0			0			0		
Bicycle Volume [bicycles/h]	1			0			0			0		



**Intersection Settings**

Located in CBD	No
Signal Coordination Group	-
Cycle Length [s]	105
Active Pattern	Pattern 1
Coordination Type	Time of Day Pattern Coordinated
Actuation Type	Fully actuated
Offset [s]	35.0
Offset Reference	Lead Green - Beginning of First Green
Permissive Mode	SingleBand
Lost time [s]	9.00

**Phasing & Timing (Basic)**

Control Type	Permiss	Permiss	Unsigna	Permiss	Permiss	Unsigna	Permiss	Permiss	Permiss	Permiss	Permiss	Overlap
Signal Group	0	2	0	0	6	0	0	0	0	0	8	1
Auxiliary Signal Groups												1,8
Maximum Green [s]	0	30	0	0	25	0	0	0	0	0	20	12
Amber [s]	0.0	4.3	0.0	0.0	4.3	0.0	0.0	0.0	0.0	0.0	3.0	3.0
All red [s]	0.0	1.0	0.0	0.0	1.0	0.0	0.0	0.0	0.0	0.0	1.0	0.0
Walk [s]	0	7	0	0	0	0	0	0	0	0	0	0
Pedestrian Clearance [s]	0	15	0	0	0	0	0	0	0	0	0	0
Delayed Vehicle Green [s]	0.0	0.0	0.0	0.0	0.0	0.0	0.0	0.0	0.0	0.0	0.0	0.0
Rest In Walk		No			No						No	
I1, Start-Up Lost Time [s]	0.0	2.0	0.0	0.0	2.0	0.0	0.0	0.0	0.0	0.0	2.0	2.0
I2, Clearance Lost Time [s]	0.0	2.0	0.0	0.0	2.0	0.0	0.0	0.0	0.0	0.0	2.0	2.0
Detector Location [ft]	0.0	0.0	0.0	0.0	0.0	0.0	0.0	0.0	0.0	0.0	0.0	0.0
Detector Length [ft]	0.0	20.0	0.0	0.0	20.0	0.0	0.0	0.0	0.0	0.0	20.0	20.0
I, Upstream Filtering Factor	1.00	1.00	1.00	1.00	1.00	1.00	1.00	1.00	1.00	1.00	1.00	1.00

**Phasing & Timing: Pattern 1**

Split [s]	0	68	0	0	83	0	0	0	0	0	22	15
Lead / Lag	-	-	-	-	-	-	-	-	-	-	-	-
Minimum Green [s]	0	11	0	0	8	0	0	0	0	0	4	4
Vehicle Extension [s]	0.0	0.0	0.0	0.0	0.0	0.0	0.0	0.0	0.0	0.0	0.0	0.0
Minimum Recall		Yes			Yes						No	No
Maximum Recall		No			No						No	No
Pedestrian Recall		No			No						No	No

**Exclusive Pedestrian Phase**

Pedestrian Signal Group	0
Pedestrian Walk [s]	0
Pedestrian Clearance [s]	0



**Lane Group Calculations**

Lane Group	C	C		L	C	R
C, Cycle Length [s]	105	105		105	105	105
L, Total Lost Time per Cycle [s]	4.00	4.00		4.00	4.00	4.00
l1_p, Permitted Start-Up Lost Time [s]	0.00	0.00		0.00	0.00	0.00
l2, Clearance Lost Time [s]	2.00	2.00		2.00	2.00	0.00
g_i, Effective Green Time [s]	74	87		10	10	23
g / C, Green / Cycle	0.71	0.83		0.09	0.09	0.22
(v / s)_i Volume / Saturation Flow Rate	0.32	0.18		0.02	0.02	0.09
s, saturation flow rate [veh/h]	3583	5159		1810	1810	2834
c, Capacity [veh/h]	2538	4283		169	169	637
d1, Uniform Delay [s]	6.57	1.85		43.78	43.78	34.55
k, delay calibration	0.50	0.50		0.04	0.04	0.04
l, Upstream Filtering Factor	1.00	1.00		1.00	1.00	1.00
d2, Incremental Delay [s]	0.59	0.12		0.17	0.17	0.14
d3, Initial Queue Delay [s]	0.00	0.00		0.00	0.00	0.00
Rp, platoon ratio	1.00	1.00		1.00	1.00	1.00
PF, progression factor	1.00	1.00		1.00	1.00	1.00

**Lane Group Results**

X, volume / capacity	0.45	0.22		0.17	0.17	0.39
d, Delay for Lane Group [s/veh]	7.15	1.96		43.95	43.95	34.69
Lane Group LOS	A	A		D	D	C
Critical Lane Group	Yes	No		No	No	Yes
50th-Percentile Queue Length [veh/ln]	4.59	0.66		0.67	0.67	2.61
50th-Percentile Queue Length [ft/ln]	114.71	16.51		16.75	16.75	65.24
95th-Percentile Queue Length [veh/ln]	8.10	1.19		1.21	1.21	4.70
95th-Percentile Queue Length [ft/ln]	202.53	29.72		30.15	30.15	117.43

**Movement, Approach, & Intersection Results**

d_M, Delay for Movement [s/veh]	0.00	7.15	0.00	0.00	1.96	0.00	0.00	0.00	0.00	0.00	43.95	43.95	34.69
Movement LOS		A			A						D	D	C
d_A, Approach Delay [s/veh]	5.95				1.03				0.00		36.42		
Approach LOS	A				A				A		D		
d_I, Intersection Delay [s/veh]	7.93												
Intersection LOS	A												
Intersection V/C	0.361												

**Emissions**

Vehicle Miles Traveled [mph]	96.01	111.02	2.80	2.80	24.49
Stops [stops/h]	314.81	67.96	22.98	22.98	179.04
Fuel consumption [US gal/h]	8.21	5.02	0.64	0.64	4.82
CO [g/h]	573.73	350.78	44.51	44.51	337.15
NOx [g/h]	111.63	68.25	8.66	8.66	65.60
VOC [g/h]	132.97	81.30	10.31	10.31	78.14

**Other Modes**

g_Walk,mi, Effective Walk Time [s]	0.0	0.0	0.0	11.0
M_corner, Corner Circulation Area [ft <sup>2</sup> /ped]	0.00	0.00	0.00	0.00
M_CW, Crosswalk Circulation Area [ft <sup>2</sup> /ped]	0.00	0.00	0.00	0.00
d_p, Pedestrian Delay [s]	0.00	0.00	0.00	42.05
I_p,int, Pedestrian LOS Score for Intersectio	0.000	0.000	0.000	2.397
Crosswalk LOS	F	F	F	B
s_b, Saturation Flow Rate of the bicycle lane	2000	2000	2000	2000
c_b, Capacity of the bicycle lane [bicycles/h]	1195	1481	0	343
d_b, Bicycle Delay [s]	8.51	3.54	52.47	36.01
I_b,int, Bicycle LOS Score for Intersection	2.509	2.074	4.132	2.065
Bicycle LOS	B	B	D	B

**Sequence**

Ring 1	1	2	-	-	-	-	-	-	-	-	-	-	-	-	-
Ring 2	-	6	-	8	-	-	-	-	-	-	-	-	-	-	-
Ring 3	-	-	-	-	-	-	-	-	-	-	-	-	-	-	-
Ring 4	-	-	-	-	-	-	-	-	-	-	-	-	-	-	-



**Intersection Level Of Service Report**  
**Intersection 20: Croak Road & Central Parkway**

Control Type:	All-way stop	Delay (sec / veh):	13.5
Analysis Method:	HCM 7th Edition	Level Of Service:	B
Analysis Period:	15 minutes	Volume to Capacity (v/c):	0.591

**Intersection Setup**

Name	Croak Road			Croak Road			Central Parkway			Westbound		
Approach	Northbound			Southbound			Eastbound			Westbound		
Lane Configuration	+			+			+			+		
Turning Movement	Left	Thru	Right	Left	Thru	Right	Left	Thru	Right	Left	Thru	Right
Lane Width [ft]	12.00	12.00	12.00	12.00	12.00	12.00	12.00	12.00	12.00	12.00	12.00	12.00
No. of Lanes in Entry Pocket	0	0	0	0	0	0	0	0	0	0	0	0
Entry Pocket Length [ft]	100.00	100.00	100.00	100.00	100.00	100.00	100.00	100.00	100.00	100.00	100.00	100.00
No. of Lanes in Exit Pocket	0	0	0	0	0	0	0	0	0	0	0	0
Exit Pocket Length [ft]	0.00	0.00	0.00	0.00	0.00	0.00	0.00	0.00	0.00	0.00	0.00	0.00
Speed [mph]	30.00			30.00			25.00			30.00		
Grade [%]	0.00			0.00			0.00			0.00		
Crosswalk	Yes			Yes			Yes			Yes		

**Volumes**

Name	Croak Road			Croak Road			Central Parkway			Westbound		
Base Volume Input [veh/h]	40	113	26	0	69	107	185	180	20	15	241	0
Base Volume Adjustment Factor	1.0000	1.0000	1.0000	1.0000	1.0000	1.0000	1.0000	1.0000	1.0000	1.0000	1.0000	1.0000
Heavy Vehicles Percentage [%]	2.00	2.00	2.00	2.00	2.00	2.00	2.00	2.00	2.00	2.00	2.00	2.00
Growth Factor	1.0000	1.0000	1.0000	1.0000	1.0000	1.0000	1.0000	1.0000	1.0000	1.0000	1.0000	1.0000
In-Process Volume [veh/h]	0	0	0	0	0	0	0	0	0	0	0	0
Site-Generated Trips [veh/h]	0	0	0	0	0	0	0	0	0	0	0	0
Diverted Trips [veh/h]	0	0	0	0	0	0	0	0	0	0	0	0
Pass-by Trips [veh/h]	0	0	0	0	0	0	0	0	0	0	0	0
Existing Site Adjustment Volume [veh/h]	0	0	0	0	0	0	0	0	0	0	0	0
Other Volume [veh/h]	0	0	0	0	0	0	0	0	0	0	0	0
Total Hourly Volume [veh/h]	40	113	26	0	69	107	185	180	20	15	241	0
Peak Hour Factor	1.0000	1.0000	1.0000	1.0000	1.0000	1.0000	1.0000	1.0000	1.0000	1.0000	1.0000	1.0000
Other Adjustment Factor	1.0000	1.0000	1.0000	1.0000	1.0000	1.0000	1.0000	1.0000	1.0000	1.0000	1.0000	1.0000
Total 15-Minute Volume [veh/h]	10	28	7	0	17	27	46	45	5	4	60	0
Total Analysis Volume [veh/h]	40	113	26	0	69	107	185	180	20	15	241	0
Pedestrian Volume [ped/h]	0			0			0			0		



**Intersection Settings****Lanes**

Capacity per Entry Lane [veh/h]	594	625	652	633
Degree of Utilization, x	0.30	0.28	0.59	0.40

**Movement, Approach, & Intersection Results**

95th-Percentile Queue Length [veh]	1.26	1.15	3.88	1.96
95th-Percentile Queue Length [ft]	31.59	28.82	97.09	48.93
Approach Delay [s/veh]	11.66	11.01	16.20	12.50
Approach LOS	B	B	C	B
Intersection Delay [s/veh]	13.51			
Intersection LOS	B			

**Intersection Level Of Service Report**  
**Intersection 22: Croak Road & Dublin Boulevard**

Control Type:	Signalized	Delay (sec / veh):	18.8
Analysis Method:	HCM 7th Edition	Level Of Service:	B
Analysis Period:	15 minutes	Volume to Capacity (v/c):	0.637

**Intersection Setup**

Name	Croak Road			Croak Road			Dublin Boulevard			Dublin Boulevard		
Approach	Northbound			Southbound			Eastbound			Westbound		
Lane Configuration												
Turning Movement	Left	Thru	Right	Left	Thru	Right	Left	Thru	Right	Left	Thru	Right
Lane Width [ft]	12.00	12.00	12.00	12.00	12.00	12.00	12.00	12.00	12.00	12.00	12.00	12.00
No. of Lanes in Entry Pocket	1	0	0	1	0	1	1	0	1	1	0	1
Entry Pocket Length [ft]	100.00	100.00	100.00	100.00	100.00	100.00	210.00	100.00	250.00	150.00	100.00	250.00
No. of Lanes in Exit Pocket	0	0	0	0	0	0	0	0	0	0	0	0
Exit Pocket Length [ft]	0.00	0.00	0.00	0.00	0.00	0.00	0.00	0.00	0.00	0.00	0.00	0.00
Speed [mph]	30.00			30.00			30.00			30.00		
Grade [%]	0.00			0.00			0.00			0.00		
Curb Present	No			No			No			No		
Crosswalk	Yes			Yes			Yes			Yes		



**Volumes**

Name	Croak Road			Croak Road			Dublin Boulevard			Dublin Boulevard		
Base Volume Input [veh/h]	0	0	0	8	0	0	33	2077	0	2	248	31
Base Volume Adjustment Factor	1.0000	1.0000	1.0000	1.0000	1.0000	1.0000	1.0000	1.0000	1.0000	1.0000	1.0000	1.0000
Heavy Vehicles Percentage [%]	2.00	2.00	2.00	2.00	2.00	2.00	2.00	2.00	2.00	2.00	2.00	2.00
Proportion of CAVs [%]	0.00											
Growth Factor	1.0000	1.0000	1.0000	1.0000	1.0000	1.0000	1.0000	1.0000	1.0000	1.0000	1.0000	1.0000
In-Process Volume [veh/h]	0	0	0	0	0	0	0	0	0	0	0	0
Site-Generated Trips [veh/h]	0	0	0	0	0	0	0	0	0	0	0	0
Diverted Trips [veh/h]	0	0	0	0	0	0	0	0	0	0	0	0
Pass-by Trips [veh/h]	0	0	0	0	0	0	0	0	0	0	0	0
Existing Site Adjustment Volume [veh/h]	0	0	0	0	0	0	0	0	0	0	0	0
Other Volume [veh/h]	0	0	0	0	0	0	0	0	0	0	0	0
Right Turn on Red Volume [veh/h]	0	0	0	0	0	0	0	0	0	0	0	0
Total Hourly Volume [veh/h]	0	0	0	8	0	0	33	2077	0	2	248	31
Peak Hour Factor	1.0000	1.0000	1.0000	1.0000	1.0000	1.0000	1.0000	1.0000	1.0000	1.0000	1.0000	1.0000
Other Adjustment Factor	1.0000	1.0000	1.0000	1.0000	1.0000	1.0000	1.0000	1.0000	1.0000	1.0000	1.0000	1.0000
Total 15-Minute Volume [veh/h]	0	0	0	2	0	0	8	519	0	1	62	8
Total Analysis Volume [veh/h]	0	0	0	8	0	0	33	2077	0	2	248	31
Presence of On-Street Parking	No		No	No		No	No		No	No		No
On-Street Parking Maneuver Rate [/h]	0	0	0	0	0	0	0	0	0	0	0	0
Local Bus Stopping Rate [/h]	0	0	0	0	0	0	0	0	0	0	0	0
v_do, Outbound Pedestrian Volume crossing	0			0			0			0		
v_di, Inbound Pedestrian Volume crossing m	0			0			0			0		
v_co, Outbound Pedestrian Volume crossing	0			0			0			0		
v_ci, Inbound Pedestrian Volume crossing mi	0			0			0			0		
v_ab, Corner Pedestrian Volume [ped/h]	0			0			0			0		
Bicycle Volume [bicycles/h]	0			0			0			0		





**Intersection Settings**

Located in CBD	No
Signal Coordination Group	-
Cycle Length [s]	160
Active Pattern	Pattern 1
Coordination Type	Time of Day Pattern Isolated
Actuation Type	Fully actuated
Offset [s]	0.0
Offset Reference	Lead Green - Beginning of First Green
Permissive Mode	SingleBand
Lost time [s]	12.00

**Phasing & Timing (Basic)**

Control Type	Protecte	Permiss	Permiss	Protecte	Permiss	Permiss	Protecte	Permiss	Permiss	Protecte	Permiss	Permiss
Signal Group	1	6	0	5	2	0	3	8	0	7	4	0
Auxiliary Signal Groups												
Maximum Green [s]	5	26	0	5	26	0	5	126	0	5	126	0
Amber [s]	3.0	3.0	0.0	3.0	3.0	0.0	3.0	3.0	0.0	3.0	3.0	0.0
All red [s]	1.0	1.0	0.0	1.0	1.0	0.0	1.0	1.0	0.0	1.0	1.0	0.0
Walk [s]	0	5	0	0	5	0	0	5	0	0	5	0
Pedestrian Clearance [s]	0	21	0	0	21	0	0	10	0	0	10	0
Delayed Vehicle Green [s]	0.0	0.0	0.0	0.0	0.0	0.0	0.0	0.0	0.0	0.0	0.0	0.0
Rest In Walk		No			No			No			No	
I1, Start-Up Lost Time [s]	2.0	2.0	0.0	2.0	2.0	0.0	2.0	2.0	0.0	2.0	2.0	0.0
I2, Clearance Lost Time [s]	2.0	2.0	0.0	2.0	2.0	0.0	2.0	2.0	0.0	2.0	2.0	0.0
Detector Location [ft]	0.0	0.0	0.0	0.0	0.0	0.0	0.0	0.0	0.0	0.0	0.0	0.0
Detector Length [ft]	20.0	20.0	0.0	0.0	0.0	0.0	20.0	20.0	0.0	20.0	20.0	0.0
I, Upstream Filtering Factor	1.00	1.00	1.00	1.00	1.00	1.00	1.00	1.00	1.00	1.00	1.00	1.00

**Phasing & Timing: Pattern 1**

Split [s]	9	30	0	9	30	0	38	97	0	24	83	0
Lead / Lag	Lead	-	-	Lead	-	-	Lead	-	-	Lead	-	-
Minimum Green [s]	5	10	0	5	10	0	5	10	0	5	10	0
Vehicle Extension [s]	3.0	3.0	0.0	3.0	3.0	0.0	3.0	3.0	0.0	3.0	3.0	0.0
Minimum Recall	No	No		No	No		No	No		No	No	
Maximum Recall	No	No		No	No		No	No		No	No	
Pedestrian Recall	No	No		No	No		No	No		No	No	

**Exclusive Pedestrian Phase**

Pedestrian Signal Group	0
Pedestrian Walk [s]	0
Pedestrian Clearance [s]	0



**Lane Group Calculations**

Lane Group	L	C	L	C	R	L	C	R	L	C	R
C, Cycle Length [s]	160	160	160	160	160	160	160	160	160	160	160
L, Total Lost Time per Cycle [s]	4.00	4.00	4.00	4.00	4.00	4.00	4.00	4.00	4.00	4.00	4.00
l1_p, Permitted Start-Up Lost Time [s]	0.00	0.00	0.00	0.00	0.00	0.00	0.00	0.00	0.00	0.00	0.00
l2, Clearance Lost Time [s]	2.00	2.00	2.00	2.00	2.00	2.00	2.00	2.00	2.00	2.00	2.00
g_i, Effective Green Time [s]	0	30	2	32	32	4	112	112	0	108	108
g / C, Green / Cycle	0.00	0.19	0.01	0.20	0.20	0.02	0.70	0.70	0.00	0.68	0.68
(v / s)_i Volume / Saturation Flow Rate	0.00	0.00	0.00	0.00	0.00	0.02	0.58	0.00	0.00	0.07	0.02
s, saturation flow rate [veh/h]	1781	1870	1781	1870	1589	1781	3560	1589	1781	3560	1589
c, Capacity [veh/h]	0	356	17	373	317	43	2483	1108	5	2407	1074
d1, Uniform Delay [s]	0.00	0.00	78.90	0.00	0.00	77.68	17.61	0.00	79.70	9.04	8.57
k, delay calibration	0.11	0.50	0.11	0.50	0.50	0.11	0.11	0.11	0.11	0.11	0.11
l, Upstream Filtering Factor	1.00	1.00	1.00	1.00	1.00	1.00	1.00	1.00	1.00	1.00	1.00
d2, Incremental Delay [s]	0.00	0.00	18.80	0.00	0.00	23.91	0.79	0.00	41.63	0.02	0.01
d3, Initial Queue Delay [s]	0.00	0.00	0.00	0.00	0.00	0.00	0.00	0.00	0.00	0.00	0.00
Rp, platoon ratio	1.00	1.00	1.00	1.00	1.00	1.00	1.00	1.00	1.00	1.00	1.00
PF, progression factor	1.00	1.00	1.00	1.00	1.00	1.00	1.00	1.00	1.00	1.00	1.00

**Lane Group Results**

X, volume / capacity	0.00	0.00	0.47	0.00	0.00	0.76	0.84	0.00	0.39	0.10	0.03
d, Delay for Lane Group [s/veh]	0.00	0.00	97.70	0.00	0.00	101.59	18.40	0.00	121.33	9.06	8.59
Lane Group LOS	A	A	F	A	A	F	B	A	F	A	A
Critical Lane Group	No	No	Yes	No	No	No	Yes	No	Yes	No	No
50th-Percentile Queue Length [veh/ln]	0.00	0.00	0.42	0.00	0.00	1.65	26.58	0.00	0.14	1.54	0.37
50th-Percentile Queue Length [ft/ln]	0.00	0.00	10.49	0.00	0.00	41.21	664.39	0.00	3.56	38.48	9.17
95th-Percentile Queue Length [veh/ln]	0.00	0.00	0.76	0.00	0.00	2.97	35.03	0.00	0.26	2.77	0.66
95th-Percentile Queue Length [ft/ln]	0.00	0.00	18.88	0.00	0.00	74.18	875.75	0.00	6.42	69.27	16.51



**Movement, Approach, & Intersection Results**

d_M, Delay for Movement [s/veh]	0.00	0.00	0.00	97.70	0.00	0.00	101.59	18.40	0.00	121.33	9.06	8.59
Movement LOS	A	A	A	F	A	A	F	B	A	F	A	A
d_A, Approach Delay [s/veh]	0.00			97.70			19.70			9.80		
Approach LOS	A			F			B			A		
d_I, Intersection Delay [s/veh]	18.80											
Intersection LOS	B											
Intersection V/C	0.637											

**Emissions**

Vehicle Miles Traveled [mph]	0.00	0.00	1.88	0.00	0.00	10.17	640.22	0.00	0.05	5.89	0.74
Stops [stops/h]	0.00	0.00	9.44	0.00	0.00	37.08	1195.37	0.00	3.21	69.24	8.25
Fuel consumption [US gal/h]	0.00	0.00	0.29	0.00	0.00	1.31	40.74	0.00	0.07	1.08	0.13
CO [g/h]	0.00	0.00	20.18	0.00	0.00	91.27	2847.61	0.00	4.83	75.62	9.09
NOx [g/h]	0.00	0.00	3.93	0.00	0.00	17.76	554.04	0.00	0.94	14.71	1.77
VOC [g/h]	0.00	0.00	4.68	0.00	0.00	21.15	659.96	0.00	1.12	17.53	2.11

**Other Modes**

g_Walk,mi, Effective Walk Time [s]	9.0	9.0	9.0	9.0
M_corner, Corner Circulation Area [ft <sup>2</sup> /ped]	0.00	0.00	0.00	0.00
M_CW, Crosswalk Circulation Area [ft <sup>2</sup> /ped]	0.00	0.00	0.00	0.00
d_p, Pedestrian Delay [s]	71.29	71.29	71.29	71.29
I_p,int, Pedestrian LOS Score for Intersectio	1.969	2.177	2.864	2.866
Crosswalk LOS	A	B	C	C
s_b, Saturation Flow Rate of the bicycle lane	2000	2000	2000	2000
c_b, Capacity of the bicycle lane [bicycles/h]	325	325	1162	987
d_b, Bicycle Delay [s]	56.15	56.15	14.05	20.53
I_b,int, Bicycle LOS Score for Intersection	1.560	1.573	3.300	1.791
Bicycle LOS	A	A	C	A

**Sequence**

Ring 1	1	2	3	4	-	-	-	-	-	-	-	-	-	-	-
Ring 2	5	6	7	8	-	-	-	-	-	-	-	-	-	-	-
Ring 3	-	-	-	-	-	-	-	-	-	-	-	-	-	-	-
Ring 4	-	-	-	-	-	-	-	-	-	-	-	-	-	-	-

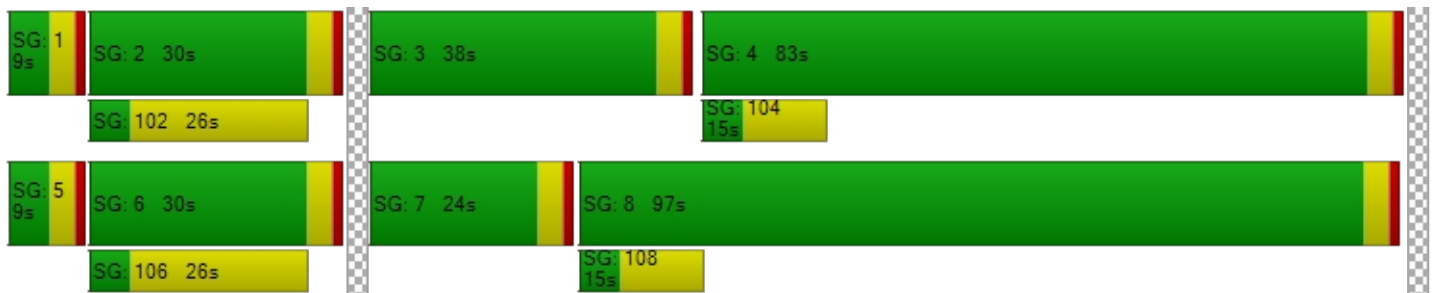



## Appendix J: Cumulative Plus Project Volume & Geometry

Lane Configuration and Traffic Control

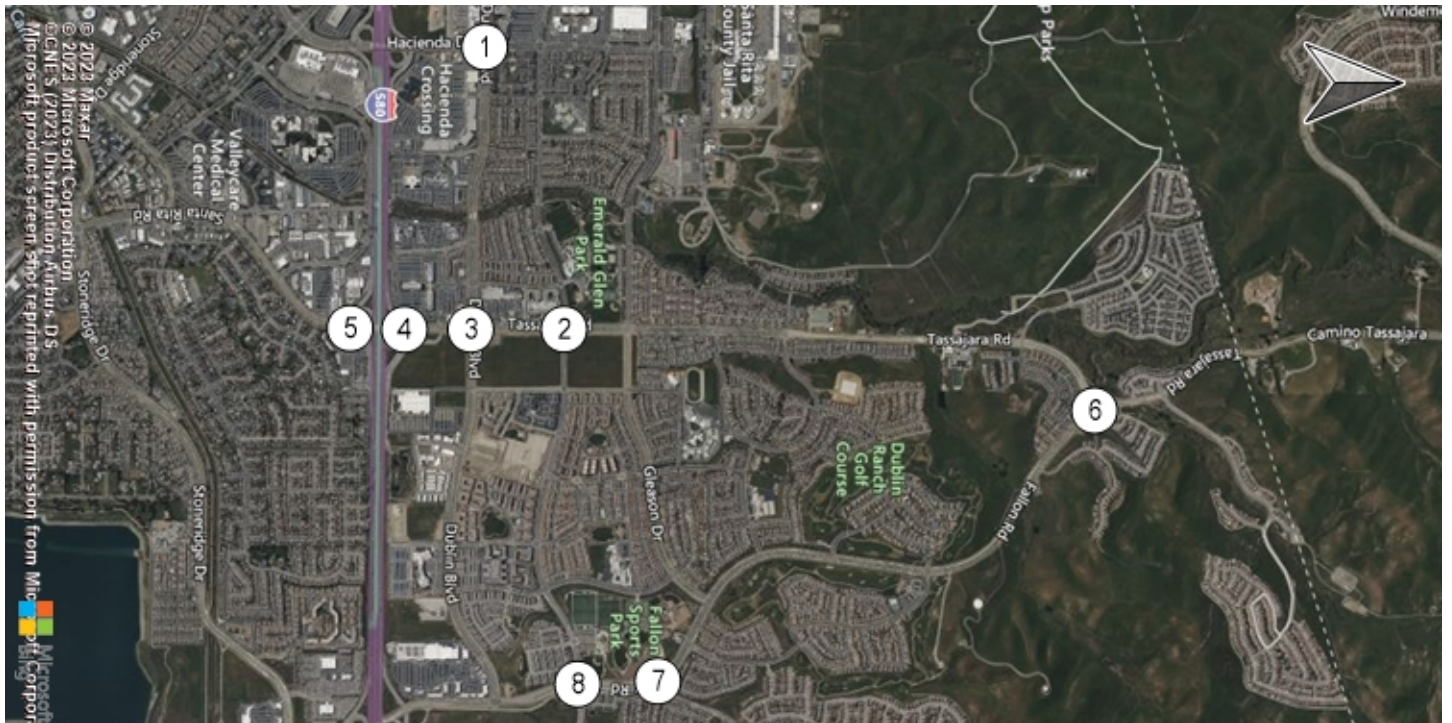

Hacienda Drive & Dublin Boul Tassajara Road & Central Pa Tassajara Road & Dublin Bou Tassajara Road & I-580 WB

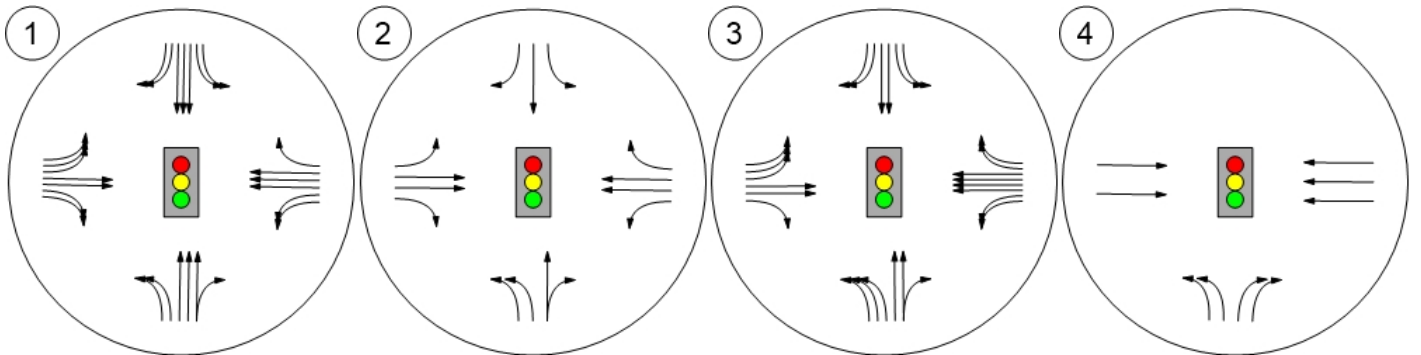

Santa Rita Rd & I-580 EB Ra Tassajara Road & Fallon Roa Fallon Road & Positano Park Fallon Road & Central Parkw

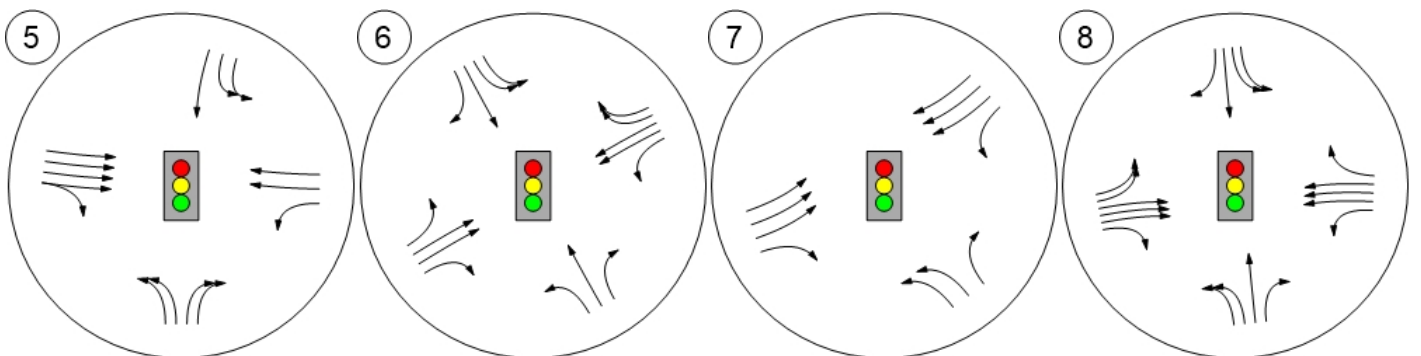



Lane Configuration and Traffic Control

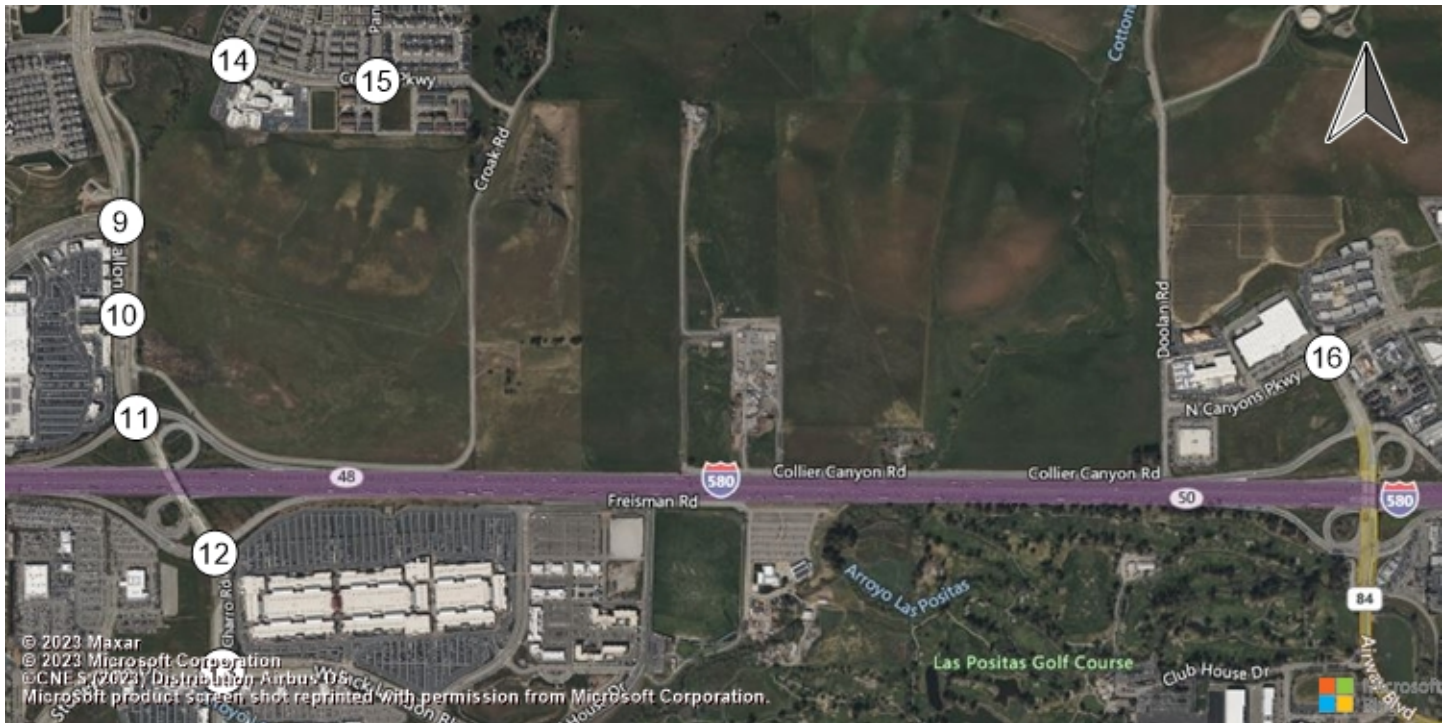

Fallon Road & Dublin Boulevard Fallon Road & Fallon Gateways Fallon Road & I-580 WB Ramp El Charro Road & I-580 EB R

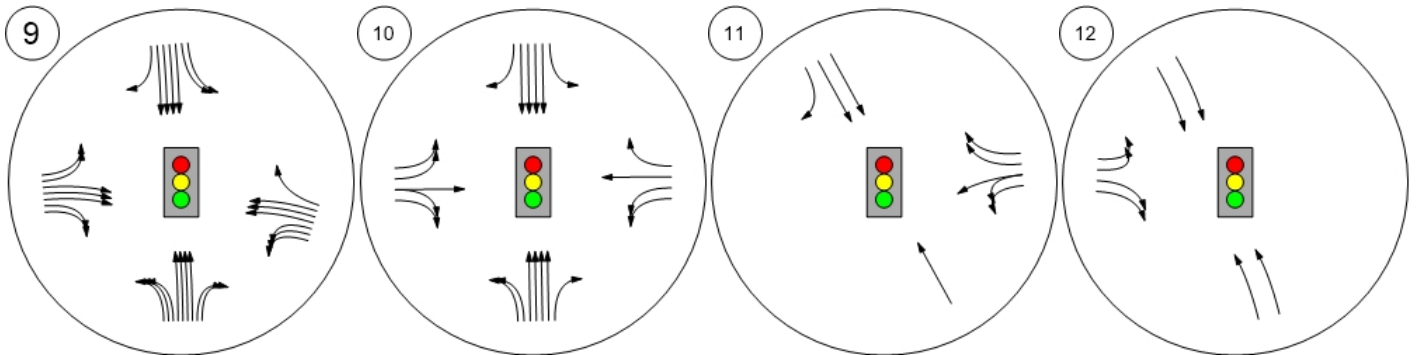

El Charro Road & Jack London Central Parkway & Sunset Vista Central Parkway & Panorama Airway Boulevard & N. Canyon

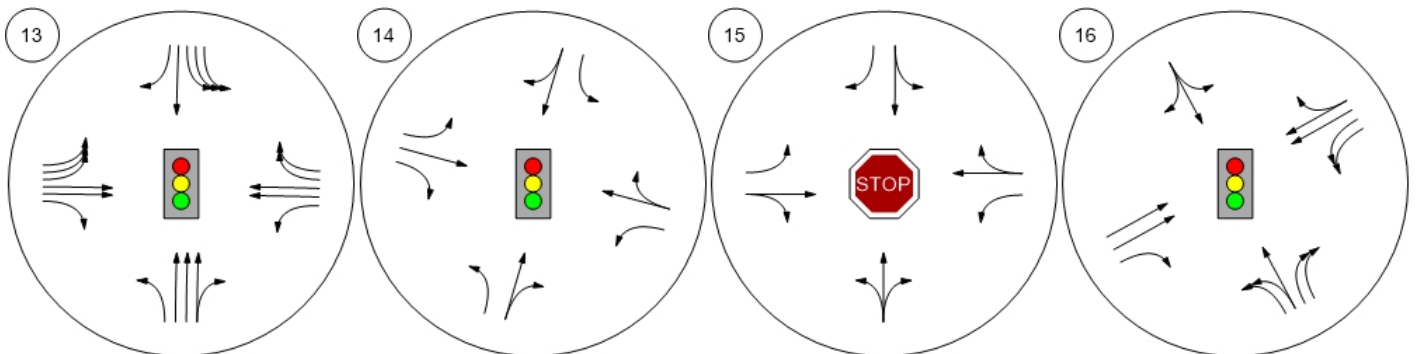

### Lane Configuration and Traffic Control

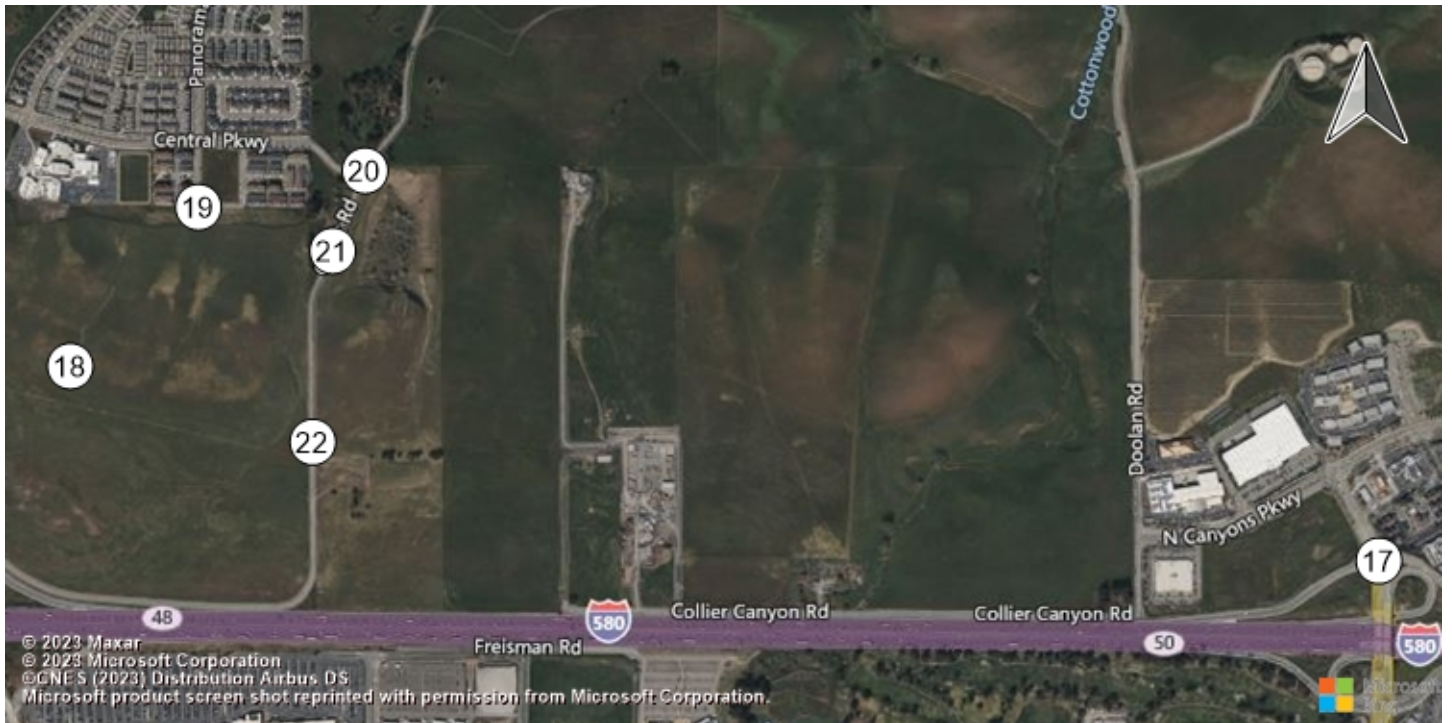

#### Airway Boulevard & I-580 WB Dublin Boulevard & Commercial Pandora Way & Residential P Croak Road & Central Parkw

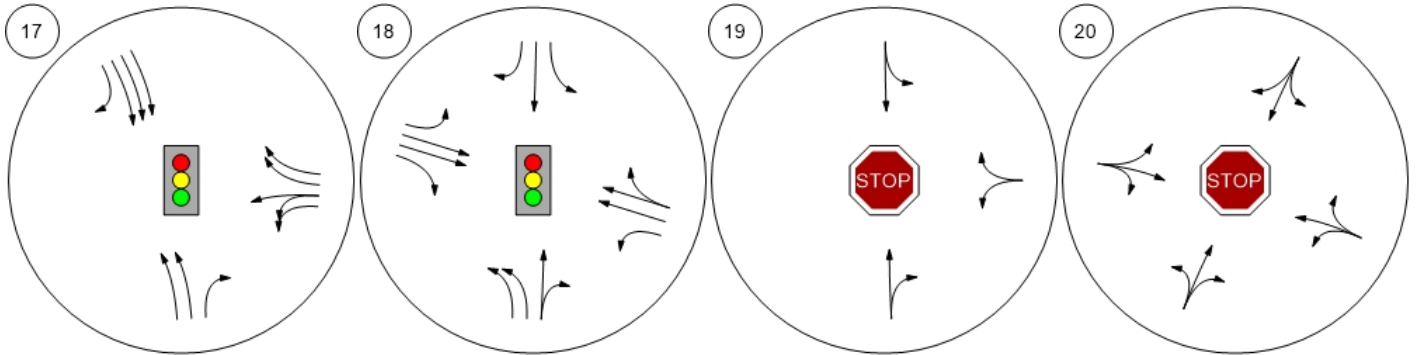

#### Croak Road & Project Access Croak Road & Dublin Boulev

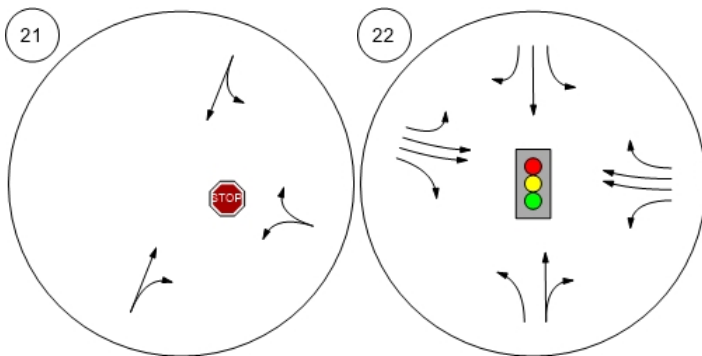



Traffic Volume - Base Volume

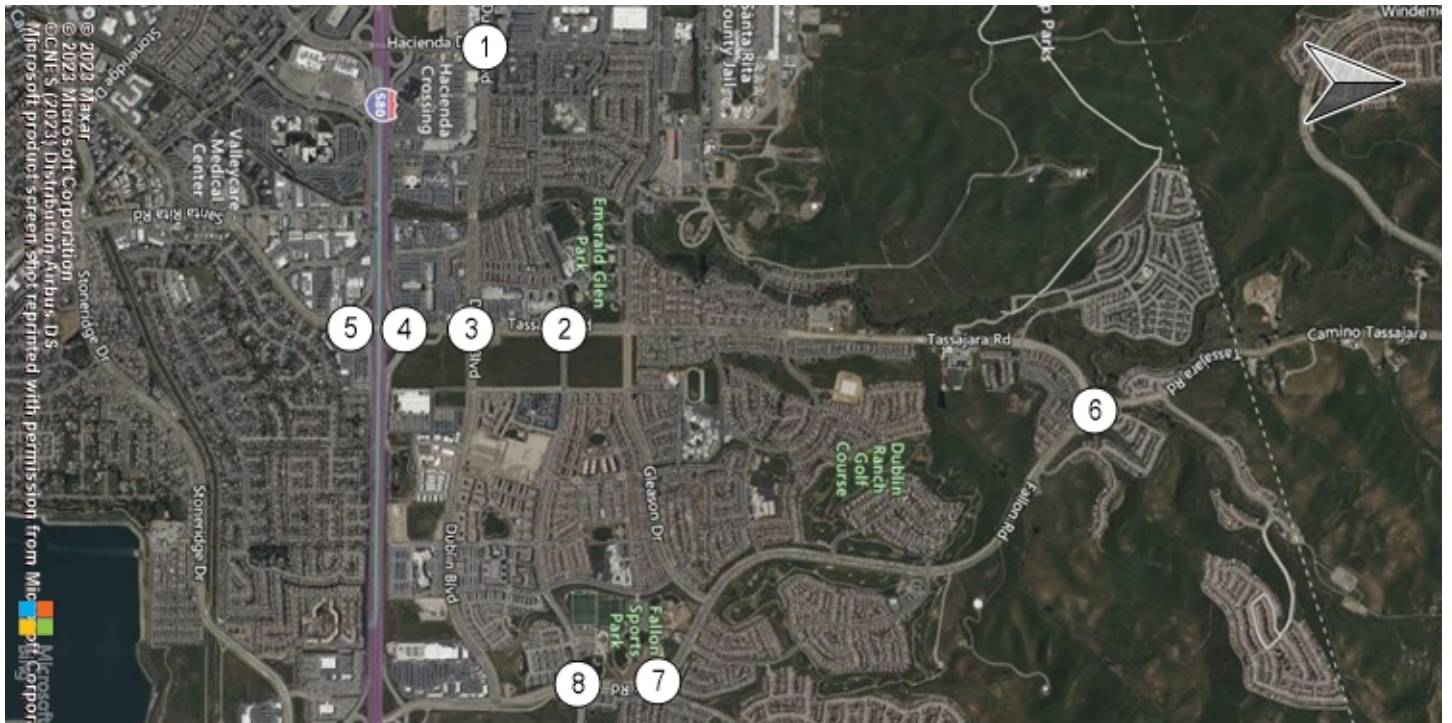

Hacienda Drive & Dublin Boul Tassajara Road & Central Pa Tassajara Road & Dublin Bou Tassajara Road & I-580 WB

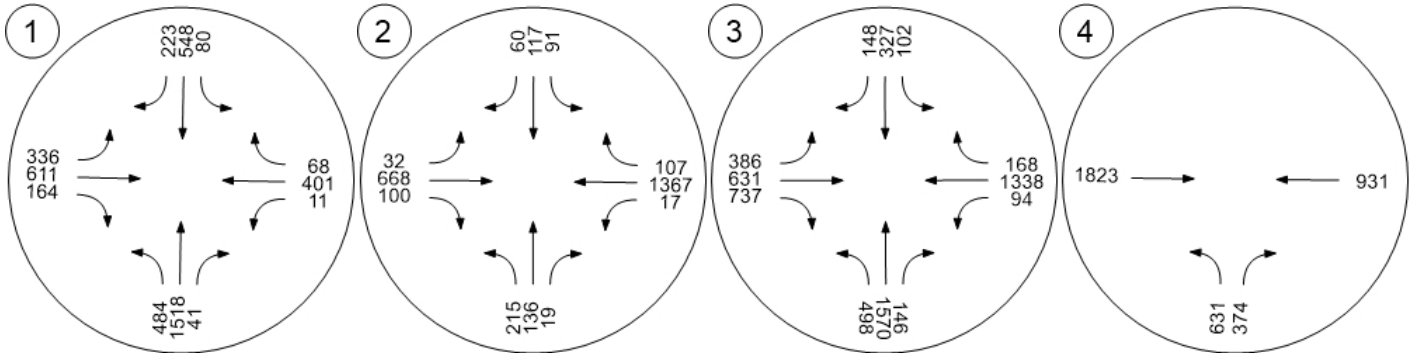

Santa Rita Rd & I-580 EB Ra Tassajara Road & Fallon Roa Fallon Road & Positano Park Fallon Road & Central Parkw

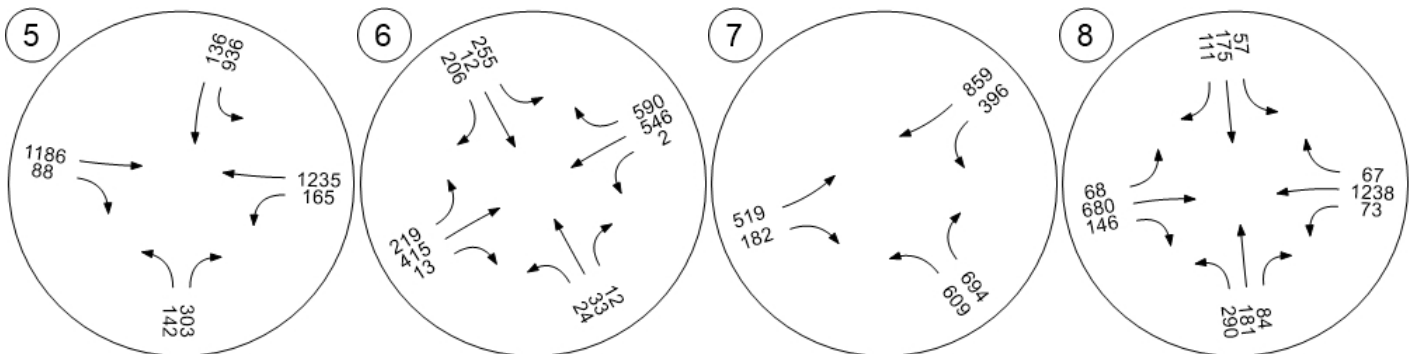



Traffic Volume - Base Volume

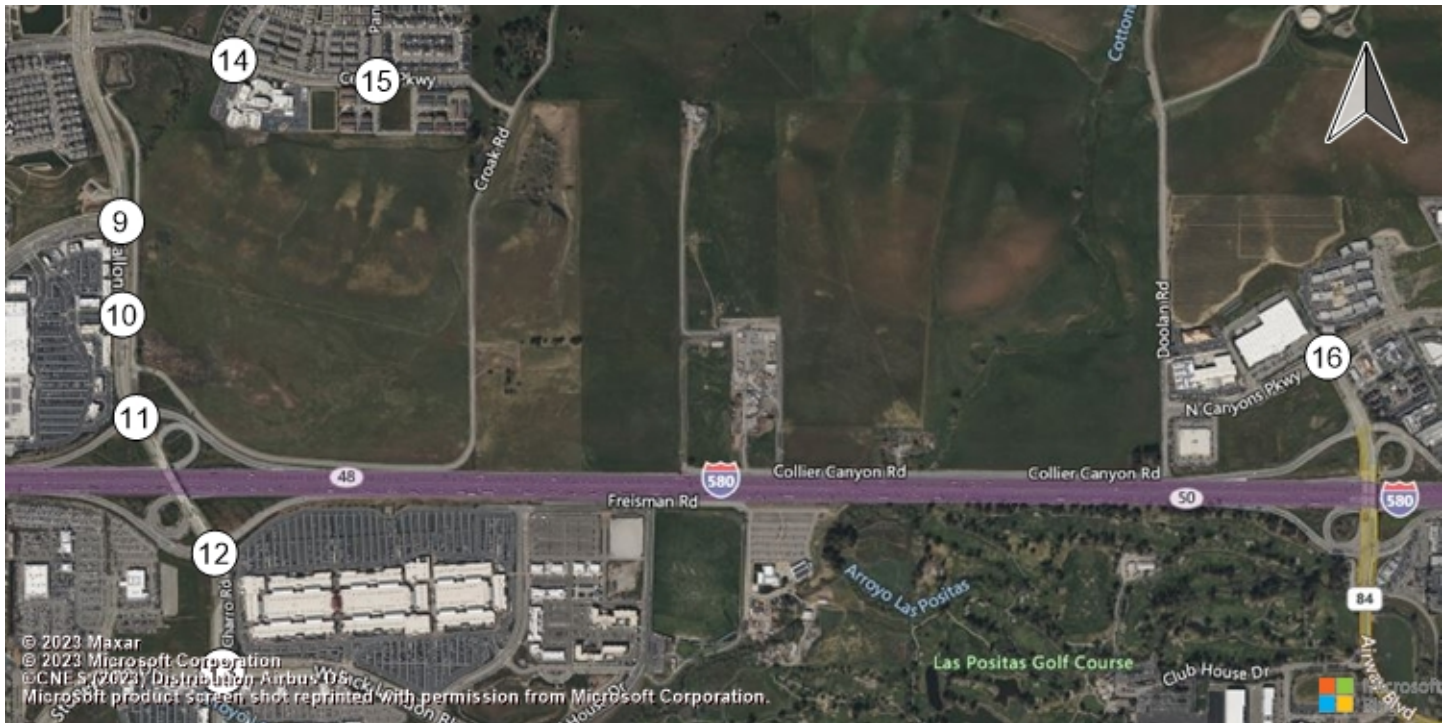

Fallon Road & Dublin Boulevard Fallon Road & Fallon Gateway Fallon Road & I-580 WB Ram El Charro Road & I-580 EB R

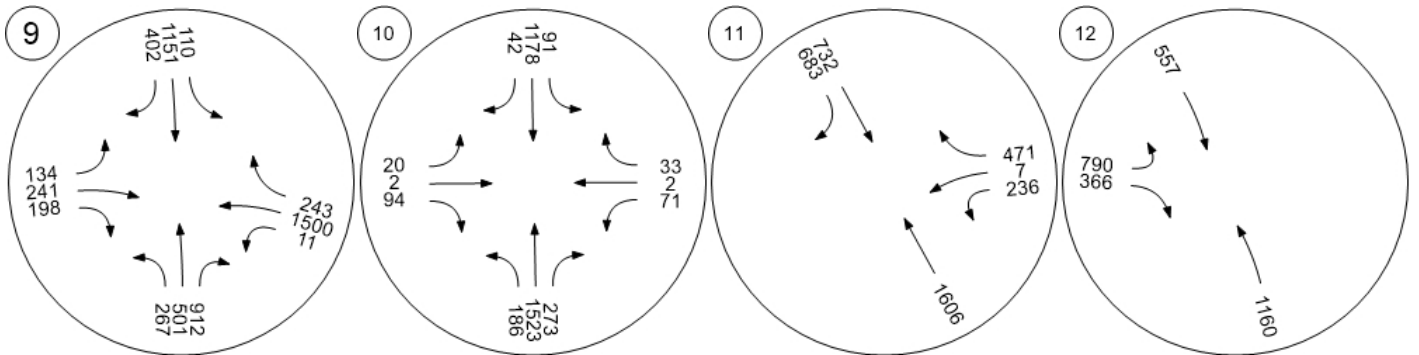

El Charro Road & Jack Lond Central Parkway & Sunset ViCentral Parkway & Panorama Airway Boulevard & N. Canyo

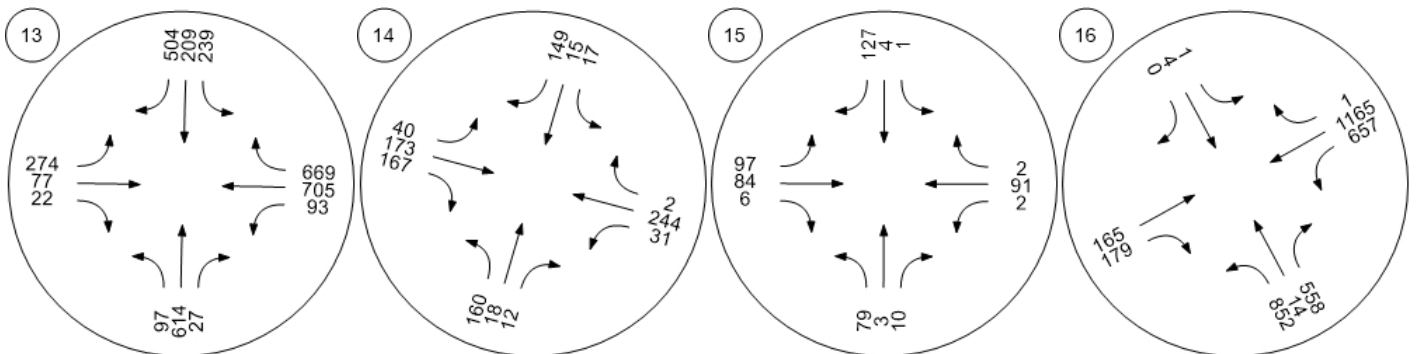

Traffic Volume - Base Volume

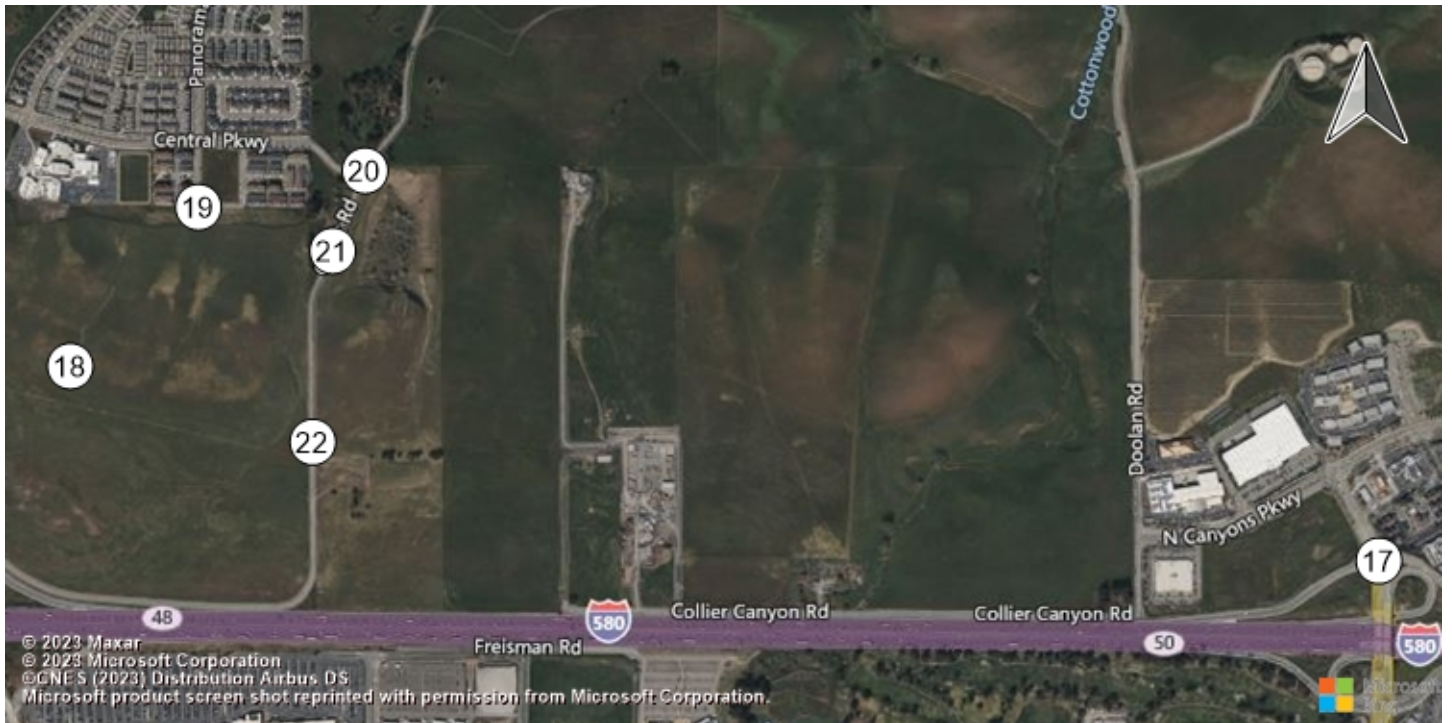

Airway Boulevard & I-580 WB Dublin Boulevard & Commercial Pandora Way & Residential P Croak Road & Central Parkw

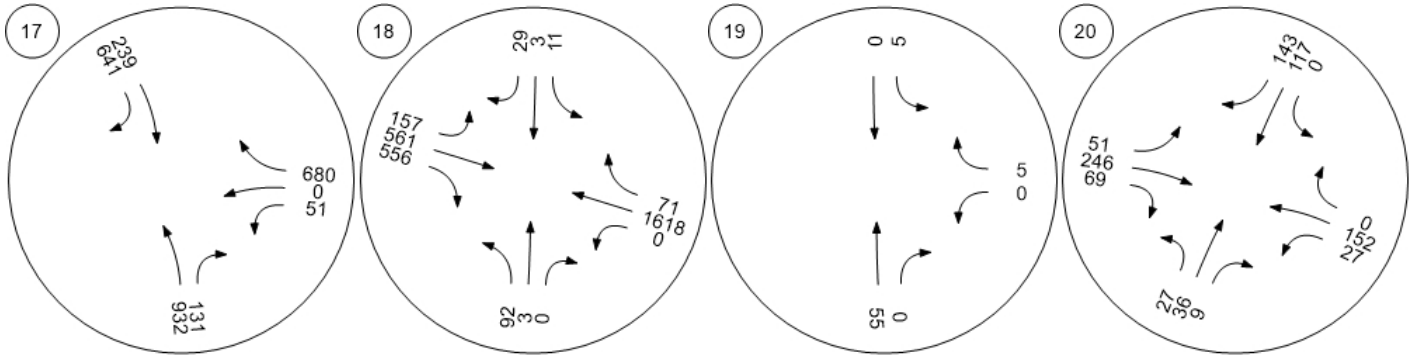

Croak Road & Project Access Croak Road & Dublin Boulev

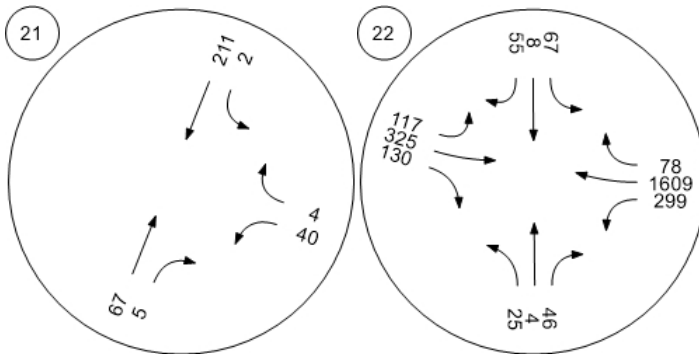



Lane Configuration and Traffic Control

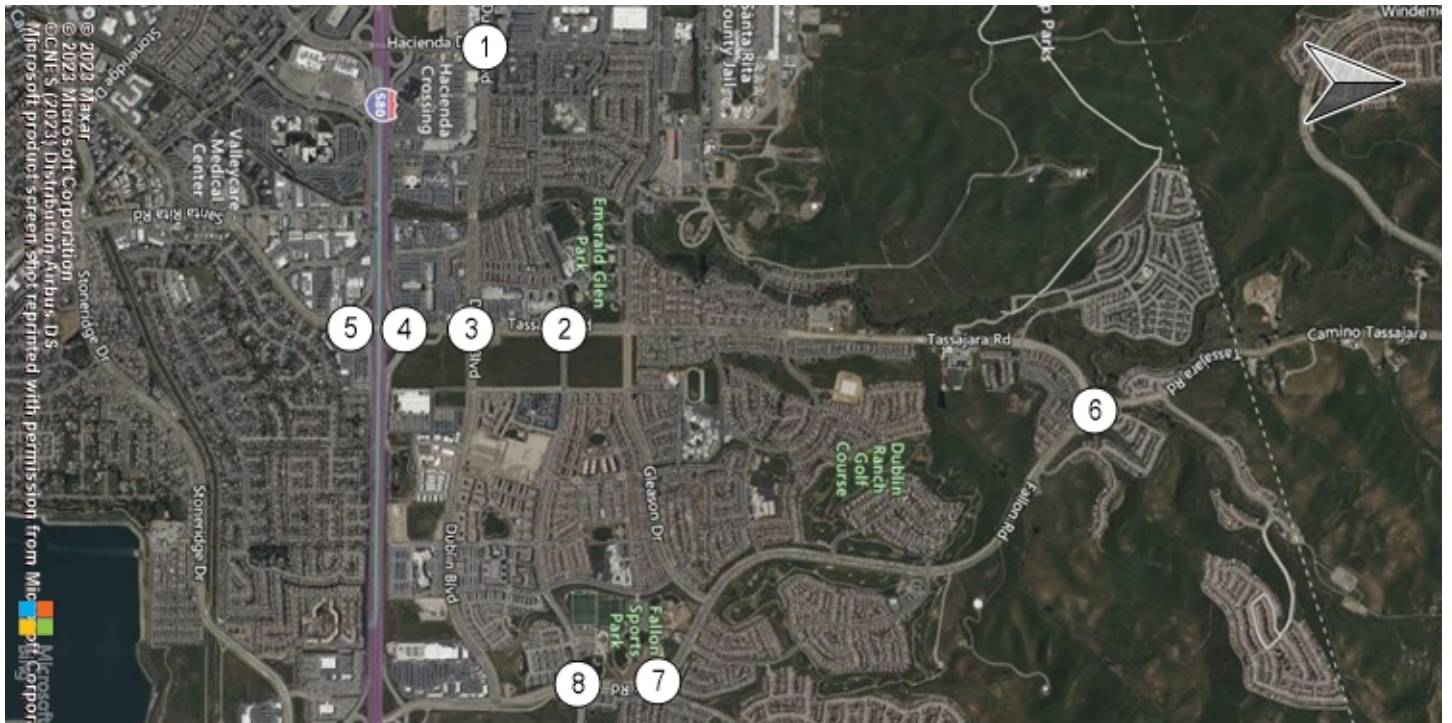

Hacienda Drive & Dublin Boul Tassajara Road & Central Pa Tassajara Road & Dublin Bou Tassajara Road & I-580 WB

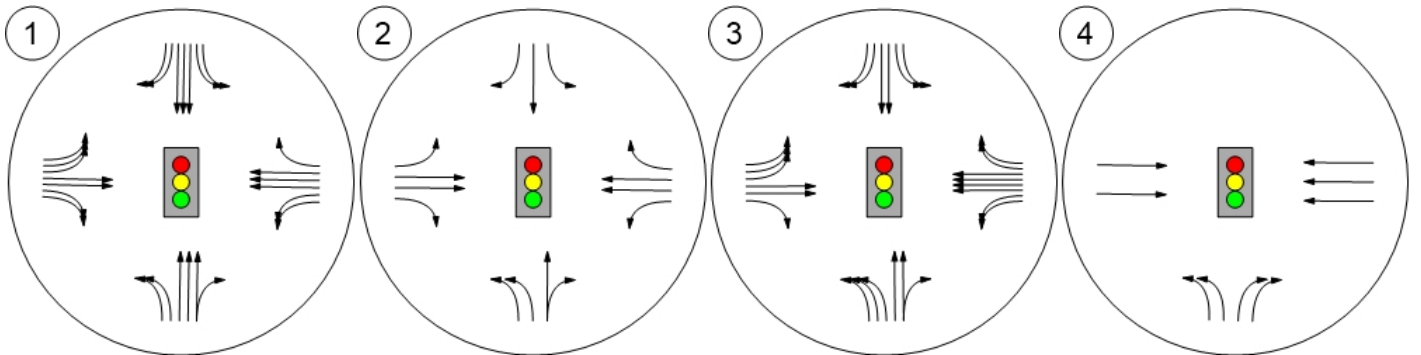

Santa Rita Rd & I-580 EB Ra Tassajara Road & Fallon Roa Fallon Road & Positano Park Fallon Road & Central Parkw

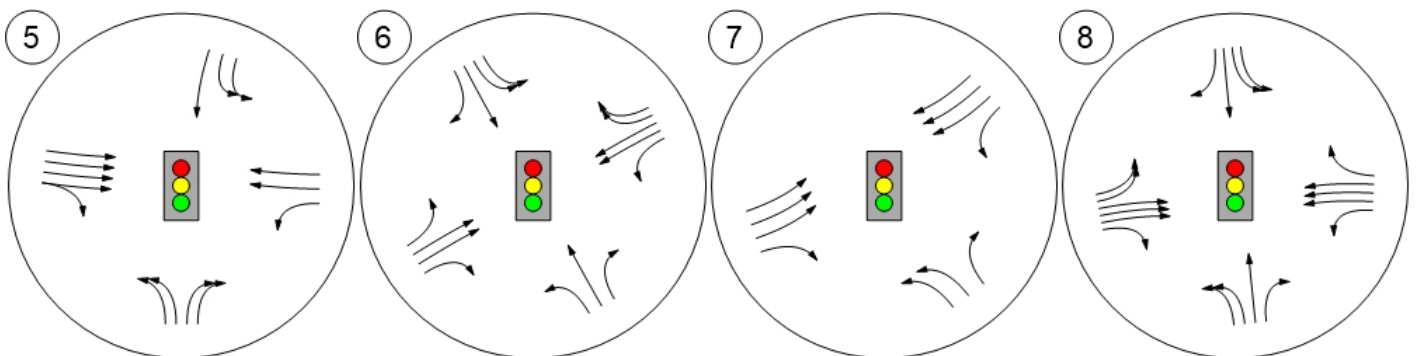

Lane Configuration and Traffic Control

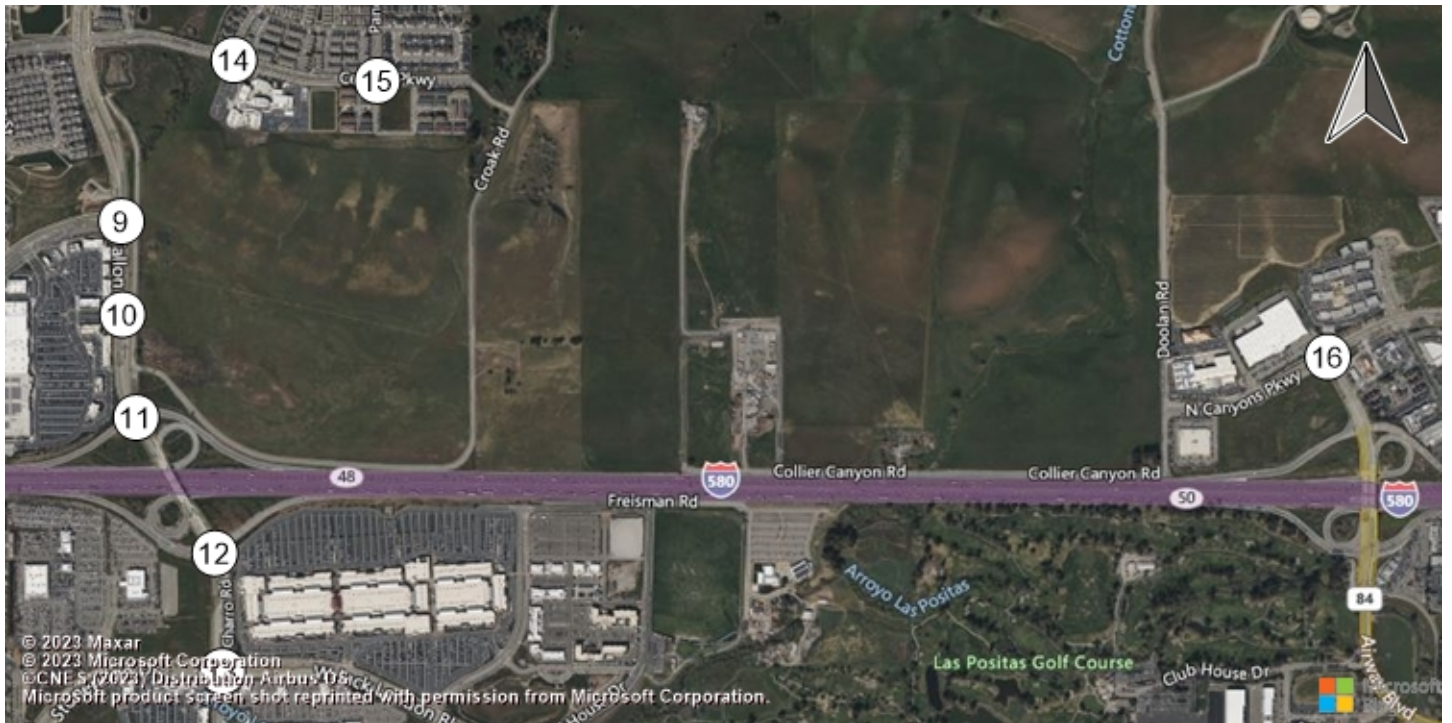

Fallon Road & Dublin Boulevard Fallon Road & Fallon Gateways Fallon Road & I-580 WB Ramp El Charro Road & I-580 EB Ramp

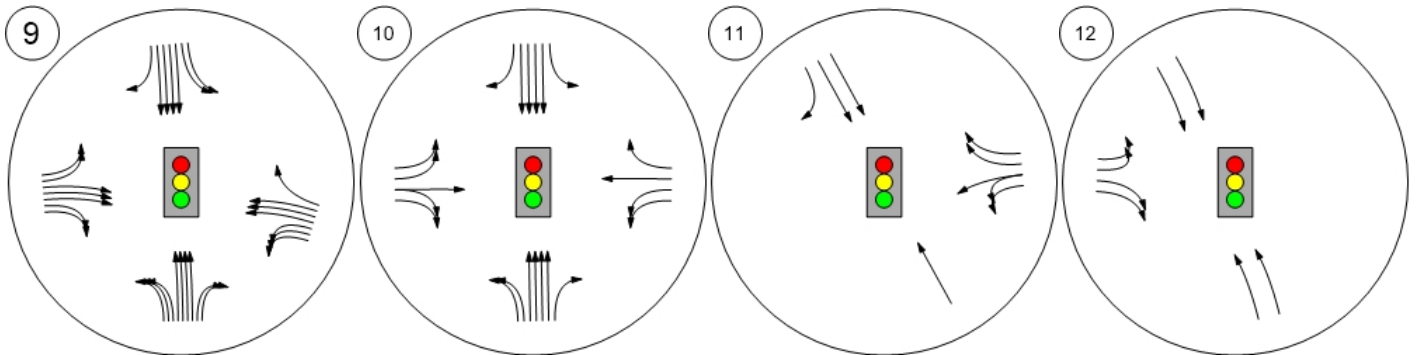

El Charro Road & Jack London Central Parkway & Sunset Vista Central Parkway & Panorama Airway Boulevard & N. Canyons

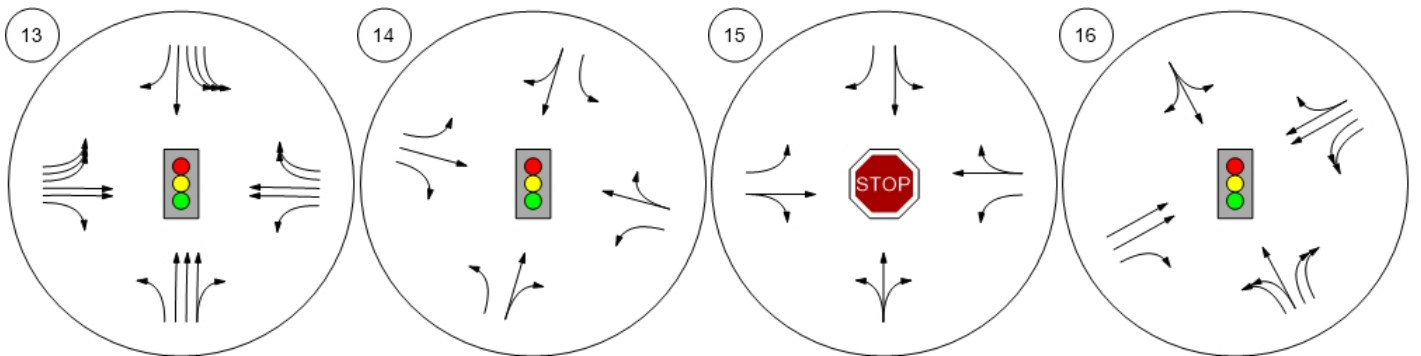



Lane Configuration and Traffic Control

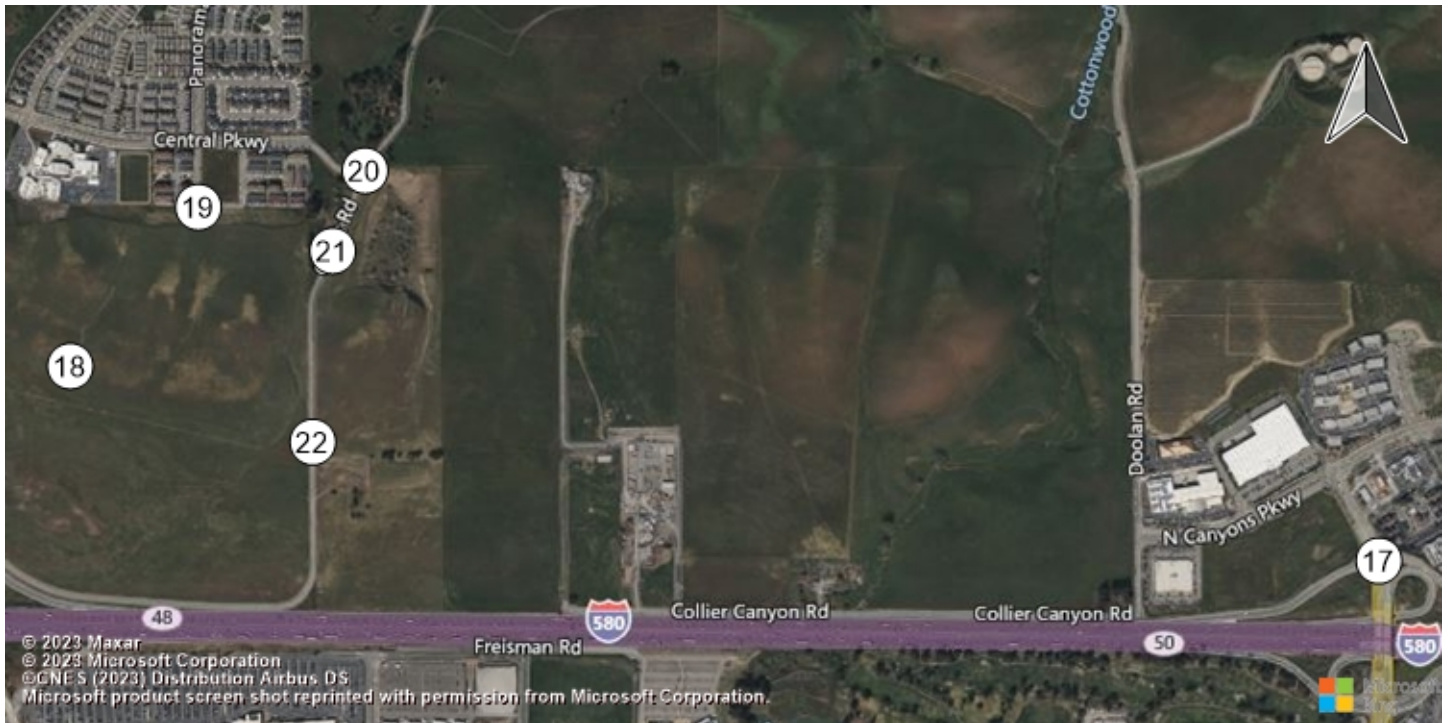

Airway Boulevard & I-580 WB Dublin Boulevard & Commercial Pandora Way & Residential P Croak Road & Central Parkw

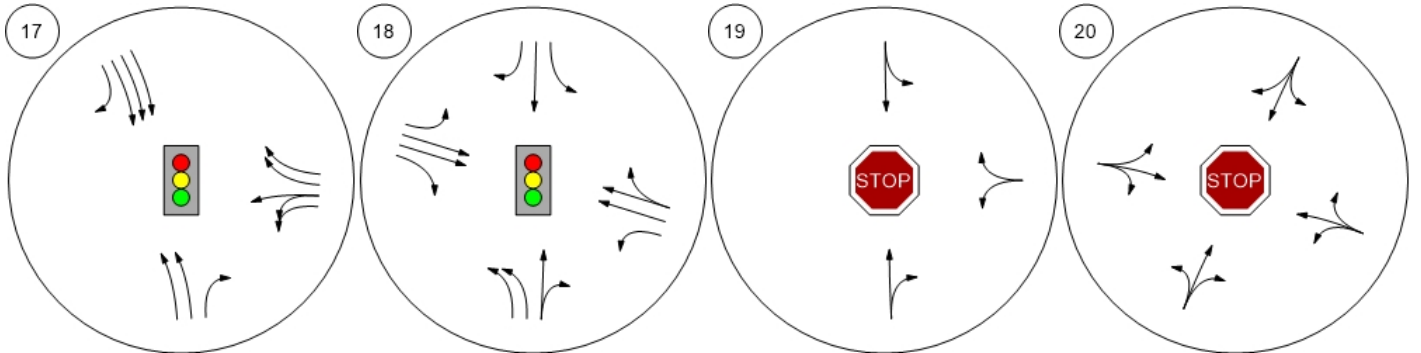

Croak Road & Project Access Croak Road & Dublin Boulev

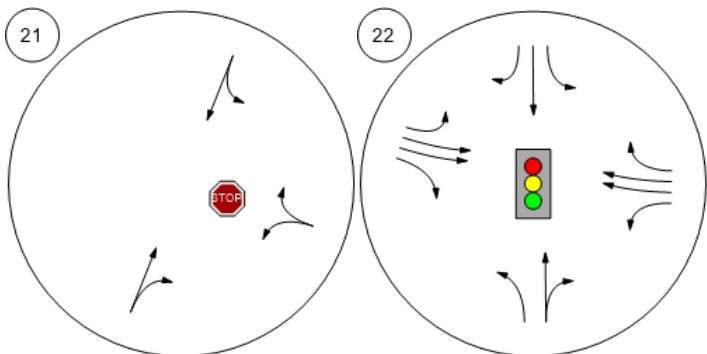

Traffic Volume - Base Volume

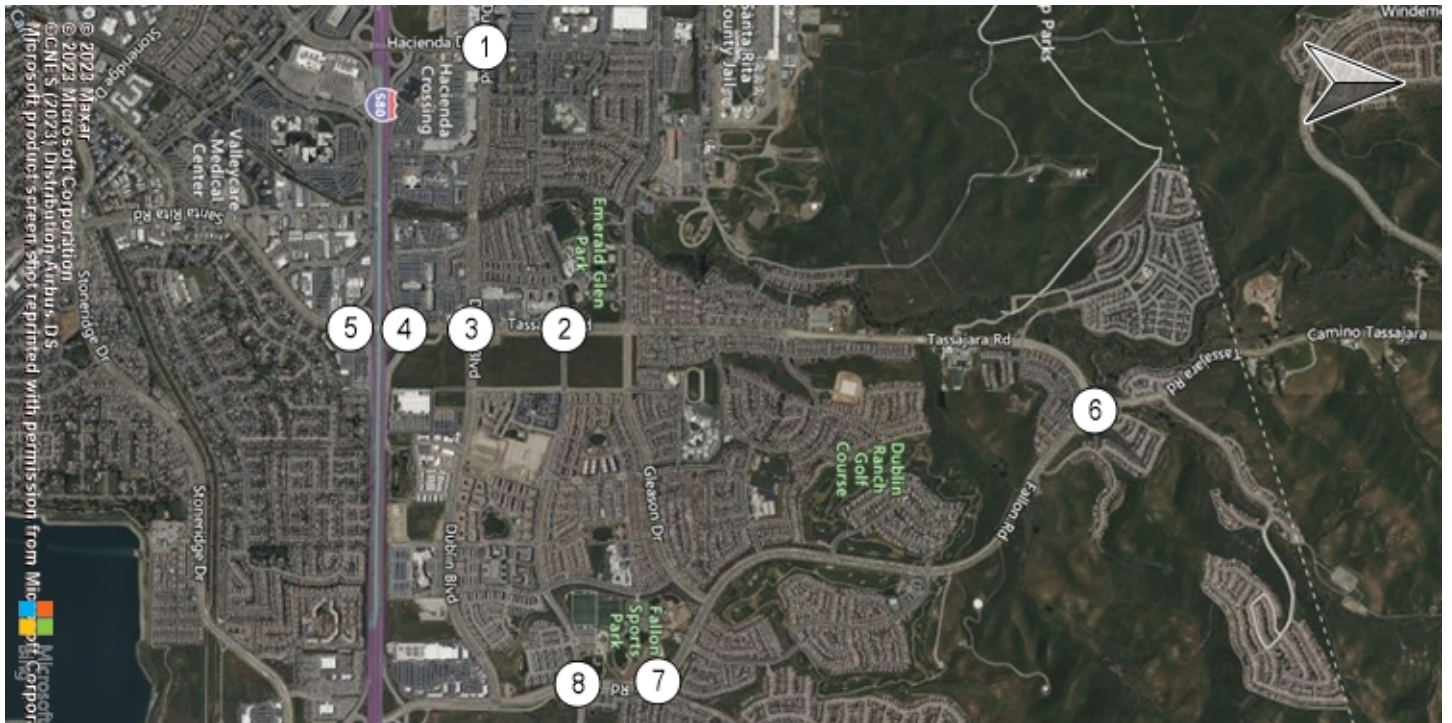

Hacienda Drive & Dublin Boul Tassajara Road & Central Pa Tassajara Road & Dublin Bou Tassajara Road & I-580 WB

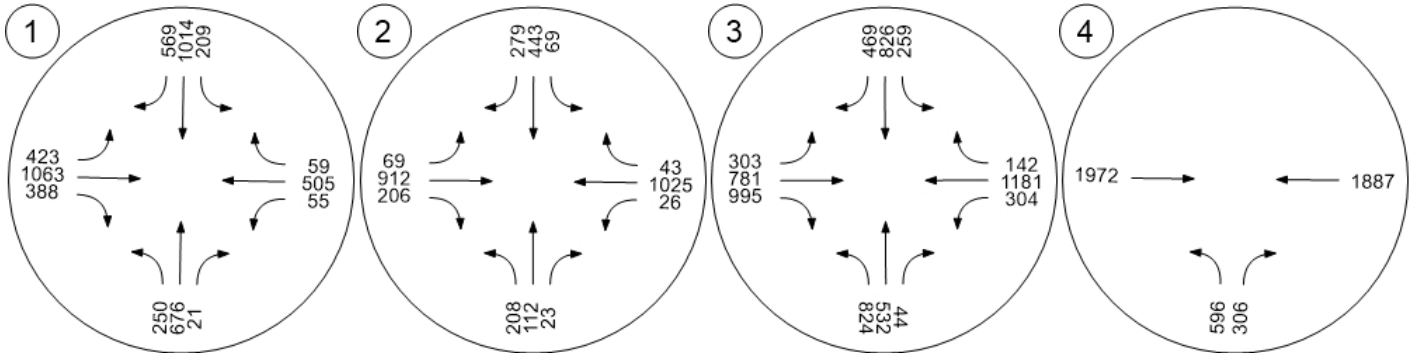

Santa Rita Rd & I-580 EB Ra Tassajara Road & Fallon Roa Fallon Road & Positano Park Fallon Road & Central Parkw

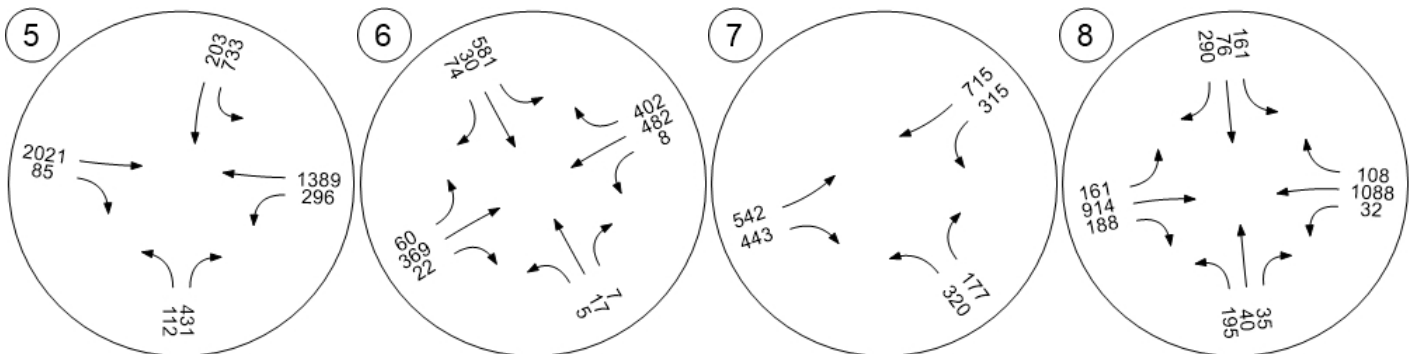



Traffic Volume - Base Volume

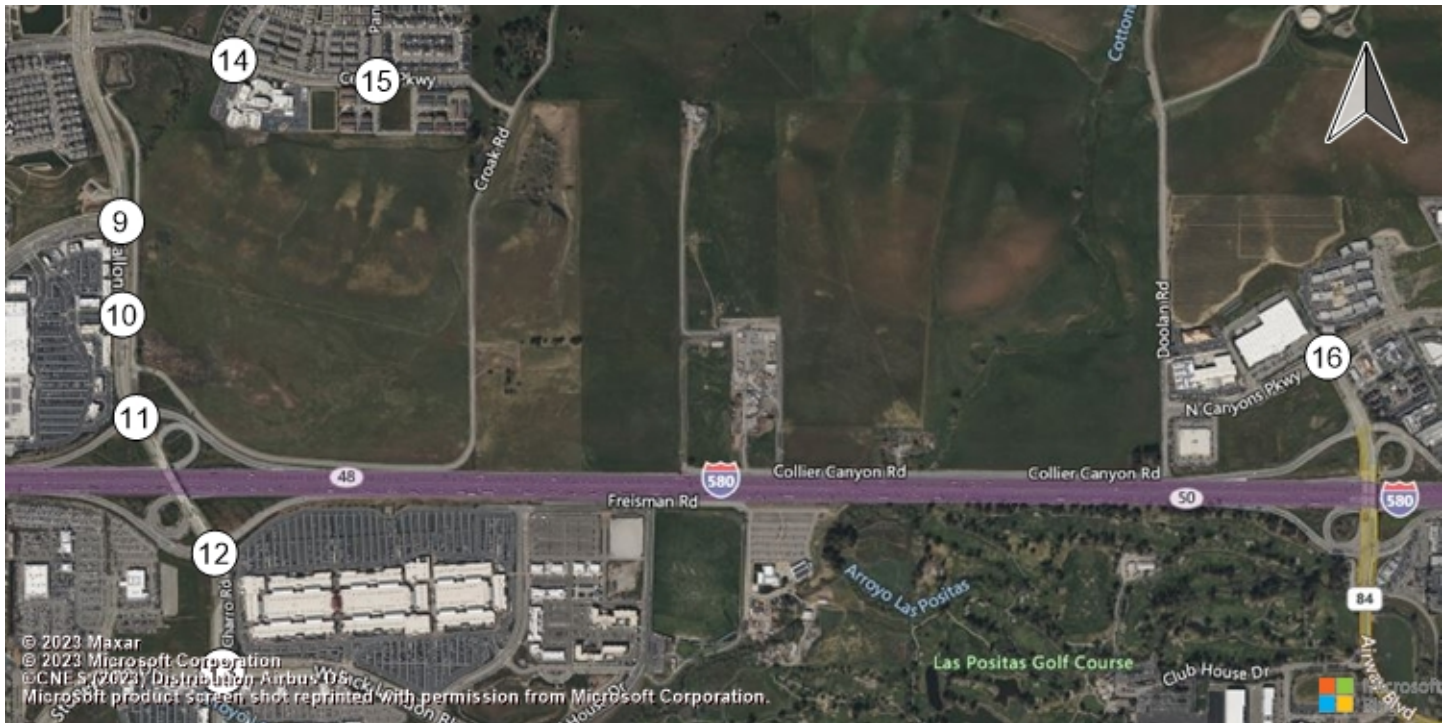

Fallon Road & Dublin Boulevard Fallon Road & Fallon Gateway Fallon Road & I-580 WB Ram El Charro Road & I-580 EB R

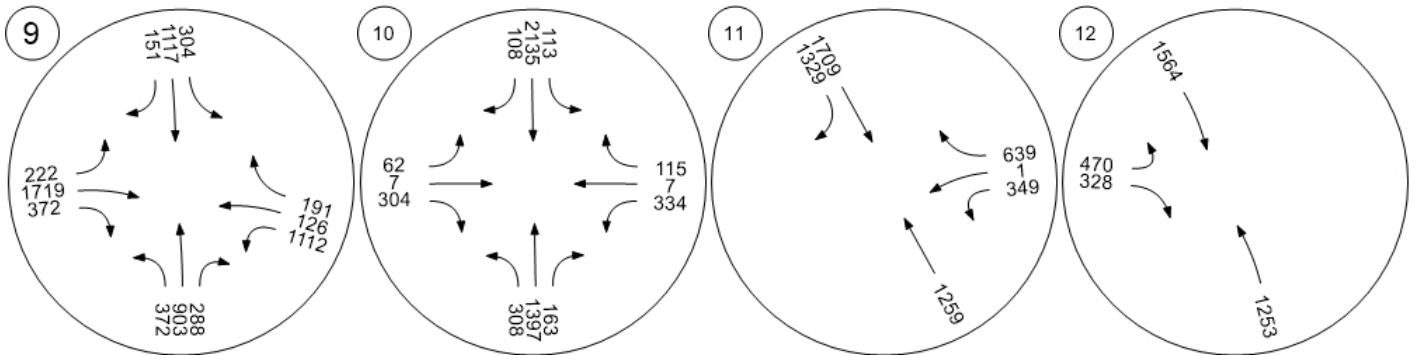

El Charro Road & Jack Lond Central Parkway & Sunset Vi Central Parkway & Panorama Airway Boulevard & N. Canyon Blvd

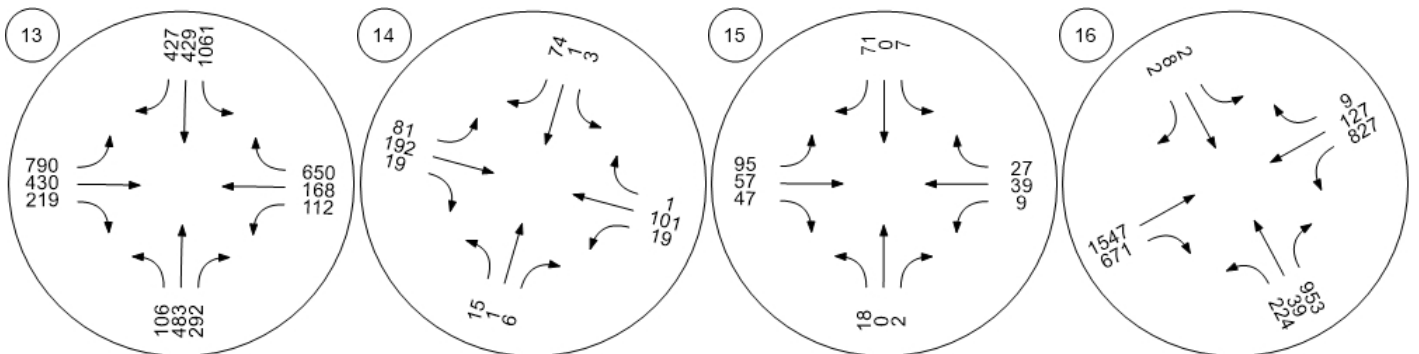

Traffic Volume - Base Volume

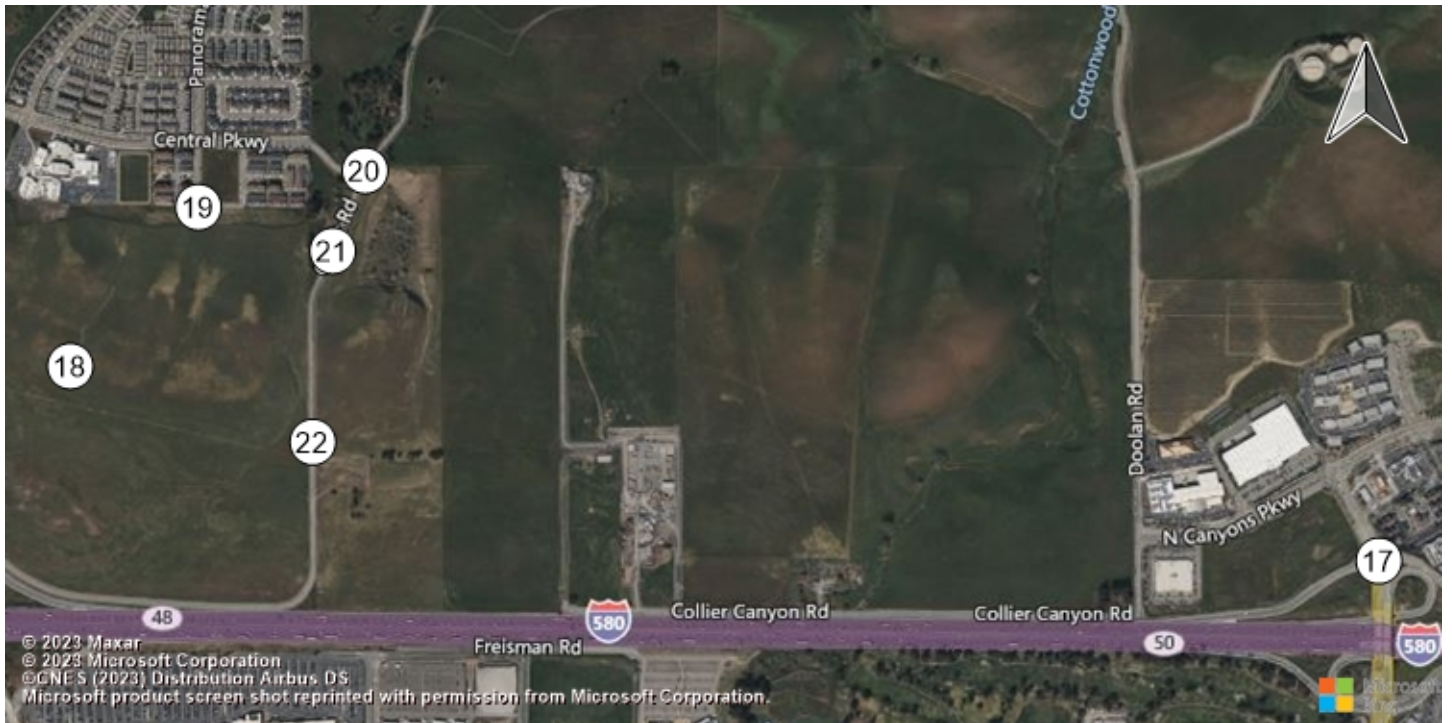

Airway Boulevard & I-580 WB Dublin Boulevard & Commercial Pandora Way & Residential P Croak Road & Central Parkw

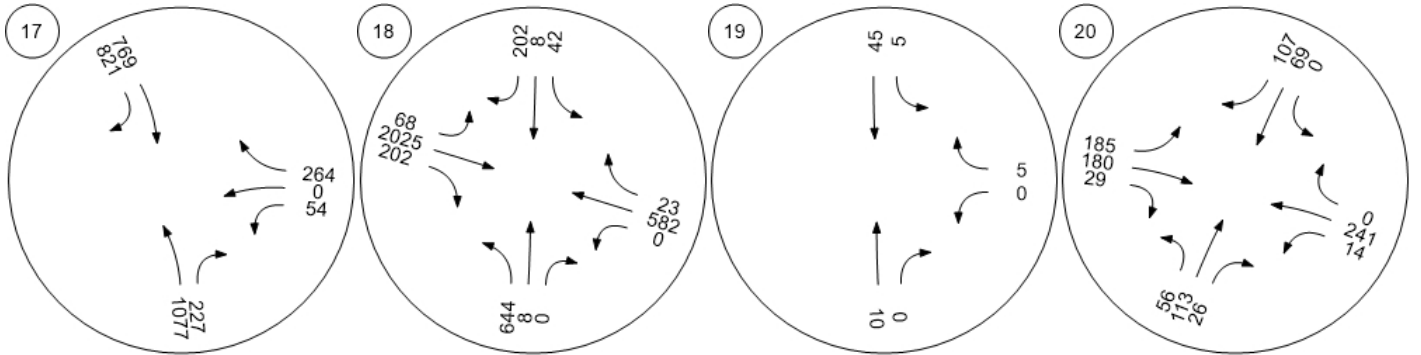

Croak Road & Project Access Croak Road & Dublin Boulev

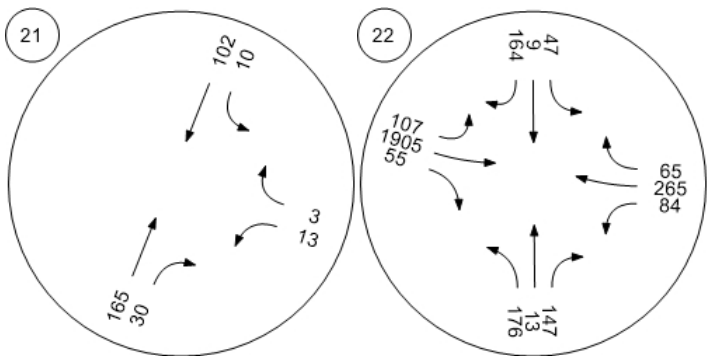





## Appendix K: Cumulative Plus Project Operational Outputs

Vistro File: H:\...\PacVest\_20240329.vistro

Scenario 11 Cumulative AM Plus Project

Report File: H:\...\CumulativeAM\_PP\_LOS.pdf

3/29/2024

**Intersection Analysis Summary**

ID	Intersection Name	Control Type	Method	Worst Mvmt	V/C	Delay (s/veh)	LOS
1	Hacienda Drive & Dublin Boulevard	Signalized	HCM 7th Edition	WB Left	0.558	56.7	E
2	Tassajara Road & Central Parkway	Signalized	HCM 7th Edition	SB Left	0.644	29.1	C
3	Tassajara Road & Dublin Boulevard	Signalized	HCM 7th Edition	WB Right	1.201	166.8	F
4	Tassajara Road & I-580 WB Ramps	Signalized	HCM 7th Edition	WB Left	0.782	15.9	B
5	Santa Rita Rd & I-580 EB Ramps/Pimlico Dr	Signalized	HCM 7th Edition	SB Left	0.812	36.3	D
6	Tassajara Road & Fallon Road	Signalized	HCM 7th Edition	SB Left	0.702	26.4	C
7	Fallon Road & Positano Parkway	Signalized	HCM 7th Edition	WB Right	1.049	75.0	E
8	Fallon Road & Central Parkway	Signalized	HCM 7th Edition	SB Thru	0.658	42.9	D
9	Fallon Road & Dublin Boulevard	Signalized	HCM 7th Edition	WB Left	0.798	45.0	D
10	Fallon Road & Fallon Gateway	Signalized	HCM 7th Edition	SB Left	0.429	15.8	B
11	Fallon Road & I-580 WB Ramps	Signalized	HCM 7th Edition	NB Thru	1.061	179.5	F
12	El Charro Road & I-580 EB Ramps	Signalized	HCM 7th Edition	EB Left	0.843	10.1	B
13	El Charro Road & Jack London Boulevard	Signalized	HCM 7th Edition	NB Right	0.870	76.7	E
14	Central Parkway & Sunset View Drive	Signalized	HCM 7th Edition	EB Right	0.791	34.4	C
15	Central Parkway & Panorama Drive/Pino Grande Road	All-way stop	HCM 7th Edition	EB Left	0.377	12.0	B
16	Airway Boulevard & N. Canyons Parkway	Signalized	HCM 7th Edition	SB Thru	0.728	25.1	C
17	Airway Boulevard & I-580 WB Ramps	Signalized	HCM 7th Edition	WB Right	0.482	42.7	D
	Dublin Boulevard &		HCM 7th				



Version 2024 (SP 0-1)

18	Dublin Boulevard & Commercial Access Driveway	Signalized	HCM 7th Edition	EB Left	0.647	33.8	C
19	Pandora Way & Residential Project Access Driveway (Parcel 7)	All-way stop	HCM 7th Edition	SB Left	0.060	7.1	A
20	Croak Road & Central Parkway	All-way stop	HCM 7th Edition	EB Thru	0.514	11.8	B
21	Croak Road & Project Access (Parcel 8)	Two-way stop	HCM 7th Edition	WB Left	0.057	10.4	B
22	Croak Road & Dublin Boulevard	Signalized	HCM 7th Edition	SB Left	0.649	36.0	D

V/C, Delay, LOS: For two-way stop, these values are taken from the movement with the worst (highest) delay value. For all other control types, they are taken for the whole intersection.

**Intersection Level Of Service Report**  
**Intersection 1: Hacienda Drive & Dublin Boulevard**

Control Type:	Signalized	Delay (sec / veh):	56.7
Analysis Method:	HCM 7th Edition	Level Of Service:	E
Analysis Period:	15 minutes	Volume to Capacity (v/c):	0.558

**Intersection Setup**

Name	Hacienda Drive			Hacienda Drive			Dublin Boulevard			Dublin Boulevard		
Approach	Northbound			Southbound			Eastbound			Westbound		
Lane Configuration	[Diagram]			[Diagram]			[Diagram]			[Diagram]		
Turning Movement	Left	Thru	Right	Left	Thru	Right	Left	Thru	Right	Left	Thru	Right
Lane Width [ft]	12.00	12.00	12.00	12.00	12.00	12.00	12.00	12.00	12.00	12.00	12.00	12.00
No. of Lanes in Entry Pocket	2	0	2	2	0	1	2	0	2	2	0	0
Entry Pocket Length [ft]	250.00	100.00	380.00	300.00	100.00	220.00	300.00	100.00	250.00	275.00	100.00	100.00
No. of Lanes in Exit Pocket	0	0	0	0	0	0	0	0	0	0	0	1
Exit Pocket Length [ft]	0.00	0.00	0.00	0.00	0.00	0.00	0.00	0.00	0.00	0.00	0.00	1000.00
Speed [mph]	35.00			35.00			40.00			40.00		
Grade [%]	0.00			0.00			0.00			0.00		
Curb Present	Yes			Yes			Yes			Yes		
Crosswalk	Yes			Yes			Yes			Yes		



**Volumes**

Name	Hacienda Drive			Hacienda Drive			Dublin Boulevard			Dublin Boulevard		
Base Volume Input [veh/h]	336	611	164	11	401	68	80	548	223	484	1518	41
Base Volume Adjustment Factor	1.0000	1.0000	1.0000	1.0000	1.0000	1.0000	1.0000	1.0000	1.0000	1.0000	1.0000	1.0000
Heavy Vehicles Percentage [%]	3.40	1.10	1.90	0.00	1.50	4.50	5.20	1.70	8.60	0.50	2.30	4.80
Proportion of CAVs [%]	0.00											
Growth Factor	1.0000	1.0000	1.0000	1.0000	1.0000	1.0000	1.0000	1.0000	1.0000	1.0000	1.0000	1.0000
In-Process Volume [veh/h]	0	0	0	0	0	0	0	0	0	0	0	0
Site-Generated Trips [veh/h]	0	0	0	0	0	0	0	0	0	0	0	0
Diverted Trips [veh/h]	0	0	0	0	0	0	0	0	0	0	0	0
Pass-by Trips [veh/h]	0	0	0	0	0	0	0	0	0	0	0	0
Existing Site Adjustment Volume [veh/h]	0	0	0	0	0	0	0	0	0	0	0	0
Other Volume [veh/h]	0	0	0	0	0	0	0	0	0	0	0	0
Right Turn on Red Volume [veh/h]	0	0	0	0	0	0	0	0	0	0	0	0
Total Hourly Volume [veh/h]	336	611	164	11	401	68	80	548	223	484	1518	41
Peak Hour Factor	0.9500	0.9500	0.9500	0.9500	0.9500	0.9500	0.9500	0.9500	0.9500	0.9500	0.9500	0.9500
Other Adjustment Factor	1.0000	1.0000	1.0000	1.0000	1.0000	1.0000	1.0000	1.0000	1.0000	1.0000	1.0000	1.0000
Total 15-Minute Volume [veh/h]	88	161	43	3	106	18	21	144	59	127	399	11
Total Analysis Volume [veh/h]	354	643	173	12	422	72	84	577	235	509	1598	43
Presence of On-Street Parking	No		No	No		No	No		No	No		No
On-Street Parking Maneuver Rate [/h]	0	0	0	0	0	0	0	0	0	0	0	0
Local Bus Stopping Rate [/h]	0	0	0	0	0	0	0	0	0	0	0	0
v_do, Outbound Pedestrian Volume crossing	1			3			0			2		
v_di, Inbound Pedestrian Volume crossing m	0			2			1			3		
v_co, Outbound Pedestrian Volume crossing	0			2			3			1		
v_ci, Inbound Pedestrian Volume crossing mi	1			3			2			0		
v_ab, Corner Pedestrian Volume [ped/h]	0			0			0			0		
Bicycle Volume [bicycles/h]	0			0			0			1		



**Intersection Settings**

Located in CBD	No
Signal Coordination Group	-
Cycle Length [s]	150
Active Pattern	Pattern 1
Coordination Type	Time of Day Pattern Coordinated
Actuation Type	Fully actuated
Offset [s]	57.0
Offset Reference	Lead Green - Beginning of First Green
Permissive Mode	SingleBand
Lost time [s]	12.00

**Phasing & Timing (Basic)**

Control Type	Protecte	Permiss	Permiss	Protecte	Permiss	Permiss	Protecte	Permiss	Permiss	Protecte	Permiss	Permiss
Signal Group	3	8	0	7	4	0	5	2	0	1	6	0
Auxiliary Signal Groups												
Maximum Green [s]	20	50	0	20	50	0	20	60	0	20	60	0
Amber [s]	3.5	4.5	0.0	3.5	4.1	0.0	3.5	4.5	0.0	3.5	4.5	0.0
All red [s]	1.5	1.5	0.0	1.0	1.5	0.0	1.0	1.5	0.0	1.0	1.5	0.0
Walk [s]	0	4	0	0	4	0	0	4	0	0	4	0
Pedestrian Clearance [s]	0	32	0	0	40	0	0	43	0	0	35	0
Delayed Vehicle Green [s]	0.0	0.0	0.0	0.0	0.0	0.0	0.0	0.0	0.0	0.0	0.0	0.0
Rest In Walk		No			No			No			No	
I1, Start-Up Lost Time [s]	2.0	2.0	0.0	2.0	2.0	0.0	2.0	2.0	0.0	2.0	2.0	0.0
I2, Clearance Lost Time [s]	2.0	2.0	0.0	2.0	2.0	0.0	2.0	2.0	0.0	2.0	2.0	0.0
Detector Location [ft]	0.0	0.0	0.0	0.0	0.0	0.0	0.0	0.0	0.0	0.0	0.0	0.0
Detector Length [ft]	20.0	20.0	0.0	20.0	20.0	0.0	20.0	20.0	0.0	20.0	20.0	0.0
I, Upstream Filtering Factor	1.00	1.00	1.00	1.00	1.00	1.00	1.00	1.00	1.00	1.00	1.00	1.00

**Phasing & Timing: Pattern 1**

Split [s]	18	55	0	14	51	0	15	61	0	20	66	0
Lead / Lag	Lead	-	-	Lead	-	-	Lead	-	-	Lead	-	-
Minimum Green [s]	4	10	0	4	10	0	4	10	0	8	10	0
Vehicle Extension [s]	3.0	3.5	0.0	3.0	3.5	0.0	3.0	3.5	0.0	3.0	3.5	0.0
Minimum Recall	No	No		No	No		No	Yes		No	Yes	
Maximum Recall	No	No		No	No		No	No		No	No	
Pedestrian Recall	No	No		No	No		No	No		No	No	

**Exclusive Pedestrian Phase**

Pedestrian Signal Group	0
Pedestrian Walk [s]	0
Pedestrian Clearance [s]	0



**Lane Group Calculations**

Lane Group	L	C	R	L	C	R	L	C	R	L	C	C
C, Cycle Length [s]	150	150	150	150	150	150	150	150	150	150	150	150
L, Total Lost Time per Cycle [s]	4.00	4.00	4.00	4.00	4.00	4.00	4.00	4.00	4.00	4.00	4.00	4.00
l1_p, Permitted Start-Up Lost Time [s]	0.00	0.00	0.00	0.00	0.00	0.00	0.00	0.00	0.00	0.00	0.00	0.00
l2, Clearance Lost Time [s]	2.00	2.00	2.00	2.00	2.00	2.00	2.00	2.00	2.00	2.00	2.00	2.00
g_i, Effective Green Time [s]	13	33	33	2	22	22	6	83	83	16	93	93
g / C, Green / Cycle	0.09	0.22	0.22	0.01	0.15	0.15	0.04	0.55	0.55	0.11	0.62	0.62
(v / s)_i Volume / Saturation Flow Rate	0.07	0.18	0.06	0.00	0.08	0.05	0.02	0.11	0.09	0.15	0.30	0.31
s, saturation flow rate [veh/h]	5130	3586	2812	3514	5114	1542	3370	5106	2663	3500	3552	1838
c, Capacity [veh/h]	455	796	624	50	755	227	138	2810	1466	374	2189	1133
d1, Uniform Delay [s]	66.94	55.35	48.40	73.16	59.44	57.17	70.79	17.10	16.64	67.03	15.88	15.91
k, delay calibration	0.11	0.13	0.13	0.11	0.13	0.13	0.11	0.50	0.50	0.11	0.50	0.50
l, Upstream Filtering Factor	1.00	1.00	1.00	1.00	1.00	1.00	1.00	1.00	1.00	1.00	1.00	1.00
d2, Incremental Delay [s]	2.91	2.41	0.29	2.40	0.79	0.95	4.30	0.17	0.23	166.98	0.80	1.55
d3, Initial Queue Delay [s]	0.00	0.00	0.00	0.00	0.00	0.00	0.00	0.00	0.00	0.00	0.00	0.00
Rp, platoon ratio	1.00	1.00	1.00	1.00	1.00	1.00	1.00	1.00	1.00	1.00	1.00	1.00
PF, progression factor	1.00	1.00	1.00	1.00	1.00	1.00	1.00	1.00	1.00	1.00	1.00	1.00

**Lane Group Results**

X, volume / capacity	0.78	0.81	0.28	0.24	0.56	0.32	0.61	0.21	0.16	1.36	0.49	0.50
d, Delay for Lane Group [s/veh]	69.84	57.77	48.69	75.56	60.22	58.13	75.09	17.27	16.87	234.01	16.68	17.46
Lane Group LOS	E	E	D	E	E	E	E	B	B	F	B	B
Critical Lane Group	No	Yes	No	Yes	No	No	Yes	No	No	No	No	Yes
50th-Percentile Queue Length [veh/ln]	4.54	11.75	2.73	0.25	5.03	2.51	1.66	3.38	2.03	15.75	10.04	10.69
50th-Percentile Queue Length [ft/ln]	113.57	293.86	68.19	6.14	125.68	62.71	41.52	84.47	50.75	393.76	251.05	267.34
95th-Percentile Queue Length [veh/ln]	8.04	17.38	4.91	0.44	8.70	4.52	2.99	6.08	3.65	24.88	15.24	16.06
95th-Percentile Queue Length [ft/ln]	200.96	434.43	122.74	11.05	217.60	112.88	74.73	152.04	91.35	622.04	380.98	401.41



**Movement, Approach, & Intersection Results**

d_M, Delay for Movement [s/veh]	69.84	57.77	48.69	75.56	60.22	58.13	75.09	17.27	16.87	234.01	16.93	17.46
Movement LOS	E	E	D	E	E	E	E	B	B	F	B	B
d_A, Approach Delay [s/veh]	60.08			60.29			22.58			68.33		
Approach LOS	E			E			C			E		
d_I, Intersection Delay [s/veh]	56.75											
Intersection LOS	E											
Intersection V/C	0.558											

**Emissions**

Vehicle Miles Traveled [mph]	35.92	65.25	17.56	1.40	49.12	8.38	9.60	65.95	26.86	447.57	949.47	493.49
Stops [stops/h]	326.99	564.06	130.89	11.78	361.85	60.18	79.69	243.19	97.42	755.81	481.88	256.58
Fuel consumption [US gal/h]	8.86	14.29	3.37	0.33	9.76	1.62	2.41	6.78	2.73	47.69	42.41	22.19
CO [g/h]	619.25	998.67	235.39	22.81	682.54	113.49	168.47	473.84	190.54	3333.58	2964.41	1551.21
NOx [g/h]	120.48	194.30	45.80	4.44	132.80	22.08	32.78	92.19	37.07	648.59	576.77	301.81
VOC [g/h]	143.52	231.45	54.55	5.29	158.19	26.30	39.04	109.82	44.16	772.59	687.03	359.51

**Other Modes**

g_Walk,mi, Effective Walk Time [s]	8.0			8.0			8.0			8.0		
M_corner, Corner Circulation Area [ft <sup>2</sup> /ped]	0.00			0.00			0.00			0.00		
M_CW, Crosswalk Circulation Area [ft <sup>2</sup> /ped]	3016.60			892.38			868.99			3130.08		
d_p, Pedestrian Delay [s]	67.23			67.23			67.23			67.23		
I_p,int, Pedestrian LOS Score for Intersectio	3.258			2.933			3.372			3.225		
Crosswalk LOS	C			C			C			C		
s_b, Saturation Flow Rate of the bicycle lane	2000			2000			2000			2000		
c_b, Capacity of the bicycle lane [bicycles/h]	653			605			733			800		
d_b, Bicycle Delay [s]	34.02			36.49			30.10			27.03		
I_b,int, Bicycle LOS Score for Intersection	2.525			1.838			2.052			2.742		
Bicycle LOS	B			A			B			B		

**Sequence**

Ring 1	1	2	3	4	-	-	-	-	-	-	-	-	-	-	-
Ring 2	5	6	7	8	-	-	-	-	-	-	-	-	-	-	-
Ring 3	-	-	-	-	-	-	-	-	-	-	-	-	-	-	-
Ring 4	-	-	-	-	-	-	-	-	-	-	-	-	-	-	-

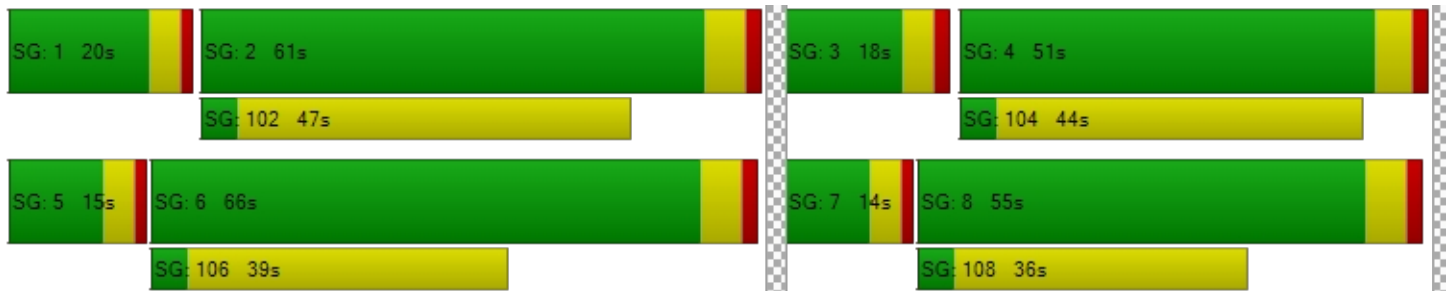



**Intersection Level Of Service Report**  
**Intersection 2: Tassajara Road & Central Parkway**

Control Type:	Signalized	Delay (sec / veh):	29.1
Analysis Method:	HCM 7th Edition	Level Of Service:	C
Analysis Period:	15 minutes	Volume to Capacity (v/c):	0.644

**Intersection Setup**

Name	Tassajara Road			Tassajara Road			Central Parkway			Central Parkway		
Approach	Northbound			Southbound			Eastbound			Westbound		
Lane Configuration	⇐   ⇐			⇐   ⇐			⇐  ⇐			⇐  ⇐		
Turning Movement	Left	Thru	Right	Left	Thru	Right	Left	Thru	Right	Left	Thru	Right
Lane Width [ft]	12.00	12.00	12.00	12.00	12.00	12.00	12.00	12.00	12.00	12.00	12.00	12.00
No. of Lanes in Entry Pocket	1	0	1	1	0	1	1	0	1	2	0	0
Entry Pocket Length [ft]	325.00	100.00	325.00	300.00	100.00	215.00	225.00	100.00	225.00	300.00	100.00	100.00
No. of Lanes in Exit Pocket	0	0	0	0	0	0	0	0	0	0	0	0
Exit Pocket Length [ft]	0.00	0.00	0.00	0.00	0.00	0.00	0.00	0.00	0.00	0.00	0.00	0.00
Speed [mph]	40.00			40.00			35.00			35.00		
Grade [%]	0.00			0.00			0.00			0.00		
Curb Present	Yes			Yes			Yes			Yes		
Crosswalk	Yes			Yes			Yes			Yes		



**Volumes**

Name	Tassajara Road			Tassajara Road			Central Parkway			Central Parkway		
Base Volume Input [veh/h]	32	668	100	17	1367	107	91	117	60	215	136	19
Base Volume Adjustment Factor	1.0000	1.0000	1.0000	1.0000	1.0000	1.0000	1.0000	1.0000	1.0000	1.0000	1.0000	1.0000
Heavy Vehicles Percentage [%]	0.00	2.00	8.50	0.00	0.70	2.10	1.10	0.00	1.70	0.90	0.00	0.00
Proportion of CAVs [%]	0.00											
Growth Factor	1.0000	1.0000	1.0000	1.0000	1.0000	1.0000	1.0000	1.0000	1.0000	1.0000	1.0000	1.0000
In-Process Volume [veh/h]	0	0	0	0	0	0	0	0	0	0	0	0
Site-Generated Trips [veh/h]	0	0	0	0	0	0	0	0	0	0	0	0
Diverted Trips [veh/h]	0	0	0	0	0	0	0	0	0	0	0	0
Pass-by Trips [veh/h]	0	0	0	0	0	0	0	0	0	0	0	0
Existing Site Adjustment Volume [veh/h]	0	0	0	0	0	0	0	0	0	0	0	0
Other Volume [veh/h]	0	0	0	0	0	0	0	0	0	0	0	0
Right Turn on Red Volume [veh/h]	0	0	0	0	0	0	0	0	0	0	0	0
Total Hourly Volume [veh/h]	32	668	100	17	1367	107	91	117	60	215	136	19
Peak Hour Factor	0.9100	0.9100	0.9100	0.9100	0.9100	0.9100	0.9100	0.9100	0.9100	0.9100	0.9100	0.9100
Other Adjustment Factor	1.0000	1.0000	1.0000	1.0000	1.0000	1.0000	1.0000	1.0000	1.0000	1.0000	1.0000	1.0000
Total 15-Minute Volume [veh/h]	9	184	27	5	376	29	25	32	16	59	37	5
Total Analysis Volume [veh/h]	35	734	110	19	1502	118	100	129	66	236	149	21
Presence of On-Street Parking	No		No	No		No	No		No	No		No
On-Street Parking Maneuver Rate [/h]	0	0	0	0	0	0	0	0	0	0	0	0
Local Bus Stopping Rate [/h]	0	0	0	0	0	0	0	0	0	0	0	0
v_do, Outbound Pedestrian Volume crossing	2			2			1			2		
v_di, Inbound Pedestrian Volume crossing m	1			2			2			2		
v_co, Outbound Pedestrian Volume crossing	1			6			7			2		
v_ci, Inbound Pedestrian Volume crossing mi	2			7			6			1		
v_ab, Corner Pedestrian Volume [ped/h]	0			0			0			0		
Bicycle Volume [bicycles/h]	0			0			0			12		



**Intersection Settings**

Located in CBD	No
Signal Coordination Group	-
Cycle Length [s]	130
Active Pattern	Pattern 1
Coordination Type	Time of Day Pattern Coordinated
Actuation Type	Fully actuated
Offset [s]	20.0
Offset Reference	Lead Green - Beginning of First Green
Permissive Mode	SingleBand
Lost time [s]	12.00

**Phasing & Timing (Basic)**

Control Type	Protecte	Permiss	Permiss	Protecte	Permiss	Permiss	Protecte	Permiss	Permiss	Protecte	Permiss	Permiss
Signal Group	3	8	0	7	4	0	5	2	0	1	6	0
Auxiliary Signal Groups												
Maximum Green [s]	20	40	0	20	40	0	20	20	0	20	20	0
Amber [s]	3.5	4.3	0.0	3.5	4.3	0.0	3.5	4.1	0.0	3.5	4.1	0.0
All red [s]	1.0	1.0	0.0	1.0	1.0	0.0	1.0	1.0	0.0	1.0	1.0	0.0
Walk [s]	0	4	0	0	4	0	0	4	0	0	4	0
Pedestrian Clearance [s]	0	20	0	0	24	0	0	36	0	0	30	0
Delayed Vehicle Green [s]	0.0	0.0	0.0	0.0	0.0	0.0	0.0	0.0	0.0	0.0	0.0	0.0
Rest In Walk		No			No			No			No	
I1, Start-Up Lost Time [s]	2.0	2.0	0.0	2.0	2.0	0.0	2.0	2.0	0.0	2.0	2.0	0.0
I2, Clearance Lost Time [s]	2.5	3.3	0.0	2.5	3.3	0.0	2.5	3.1	0.0	2.5	3.1	0.0
Detector Location [ft]	0.0	0.0	0.0	0.0	0.0	0.0	0.0	0.0	0.0	0.0	0.0	0.0
Detector Length [ft]	20.0	20.0	0.0	20.0	20.0	0.0	20.0	20.0	0.0	20.0	20.0	0.0
I, Upstream Filtering Factor	1.00	1.00	1.00	1.00	1.00	1.00	1.00	1.00	1.00	1.00	1.00	1.00

**Phasing & Timing: Pattern 1**

Split [s]	18	48	0	18	48	0	23	45	0	19	41	0
Lead / Lag	Lead	-	-	Lead	-	-	Lead	-	-	Lead	-	-
Minimum Green [s]	13	12	0	13	12	0	13	13	0	14	13	0
Vehicle Extension [s]	2.5	4.0	0.0	2.5	4.0	0.0	2.5	2.5	0.0	2.5	2.5	0.0
Minimum Recall	No	Yes		No	Yes		No	No		No	No	
Maximum Recall	No	No		No	No		No	No		No	No	
Pedestrian Recall	No	No		No	No		No	No		No	No	

**Exclusive Pedestrian Phase**

Pedestrian Signal Group	0
Pedestrian Walk [s]	0
Pedestrian Clearance [s]	0



**Lane Group Calculations**

Lane Group	L	C	R	L	C	R	L	C	R	L	C
C, Cycle Length [s]	130	130	130	130	130	130	130	130	130	130	130
L, Total Lost Time per Cycle [s]	4.50	5.30	5.30	4.50	5.30	5.30	4.50	5.10	5.10	4.50	5.10
l1_p, Permitted Start-Up Lost Time [s]	0.00	0.00	0.00	0.00	0.00	0.00	0.00	0.00	0.00	0.00	0.00
l2, Clearance Lost Time [s]	2.50	3.30	3.30	2.50	3.30	3.30	2.50	3.10	3.10	2.50	3.10
g_i, Effective Green Time [s]	9	76	76	6	73	73	13	14	14	14	16
g / C, Green / Cycle	0.07	0.58	0.58	0.05	0.56	0.56	0.10	0.11	0.11	0.11	0.12
(v / s)_i Volume / Saturation Flow Rate	0.02	0.21	0.07	0.01	0.42	0.08	0.06	0.07	0.04	0.07	0.09
s, saturation flow rate [veh/h]	1810	3560	1503	1810	3598	1570	1794	1900	1580	3489	1848
c, Capacity [veh/h]	130	2071	874	90	2013	878	175	211	176	376	225
d1, Uniform Delay [s]	57.06	14.33	12.27	59.27	21.64	13.62	56.05	55.06	53.54	55.47	55.22
k, delay calibration	0.08	0.50	0.50	0.08	0.50	0.50	0.08	0.08	0.08	0.08	0.08
l, Upstream Filtering Factor	1.00	1.00	1.00	1.00	1.00	1.00	1.00	1.00	1.00	1.00	1.00
d2, Incremental Delay [s]	0.81	0.48	0.30	0.85	2.57	0.32	2.18	2.11	0.98	1.28	3.86
d3, Initial Queue Delay [s]	0.00	0.00	0.00	0.00	0.00	0.00	0.00	0.00	0.00	0.00	0.00
Rp, platoon ratio	1.00	1.00	1.00	1.00	1.00	1.00	1.00	1.00	1.00	1.00	1.00
PF, progression factor	1.00	1.00	1.00	1.00	1.00	1.00	1.00	1.00	1.00	1.00	1.00

**Lane Group Results**

X, volume / capacity	0.27	0.35	0.13	0.21	0.75	0.13	0.57	0.61	0.38	0.63	0.76
d, Delay for Lane Group [s/veh]	57.87	14.81	12.57	60.11	24.21	13.93	58.22	57.18	54.53	56.75	59.07
Lane Group LOS	E	B	B	E	C	B	E	E	D	E	E
Critical Lane Group	Yes	No	No	No	Yes	No	Yes	No	No	No	Yes
50th-Percentile Queue Length [veh/ln]	1.11	5.57	1.47	0.62	16.90	1.68	3.23	4.13	2.04	3.75	5.60
50th-Percentile Queue Length [ft/ln]	27.66	139.28	36.67	15.40	422.51	41.94	80.69	103.37	51.08	93.75	139.91
95th-Percentile Queue Length [veh/ln]	1.99	9.44	2.64	1.11	23.64	3.02	5.81	7.44	3.68	6.75	9.48
95th-Percentile Queue Length [ft/ln]	49.78	236.06	66.01	27.72	591.06	75.48	145.24	186.07	91.95	168.76	236.91



**Movement, Approach, & Intersection Results**

d_M, Delay for Movement [s/veh]	57.87	14.81	12.57	60.11	24.21	13.93	58.22	57.18	54.53	56.75	59.07	59.07
Movement LOS	E	B	B	E	C	B	E	E	D	E	E	E
d_A, Approach Delay [s/veh]	16.24			23.89			56.94			57.72		
Approach LOS	B			C			E			E		
d_I, Intersection Delay [s/veh]	29.09											
Intersection LOS	C											
Intersection V/C	0.644											

**Emissions**

Vehicle Miles Traveled [mph]	10.09	211.68	31.72	3.61	285.72	22.45	13.16	16.98	8.69	32.00	23.05
Stops [stops/h]	30.64	308.62	40.63	17.06	936.17	46.46	89.39	114.52	56.60	207.73	155.01
Fuel consumption [US gal/h]	1.07	12.83	1.82	0.53	26.83	1.60	2.36	3.01	1.49	5.51	4.09
CO [g/h]	75.12	896.52	126.99	37.01	1875.47	111.49	164.87	210.34	104.08	384.94	285.73
NOx [g/h]	14.62	174.43	24.71	7.20	364.90	21.69	32.08	40.92	20.25	74.90	55.59
VOC [g/h]	17.41	207.78	29.43	8.58	434.66	25.84	38.21	48.75	24.12	89.21	66.22

**Other Modes**

g_Walk,mi, Effective Walk Time [s]	8.0			8.0			8.0			8.0		
M_corner, Corner Circulation Area [ft <sup>2</sup> /ped]	0.00			0.00			0.00			0.00		
M_CW, Crosswalk Circulation Area [ft <sup>2</sup> /ped]	1666.25			1344.85			258.62			1082.04		
d_p, Pedestrian Delay [s]	57.24			57.24			57.24			57.24		
I_p,int, Pedestrian LOS Score for Intersectio	3.181			3.013			2.320			2.340		
Crosswalk LOS	C			C			B			B		
s_b, Saturation Flow Rate of the bicycle lane	2000			2000			2000			2000		
c_b, Capacity of the bicycle lane [bicycles/h]	657			657			614			552		
d_b, Bicycle Delay [s]	29.30			29.30			31.21			34.25		
I_b,int, Bicycle LOS Score for Intersection	2.285			2.912			2.046			2.230		
Bicycle LOS	B			C			B			B		

**Sequence**

Ring 1	1	2	3	4	-	-	-	-	-	-	-	-	-	-	-
Ring 2	5	6	7	8	-	-	-	-	-	-	-	-	-	-	-
Ring 3	-	-	-	-	-	-	-	-	-	-	-	-	-	-	-
Ring 4	-	-	-	-	-	-	-	-	-	-	-	-	-	-	-



**Intersection Level Of Service Report**  
**Intersection 3: Tassajara Road & Dublin Boulevard**

Control Type:	Signalized	Delay (sec / veh):	166.8
Analysis Method:	HCM 7th Edition	Level Of Service:	F
Analysis Period:	15 minutes	Volume to Capacity (v/c):	1.201

**Intersection Setup**

Name	Tassajara Road			Tassajara Road			Dublin Boulevard			Dublin Boulevard		
Approach	Northbound			Southbound			Eastbound			Westbound		
Lane Configuration	[Diagram]			[Diagram]			[Diagram]			[Diagram]		
Turning Movement	Left	Thru	Right	Left	Thru	Right	Left	Thru	Right	Left	Thru	Right
Lane Width [ft]	12.00	12.00	12.00	12.00	12.00	12.00	12.00	12.00	12.00	12.00	12.00	12.00
No. of Lanes in Entry Pocket	3	0	1	2	0	2	2	0	2	3	0	0
Entry Pocket Length [ft]	380.00	100.00	250.00	295.00	100.00	290.00	265.00	100.00	330.00	395.00	100.00	100.00
No. of Lanes in Exit Pocket	0	0	1	0	0	0	0	0	0	0	0	0
Exit Pocket Length [ft]	0.00	0.00	49.21	0.00	0.00	0.00	0.00	0.00	0.00	0.00	0.00	0.00
Speed [mph]	30.00			40.00			40.00			40.00		
Grade [%]	0.00			0.00			0.00			0.00		
Curb Present	Yes			Yes			Yes			Yes		
Crosswalk	Yes			Yes			Yes			Yes		



**Volumes**

Name	Tassajara Road			Tassajara Road			Dublin Boulevard			Dublin Boulevard		
Base Volume Input [veh/h]	386	631	737	94	1338	168	102	327	148	498	1570	146
Base Volume Adjustment Factor	1.0000	1.0000	1.0000	1.0000	1.0000	1.0000	1.0000	1.0000	1.0000	1.0000	1.0000	1.0000
Heavy Vehicles Percentage [%]	3.30	2.90	1.00	0.00	0.70	3.30	2.00	3.70	4.70	1.60	2.00	0.00
Proportion of CAVs [%]	0.00											
Growth Factor	1.0000	1.0000	1.0000	1.0000	1.0000	1.0000	1.0000	1.0000	1.0000	1.0000	1.0000	1.0000
In-Process Volume [veh/h]	0	0	0	0	0	0	0	0	0	0	0	0
Site-Generated Trips [veh/h]	0	0	0	0	0	0	0	0	0	0	0	0
Diverted Trips [veh/h]	0	0	0	0	0	0	0	0	0	0	0	0
Pass-by Trips [veh/h]	0	0	0	0	0	0	0	0	0	0	0	0
Existing Site Adjustment Volume [veh/h]	0	0	0	0	0	0	0	0	0	0	0	0
Other Volume [veh/h]	0	0	0	0	0	0	0	0	0	0	0	0
Right Turn on Red Volume [veh/h]	0	0	0	0	0	0	0	0	0	0	0	0
Total Hourly Volume [veh/h]	386	631	737	94	1338	168	102	327	148	498	1570	146
Peak Hour Factor	0.9200	0.9200	0.9200	0.9200	0.9200	0.9200	0.9200	0.9200	0.9200	0.9200	0.9200	0.9200
Other Adjustment Factor	1.0000	1.0000	1.0000	1.0000	1.0000	1.0000	1.0000	1.0000	1.0000	1.0000	1.0000	1.0000
Total 15-Minute Volume [veh/h]	105	171	200	26	364	46	28	89	40	135	427	40
Total Analysis Volume [veh/h]	420	686	801	102	1454	183	111	355	161	541	1707	159
Presence of On-Street Parking	No		No	No		No	No		No	No		No
On-Street Parking Maneuver Rate [/h]	0	0	0	0	0	0	0	0	0	0	0	0
Local Bus Stopping Rate [/h]	0	0	0	0	0	0	0	0	0	0	0	0
v_do, Outbound Pedestrian Volume crossing	1			2			2			1		
v_di, Inbound Pedestrian Volume crossing m	1			2			2			1		
v_co, Outbound Pedestrian Volume crossing	0			4			0			3		
v_ci, Inbound Pedestrian Volume crossing mi	0			3			0			4		
v_ab, Corner Pedestrian Volume [ped/h]	0			0			0			0		
Bicycle Volume [bicycles/h]	1			0			0			0		



**Intersection Settings**

Located in CBD	No
Signal Coordination Group	-
Cycle Length [s]	90
Active Pattern	Free Running (No Pattern)
Coordination Type	<i>Free Running</i>
Actuation Type	<i>Fully actuated</i>
Offset [s]	0.0
Offset Reference	Lead Green - Beginning of First Green
Permissive Mode	SingleBand
Lost time [s]	12.00

**Phasing & Timing (Basic)**

Control Type	Protecte	Permiss	Permiss	Protecte	Permiss	Permiss	Protecte	Permiss	Overlap	Protecte	Permiss	Permiss
Signal Group	3	8	0	7	4	0	5	2	2	1	6	0
Auxiliary Signal Groups									2,3			
Maximum Green [s]	20	35	0	20	35	0	20	35	35	20	35	0
Amber [s]	3.5	4.5	0.0	3.5	4.5	0.0	3.5	4.5	4.5	3.5	4.5	0.0
All red [s]	1.5	1.5	0.0	1.5	1.5	0.0	1.5	1.5	1.5	1.5	1.5	0.0
Walk [s]	0	4	0	0	4	0	0	0	0	0	4	0
Pedestrian Clearance [s]	0	29	0	0	42	0	0	0	0	0	42	0
Delayed Vehicle Green [s]	0.0	0.0	0.0	0.0	0.0	0.0	0.0	0.0	0.0	0.0	0.0	0.0
Rest In Walk		No			No			No			No	
I1, Start-Up Lost Time [s]	2.0	2.0	0.0	2.0	2.0	0.0	2.0	2.0	2.0	2.0	2.0	0.0
I2, Clearance Lost Time [s]	2.0	2.0	0.0	2.0	2.0	0.0	2.0	2.0	2.0	2.0	2.0	0.0
Detector Location [ft]	0.0	0.0	0.0	0.0	0.0	0.0	0.0	0.0	0.0	0.0	0.0	0.0
Detector Length [ft]	20.0	20.0	0.0	20.0	20.0	0.0	20.0	20.0	20.0	20.0	20.0	0.0
I, Upstream Filtering Factor	1.00	1.00	1.00	1.00	1.00	1.00	1.00	1.00	1.00	1.00	1.00	1.00

**Phasing & Timing: Free Running (No Pattern)**

Split [s]	0	0	0	0	0	0	0	0	0	0	0	0
Lead / Lag	Lead	-	-	Lead	-	-	Lead	-	-	Lead	-	-
Minimum Green [s]	16	15	0	15	15	0	16	16	16	16	15	0
Vehicle Extension [s]	2.0	4.0	0.0	2.0	4.0	0.0	2.0	3.0	3.0	2.0	3.0	0.0
Minimum Recall	No	Yes		No	Yes		No	No	No	No	No	
Maximum Recall	No	No		No	No		No	No	No	No	No	
Pedestrian Recall	No	No		No	No		No	No	No	No	No	

**Exclusive Pedestrian Phase**

Pedestrian Signal Group	0
Pedestrian Walk [s]	0
Pedestrian Clearance [s]	0





**Lane Group Calculations**

Lane Group	L	C	R	L	C	R	L	C	R	L	C	C
C, Cycle Length [s]	123	123	123	123	123	123	123	123	123	123	123	123
L, Total Lost Time per Cycle [s]	4.00	4.00	4.00	4.00	4.00	4.00	4.00	4.00	4.00	4.00	4.00	4.00
l1_p, Permitted Start-Up Lost Time [s]	0.00	0.00	0.00	0.00	0.00	0.00	0.00	0.00	0.00	0.00	0.00	0.00
l2, Clearance Lost Time [s]	2.00	2.00	2.00	2.00	2.00	2.00	2.00	2.00	0.00	2.00	2.00	2.00
g_i, Effective Green Time [s]	17	37	37	16	36	36	17	37	58	17	37	37
g / C, Green / Cycle	0.14	0.30	0.30	0.13	0.29	0.29	0.14	0.30	0.47	0.14	0.30	0.30
(v / s)_i Volume / Saturation Flow Rate	0.08	0.19	0.51	0.03	0.21	0.07	0.03	0.10	0.06	0.10	0.50	0.51
s, saturation flow rate [veh/h]	5134	3535	1579	3514	6863	2773	3459	3512	2752	5205	1870	1813
c, Capacity [veh/h]	716	1073	479	450	2004	810	473	1048	1273	727	564	546
d1, Uniform Delay [s]	49.51	36.96	42.49	48.06	39.04	32.93	47.26	33.61	18.84	50.71	42.89	42.89
k, delay calibration	0.04	0.15	0.50	0.04	0.15	0.15	0.04	0.11	0.11	0.04	0.50	0.50
l, Upstream Filtering Factor	1.00	1.00	1.00	1.00	1.00	1.00	1.00	1.00	1.00	1.00	1.00	1.00
d2, Incremental Delay [s]	0.29	0.91	311.47	0.09	0.73	0.20	0.09	0.19	0.04	0.58	302.87	326.23
d3, Initial Queue Delay [s]	0.00	0.00	0.00	0.00	0.00	0.00	0.00	0.00	0.00	0.00	0.00	0.00
Rp, platoon ratio	1.00	1.00	1.00	1.00	1.00	1.00	1.00	1.00	1.00	1.00	1.00	1.00
PF, progression factor	1.00	1.00	1.00	1.00	1.00	1.00	1.00	1.00	1.00	1.00	1.00	1.00

**Lane Group Results**

X, volume / capacity	0.59	0.64	1.67	0.23	0.73	0.23	0.23	0.34	0.13	0.74	1.66	1.71
d, Delay for Lane Group [s/veh]	49.79	37.87	353.96	48.16	39.76	33.13	47.36	33.80	18.89	51.29	345.76	369.12
Lane Group LOS	D	D	F	D	D	C	D	C	B	D	F	F
Critical Lane Group	No	No	Yes	Yes	No	No	Yes	No	No	No	No	Yes
50th-Percentile Queue Length [veh/ln]	4.05	9.00	55.68	1.39	9.68	2.06	1.50	4.08	1.29	5.26	63.89	65.48
50th-Percentile Queue Length [ft/ln]	101.18	224.95	1391.99	34.77	241.98	51.41	37.52	102.02	32.16	131.60	1597.25	1637.12
95th-Percentile Queue Length [veh/ln]	7.29	13.92	86.68	2.50	14.78	3.70	2.70	7.35	2.32	9.03	98.24	101.32
95th-Percentile Queue Length [ft/ln]	182.13	347.94	2167.04	62.58	369.53	92.53	67.53	183.64	57.89	225.67	2455.92	2532.99



**Movement, Approach, & Intersection Results**

d_M, Delay for Movement [s/veh]	49.79	37.87	353.96	48.16	39.76	33.13	47.36	33.80	18.89	51.29	356.35	369.12
Movement LOS	D	D	F	D	D	C	D	C	B	D	F	F
d_A, Approach Delay [s/veh]	173.26			39.56			32.37			288.63		
Approach LOS	F			D			C			F		
d_I, Intersection Delay [s/veh]	166.80											
Intersection LOS	F											
Intersection V/C	1.201											

**Emissions**

Vehicle Miles Traveled [mph]	86.15	140.72	164.31	29.42	419.31	52.77	97.60	312.16	141.57	650.91	1122.54	1122.54
Stops [stops/h]	356.66	528.62	1635.54	81.70	1137.26	120.80	88.16	239.75	75.58	463.88	1876.71	1923.56
Fuel consumption [US gal/h]	9.77	14.00	73.48	2.86	37.96	4.31	5.43	15.98	6.43	33.52	124.28	129.17
CO [g/h]	683.10	978.56	5136.48	199.61	2653.13	301.33	379.69	1116.88	449.62	2342.97	8687.15	9029.23
NOx [g/h]	132.91	190.39	999.37	38.84	516.20	58.63	73.87	217.30	87.48	455.86	1690.20	1756.76
VOC [g/h]	158.31	226.79	1190.43	46.26	614.89	69.84	88.00	258.85	104.20	543.01	2013.33	2092.61

**Other Modes**

g_Walk,mi, Effective Walk Time [s]	-6.0		8.0		8.0		8.0	
M_corner, Corner Circulation Area [ft <sup>2</sup> /ped]	0.00		0.00		0.00		0.00	
M_CW, Crosswalk Circulation Area [ft <sup>2</sup> /ped]	0.00		0.00		0.00		0.00	
d_p, Pedestrian Delay [s]	67.43		53.54		53.54		53.54	
I_p,int, Pedestrian LOS Score for Intersectio	3.389		3.334		3.290		3.338	
Crosswalk LOS	C		C		C		C	
s_b, Saturation Flow Rate of the bicycle lane	2000		2000		2000		2000	
c_b, Capacity of the bicycle lane [bicycles/h]	571		571		571		571	
d_b, Bicycle Delay [s]	31.29		31.28		31.28		31.28	
I_b,int, Bicycle LOS Score for Intersection	3.133		2.277		2.077		3.545	
Bicycle LOS	C		B		B		D	

**Sequence**

Ring 1	1	2	3	4	-	-	-	-	-	-	-	-	-	-	-
Ring 2	5	6	7	8	-	-	-	-	-	-	-	-	-	-	-
Ring 3	-	-	-	-	-	-	-	-	-	-	-	-	-	-	-
Ring 4	-	-	-	-	-	-	-	-	-	-	-	-	-	-	-

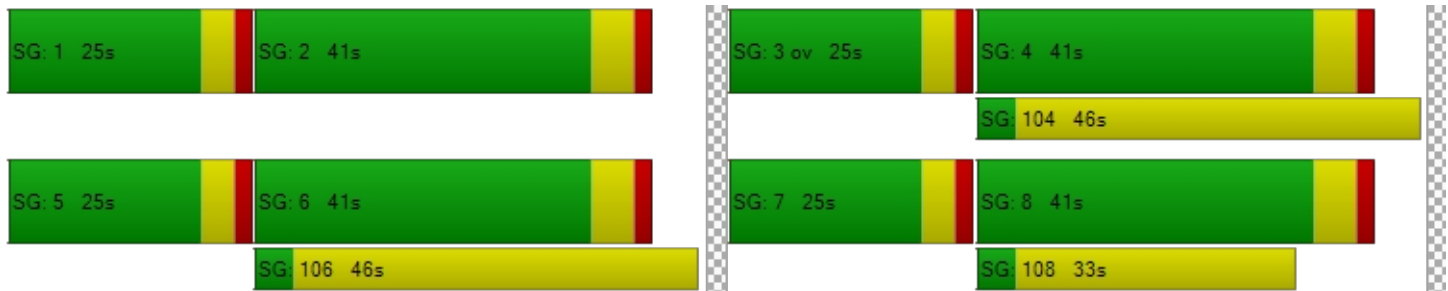

**Intersection Level Of Service Report**  
**Intersection 4: Tassajara Road & I-580 WB Ramps**

Control Type:	Signalized	Delay (sec / veh):	15.9
Analysis Method:	HCM 7th Edition	Level Of Service:	B
Analysis Period:	15 minutes	Volume to Capacity (v/c):	0.782

**Intersection Setup**

Name	Tassajara Road		Tassajara Road		I-580 WB Ramps	
Approach	Northbound		Southbound		Westbound	
Lane Configuration	↑↑		↑↑↑		←↑↑↑	
Turning Movement	Thru	Right	Left	Thru	Left	Right
Lane Width [ft]	12.00	12.00	12.00	12.00	12.00	12.00
No. of Lanes in Entry Pocket	0	0	0	0	1	1
Entry Pocket Length [ft]	100.00	100.00	100.00	100.00	100.00	100.00
No. of Lanes in Exit Pocket	0	1	0	0	0	0
Exit Pocket Length [ft]	0.00	49.21	0.00	0.00	0.00	0.00
Speed [mph]	30.00		30.00		30.00	
Grade [%]	0.00		0.00		0.00	
Curb Present	No		No		No	
Crosswalk	Yes		Yes		Yes	



**Volumes**

Name	Tassajara Road		Tassajara Road		I-580 WB Ramps	
Base Volume Input [veh/h]	1823	0	0	931	631	374
Base Volume Adjustment Factor	1.0000	1.0000	1.0000	1.0000	1.0000	1.0000
Heavy Vehicles Percentage [%]	2.30	2.00	2.00	1.80	2.90	4.00
Proportion of CAVs [%]	0.00					
Growth Factor	1.0000	1.0000	1.0000	1.0000	1.0000	1.0000
In-Process Volume [veh/h]	0	0	0	0	0	0
Site-Generated Trips [veh/h]	0	0	0	0	0	0
Diverted Trips [veh/h]	0	0	0	0	0	0
Pass-by Trips [veh/h]	0	0	0	0	0	0
Existing Site Adjustment Volume [veh/h]	0	0	0	0	0	0
Other Volume [veh/h]	0	0	0	0	0	0
Right Turn on Red Volume [veh/h]	0	0	0	0	0	0
Total Hourly Volume [veh/h]	1823	0	0	931	631	374
Peak Hour Factor	0.9800	1.0000	1.0000	0.9800	0.9800	0.9800
Other Adjustment Factor	1.0000	1.0000	1.0000	1.0000	1.0000	1.0000
Total 15-Minute Volume [veh/h]	465	0	0	238	161	95
Total Analysis Volume [veh/h]	1860	0	0	950	644	382
Presence of On-Street Parking	No	No	No	No	No	No
On-Street Parking Maneuver Rate [/h]	0	0	0	0	0	0
Local Bus Stopping Rate [/h]	0	0	0	0	0	0
v_do, Outbound Pedestrian Volume crossing	0		0		0	
v_di, Inbound Pedestrian Volume crossing m	0		0		0	
v_co, Outbound Pedestrian Volume crossing	0		0		0	
v_ci, Inbound Pedestrian Volume crossing mi	0		0		0	
v_ab, Corner Pedestrian Volume [ped/h]	0		0		0	
Bicycle Volume [bicycles/h]	0		0		0	



**Intersection Settings**

Located in CBD	No
Signal Coordination Group	-
Cycle Length [s]	60
Active Pattern	Pattern 1
Coordination Type	Time of Day Pattern Coordinated
Actuation Type	Fully actuated
Offset [s]	20.0
Offset Reference	Beginning of First Yellow
Permissive Mode	SingleBand
Lost time [s]	6.00

**Phasing & Timing (Basic)**

Control Type	Permissive	Permissive	Permissive	Permissive	Split	Split
Signal Group	6	0	0	2	4	0
Auxiliary Signal Groups						
Maximum Green [s]	40	0	0	40	20	0
Amber [s]	4.9	0.0	0.0	4.9	4.4	0.0
All red [s]	1.0	0.0	0.0	1.0	1.0	0.0
Walk [s]	5	0	0	0	0	0
Pedestrian Clearance [s]	16	0	0	0	0	0
Delayed Vehicle Green [s]	0.0	0.0	0.0	0.0	0.0	0.0
Rest In Walk	No			No	No	
I1, Start-Up Lost Time [s]	2.0	0.0	0.0	2.0	2.0	0.0
I2, Clearance Lost Time [s]	3.9	0.0	0.0	3.9	3.4	0.0
Detector Location [ft]	0.0	0.0	0.0	0.0	0.0	0.0
Detector Length [ft]	20.0	0.0	0.0	20.0	20.0	0.0
I, Upstream Filtering Factor	1.00	1.00	1.00	1.00	1.00	1.00

**Phasing & Timing: Pattern 1**

Split [s]	38	0	0	38	22	0
Lead / Lag	-	-	-	-	Lead	-
Minimum Green [s]	7	0	0	7	4	0
Vehicle Extension [s]	3.0	0.0	0.0	3.0	2.0	0.0
Minimum Recall	No			No	No	
Maximum Recall	Yes			Yes	No	
Pedestrian Recall	Yes			No	No	

**Exclusive Pedestrian Phase**

Pedestrian Signal Group	0
Pedestrian Walk [s]	0
Pedestrian Clearance [s]	0



**Lane Group Calculations**

Lane Group	C	C	L	R
C, Cycle Length [s]	66	66	66	66
L, Total Lost Time per Cycle [s]	5.90	5.90	5.40	5.40
l1_p, Permitted Start-Up Lost Time [s]	0.00	0.00	0.00	0.00
l2, Clearance Lost Time [s]	3.90	3.90	3.40	3.40
g_i, Effective Green Time [s]	40	40	15	15
g / C, Green / Cycle	0.61	0.61	0.22	0.22
(v / s)_i Volume / Saturation Flow Rate	0.52	0.19	0.19	0.14
s, saturation flow rate [veh/h]	3552	5102	3434	2768
c, Capacity [veh/h]	2150	3089	767	619
d1, Uniform Delay [s]	10.80	6.32	24.51	23.11
k, delay calibration	0.50	0.50	0.04	0.04
l, Upstream Filtering Factor	1.00	1.00	1.00	1.00
d2, Incremental Delay [s]	4.96	0.26	0.97	0.38
d3, Initial Queue Delay [s]	0.00	0.00	0.00	0.00
Rp, platoon ratio	1.00	1.00	1.00	1.00
PF, progression factor	1.00	1.00	1.00	1.00

**Lane Group Results**

X, volume / capacity	0.86	0.31	0.84	0.62
d, Delay for Lane Group [s/veh]	15.75	6.58	25.48	23.48
Lane Group LOS	B	A	C	C
Critical Lane Group	Yes	No	Yes	No
50th-Percentile Queue Length [veh/ln]	9.95	1.76	4.61	2.55
50th-Percentile Queue Length [ft/ln]	248.84	44.07	115.20	63.77
95th-Percentile Queue Length [veh/ln]	15.13	3.17	8.13	4.59
95th-Percentile Queue Length [ft/ln]	378.19	79.32	203.21	114.78

**Movement, Approach, & Intersection Results**

d_M, Delay for Movement [s/veh]	15.75	0.00	0.00	6.58	25.48	23.48
Movement LOS	B			A	C	C
d_A, Approach Delay [s/veh]	15.75		6.58		24.74	
Approach LOS	B		A		C	
d_I, Intersection Delay [s/veh]	15.88					
Intersection LOS	B					
Intersection V/C	0.782					

**Emissions**

Vehicle Miles Traveled [mph]	313.20	194.87	52.08	30.89
Stops [stops/h]	1085.72	288.41	502.63	278.23
Fuel consumption [US gal/h]	24.85	10.89	8.26	4.63
CO [g/h]	1737.34	761.04	577.43	323.94
NOx [g/h]	338.02	148.07	112.35	63.03
VOC [g/h]	402.65	176.38	133.83	75.08

**Other Modes**

g_Walk,mi, Effective Walk Time [s]	16.6	16.6	9.0
M_corner, Corner Circulation Area [ft <sup>2</sup> /ped]	0.00	0.00	0.00
M_CW, Crosswalk Circulation Area [ft <sup>2</sup> /ped]	0.00	0.00	0.00
d_p, Pedestrian Delay [s]	18.49	18.49	24.62
I_p,int, Pedestrian LOS Score for Intersectio	2.948	2.897	2.486
Crosswalk LOS	C	C	B
s_b, Saturation Flow Rate of the bicycle lane	2000	2000	2000
c_b, Capacity of the bicycle lane [bicycles/h]	973	973	503
d_b, Bicycle Delay [s]	8.71	8.71	18.49
I_b,int, Bicycle LOS Score for Intersection	3.094	2.082	1.560
Bicycle LOS	C	B	A

**Sequence**

Ring 1	-	2	-	4	-	-	-	-	-	-	-	-	-	-	-	-
Ring 2	-	6	-	-	-	-	-	-	-	-	-	-	-	-	-	-
Ring 3	-	-	-	-	-	-	-	-	-	-	-	-	-	-	-	-
Ring 4	-	-	-	-	-	-	-	-	-	-	-	-	-	-	-	-



**Intersection Level Of Service Report**  
**Intersection 5: Santa Rita Rd & I-580 EB Ramps/Pimlico Dr**

Control Type:	Signalized	Delay (sec / veh):	36.3
Analysis Method:	HCM 7th Edition	Level Of Service:	D
Analysis Period:	15 minutes	Volume to Capacity (v/c):	0.812

**Intersection Setup**

Name	Santa Rita Road			Tassajara Road			I-580 EB Ramps			Pimlico Drive		
Approach	Northbound			Southbound			Eastbound			Westbound		
Lane Configuration	↑			↵			↵↑			↵↵↵↑		
Turning Movement	Left	Thru	Right	Left	Thru	Right	Left	Thru	Right	Left	Thru	Right
Lane Width [ft]	12.00	12.00	12.00	12.00	12.00	12.00	12.00	12.00	12.00	12.00	12.00	12.00
No. of Lanes in Entry Pocket	0	0	1	1	0	0	1	0	0	2	0	1
Entry Pocket Length [ft]	100.00	100.00	250.00	425.00	100.00	100.00	625.00	100.00	100.00	200.00	100.00	250.00
No. of Lanes in Exit Pocket	0	0	0	0	0	2	0	0	0	0	0	0
Exit Pocket Length [ft]	0.00	0.00	0.00	0.00	0.00	49.21	0.00	0.00	0.00	0.00	0.00	0.00
Speed [mph]	30.00			30.00			30.00			30.00		
Grade [%]	0.00			0.00			0.00			0.00		
Curb Present	No			No			No			No		
Crosswalk	Yes			No			Yes			Yes		





**Volumes**

Name	Santa Rita Road			Tassajara Road			I-580 EB Ramps			Pimlico Drive		
Base Volume Input [veh/h]	0	1186	88	165	1235	0	936	136	0	142	0	303
Base Volume Adjustment Factor	1.0000	1.0000	1.0000	1.0000	1.0000	1.0000	1.0000	1.0000	1.0000	1.0000	1.0000	1.0000
Heavy Vehicles Percentage [%]	2.00	3.30	2.40	1.80	2.30	2.00	2.10	2.40	2.00	0.70	2.00	2.40
Proportion of CAVs [%]	0.00											
Growth Factor	1.0000	1.0000	1.0000	1.0000	1.0000	1.0000	1.0000	1.0000	1.0000	1.0000	1.0000	1.0000
In-Process Volume [veh/h]	0	0	0	0	0	0	0	0	0	0	0	0
Site-Generated Trips [veh/h]	0	0	0	0	0	0	0	0	0	0	0	0
Diverted Trips [veh/h]	0	0	0	0	0	0	0	0	0	0	0	0
Pass-by Trips [veh/h]	0	0	0	0	0	0	0	0	0	0	0	0
Existing Site Adjustment Volume [veh/h]	0	0	0	0	0	0	0	0	0	0	0	0
Other Volume [veh/h]	0	0	0	0	0	0	0	0	0	0	0	0
Right Turn on Red Volume [veh/h]	0	0	0	0	0	0	0	0	0	0	0	0
Total Hourly Volume [veh/h]	0	1186	88	165	1235	0	936	136	0	142	0	303
Peak Hour Factor	1.0000	0.9600	0.9600	0.9600	0.9600	1.0000	0.9600	0.9600	1.0000	0.9600	1.0000	0.9600
Other Adjustment Factor	1.0000	1.0000	1.0000	1.0000	1.0000	1.0000	1.0000	1.0000	1.0000	1.0000	1.0000	1.0000
Total 15-Minute Volume [veh/h]	0	309	23	43	322	0	244	35	0	37	0	79
Total Analysis Volume [veh/h]	0	1235	92	172	1286	0	975	142	0	148	0	316
Presence of On-Street Parking	No		No	No		No	No		No	No		No
On-Street Parking Maneuver Rate [/h]	0	0	0	0	0	0	0	0	0	0	0	0
Local Bus Stopping Rate [/h]	0	0	0	0	0	0	0	0	0	0	0	0
v_do, Outbound Pedestrian Volume crossing	5			0			5			0		
v_di, Inbound Pedestrian Volume crossing m	5			0			5			0		
v_co, Outbound Pedestrian Volume crossing	0			2			2			1		
v_ci, Inbound Pedestrian Volume crossing mi	1			2			2			0		
v_ab, Corner Pedestrian Volume [ped/h]	0			0			0			0		
Bicycle Volume [bicycles/h]	0			0			0			0		



**Intersection Settings**

Located in CBD	No
Signal Coordination Group	-
Cycle Length [s]	120
Active Pattern	Pattern 1
Coordination Type	Time of Day Pattern Coordinated
Actuation Type	Fully actuated
Offset [s]	20.0
Offset Reference	Lead Green - Beginning of First Green
Permissive Mode	SingleBand
Lost time [s]	12.00

**Phasing & Timing (Basic)**

Control Type	Permiss	Permiss	Permiss	Protecte	Permiss	Permiss	Protecte	Permiss	Permiss	Permiss	Permiss	Overlap
Signal Group	0	6	0	5	2	0	3	8	0	7	0	4
Auxiliary Signal Groups												4,5
Maximum Green [s]	0	30	0	20	30	0	35	20	0	20	0	20
Amber [s]	0.0	4.4	0.0	3.0	4.4	0.0	4.4	4.4	0.0	3.5	0.0	3.5
All red [s]	0.0	1.0	0.0	1.0	1.0	0.0	1.0	1.0	0.0	1.0	0.0	1.0
Walk [s]	0	5	0	0	5	0	0	5	0	0	0	0
Pedestrian Clearance [s]	0	25	0	0	8	0	0	25	0	0	0	0
Delayed Vehicle Green [s]	0.0	0.0	0.0	0.0	0.0	0.0	0.0	0.0	0.0	0.0	0.0	0.0
Rest In Walk		No			No			No		No		
I1, Start-Up Lost Time [s]	0.0	2.0	0.0	2.0	2.0	0.0	2.0	2.0	0.0	2.0	0.0	2.0
I2, Clearance Lost Time [s]	0.0	3.4	0.0	2.0	3.4	0.0	3.4	3.4	0.0	2.5	0.0	2.5
Detector Location [ft]	0.0	0.0	0.0	0.0	0.0	0.0	0.0	0.0	0.0	0.0	0.0	0.0
Detector Length [ft]	0.0	20.0	0.0	20.0	20.0	0.0	20.0	20.0	0.0	20.0	0.0	0.0
I, Upstream Filtering Factor	1.00	1.00	1.00	1.00	1.00	1.00	1.00	1.00	1.00	1.00	1.00	1.00

**Phasing & Timing: Pattern 1**

Split [s]	0	41	0	25	66	0	40	36	0	18	0	14
Lead / Lag	-	-	-	Lead	-	-	Lead	-	-	Lead	-	-
Minimum Green [s]	0	7	0	5	7	0	5	5	0	5	0	5
Vehicle Extension [s]	0.0	3.0	0.0	3.0	3.0	0.0	3.0	2.0	0.0	3.0	0.0	2.0
Minimum Recall		No		No	No		No	No		No		No
Maximum Recall		Yes		No	Yes		No	No		No		No
Pedestrian Recall		No		No	Yes		No	No		No		No

**Exclusive Pedestrian Phase**

Pedestrian Signal Group	0
Pedestrian Walk [s]	0
Pedestrian Clearance [s]	0



**Lane Group Calculations**

Lane Group	C	C	L	C	L	C	L	R
C, Cycle Length [s]	120	120	120	120	120	120	120	120
L, Total Lost Time per Cycle [s]	5.40	5.40	4.00	5.40	5.40	5.40	4.50	4.00
l1_p, Permitted Start-Up Lost Time [s]	0.00	0.00	0.00	0.00	0.00	0.00	0.00	0.00
l2, Clearance Lost Time [s]	3.40	3.40	2.00	3.40	3.40	3.40	2.50	0.00
g_i, Effective Green Time [s]	46	46	14	64	35	33	7	24
g / C, Green / Cycle	0.39	0.39	0.12	0.53	0.29	0.28	0.06	0.20
(v / s)_i Volume / Saturation Flow Rate	0.25	0.19	0.10	0.36	0.28	0.08	0.04	0.11
s, saturation flow rate [veh/h]	4053	1763	1784	3552	3456	1864	3495	2804
c, Capacity [veh/h]	1561	679	207	1899	997	516	213	569
d1, Uniform Delay [s]	30.04	27.91	51.85	20.36	42.30	33.93	55.23	42.93
k, delay calibration	0.50	0.50	0.13	0.50	0.11	0.04	0.11	0.04
l, Upstream Filtering Factor	1.00	1.00	1.00	1.00	1.00	1.00	1.00	1.00
d2, Incremental Delay [s]	2.00	2.50	9.73	1.96	9.10	0.11	4.08	0.32
d3, Initial Queue Delay [s]	0.00	0.00	0.00	0.00	0.00	0.00	0.00	0.00
Rp, platoon ratio	1.00	1.00	1.00	1.00	1.00	1.00	1.00	1.00
PF, progression factor	1.00	1.00	1.00	1.00	1.00	1.00	1.00	1.00

**Lane Group Results**

X, volume / capacity	0.64	0.49	0.83	0.68	0.98	0.28	0.70	0.56
d, Delay for Lane Group [s/veh]	32.04	30.41	61.58	22.32	51.40	34.03	59.30	43.25
Lane Group LOS	C	C	E	C	D	C	E	D
Critical Lane Group	No	No	No	Yes	Yes	No	No	Yes
50th-Percentile Queue Length [veh/ln]	8.03	7.66	5.62	13.24	15.41	3.27	2.32	4.24
50th-Percentile Queue Length [ft/ln]	200.73	191.60	140.42	330.98	385.13	81.87	57.90	106.01
95th-Percentile Queue Length [veh/ln]	12.68	12.20	9.50	19.21	21.84	5.89	4.17	7.62
95th-Percentile Queue Length [ft/ln]	316.91	305.10	237.59	480.17	546.05	147.36	104.22	190.44

**Movement, Approach, & Intersection Results**

d_M, Delay for Movement [s/veh]	0.00	31.72	30.41	61.58	22.32	0.00	51.40	34.03	0.00	59.30	0.00	43.25
Movement LOS		C	C	E	C		D	C		E		D
d_A, Approach Delay [s/veh]	31.63			26.95			49.19			48.37		
Approach LOS	C			C			D			D		
d_I, Intersection Delay [s/veh]	36.34											
Intersection LOS	D											
Intersection V/C	0.812											

**Emissions**

Vehicle Miles Traveled [mph]	98.16	32.72	28.96	216.55	135.29	19.70	12.63	26.97
Stops [stops/h]	722.87	230.00	168.56	794.63	924.62	98.27	139.01	254.51
Fuel consumption [US gal/h]	14.52	4.67	4.28	19.15	20.88	2.34	3.07	5.30
CO [g/h]	1015.19	326.49	299.08	1338.29	1459.18	163.39	214.87	370.27
NOx [g/h]	197.52	63.52	58.19	260.38	283.90	31.79	41.80	72.04
VOC [g/h]	235.28	75.67	69.32	310.16	338.18	37.87	49.80	85.81

**Other Modes**

g_Walk,mi, Effective Walk Time [s]	9.0	0.0	9.0	9.0
M_corner, Corner Circulation Area [ft <sup>2</sup> /ped]	0.00	0.00	0.00	0.00
M_CW, Crosswalk Circulation Area [ft <sup>2</sup> /ped]	653.31	0.00	0.00	0.00
d_p, Pedestrian Delay [s]	51.32	0.00	51.32	51.32
I_p,int, Pedestrian LOS Score for Intersectio	2.917	0.000	2.419	2.485
Crosswalk LOS	C	F	B	B
s_b, Saturation Flow Rate of the bicycle lane	2000	2000	2000	2000
c_b, Capacity of the bicycle lane [bicycles/h]	594	1010	510	225
d_b, Bicycle Delay [s]	29.66	14.69	33.28	47.24
I_b,int, Bicycle LOS Score for Intersection	2.107	2.762	3.403	1.560
Bicycle LOS	B	C	C	A

**Sequence**

Ring 1	-	2	3	4	-	-	-	-	-	-	-	-	-	-	-
Ring 2	5	6	7	8	-	-	-	-	-	-	-	-	-	-	-
Ring 3	-	-	-	-	-	-	-	-	-	-	-	-	-	-	-
Ring 4	-	-	-	-	-	-	-	-	-	-	-	-	-	-	-

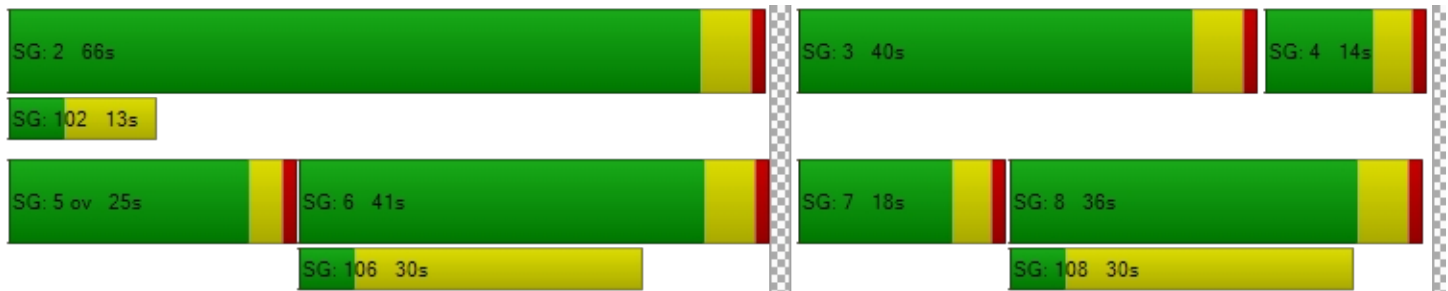

**Intersection Level Of Service Report**  
**Intersection 6: Tassajara Road & Fallon Road**

Control Type:	Signalized	Delay (sec / veh):	26.4
Analysis Method:	HCM 7th Edition	Level Of Service:	C
Analysis Period:	15 minutes	Volume to Capacity (v/c):	0.702

**Intersection Setup**

Name	Fallon Road			Fallon Road			Tassajara Road			Syrah Drive		
Approach	Northbound			Southbound			Eastbound			Westbound		
Lane Configuration												
Turning Movement	Left	Thru	Right	Left	Thru	Right	Left	Thru	Right	Left	Thru	Right
Lane Width [ft]	12.00	12.00	12.00	12.00	12.00	12.00	12.00	12.00	12.00	12.00	12.00	12.00
No. of Lanes in Entry Pocket	1	0	1	1	0	2	1	0	1	1	0	1
Entry Pocket Length [ft]	175.00	100.00	175.00	175.00	100.00	225.00	475.00	100.00	175.00	100.00	100.00	100.00
No. of Lanes in Exit Pocket	0	0	0	0	0	0	0	0	0	0	0	0
Exit Pocket Length [ft]	0.00	0.00	0.00	0.00	0.00	0.00	0.00	0.00	0.00	0.00	0.00	0.00
Speed [mph]	30.00			30.00			30.00			30.00		
Grade [%]	0.00			0.00			0.00			0.00		
Curb Present	No			No			No			No		
Crosswalk	Yes			Yes			Yes			Yes		



**Volumes**

Name	Fallon Road			Fallon Road			Tassajara Road			Syrah Drive		
Base Volume Input [veh/h]	219	415	13	2	546	590	255	12	206	24	33	12
Base Volume Adjustment Factor	1.0000	1.0000	1.0000	1.0000	1.0000	1.0000	1.0000	1.0000	1.0000	1.0000	1.0000	1.0000
Heavy Vehicles Percentage [%]	1.00	1.70	0.00	0.00	0.60	0.20	1.40	0.00	0.50	0.00	0.00	0.00
Proportion of CAVs [%]	0.00											
Growth Factor	1.0000	1.0000	1.0000	1.0000	1.0000	1.0000	1.0000	1.0000	1.0000	1.0000	1.0000	1.0000
In-Process Volume [veh/h]	0	0	0	0	0	0	0	0	0	0	0	0
Site-Generated Trips [veh/h]	0	0	0	0	0	0	0	0	0	0	0	0
Diverted Trips [veh/h]	0	0	0	0	0	0	0	0	0	0	0	0
Pass-by Trips [veh/h]	0	0	0	0	0	0	0	0	0	0	0	0
Existing Site Adjustment Volume [veh/h]	0	0	0	0	0	0	0	0	0	0	0	0
Other Volume [veh/h]	0	0	0	0	0	0	0	0	0	0	0	0
Right Turn on Red Volume [veh/h]	0	0	0	0	0	0	0	0	0	0	0	0
Total Hourly Volume [veh/h]	219	415	13	2	546	590	255	12	206	24	33	12
Peak Hour Factor	0.7800	0.7800	0.7800	0.7800	0.7800	0.7800	0.7800	0.7800	0.7800	0.7800	0.7800	0.7800
Other Adjustment Factor	1.0000	1.0000	1.0000	1.0000	1.0000	1.0000	1.0000	1.0000	1.0000	1.0000	1.0000	1.0000
Total 15-Minute Volume [veh/h]	70	133	4	1	175	189	82	4	66	8	11	4
Total Analysis Volume [veh/h]	281	532	17	3	700	756	327	15	264	31	42	15
Presence of On-Street Parking	No		No	No		No	No		No	No		No
On-Street Parking Maneuver Rate [/h]	0	0	0	0	0	0	0	0	0	0	0	0
Local Bus Stopping Rate [/h]	0	0	0	0	0	0	0	0	0	0	0	0
v_do, Outbound Pedestrian Volume crossing	1			0			0			0		
v_di, Inbound Pedestrian Volume crossing m	0			0			1			0		
v_co, Outbound Pedestrian Volume crossing	0			0			1			0		
v_ci, Inbound Pedestrian Volume crossing mi	0			1			0			0		
v_ab, Corner Pedestrian Volume [ped/h]	0			0			0			0		
Bicycle Volume [bicycles/h]	0			0			0			0		



**Intersection Settings**

Located in CBD	No
Signal Coordination Group	-
Cycle Length [s]	90
Active Pattern	Free Running (No Pattern)
Coordination Type	<i>Free Running</i>
Actuation Type	<i>Fully actuated</i>
Offset [s]	0.0
Offset Reference	Lead Green - Beginning of First Green
Permissive Mode	SingleBand
Lost time [s]	12.00

**Phasing & Timing (Basic)**

Control Type	Protecte	Permiss	Permiss	Protecte	Permiss	Permiss	Protecte	Permiss	Permiss	Protecte	Permiss	Permiss
Signal Group	3	8	0	7	4	0	5	2	0	1	6	0
Auxiliary Signal Groups												
Maximum Green [s]	25	50	0	25	50	0	35	30	0	20	30	0
Amber [s]	3.5	4.8	0.0	3.5	4.8	0.0	3.5	5.0	0.0	3.0	3.6	0.0
All red [s]	1.0	1.0	0.0	1.0	1.0	0.0	1.0	1.0	0.0	1.0	1.0	0.0
Walk [s]	0	4	0	0	0	0	0	4	0	0	3	0
Pedestrian Clearance [s]	0	25	0	0	0	0	0	28	0	0	36	0
Delayed Vehicle Green [s]	0.0	0.0	0.0	0.0	0.0	0.0	0.0	0.0	0.0	0.0	0.0	0.0
Rest In Walk		No			No			No			No	
I1, Start-Up Lost Time [s]	2.0	2.0	0.0	2.0	2.0	0.0	2.0	2.0	0.0	2.0	2.0	0.0
I2, Clearance Lost Time [s]	2.0	2.0	0.0	2.0	2.0	0.0	2.0	2.0	0.0	2.0	2.0	0.0
Detector Location [ft]	0.0	0.0	0.0	0.0	0.0	0.0	0.0	0.0	0.0	0.0	0.0	0.0
Detector Length [ft]	0.0	0.0	0.0	0.0	0.0	0.0	0.0	0.0	0.0	0.0	0.0	0.0
I, Upstream Filtering Factor	1.00	1.00	1.00	1.00	1.00	1.00	1.00	1.00	1.00	1.00	1.00	1.00

**Phasing & Timing: Free Running (No Pattern)**

Split [s]	0	0	0	0	0	0	0	0	0	0	0	0
Lead / Lag	Lead	-	-	Lead	-	-	Lead	-	-	Lead	-	-
Minimum Green [s]	9	10	0	9	10	0	11	8	0	12	9	0
Vehicle Extension [s]	3.0	3.0	0.0	3.0	3.0	0.0	3.0	3.0	0.0	3.0	3.0	0.0
Minimum Recall	No	No		No	No		Yes	No		No	No	
Maximum Recall	No	No		No	No		No	No		No	No	
Pedestrian Recall	No	No		No	No		No	No		No	No	

**Exclusive Pedestrian Phase**

Pedestrian Signal Group	0
Pedestrian Walk [s]	0
Pedestrian Clearance [s]	0



**Lane Group Calculations**

Lane Group	L	C	R	L	C	R	L	C	R	L	C	R
C, Cycle Length [s]	85	85	85	85	85	85	85	85	85	85	85	85
L, Total Lost Time per Cycle [s]	4.00	4.00	4.00	4.00	4.00	4.00	4.00	4.00	4.00	4.00	4.00	4.00
l1_p, Permitted Start-Up Lost Time [s]	0.00	0.00	0.00	0.00	0.00	0.00	0.00	0.00	0.00	0.00	0.00	0.00
l2, Clearance Lost Time [s]	2.00	2.00	2.00	2.00	2.00	2.00	2.00	2.00	2.00	2.00	2.00	2.00
g_i, Effective Green Time [s]	16	43	43	1	29	29	11	18	18	6	13	13
g / C, Green / Cycle	0.19	0.51	0.51	0.01	0.34	0.34	0.14	0.21	0.21	0.07	0.15	0.15
(v / s)_i Volume / Saturation Flow Rate	0.16	0.15	0.01	0.00	0.19	0.26	0.09	0.01	0.16	0.02	0.02	0.01
s, saturation flow rate [veh/h]	1795	3569	1615	1810	3600	2854	3475	1900	1606	1810	1900	1615
c, Capacity [veh/h]	335	1830	828	24	1222	968	471	403	341	133	286	243
d1, Uniform Delay [s]	33.31	11.85	10.19	41.41	23.01	25.21	35.04	26.56	31.53	37.08	31.34	30.94
k, delay calibration	0.11	0.11	0.11	0.11	0.11	0.11	0.11	0.11	0.11	0.11	0.11	0.11
l, Upstream Filtering Factor	1.00	1.00	1.00	1.00	1.00	1.00	1.00	1.00	1.00	1.00	1.00	1.00
d2, Incremental Delay [s]	5.61	0.09	0.01	2.34	0.43	1.41	1.86	0.04	3.78	0.88	0.23	0.11
d3, Initial Queue Delay [s]	0.00	0.00	0.00	0.00	0.00	0.00	0.00	0.00	0.00	0.00	0.00	0.00
Rp, platoon ratio	1.00	1.00	1.00	1.00	1.00	1.00	1.00	1.00	1.00	1.00	1.00	1.00
PF, progression factor	1.00	1.00	1.00	1.00	1.00	1.00	1.00	1.00	1.00	1.00	1.00	1.00

**Lane Group Results**

X, volume / capacity	0.84	0.29	0.02	0.13	0.57	0.78	0.70	0.04	0.77	0.23	0.15	0.06
d, Delay for Lane Group [s/veh]	38.92	11.94	10.20	43.75	23.43	26.62	36.89	26.60	35.31	37.96	31.58	31.04
Lane Group LOS	D	B	B	D	C	C	D	C	D	D	C	C
Critical Lane Group	Yes	No	No	No	No	Yes	No	No	Yes	Yes	No	No
50th-Percentile Queue Length [veh/ln]	5.94	2.71	0.15	0.08	5.58	6.71	3.28	0.24	5.31	0.63	0.75	0.27
50th-Percentile Queue Length [ft/ln]	148.62	67.74	3.75	1.92	139.53	167.74	81.88	6.03	132.70	15.75	18.86	6.66
95th-Percentile Queue Length [veh/ln]	9.94	4.88	0.27	0.14	9.46	10.96	5.90	0.43	9.09	1.13	1.36	0.48
95th-Percentile Queue Length [ft/ln]	248.59	121.94	6.75	3.45	236.39	273.94	147.39	10.85	227.16	28.35	33.95	11.99





**Movement, Approach, & Intersection Results**

d_M, Delay for Movement [s/veh]	38.92	11.94	10.20	43.75	23.43	26.62	36.89	26.60	35.31	37.96	31.58	31.04
Movement LOS	D	B	B	D	C	C	D	C	D	D	C	C
d_A, Approach Delay [s/veh]	21.04			25.13			35.95			33.73		
Approach LOS	C			C			D			C		
d_I, Intersection Delay [s/veh]	26.44											
Intersection LOS	C											
Intersection V/C	0.702											

**Emissions**

Vehicle Miles Traveled [mph]	26.78	50.70	1.62	0.33	75.98	82.06	42.17	1.93	34.05	1.11	1.51	0.54
Stops [stops/h]	252.41	230.10	6.37	3.25	473.93	569.75	278.14	10.24	225.37	26.75	32.04	11.32
Fuel consumption [US gal/h]	4.72	4.65	0.14	0.06	9.08	10.62	5.73	0.22	4.54	0.43	0.51	0.18
CO [g/h]	330.09	325.08	9.59	4.06	635.01	742.47	400.36	15.20	317.59	30.27	35.57	12.54
NOx [g/h]	64.22	63.25	1.87	0.79	123.55	144.46	77.90	2.96	61.79	5.89	6.92	2.44
VOC [g/h]	76.50	75.34	2.22	0.94	147.17	172.07	92.79	3.52	73.60	7.02	8.24	2.91

**Other Modes**

g_Walk,mi, Effective Walk Time [s]	8.0			7.0			-5.8			8.0		
M_corner, Corner Circulation Area [ft <sup>2</sup> /ped]	0.00			0.00			0.00			0.00		
M_CW, Crosswalk Circulation Area [ft <sup>2</sup> /ped]	0.00			0.00			0.00			0.00		
d_p, Pedestrian Delay [s]	34.77			35.68			48.39			34.77		
I_p,int, Pedestrian LOS Score for Intersectio	2.749			2.920			2.740			2.161		
Crosswalk LOS	B			C			B			B		
s_b, Saturation Flow Rate of the bicycle lane	2000			2000			2000			2000		
c_b, Capacity of the bicycle lane [bicycles/h]	1179			1179			708			708		
d_b, Bicycle Delay [s]	7.14			7.14			17.70			17.70		
I_b,int, Bicycle LOS Score for Intersection	2.244			2.763			2.560			1.705		
Bicycle LOS	B			C			B			A		

**Sequence**

Ring 1	1	2	3	4	-	-	-	-	-	-	-	-	-	-	-
Ring 2	5	6	7	8	-	-	-	-	-	-	-	-	-	-	-
Ring 3	-	-	-	-	-	-	-	-	-	-	-	-	-	-	-
Ring 4	-	-	-	-	-	-	-	-	-	-	-	-	-	-	-



**Intersection Level Of Service Report**  
**Intersection 7: Fallon Road & Positano Parkway**

Control Type:	Signalized	Delay (sec / veh):	75.0
Analysis Method:	HCM 7th Edition	Level Of Service:	E
Analysis Period:	15 minutes	Volume to Capacity (v/c):	1.049

**Intersection Setup**

Name	Fallon Road		Fallon Road		Positano Parkway	
Approach	Northbound		Southbound		Westbound	
Lane Configuration	↑↑↑↔		↔↑↑↑		↔↔↔	
Turning Movement	Thru	Right	Left	Thru	Left	Right
Lane Width [ft]	12.00	12.00	12.00	12.00	12.00	12.00
No. of Lanes in Entry Pocket	0	1	1	0	1	1
Entry Pocket Length [ft]	100.00	225.00	325.00	100.00	375.00	425.00
No. of Lanes in Exit Pocket	0	0	0	0	0	0
Exit Pocket Length [ft]	0.00	0.00	0.00	0.00	0.00	0.00
Speed [mph]	30.00		30.00		30.00	
Grade [%]	0.00		0.00		0.00	
Curb Present	No		No		No	
Crosswalk	Yes		Yes		Yes	



**Volumes**

Name	Fallon Road		Fallon Road		Positano Parkway	
Base Volume Input [veh/h]	519	182	396	859	609	694
Base Volume Adjustment Factor	1.0000	1.0000	1.0000	1.0000	1.0000	1.0000
Heavy Vehicles Percentage [%]	2.90	0.50	0.30	0.60	0.00	0.70
Proportion of CAVs [%]	0.00					
Growth Factor	1.0000	1.0000	1.0000	1.0000	1.0000	1.0000
In-Process Volume [veh/h]	0	0	0	0	0	0
Site-Generated Trips [veh/h]	0	0	0	0	0	0
Diverted Trips [veh/h]	0	0	0	0	0	0
Pass-by Trips [veh/h]	0	0	0	0	0	0
Existing Site Adjustment Volume [veh/h]	0	0	0	0	0	0
Other Volume [veh/h]	0	0	0	0	0	0
Right Turn on Red Volume [veh/h]	0	0	0	0	0	0
Total Hourly Volume [veh/h]	519	182	396	859	609	694
Peak Hour Factor	0.8400	0.8400	0.8400	0.8400	0.8400	0.8400
Other Adjustment Factor	1.0000	1.0000	1.0000	1.0000	1.0000	1.0000
Total 15-Minute Volume [veh/h]	154	54	118	256	181	207
Total Analysis Volume [veh/h]	618	217	471	1023	725	826
Presence of On-Street Parking	No	No	No	No	No	No
On-Street Parking Maneuver Rate [/h]	0	0	0	0	0	0
Local Bus Stopping Rate [/h]	0	0	0	0	0	0
v_do, Outbound Pedestrian Volume crossing	0		2		2	
v_di, Inbound Pedestrian Volume crossing m	0		2		2	
v_co, Outbound Pedestrian Volume crossing	0		0		1	
v_ci, Inbound Pedestrian Volume crossing mi	1		0		0	
v_ab, Corner Pedestrian Volume [ped/h]	0		0		0	
Bicycle Volume [bicycles/h]	0		0		2	

**Intersection Settings**

Located in CBD	No
Signal Coordination Group	-
Cycle Length [s]	90
Active Pattern	Free Running (No Pattern)
Coordination Type	<i>Free Running</i>
Actuation Type	<i>Fully actuated</i>
Offset [s]	0.0
Offset Reference	Lead Green - Beginning of First Green
Permissive Mode	SingleBand
Lost time [s]	9.00

**Phasing & Timing (Basic)**

Control Type	Permissive	Permissive	Protected	Permissive	Permissive	Permissive
Signal Group	4	0	7	8	6	0
Auxiliary Signal Groups						
Maximum Green [s]	30	0	20	30	24	0
Amber [s]	4.3	0.0	3.5	4.3	4.0	0.0
All red [s]	1.0	0.0	1.0	1.0	1.0	0.0
Walk [s]	0	0	0	4	4	0
Pedestrian Clearance [s]	0	0	0	20	34	0
Delayed Vehicle Green [s]	0.0	0.0	0.0	0.0	0.0	0.0
Rest In Walk	No			No	No	
I1, Start-Up Lost Time [s]	2.0	0.0	2.0	2.0	2.0	0.0
I2, Clearance Lost Time [s]	2.0	0.0	2.0	2.0	2.0	0.0
Detector Location [ft]	0.0	0.0	0.0	0.0	0.0	0.0
Detector Length [ft]	20.0	0.0	20.0	20.0	20.0	0.0
I, Upstream Filtering Factor	1.00	1.00	1.00	1.00	1.00	1.00

**Phasing & Timing: Free Running (No Pattern)**

Split [s]	14	0	9	14	9	0
Lead / Lag	-	-	Lead	-	Lead	-
Minimum Green [s]	10	0	5	10	5	0
Vehicle Extension [s]	3.0	0.0	3.0	3.0	3.0	0.0
Minimum Recall	Yes		No	Yes	No	
Maximum Recall	No		No	No	No	
Pedestrian Recall	No		No	No	No	

**Exclusive Pedestrian Phase**

Pedestrian Signal Group	0
Pedestrian Walk [s]	0
Pedestrian Clearance [s]	0



**Lane Group Calculations**

Lane Group	C	R	L	C	L	R
C, Cycle Length [s]	73	73	73	73	73	73
L, Total Lost Time per Cycle [s]	4.00	4.00	4.00	4.00	4.00	4.00
l1_p, Permitted Start-Up Lost Time [s]	0.00	0.00	0.00	0.00	0.00	0.00
l2, Clearance Lost Time [s]	2.00	2.00	2.00	2.00	2.00	2.00
g_i, Effective Green Time [s]	15	15	21	40	25	25
g / C, Green / Cycle	0.21	0.21	0.28	0.55	0.34	0.34
(v / s)_i Volume / Saturation Flow Rate	0.12	0.14	0.26	0.20	0.21	0.52
s, saturation flow rate [veh/h]	5057	1606	1805	5151	3514	1579
c, Capacity [veh/h]	1065	338	508	2818	1206	542
d1, Uniform Delay [s]	25.85	26.23	25.45	9.33	19.80	23.71
k, delay calibration	0.11	0.11	0.39	0.11	0.11	0.50
l, Upstream Filtering Factor	1.00	1.00	1.00	1.00	1.00	1.00
d2, Incremental Delay [s]	0.50	2.03	21.44	0.08	0.48	245.10
d3, Initial Queue Delay [s]	0.00	0.00	0.00	0.00	0.00	0.00
Rp, platoon ratio	1.00	1.00	1.00	1.00	1.00	1.00
PF, progression factor	1.00	1.00	1.00	1.00	1.00	1.00

**Lane Group Results**

X, volume / capacity	0.58	0.64	0.93	0.36	0.60	1.52
d, Delay for Lane Group [s/veh]	26.36	28.26	46.88	9.41	20.28	268.81
Lane Group LOS	C	C	D	A	C	F
Critical Lane Group	No	Yes	Yes	No	No	Yes
50th-Percentile Queue Length [veh/ln]	3.12	3.47	10.44	2.69	4.83	45.40
50th-Percentile Queue Length [ft/ln]	78.03	86.84	261.02	67.34	120.63	1134.92
95th-Percentile Queue Length [veh/ln]	5.62	6.25	15.74	4.85	8.43	70.45
95th-Percentile Queue Length [ft/ln]	140.45	156.32	393.50	121.22	210.69	1761.15

**Movement, Approach, & Intersection Results**

d_M, Delay for Movement [s/veh]	26.36	28.26	46.88	9.41	20.28	268.81
Movement LOS	C	C	D	A	C	F
d_A, Approach Delay [s/veh]	26.85		21.22		152.64	
Approach LOS	C		C		F	
d_I, Intersection Delay [s/veh]	74.97					
Intersection LOS	E					
Intersection V/C	1.049					

**Emissions**

Vehicle Miles Traveled [mph]	155.43	54.58	41.32	89.75	86.94	99.05
Stops [stops/h]	463.18	171.84	516.47	399.76	477.37	2245.67
Fuel consumption [US gal/h]	12.27	4.44	9.05	7.86	9.21	61.66
CO [g/h]	857.84	310.65	632.44	549.54	643.68	4310.10
NOx [g/h]	166.90	60.44	123.05	106.92	125.24	838.59
VOC [g/h]	198.81	72.00	146.57	127.36	149.18	998.91

**Other Modes**

g_Walk,mi, Effective Walk Time [s]	8.0		8.0		8.7	
M_corner, Corner Circulation Area [ft <sup>2</sup> /ped]	0.00		0.00		0.00	
M_CW, Crosswalk Circulation Area [ft <sup>2</sup> /ped]	0.00		0.00		0.00	
d_p, Pedestrian Delay [s]	28.83		28.83		28.21	
I_p,int, Pedestrian LOS Score for Intersectio	2.946		2.995		2.668	
Crosswalk LOS	C		C		B	
s_b, Saturation Flow Rate of the bicycle lane	2000		2000		2000	
c_b, Capacity of the bicycle lane [bicycles/h]	824		824		660	
d_b, Bicycle Delay [s]	12.57		12.57		16.36	
I_b,int, Bicycle LOS Score for Intersection	2.019		2.381		1.560	
Bicycle LOS	B		B		A	

**Sequence**

Ring 1	-	-	-	8	-	-	-	-	-	-	-	-	-	-	-	-
Ring 2	-	6	7	4	-	-	-	-	-	-	-	-	-	-	-	-
Ring 3	-	-	-	-	-	-	-	-	-	-	-	-	-	-	-	-
Ring 4	-	-	-	-	-	-	-	-	-	-	-	-	-	-	-	-

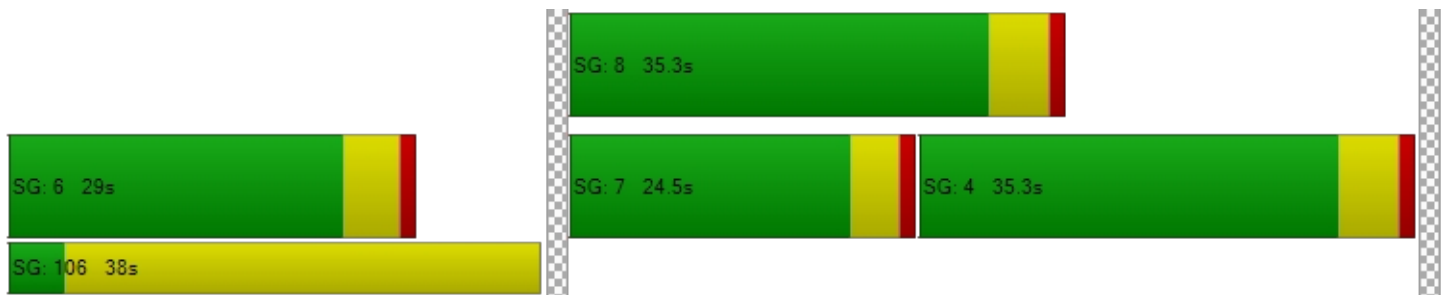

**Intersection Level Of Service Report**  
**Intersection 8: Fallon Road & Central Parkway**

Control Type:	Signalized	Delay (sec / veh):	42.9
Analysis Method:	HCM 7th Edition	Level Of Service:	D
Analysis Period:	15 minutes	Volume to Capacity (v/c):	0.658

**Intersection Setup**

Name	Fallon Road			Fallon Road			Central Parkway			Central Parkway		
Approach	Northbound			Southbound			Eastbound			Westbound		
Lane Configuration												
Turning Movement	Left	Thru	Right	Left	Thru	Right	Left	Thru	Right	Left	Thru	Right
Lane Width [ft]	12.00	12.00	12.00	12.00	12.00	12.00	12.00	12.00	12.00	12.00	12.00	12.00
No. of Lanes in Entry Pocket	2	0	1	1	0	1	2	0	2	2	0	1
Entry Pocket Length [ft]	300.00	100.00	255.00	295.00	100.00	245.00	350.00	100.00	230.00	250.00	100.00	250.00
No. of Lanes in Exit Pocket	0	0	0	0	0	2	0	0	0	0	0	0
Exit Pocket Length [ft]	0.00	0.00	0.00	0.00	0.00	500.00	0.00	0.00	0.00	0.00	0.00	0.00
Speed [mph]	40.00			30.00			25.00			30.00		
Grade [%]	0.00			0.00			0.00			0.00		
Curb Present	Yes			Yes			Yes			Yes		
Crosswalk	Yes			Yes			Yes			Yes		



**Volumes**

Name	Fallon Road			Fallon Road			Central Parkway			Central Parkway		
Base Volume Input [veh/h]	68	680	146	73	1238	67	57	175	111	290	181	84
Base Volume Adjustment Factor	1.0000	1.0000	1.0000	1.0000	1.0000	1.0000	1.0000	1.0000	1.0000	1.0000	1.0000	1.0000
Heavy Vehicles Percentage [%]	6.00	1.20	0.70	0.00	0.40	1.80	0.00	0.60	3.30	0.00	0.60	1.20
Proportion of CAVs [%]	0.00											
Growth Factor	1.0000	1.0000	1.0000	1.0000	1.0000	1.0000	1.0000	1.0000	1.0000	1.0000	1.0000	1.0000
In-Process Volume [veh/h]	0	0	0	0	0	0	0	0	0	0	0	0
Site-Generated Trips [veh/h]	0	0	0	0	0	0	0	0	0	0	0	0
Diverted Trips [veh/h]	0	0	0	0	0	0	0	0	0	0	0	0
Pass-by Trips [veh/h]	0	0	0	0	0	0	0	0	0	0	0	0
Existing Site Adjustment Volume [veh/h]	0	0	0	0	0	0	0	0	0	0	0	0
Other Volume [veh/h]	0	0	0	0	0	0	0	0	0	0	0	0
Right Turn on Red Volume [veh/h]	0	0	0	0	0	0	0	0	0	0	0	0
Total Hourly Volume [veh/h]	68	680	146	73	1238	67	57	175	111	290	181	84
Peak Hour Factor	0.7500	0.7500	0.7500	0.7500	0.7500	0.7500	0.7500	0.7500	0.7500	0.7500	0.7500	0.7500
Other Adjustment Factor	1.0000	1.0000	1.0000	1.0000	1.0000	1.0000	1.0000	1.0000	1.0000	1.0000	1.0000	1.0000
Total 15-Minute Volume [veh/h]	23	227	49	24	413	22	19	58	37	97	60	28
Total Analysis Volume [veh/h]	91	907	195	97	1651	89	76	233	148	387	241	112
Presence of On-Street Parking	No		No	No		No	No		No	No		No
On-Street Parking Maneuver Rate [/h]	0	0	0	0	0	0	0	0	0	0	0	0
Local Bus Stopping Rate [/h]	0	0	0	0	0	0	0	0	0	0	0	0
v_do, Outbound Pedestrian Volume crossing	1			2			2			1		
v_di, Inbound Pedestrian Volume crossing m	1			2			2			1		
v_co, Outbound Pedestrian Volume crossing	44			4			43			4		
v_ci, Inbound Pedestrian Volume crossing mi	43			4			44			4		
v_ab, Corner Pedestrian Volume [ped/h]	0			0			0			0		
Bicycle Volume [bicycles/h]	1			0			6			0		





**Intersection Settings**

Located in CBD	No
Signal Coordination Group	-
Cycle Length [s]	90
Active Pattern	Free Running (No Pattern)
Coordination Type	<i>Free Running</i>
Actuation Type	<i>Fully actuated</i>
Offset [s]	0.0
Offset Reference	Lead Green - Beginning of First Green
Permissive Mode	SingleBand
Lost time [s]	12.00

**Phasing & Timing (Basic)**

Control Type	Protecte	Permiss	Permiss	Protecte	Permiss	Permiss	Protecte	Permiss	Permiss	Protecte	Permiss	Permiss
Signal Group	3	8	0	7	4	0	5	2	0	1	6	0
Auxiliary Signal Groups												
Maximum Green [s]	20	30	0	20	30	0	20	30	0	20	30	0
Amber [s]	3.5	4.3	0.0	3.0	4.3	0.0	3.0	4.0	0.0	3.0	4.0	0.0
All red [s]	1.0	1.0	0.0	1.0	1.0	0.0	1.0	1.0	0.0	1.0	1.0	0.0
Walk [s]	0	4	0	0	4	0	0	4	0	0	4	0
Pedestrian Clearance [s]	0	28	0	0	34	0	0	42	0	0	41	0
Delayed Vehicle Green [s]	0.0	0.0	0.0	0.0	0.0	0.0	0.0	0.0	0.0	0.0	0.0	0.0
Rest In Walk		No			No			No			No	
I1, Start-Up Lost Time [s]	2.0	2.0	0.0	2.0	2.0	0.0	2.0	2.0	0.0	2.0	2.0	0.0
I2, Clearance Lost Time [s]	2.0	2.0	0.0	2.0	2.0	0.0	2.0	2.0	0.0	2.0	2.0	0.0
Detector Location [ft]	0.0	0.0	0.0	0.0	0.0	0.0	0.0	0.0	0.0	0.0	0.0	0.0
Detector Length [ft]	20.0	20.0	0.0	0.0	0.0	0.0	20.0	20.0	0.0	20.0	20.0	0.0
I, Upstream Filtering Factor	1.00	1.00	1.00	1.00	1.00	1.00	1.00	1.00	1.00	1.00	1.00	1.00

**Phasing & Timing: Free Running (No Pattern)**

Split [s]	0	0	0	0	0	0	0	0	0	0	0	0
Lead / Lag	Lead	-	-	Lead	-	-	Lead	-	-	Lead	-	-
Minimum Green [s]	10	12	0	10	12	0	10	12	0	10	12	0
Vehicle Extension [s]	2.0	4.0	0.0	2.0	4.0	0.0	2.0	4.0	0.0	2.0	4.0	0.0
Minimum Recall	No	Yes		No	Yes		No	No		No	No	
Maximum Recall	No	No		No	No		No	No		No	No	
Pedestrian Recall	No	No		No	No		No	No		No	No	

**Exclusive Pedestrian Phase**

Pedestrian Signal Group	0
Pedestrian Walk [s]	0
Pedestrian Clearance [s]	0



**Lane Group Calculations**

Lane Group	L	C	R	L	C	R	L	C	R	L	C	R
C, Cycle Length [s]	102	102	102	102	102	102	102	102	102	102	102	102
L, Total Lost Time per Cycle [s]	4.00	4.00	4.00	4.00	4.00	4.00	4.00	4.00	4.00	4.00	4.00	4.00
l1_p, Permitted Start-Up Lost Time [s]	0.00	0.00	0.00	0.00	0.00	0.00	0.00	0.00	0.00	0.00	0.00	0.00
l2, Clearance Lost Time [s]	2.00	2.00	2.00	2.00	2.00	2.00	2.00	2.00	2.00	2.00	2.00	2.00
g_i, Effective Green Time [s]	10	32	32	9	31	31	9	31	31	13	36	36
g / C, Green / Cycle	0.10	0.31	0.31	0.09	0.31	0.31	0.09	0.31	0.31	0.13	0.35	0.35
(v / s)_i Volume / Saturation Flow Rate	0.03	0.18	0.12	0.05	0.32	0.06	0.02	0.12	0.10	0.11	0.13	0.07
s, saturation flow rate [veh/h]	3348	5127	1567	1810	5159	1586	3514	1891	1416	3514	1891	1589
c, Capacity [veh/h]	324	1597	488	168	1588	488	309	577	432	468	662	556
d1, Uniform Delay [s]	42.63	29.27	27.42	44.19	35.19	25.80	43.22	28.02	27.12	42.93	24.61	23.09
k, delay calibration	0.04	0.15	0.15	0.04	0.15	0.15	0.04	0.15	0.15	0.04	0.15	0.15
l, Upstream Filtering Factor	1.00	1.00	1.00	1.00	1.00	1.00	1.00	1.00	1.00	1.00	1.00	1.00
d2, Incremental Delay [s]	0.17	0.45	0.75	1.16	24.48	0.25	0.15	0.65	0.67	1.45	0.48	0.25
d3, Initial Queue Delay [s]	0.00	0.00	0.00	0.00	0.00	0.00	0.00	0.00	0.00	0.00	0.00	0.00
Rp, platoon ratio	1.00	1.00	1.00	1.00	1.00	1.00	1.00	1.00	1.00	1.00	1.00	1.00
PF, progression factor	1.00	1.00	1.00	1.00	1.00	1.00	1.00	1.00	1.00	1.00	1.00	1.00

**Lane Group Results**

X, volume / capacity	0.28	0.57	0.40	0.58	1.04	0.18	0.25	0.40	0.34	0.83	0.36	0.20
d, Delay for Lane Group [s/veh]	42.81	29.73	28.17	45.35	59.67	26.05	43.37	28.67	27.79	44.38	25.09	23.35
Lane Group LOS	D	C	C	D	F	C	D	C	C	D	C	C
Critical Lane Group	Yes	No	No	No	Yes	No	No	Yes	No	Yes	No	No
50th-Percentile Queue Length [veh/ln]	1.04	5.97	3.67	2.38	16.32	1.60	0.90	4.61	2.85	4.79	4.35	1.90
50th-Percentile Queue Length [ft/ln]	26.10	149.26	91.73	59.55	407.97	40.05	22.58	115.15	71.19	119.69	108.83	47.46
95th-Percentile Queue Length [veh/ln]	1.88	9.98	6.60	4.29	23.51	2.88	1.63	8.13	5.13	8.38	7.78	3.42
95th-Percentile Queue Length [ft/ln]	46.98	249.45	165.11	107.20	587.82	72.10	40.64	203.14	128.15	209.40	194.38	85.44



**Movement, Approach, & Intersection Results**

d_M, Delay for Movement [s/veh]	42.81	29.73	28.17	45.35	59.67	26.05	43.37	28.67	27.79	44.38	25.09	23.35
Movement LOS	D	C	C	D	F	C	D	C	C	D	C	C
d_A, Approach Delay [s/veh]	30.47			57.28			30.83			34.91		
Approach LOS	C			E			C			C		
d_I, Intersection Delay [s/veh]	42.94											
Intersection LOS	D											
Intersection V/C	0.658											

**Emissions**

Vehicle Miles Traveled [mph]	24.09	240.15	51.63	24.40	415.24	22.38	6.64	20.36	12.93	87.98	54.79	25.46
Stops [stops/h]	74.01	634.95	130.06	84.45	1735.47	56.79	64.02	163.28	100.95	339.44	154.32	67.30
Fuel consumption [US gal/h]	2.38	20.33	4.25	2.37	46.73	1.71	1.22	2.90	1.81	8.99	4.34	1.95
CO [g/h]	166.56	1420.80	296.74	165.38	3266.20	119.33	84.93	202.80	126.22	628.53	303.27	136.45
NOx [g/h]	32.41	276.44	57.73	32.18	635.48	23.22	16.52	39.46	24.56	122.29	59.01	26.55
VOC [g/h]	38.60	329.28	68.77	38.33	756.97	27.65	19.68	47.00	29.25	145.67	70.29	31.62

**Other Modes**

g_Walk,mi, Effective Walk Time [s]	8.0			8.0			8.0			8.0		
M_corner, Corner Circulation Area [ft <sup>2</sup> /ped]	0.00			0.00			0.00			0.00		
M_CW, Crosswalk Circulation Area [ft <sup>2</sup> /ped]	0.00			0.00			0.00			0.00		
d_p, Pedestrian Delay [s]	43.09			43.09			43.09			43.09		
I_p,int, Pedestrian LOS Score for Intersectio	3.414			3.261			2.704			2.555		
Crosswalk LOS	C			C			B			B		
s_b, Saturation Flow Rate of the bicycle lane	2000			2000			2000			2000		
c_b, Capacity of the bicycle lane [bicycles/h]	591			591			591			591		
d_b, Bicycle Delay [s]	25.22			25.21			25.28			25.21		
I_b,int, Bicycle LOS Score for Intersection	2.216			2.570			2.314			2.781		
Bicycle LOS	B			B			B			C		

**Sequence**

Ring 1	1	2	3	4	-	-	-	-	-	-	-	-	-	-	-
Ring 2	5	6	7	8	-	-	-	-	-	-	-	-	-	-	-
Ring 3	-	-	-	-	-	-	-	-	-	-	-	-	-	-	-
Ring 4	-	-	-	-	-	-	-	-	-	-	-	-	-	-	-

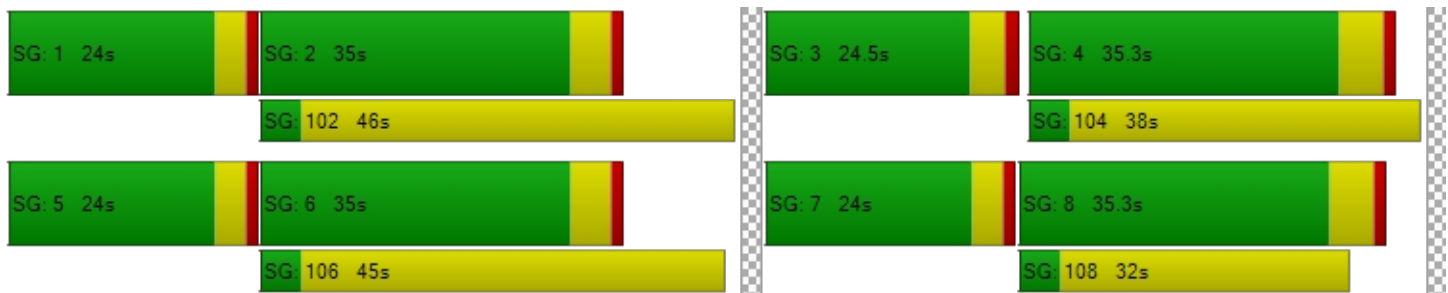

**Intersection Level Of Service Report**  
**Intersection 9: Fallon Road & Dublin Boulevard**

Control Type:	Signalized	Delay (sec / veh):	45.0
Analysis Method:	HCM 7th Edition	Level Of Service:	D
Analysis Period:	15 minutes	Volume to Capacity (v/c):	0.798

**Intersection Setup**

Name	Fallon Road			Fallon Road			Dublin Boulevard			Dublin Boulevard		
Approach	Northbound			Southbound			Eastbound			Westbound		
Lane Configuration												
Turning Movement	Left	Thru	Right	Left	Thru	Right	Left	Thru	Right	Left	Thru	Right
Lane Width [ft]	12.00	12.00	12.00	12.00	12.00	12.00	12.00	12.00	12.00	12.00	12.00	12.00
No. of Lanes in Entry Pocket	3	0	2	2	0	1	2	0	2	2	0	1
Entry Pocket Length [ft]	430.00	100.00	100.00	140.00	100.00	225.00	400.00	100.00	400.00	100.00	100.00	100.00
No. of Lanes in Exit Pocket	0	0	1	0	0	1	0	0	1	0	0	2
Exit Pocket Length [ft]	0.00	0.00	100.00	0.00	0.00	100.00	0.00	0.00	500.00	0.00	0.00	74.61
Speed [mph]	45.00			45.00			45.00			45.00		
Grade [%]	0.00			0.00			0.00			0.00		
Curb Present	Yes			Yes			Yes			Yes		
Crosswalk	No			No			Yes			Yes		



**Volumes**

Name	Fallon Road			Fallon Road			Dublin Boulevard			Dublin Boulevard		
Base Volume Input [veh/h]	267	501	912	110	1151	402	134	241	198	11	1500	243
Base Volume Adjustment Factor	1.0000	1.0000	1.0000	1.0000	1.0000	1.0000	1.0000	1.0000	1.0000	1.0000	1.0000	1.0000
Heavy Vehicles Percentage [%]	3.50	1.20	4.00	1.00	0.50	0.00	0.70	4.00	3.50	1.00	1.00	1.00
Proportion of CAVs [%]	0.00											
Growth Factor	1.0000	1.0000	1.0000	1.0000	1.0000	1.0000	1.0000	1.0000	1.0000	1.0000	1.0000	1.0000
In-Process Volume [veh/h]	0	0	0	0	0	0	0	0	0	0	0	0
Site-Generated Trips [veh/h]	0	0	0	0	0	0	0	0	0	0	0	0
Diverted Trips [veh/h]	0	0	0	0	0	0	0	0	0	0	0	0
Pass-by Trips [veh/h]	0	0	0	0	0	0	0	0	0	0	0	0
Existing Site Adjustment Volume [veh/h]	0	0	0	0	0	0	0	0	0	0	0	0
Other Volume [veh/h]	0	0	0	0	0	0	0	0	0	0	0	0
Right Turn on Red Volume [veh/h]	0	0	0	0	0	0	0	0	0	0	0	0
Total Hourly Volume [veh/h]	267	501	912	110	1151	402	134	241	198	11	1500	243
Peak Hour Factor	0.9200	0.9200	0.9400	0.9400	0.9200	0.9200	0.9200	0.9400	0.9200	0.9400	0.9400	0.9400
Other Adjustment Factor	1.0000	1.0000	1.0000	1.0000	1.0000	1.0000	1.0000	1.0000	1.0000	1.0000	1.0000	1.0000
Total 15-Minute Volume [veh/h]	73	136	243	29	313	109	36	64	54	3	399	65
Total Analysis Volume [veh/h]	290	545	970	117	1251	437	146	256	215	12	1596	259
Presence of On-Street Parking	No		No	No		No	No		No	No		No
On-Street Parking Maneuver Rate [/h]	0	0	0	0	0	0	0	0	0	0	0	0
Local Bus Stopping Rate [/h]	0	0	0	0	0	0	0	0	0	0	0	0
v_do, Outbound Pedestrian Volume crossing	0			0			0			0		
v_di, Inbound Pedestrian Volume crossing m	0			0			0			0		
v_co, Outbound Pedestrian Volume crossing	2			4			4			3		
v_ci, Inbound Pedestrian Volume crossing mi	3			4			4			2		
v_ab, Corner Pedestrian Volume [ped/h]	0			0			0			0		
Bicycle Volume [bicycles/h]	0			0			0			0		



**Intersection Settings**

Located in CBD	No
Signal Coordination Group	-
Cycle Length [s]	160
Active Pattern	Pattern 1
Coordination Type	Time of Day Pattern Isolated
Actuation Type	Fully actuated
Offset [s]	0.0
Offset Reference	Lead Green - Beginning of First Green
Permissive Mode	SingleBand
Lost time [s]	12.00

**Phasing & Timing (Basic)**

Control Type	Protecte	Permiss	Permiss	Protecte	Permiss	Permiss	Protecte	Permiss	Overlap	Protecte	Permiss	Permiss
Signal Group	3	8	0	7	4	0	5	2	2	1	6	0
Auxiliary Signal Groups									2,3			
Maximum Green [s]	30	30	0	12	30	0	30	30	30	12	12	0
Amber [s]	4.3	4.7	0.0	4.3	4.7	0.0	4.3	4.3	4.3	4.3	4.8	0.0
All red [s]	1.0	1.0	0.0	1.0	1.0	0.0	1.0	1.0	1.0	1.0	1.0	0.0
Walk [s]	0	0	0	0	4	0	0	0	0	0	0	0
Pedestrian Clearance [s]	0	0	0	0	41	0	0	0	0	0	0	0
Delayed Vehicle Green [s]	0.0	0.0	0.0	0.0	0.0	0.0	0.0	0.0	0.0	0.0	0.0	0.0
Rest In Walk		No			No			No			No	
I1, Start-Up Lost Time [s]	2.0	2.0	0.0	2.0	2.0	0.0	2.0	2.0	2.0	2.0	2.0	0.0
I2, Clearance Lost Time [s]	2.0	2.0	0.0	2.0	2.0	0.0	2.0	2.0	2.0	3.3	2.0	0.0
Detector Location [ft]	0.0	0.0	0.0	0.0	0.0	0.0	0.0	0.0	0.0	0.0	0.0	0.0
Detector Length [ft]	0.0	0.0	0.0	0.0	0.0	0.0	20.0	20.0	20.0	0.0	0.0	0.0
I, Upstream Filtering Factor	1.00	1.00	1.00	1.00	1.00	1.00	1.00	1.00	1.00	1.00	1.00	1.00

**Phasing & Timing: Pattern 1**

Split [s]	16	51	0	16	51	0	16	77	77	16	77	0
Lead / Lag	Lead	-	-	Lead	-	-	Lead	-	-	Lead	-	-
Minimum Green [s]	10	12	0	10	12	0	10	12	12	10	10	0
Vehicle Extension [s]	2.0	4.0	0.0	2.0	4.0	0.0	2.0	4.0	4.0	2.0	2.0	0.0
Minimum Recall	No	Yes		No	Yes		No	No	No	No	No	
Maximum Recall	No	No		No	No		No	No	No	No	No	
Pedestrian Recall	No	No		No	No		No	No	No	No	No	

**Exclusive Pedestrian Phase**

Pedestrian Signal Group	0
Pedestrian Walk [s]	0
Pedestrian Clearance [s]	0



**Lane Group Calculations**

Lane Group	L	C	R	L	C	R	L	C	R	L	C	R
C, Cycle Length [s]	160	160	160	160	160	160	160	160	160	160	160	160
L, Total Lost Time per Cycle [s]	4.00	4.00	4.00	4.00	4.00	4.00	4.00	4.00	4.00	5.30	4.00	4.00
l1_p, Permitted Start-Up Lost Time [s]	0.00	0.00	0.00	0.00	0.00	0.00	0.00	0.00	0.00	0.00	0.00	0.00
l2, Clearance Lost Time [s]	2.00	2.00	2.00	2.00	2.00	2.00	2.00	2.00	0.00	3.30	2.00	2.00
g_i, Effective Green Time [s]	13	67	67	11	64	64	11	61	78	4	55	55
g / C, Green / Cycle	0.08	0.42	0.42	0.07	0.40	0.40	0.07	0.38	0.49	0.03	0.34	0.34
(v / s)_i Volume / Saturation Flow Rate	0.06	0.08	0.35	0.03	0.18	0.27	0.04	0.05	0.08	0.00	0.31	0.16
s, saturation flow rate [veh/h]	5125	6835	2758	3486	6874	1605	3495	5012	2780	5230	5135	1602
c, Capacity [veh/h]	431	2849	1150	245	2770	647	247	1899	1334	135	1757	548
d1, Uniform Delay [s]	71.13	29.56	41.88	71.53	34.84	39.07	72.09	32.52	23.46	76.08	50.22	41.28
k, delay calibration	0.04	0.50	0.50	0.04	0.50	0.50	0.04	0.15	0.15	0.04	0.04	0.04
l, Upstream Filtering Factor	1.00	1.00	1.00	1.00	1.00	1.00	1.00	1.00	1.00	1.00	1.00	1.00
d2, Incremental Delay [s]	0.69	0.15	7.63	0.54	0.53	5.57	0.84	0.05	0.08	0.10	0.80	0.24
d3, Initial Queue Delay [s]	0.00	0.00	0.00	0.00	0.00	0.00	0.00	0.00	0.00	0.00	0.00	0.00
Rp, platoon ratio	1.00	1.00	1.00	1.00	1.00	1.00	1.00	1.00	1.00	1.00	1.00	1.00
PF, progression factor	1.00	1.00	1.00	1.00	1.00	1.00	1.00	1.00	1.00	1.00	1.00	1.00

**Lane Group Results**

X, volume / capacity	0.67	0.19	0.84	0.48	0.45	0.68	0.59	0.13	0.16	0.09	0.91	0.47
d, Delay for Lane Group [s/veh]	71.81	29.71	49.51	72.07	35.38	44.65	72.93	32.56	23.54	76.18	51.01	41.52
Lane Group LOS	E	C	D	E	D	D	E	C	C	E	D	D
Critical Lane Group	No	No	Yes	Yes	No	No	Yes	No	No	No	Yes	No
50th-Percentile Queue Length [veh/ln]	3.83	3.34	17.91	2.30	8.89	14.76	2.90	2.17	2.29	0.16	19.93	7.96
50th-Percentile Queue Length [ft/ln]	95.83	83.51	447.83	57.58	222.13	369.10	72.59	54.21	57.29	4.01	498.33	199.03
95th-Percentile Queue Length [veh/ln]	6.90	6.01	24.85	4.15	13.77	21.07	5.23	3.90	4.13	0.29	27.26	12.59
95th-Percentile Queue Length [ft/ln]	172.49	150.31	621.36	103.65	344.34	526.64	130.67	97.58	103.13	7.23	681.38	314.72



**Movement, Approach, & Intersection Results**

d_M, Delay for Movement [s/veh]	71.81	29.71	49.51	72.07	35.38	44.65	72.93	32.56	23.54	76.18	51.01	41.52
Movement LOS	E	C	D	E	D	D	E	C	C	E	D	D
d_A, Approach Delay [s/veh]	47.11			40.00			38.97			49.86		
Approach LOS	D			D			D			D		
d_I, Intersection Delay [s/veh]	45.02											
Intersection LOS	D											
Intersection V/C	0.798											

**Emissions**

Vehicle Miles Traveled [mph]	38.95	73.20	130.28	30.98	331.23	115.71	175.66	308.01	258.68	2.69	358.16	58.12
Stops [stops/h]	258.76	300.65	806.18	103.66	799.76	332.23	130.69	146.39	103.14	10.84	1345.63	179.15
Fuel consumption [US gal/h]	8.79	9.54	24.26	4.07	30.30	12.07	9.81	14.07	11.18	0.41	45.57	6.41
CO [g/h]	614.41	666.99	1695.79	284.24	2118.16	843.48	685.90	983.78	781.41	28.87	3185.68	447.90
NOx [g/h]	119.54	129.77	329.94	55.30	412.12	164.11	133.45	191.41	152.03	5.62	619.82	87.14
VOC [g/h]	142.40	154.58	393.02	65.88	490.91	195.49	158.96	228.00	181.10	6.69	738.31	103.80

**Other Modes**

g_Walk,mi, Effective Walk Time [s]	0.0			0.0			8.0			45.3		
M_corner, Corner Circulation Area [ft <sup>2</sup> /ped]	0.00			0.00			0.00			0.00		
M_CW, Crosswalk Circulation Area [ft <sup>2</sup> /ped]	0.00			0.00			57.54			0.00		
d_p, Pedestrian Delay [s]	0.00			0.00			72.19			41.10		
I_p,int, Pedestrian LOS Score for Intersectio	0.000			0.000			3.425			3.511		
Crosswalk LOS	F			F			C			D		
s_b, Saturation Flow Rate of the bicycle lane	2000			2000			2000			2000		
c_b, Capacity of the bicycle lane [bicycles/h]	566			566			896			890		
d_b, Bicycle Delay [s]	41.10			41.10			24.36			24.63		
I_b,int, Bicycle LOS Score for Intersection	2.304			2.304			1.899			2.586		
Bicycle LOS	B			B			A			B		

**Sequence**

Ring 1	1	2	3	4	-	-	-	-	-	-	-	-	-	-	-
Ring 2	5	6	7	8	-	-	-	-	-	-	-	-	-	-	-
Ring 3	-	-	-	-	-	-	-	-	-	-	-	-	-	-	-
Ring 4	-	-	-	-	-	-	-	-	-	-	-	-	-	-	-

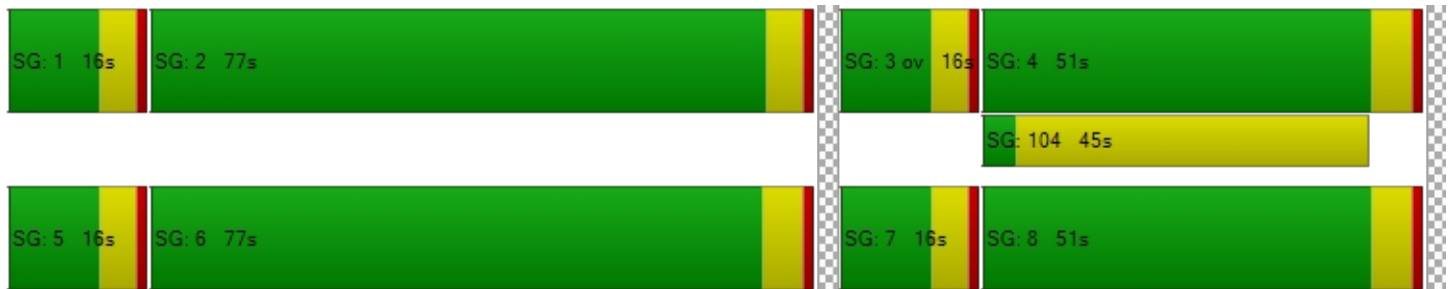



**Intersection Level Of Service Report**  
**Intersection 10: Fallon Road & Fallon Gateway**

Control Type:	Signalized	Delay (sec / veh):	15.8
Analysis Method:	HCM 7th Edition	Level Of Service:	B
Analysis Period:	15 minutes	Volume to Capacity (v/c):	0.429

**Intersection Setup**

Name	Fallon Road			Fallon Road			Fallon Gateway			PacVest		
Approach	Northbound			Southbound			Eastbound			Westbound		
Lane Configuration	[Diagram]			[Diagram]			[Diagram]			[Diagram]		
Turning Movement	Left	Thru	Right	Left	Thru	Right	Left	Thru	Right	Left	Thru	Right
Lane Width [ft]	12.00	12.00	12.00	12.00	12.00	12.00	12.00	12.00	12.00	12.00	12.00	12.00
No. of Lanes in Entry Pocket	1	0	1	1	0	1	1	0	1	1	0	1
Entry Pocket Length [ft]	275.00	100.00	100.00	100.00	100.00	100.00	210.00	100.00	210.00	100.00	100.00	100.00
No. of Lanes in Exit Pocket	0	0	2	0	0	0	0	0	0	0	0	0
Exit Pocket Length [ft]	0.00	0.00	100.00	0.00	0.00	0.00	0.00	0.00	0.00	0.00	0.00	0.00
Speed [mph]	45.00			40.00			25.00			30.00		
Grade [%]	0.00			0.00			0.00			0.00		
Curb Present	Yes			Yes			Yes			No		
Crosswalk	No			No			Yes			Yes		



**Volumes**

Name	Fallon Road			Fallon Road			Fallon Gateway			PacVest		
Base Volume Input [veh/h]	186	1523	273	91	1178	42	20	2	94	71	2	33
Base Volume Adjustment Factor	1.0000	1.0000	1.0000	1.0000	1.0000	1.0000	1.0000	1.0000	1.0000	1.0000	1.0000	1.0000
Heavy Vehicles Percentage [%]	1.70	4.10	2.00	2.00	1.00	0.00	0.00	2.00	4.30	2.00	2.00	2.00
Proportion of CAVs [%]	0.00											
Growth Factor	1.0000	1.0000	1.0000	1.0000	1.0000	1.0000	1.0000	1.0000	1.0000	1.0000	1.0000	1.0000
In-Process Volume [veh/h]	0	0	0	0	0	0	0	0	0	0	0	0
Site-Generated Trips [veh/h]	0	0	0	0	0	0	0	0	0	0	0	0
Diverted Trips [veh/h]	0	0	0	0	0	0	0	0	0	0	0	0
Pass-by Trips [veh/h]	0	0	0	0	0	0	0	0	0	0	0	0
Existing Site Adjustment Volume [veh/h]	0	0	0	0	0	0	0	0	0	0	0	0
Other Volume [veh/h]	0	0	0	0	0	0	0	0	0	0	0	0
Right Turn on Red Volume [veh/h]	0	0	0	0	0	0	0	0	0	0	0	0
Total Hourly Volume [veh/h]	186	1523	273	91	1178	42	20	2	94	71	2	33
Peak Hour Factor	0.9000	0.9000	1.0000	1.0000	0.9000	0.9000	0.9000	1.0000	0.9000	1.0000	1.0000	1.0000
Other Adjustment Factor	1.0000	1.0000	1.0000	1.0000	1.0000	1.0000	1.0000	1.0000	1.0000	1.0000	1.0000	1.0000
Total 15-Minute Volume [veh/h]	52	423	68	23	327	12	6	1	26	18	1	8
Total Analysis Volume [veh/h]	207	1692	273	91	1309	47	22	2	104	71	2	33
Presence of On-Street Parking	No		No	No		No	No		No	No		No
On-Street Parking Maneuver Rate [/h]	0	0	0	0	0	0	0	0	0	0	0	0
Local Bus Stopping Rate [/h]	0	0	0	0	0	0	0	0	0	0	0	0
v_do, Outbound Pedestrian Volume crossing	0			0			0			0		
v_di, Inbound Pedestrian Volume crossing m	0			0			0			0		
v_co, Outbound Pedestrian Volume crossing	0			0			0			0		
v_ci, Inbound Pedestrian Volume crossing mi	0			0			0			0		
v_ab, Corner Pedestrian Volume [ped/h]	0			0			0			0		
Bicycle Volume [bicycles/h]	0			0			0			0		



**Intersection Settings**

Located in CBD	No
Signal Coordination Group	-
Cycle Length [s]	240
Active Pattern	Pattern 1
Coordination Type	Time of Day Pattern Isolated
Actuation Type	Fully actuated
Offset [s]	0.0
Offset Reference	Lead Green - Beginning of First Green
Permissive Mode	SingleBand
Lost time [s]	12.00

**Phasing & Timing (Basic)**

Control Type	Protecte	Permiss	Permiss	Protecte	Permiss	Permiss	Protecte	Permiss	Permiss	Protecte	Permiss	Permiss
Signal Group	3	8	0	7	4	0	5	2	2	1	6	0
Auxiliary Signal Groups												
Maximum Green [s]	20	40	0	5	40	0	5	30	30	5	10	0
Amber [s]	3.5	4.7	0.0	3.0	4.7	0.0	3.0	3.5	3.5	3.0	3.0	0.0
All red [s]	1.0	1.0	0.0	1.0	1.0	0.0	1.0	1.0	1.0	1.0	1.0	0.0
Walk [s]	0	0	0	0	4	0	0	0	0	0	5	0
Pedestrian Clearance [s]	0	0	0	0	28	0	0	0	0	0	10	0
Delayed Vehicle Green [s]	0.0	0.0	0.0	0.0	0.0	0.0	0.0	0.0	0.0	0.0	0.0	0.0
Rest In Walk		No			No			No			No	
I1, Start-Up Lost Time [s]	2.0	2.0	0.0	2.0	2.0	0.0	2.0	2.0	2.0	2.0	2.0	0.0
I2, Clearance Lost Time [s]	2.5	3.7	0.0	2.0	3.7	0.0	2.0	2.5	2.5	2.0	2.0	0.0
Detector Location [ft]	0.0	0.0	0.0	0.0	0.0	0.0	0.0	0.0	0.0	0.0	0.0	0.0
Detector Length [ft]	0.0	0.0	0.0	0.0	0.0	0.0	20.0	20.0	20.0	20.0	20.0	0.0
I, Upstream Filtering Factor	1.00	1.00	1.00	1.00	1.00	1.00	1.00	1.00	1.00	1.00	1.00	1.00

**Phasing & Timing: Pattern 1**

Split [s]	86	179	0	27	120	0	10	20	20	14	24	0
Lead / Lag	Lead	-	-	Lead	-	-	Lead	-	-	Lead	-	-
Minimum Green [s]	10	10	0	5	10	0	5	10	10	5	10	0
Vehicle Extension [s]	2.0	5.0	0.0	3.0	5.0	0.0	3.0	2.0	2.0	3.0	3.0	0.0
Minimum Recall	No	Yes		No	Yes		No	No		No	No	
Maximum Recall	No	No		No	No		No	No		No	No	
Pedestrian Recall	No	No		No	No		No	No		No	No	

**Exclusive Pedestrian Phase**

Pedestrian Signal Group	0
Pedestrian Walk [s]	0
Pedestrian Clearance [s]	0



**Lane Group Calculations**

Lane Group	L	C	R	L	C	R	L	C	R	L	C	R
C, Cycle Length [s]	73	73	73	73	73	73	73	73	73	73	73	73
L, Total Lost Time per Cycle [s]	4.50	5.70	5.70	4.00	5.70	5.70	4.00	4.50	4.50	4.00	4.00	4.00
l1_p, Permitted Start-Up Lost Time [s]	0.00	0.00	0.00	0.00	0.00	0.00	0.00	0.00	0.00	0.00	0.00	0.00
l2, Clearance Lost Time [s]	2.50	3.70	3.70	2.00	3.70	3.70	2.00	2.50	2.50	2.00	2.00	2.00
g_i, Effective Green Time [s]	10	38	38	5	32	32	2	9	9	4	11	11
g / C, Green / Cycle	0.13	0.51	0.51	0.07	0.44	0.44	0.03	0.12	0.12	0.05	0.16	0.16
(v / s)_i Volume / Saturation Flow Rate	0.06	0.25	0.17	0.05	0.19	0.03	0.01	0.03	0.03	0.02	0.00	0.02
s, saturation flow rate [veh/h]	3467	6677	1589	1781	6846	1615	3514	1598	1560	3459	1870	1589
c, Capacity [veh/h]	468	3414	813	118	2984	704	89	195	191	182	292	249
d1, Uniform Delay [s]	29.26	11.76	10.60	33.77	14.46	12.05	35.14	29.30	29.30	33.68	26.19	26.71
k, delay calibration	0.04	0.23	0.23	0.14	0.23	0.23	0.11	0.04	0.04	0.11	0.11	0.11
l, Upstream Filtering Factor	1.00	1.00	1.00	1.00	1.00	1.00	1.00	1.00	1.00	1.00	1.00	1.00
d2, Incremental Delay [s]	0.25	0.24	0.52	12.51	0.22	0.08	1.43	0.28	0.29	1.36	0.01	0.24
d3, Initial Queue Delay [s]	0.00	0.00	0.00	0.00	0.00	0.00	0.00	0.00	0.00	0.00	0.00	0.00
Rp, platoon ratio	1.00	1.00	1.00	1.00	1.00	1.00	1.00	1.00	1.00	1.00	1.00	1.00
PF, progression factor	1.00	1.00	1.00	1.00	1.00	1.00	1.00	1.00	1.00	1.00	1.00	1.00

**Lane Group Results**

X, volume / capacity	0.44	0.50	0.34	0.77	0.44	0.07	0.25	0.27	0.27	0.39	0.01	0.13
d, Delay for Lane Group [s/veh]	29.50	12.00	11.12	46.28	14.68	12.13	36.57	29.58	29.59	35.04	26.20	26.95
Lane Group LOS	C	B	B	D	B	B	D	C	C	D	C	C
Critical Lane Group	No	Yes	No	Yes	No	No	No	No	Yes	Yes	No	No
50th-Percentile Queue Length [veh/ln]	1.56	3.67	2.22	1.91	3.34	0.41	0.21	0.86	0.84	0.63	0.03	0.50
50th-Percentile Queue Length [ft/ln]	39.07	91.80	55.50	47.86	83.55	10.27	5.20	21.48	21.04	15.73	0.73	12.47
95th-Percentile Queue Length [veh/ln]	2.81	6.61	4.00	3.45	6.02	0.74	0.37	1.55	1.51	1.13	0.05	0.90
95th-Percentile Queue Length [ft/ln]	70.33	165.24	99.90	86.14	150.39	18.49	9.36	38.67	37.87	28.31	1.32	22.44



**Movement, Approach, & Intersection Results**

d_M, Delay for Movement [s/veh]	29.50	12.00	11.12	46.28	14.68	12.13	36.57	29.58	29.59	35.04	26.20	26.95
Movement LOS	C	B	B	D	B	B	D	C	C	D	C	C
d_A, Approach Delay [s/veh]	13.56			16.58			30.79			32.35		
Approach LOS	B			B			C			C		
d_I, Intersection Delay [s/veh]	15.78											
Intersection LOS	B											
Intersection V/C	0.429											

**Emissions**

Vehicle Miles Traveled [mph]	31.49	257.43	41.54	12.22	175.81	6.31	1.35	3.29	3.22	1.68	0.05	0.78
Stops [stops/h]	153.49	721.25	109.01	93.99	656.43	20.18	20.43	42.19	41.32	61.79	1.44	24.48
Fuel consumption [US gal/h]	4.23	21.92	3.40	2.22	16.66	0.54	0.30	0.63	0.62	0.92	0.02	0.35
CO [g/h]	295.73	1532.44	237.44	155.05	1164.29	37.77	21.17	44.18	43.26	64.10	1.44	24.36
NOx [g/h]	57.54	298.16	46.20	30.17	226.53	7.35	4.12	8.60	8.42	12.47	0.28	4.74
VOC [g/h]	68.54	355.16	55.03	35.93	269.83	8.75	4.91	10.24	10.03	14.86	0.33	5.65

**Other Modes**

g_Walk,mi, Effective Walk Time [s]	0.0			0.0			8.0			173.3		
M_corner, Corner Circulation Area [ft <sup>2</sup> /ped]	0.00			0.00			0.00			0.00		
M_CW, Crosswalk Circulation Area [ft <sup>2</sup> /ped]	0.00			0.00			0.00			0.00		
d_p, Pedestrian Delay [s]	0.00			0.00			29.09			68.18		
I_p,int, Pedestrian LOS Score for Intersectio	0.000			0.000			2.497			2.419		
Crosswalk LOS	F			F			B			B		
s_b, Saturation Flow Rate of the bicycle lane	2000			2000			2000			2000		
c_b, Capacity of the bicycle lane [bicycles/h]	4728			3118			423			546		
d_b, Bicycle Delay [s]	68.18			11.46			22.80			19.39		
I_b,int, Bicycle LOS Score for Intersection	2.456			2.156			1.771			1.735		
Bicycle LOS	B			B			A			A		

**Sequence**

Ring 1	1	2	3	4	-	-	-	-	-	-	-	-	-	-	-
Ring 2	5	6	7	8	-	-	-	-	-	-	-	-	-	-	-
Ring 3	-	-	-	-	-	-	-	-	-	-	-	-	-	-	-
Ring 4	-	-	-	-	-	-	-	-	-	-	-	-	-	-	-

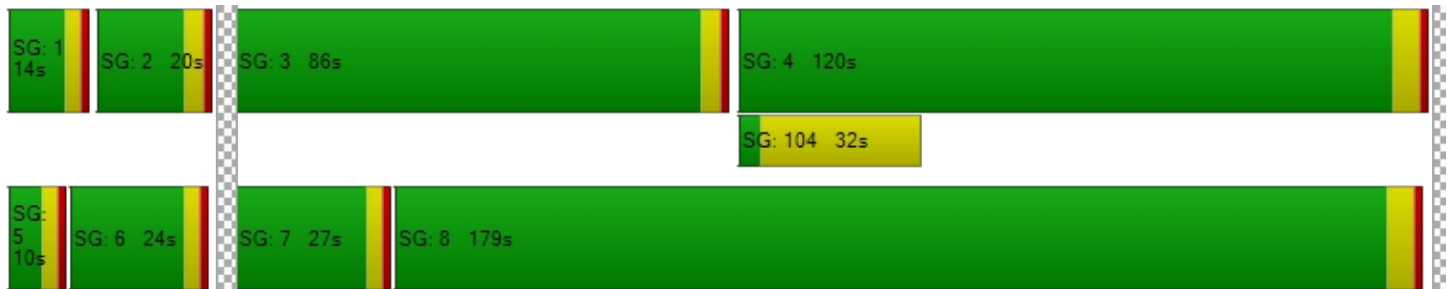

**Intersection Level Of Service Report**  
**Intersection 11: Fallon Road & I-580 WB Ramps**

Control Type:	Signalized	Delay (sec / veh):	179.5
Analysis Method:	HCM 7th Edition	Level Of Service:	F
Analysis Period:	15 minutes	Volume to Capacity (v/c):	1.061

**Intersection Setup**

Name	Fallon Road			Fallon Road			I-580 WB On-Ramp			I-580 WB Off-Ramp		
Approach	Northbound			Southbound			Eastbound			Westbound		
Lane Configuration	↑			↑↑↑						↑↑↑↑		
Turning Movement	Left	Thru	Right	Left	Thru	Right	Left	Thru	Right	Left	Thru	Right
Lane Width [ft]	12.00	12.00	12.00	12.00	12.00	12.00	12.00	12.00	12.00	12.00	12.00	12.00
No. of Lanes in Entry Pocket	0	0	0	0	0	1	0	0	0	1	0	1
Entry Pocket Length [ft]	100.00	100.00	100.00	100.00	100.00	225.00	100.00	100.00	100.00	170.00	100.00	130.00
No. of Lanes in Exit Pocket	0	0	1	0	0	0	0	0	1	0	0	0
Exit Pocket Length [ft]	0.00	0.00	400.00	0.00	0.00	0.00	0.00	0.00	400.00	0.00	0.00	0.00
Speed [mph]	45.00			40.00			30.00			35.00		
Grade [%]	0.00			0.00			0.00			0.00		
Curb Present	No			No						No		
Crosswalk	No			No			No			No		



**Volumes**

Name	Fallon Road			Fallon Road			I-580 WB On-Ramp			I-580 WB Off-Ramp		
Base Volume Input [veh/h]	0	1606	0	0	732	683	0	0	0	236	7	471
Base Volume Adjustment Factor	1.0000	1.0000	1.0000	1.0000	1.0000	1.0000	1.0000	1.0000	1.0000	1.0000	1.0000	1.0000
Heavy Vehicles Percentage [%]	2.00	0.60	2.00	2.00	1.90	0.40	2.00	2.00	2.00	4.20	0.00	4.00
Proportion of CAVs [%]	0.00											
Growth Factor	1.0000	1.0000	1.0000	1.0000	1.0000	1.0000	1.0000	1.0000	1.0000	1.0000	1.0000	1.0000
In-Process Volume [veh/h]	0	0	0	0	0	0	0	0	0	0	0	0
Site-Generated Trips [veh/h]	0	0	0	0	0	0	0	0	0	0	0	0
Diverted Trips [veh/h]	0	0	0	0	0	0	0	0	0	0	0	0
Pass-by Trips [veh/h]	0	0	0	0	0	0	0	0	0	0	0	0
Existing Site Adjustment Volume [veh/h]	0	0	0	0	0	0	0	0	0	0	0	0
Other Volume [veh/h]	0	0	0	0	0	0	0	0	0	0	0	0
Right Turn on Red Volume [veh/h]	0	0	0	0	0	0	0	0	0	0	0	0
Total Hourly Volume [veh/h]	0	1606	0	0	732	683	0	0	0	236	7	471
Peak Hour Factor	1.0000	0.9500	1.0000	1.0000	0.9500	0.9500	1.0000	1.0000	1.0000	0.9500	0.9500	0.9500
Other Adjustment Factor	1.0000	1.0000	1.0000	1.0000	1.0000	1.0000	1.0000	1.0000	1.0000	1.0000	1.0000	1.0000
Total 15-Minute Volume [veh/h]	0	423	0	0	193	180	0	0	0	62	2	124
Total Analysis Volume [veh/h]	0	1691	0	0	771	719	0	0	0	248	7	496
Presence of On-Street Parking	No		No	No		No				No		No
On-Street Parking Maneuver Rate [/h]	0	0	0	0	0	0	0	0	0	0	0	0
Local Bus Stopping Rate [/h]	0	0	0	0	0	0	0	0	0	0	0	0
v_do, Outbound Pedestrian Volume crossing	0			0			0			0		
v_di, Inbound Pedestrian Volume crossing m	0			0			0			0		
v_co, Outbound Pedestrian Volume crossing	0			0			0			0		
v_ci, Inbound Pedestrian Volume crossing mi	0			0			0			0		
v_ab, Corner Pedestrian Volume [ped/h]	0			0			0			0		
Bicycle Volume [bicycles/h]	0			0			0			0		



**Intersection Settings**

Located in CBD	No
Signal Coordination Group	-
Cycle Length [s]	90
Active Pattern	Free Running (No Pattern)
Coordination Type	<i>Free Running</i>
Actuation Type	<i>Fully actuated</i>
Offset [s]	0.0
Offset Reference	Lead Green - Beginning of First Green
Permissive Mode	SingleBand
Lost time [s]	9.00

**Phasing & Timing (Basic)**

Control Type	Permiss	Permiss	Permiss	Permiss	Permiss	Permiss	Permiss	Permiss	Permiss	Permiss	Permiss	Overlap
Signal Group	0	2	0	0	6	0	0	0	0	0	8	1
Auxiliary Signal Groups												1,8
Maximum Green [s]	0	35	0	0	35	0	0	0	0	0	20	15
Amber [s]	0.0	4.8	0.0	0.0	4.8	0.0	0.0	0.0	0.0	0.0	3.7	3.7
All red [s]	0.0	0.5	0.0	0.0	0.5	0.0	0.0	0.0	0.0	0.0	0.5	0.5
Walk [s]	0	0	0	0	0	0	0	0	0	0	0	0
Pedestrian Clearance [s]	0	0	0	0	0	0	0	0	0	0	0	0
Delayed Vehicle Green [s]	0.0	0.0	0.0	0.0	0.0	0.0	0.0	0.0	0.0	0.0	0.0	0.0
Rest In Walk		No			No						No	
I1, Start-Up Lost Time [s]	0.0	2.0	0.0	0.0	2.0	0.0	0.0	0.0	0.0	0.0	2.0	2.0
I2, Clearance Lost Time [s]	0.0	3.3	0.0	0.0	3.3	0.0	0.0	0.0	0.0	0.0	2.2	2.2
Detector Location [ft]	0.0	0.0	0.0	0.0	0.0	0.0	0.0	0.0	0.0	0.0	0.0	0.0
Detector Length [ft]	0.0	20.0	0.0	0.0	20.0	0.0	0.0	0.0	0.0	0.0	20.0	20.0
I, Upstream Filtering Factor	1.00	1.00	1.00	1.00	1.00	1.00	1.00	1.00	1.00	1.00	1.00	1.00

**Phasing & Timing: Free Running (No Pattern)**

Split [s]	0	0	0	0	0	0	0	0	0	0	0	0
Lead / Lag	-	-	-	-	-	-	-	-	-	-	-	-
Minimum Green [s]	0	10	0	0	10	0	0	0	0	0	5	4
Vehicle Extension [s]	0.0	0.0	0.0	0.0	0.0	0.0	0.0	0.0	0.0	0.0	0.0	0.0
Minimum Recall		Yes			Yes						No	No
Maximum Recall		No			No						No	No
Pedestrian Recall		No			No						No	No

**Exclusive Pedestrian Phase**

Pedestrian Signal Group	0
Pedestrian Walk [s]	0
Pedestrian Clearance [s]	0





**Lane Group Calculations**

Lane Group	C	C	R		L	C	R
C, Cycle Length [s]	72	72	72		72	72	72
L, Total Lost Time per Cycle [s]	5.30	5.30	5.30		4.20	4.20	4.20
l1_p, Permitted Start-Up Lost Time [s]	0.00	0.00	0.00		0.00	0.00	0.00
l2, Clearance Lost Time [s]	3.30	3.30	3.30		2.20	2.20	0.00
g_i, Effective Green Time [s]	35	51	51		12	12	28
g / C, Green / Cycle	0.48	0.71	0.71		0.16	0.16	0.38
(v / s)_i Volume / Saturation Flow Rate	0.89	0.22	0.45		0.07	0.07	0.18
s, saturation flow rate [veh/h]	1891	3563	1610		1749	1814	2768
c, Capacity [veh/h]	916	2513	1135		285	296	1063
d1, Uniform Delay [s]	18.61	4.00	5.67		27.24	27.24	16.70
k, delay calibration	0.50	0.04	0.35		0.04	0.04	0.04
l, Upstream Filtering Factor	1.00	1.00	1.00		1.00	1.00	1.00
d2, Incremental Delay [s]	384.69	0.03	1.92		0.39	0.38	0.12
d3, Initial Queue Delay [s]	0.00	0.00	0.00		0.00	0.00	0.00
Rp, platoon ratio	1.00	1.00	1.00		1.00	1.00	1.00
PF, progression factor	1.00	1.00	1.00		1.00	1.00	1.00

**Lane Group Results**

X, volume / capacity	1.85	0.31	0.63		0.44	0.44	0.47
d, Delay for Lane Group [s/veh]	403.30	4.03	7.59		27.63	27.62	16.82
Lane Group LOS	F	A	A		C	C	B
Critical Lane Group	Yes	No	No		No	No	Yes
50th-Percentile Queue Length [veh/ln]	109.94	1.27	3.94		1.88	1.94	2.81
50th-Percentile Queue Length [ft/ln]	2748.49	31.78	98.49		46.90	48.56	70.31
95th-Percentile Queue Length [veh/ln]	174.85	2.29	7.09		3.38	3.50	5.06
95th-Percentile Queue Length [ft/ln]	4371.17	57.20	177.28		84.41	87.41	126.56

**Movement, Approach, & Intersection Results**

d_M, Delay for Movement [s/veh]	0.00	403.30	0.00	0.00	4.03	7.59	0.00	0.00	0.00	27.63	27.62	16.82
Movement LOS		F			A	A				C	C	B
d_A, Approach Delay [s/veh]	403.30		5.75			0.00			20.49			
Approach LOS	F		A			A			C			
d_I, Intersection Delay [s/veh]	179.53											
Intersection LOS	F											
Intersection V/C	1.061											

**Emissions**

Vehicle Miles Traveled [mph]	176.24	117.30	109.39	18.17	18.83	71.95
Stops [stops/h]	5482.95	126.79	196.47	93.55	96.88	280.52
Fuel consumption [US gal/h]	212.97	6.08	6.96	2.10	2.18	6.55
CO [g/h]	14886.54	424.96	486.43	146.81	152.07	457.85
NOx [g/h]	2896.38	82.68	94.64	28.56	29.59	89.08
VOC [g/h]	3450.10	98.49	112.73	34.03	35.24	106.11

**Other Modes**

g_Walk,mi, Effective Walk Time [s]	0.0	0.0	0.0	0.0
M_corner, Corner Circulation Area [ft <sup>2</sup> /ped]	0.00	0.00	0.00	0.00
M_CW, Crosswalk Circulation Area [ft <sup>2</sup> /ped]	0.00	0.00	0.00	0.00
d_p, Pedestrian Delay [s]	0.00	0.00	0.00	0.00
I_p,int, Pedestrian LOS Score for Intersectio	0.000	0.000	0.000	0.000
Crosswalk LOS	F	F	F	F
s_b, Saturation Flow Rate of the bicycle lane	2000	2000	2000	2000
c_b, Capacity of the bicycle lane [bicycles/h]	970	970	0	554
d_b, Bicycle Delay [s]	9.58	9.58	36.09	18.86
I_b,int, Bicycle LOS Score for Intersection	4.350	2.789	4.132	2.799
Bicycle LOS	E	C	D	C

**Sequence**

Ring 1	1	2	-	-	-	-	-	-	-	-	-	-	-	-	-
Ring 2	-	6	-	8	-	-	-	-	-	-	-	-	-	-	-
Ring 3	-	-	-	-	-	-	-	-	-	-	-	-	-	-	-
Ring 4	-	-	-	-	-	-	-	-	-	-	-	-	-	-	-



**Intersection Level Of Service Report**  
**Intersection 12: El Charro Road & I-580 EB Ramps**

Control Type:	Signalized	Delay (sec / veh):	10.1
Analysis Method:	HCM 7th Edition	Level Of Service:	B
Analysis Period:	15 minutes	Volume to Capacity (v/c):	0.843

**Intersection Setup**

Name	El Charro Road			Fallon Road			I-580 EB Off-Ramp			I-580 EB On-Ramp		
Approach	Northbound			Southbound			Eastbound			Westbound		
Lane Configuration	↑↑			↑↑			↵↵↵↵					
Turning Movement	Left	Thru	Right	Left	Thru	Right	Left	Thru	Right	Left	Thru	Right
Lane Width [ft]	12.00	12.00	12.00	12.00	12.00	12.00	12.00	12.00	12.00	12.00	12.00	12.00
No. of Lanes in Entry Pocket	0	0	0	1	0	0	1	0	1	0	0	0
Entry Pocket Length [ft]	100.00	100.00	100.00	135.00	100.00	100.00	350.00	100.00	350.00	100.00	100.00	100.00
No. of Lanes in Exit Pocket	0	0	0	0	0	1	0	0	0	0	0	0
Exit Pocket Length [ft]	0.00	0.00	0.00	0.00	0.00	100.00	0.00	0.00	0.00	0.00	0.00	0.00
Speed [mph]	30.00			40.00			35.00			30.00		
Grade [%]	0.00			0.00			0.00			0.00		
Curb Present	No			No			No					
Crosswalk	No			No			No			Yes		



**Volumes**

Name	El Charro Road			Fallon Road			I-580 EB Off-Ramp			I-580 EB On-Ramp		
Base Volume Input [veh/h]	0	1160	0	0	557	0	790	0	366	0	0	0
Base Volume Adjustment Factor	1.0000	1.0000	1.0000	1.0000	1.0000	1.0000	1.0000	1.0000	1.0000	1.0000	1.0000	1.0000
Heavy Vehicles Percentage [%]	2.00	10.40	2.00	2.00	2.70	2.00	0.90	2.00	10.60	2.00	2.00	2.00
Proportion of CAVs [%]	0.00											
Growth Factor	1.0000	1.0000	1.0000	1.0000	1.0000	1.0000	1.0000	1.0000	1.0000	1.0000	1.0000	1.0000
In-Process Volume [veh/h]	0	0	0	0	0	0	0	0	0	0	0	0
Site-Generated Trips [veh/h]	0	0	0	0	0	0	0	0	0	0	0	0
Diverted Trips [veh/h]	0	0	0	0	0	0	0	0	0	0	0	0
Pass-by Trips [veh/h]	0	0	0	0	0	0	0	0	0	0	0	0
Existing Site Adjustment Volume [veh/h]	0	0	0	0	0	0	0	0	0	0	0	0
Other Volume [veh/h]	0	0	0	0	0	0	0	0	0	0	0	0
Right Turn on Red Volume [veh/h]	0	0	0	0	0	0	0	0	0	0	0	0
Total Hourly Volume [veh/h]	0	1160	0	0	557	0	790	0	366	0	0	0
Peak Hour Factor	1.0000	0.9300	1.0000	1.0000	0.9300	1.0000	0.9300	1.0000	0.9300	1.0000	1.0000	1.0000
Other Adjustment Factor	1.0000	1.0000	1.0000	1.0000	1.0000	1.0000	1.0000	1.0000	1.0000	1.0000	1.0000	1.0000
Total 15-Minute Volume [veh/h]	0	312	0	0	150	0	212	0	98	0	0	0
Total Analysis Volume [veh/h]	0	1247	0	0	599	0	849	0	394	0	0	0
Presence of On-Street Parking	No		No	No		No	No		No			
On-Street Parking Maneuver Rate [/h]	0	0	0	0	0	0	0	0	0	0	0	0
Local Bus Stopping Rate [/h]	0	0	0	0	0	0	0	0	0	0	0	0
v_do, Outbound Pedestrian Volume crossing	0			0			0			0		
v_di, Inbound Pedestrian Volume crossing m	0			0			0			0		
v_co, Outbound Pedestrian Volume crossing	0			0			0			0		
v_ci, Inbound Pedestrian Volume crossing mi	0			0			0			0		
v_ab, Corner Pedestrian Volume [ped/h]	0			0			0			0		
Bicycle Volume [bicycles/h]	0			0			0			0		



**Intersection Settings**

Located in CBD	No
Signal Coordination Group	-
Cycle Length [s]	90
Active Pattern	Free Running (No Pattern)
Coordination Type	<i>Free Running</i>
Actuation Type	<i>Fully actuated</i>
Offset [s]	0.0
Offset Reference	Lead Green - Beginning of First Green
Permissive Mode	SingleBand
Lost time [s]	9.00

**Phasing & Timing (Basic)**

Control Type	Permiss	Permiss	Permiss	Permiss	Permiss	Permiss	Permiss	Permiss	Permiss	Permiss	Permiss	Permiss
Signal Group	0	2	0	0	6	0	4	0	0	0	0	0
Auxiliary Signal Groups												
Maximum Green [s]	0	40	0	0	40	0	26	0	0	0	0	0
Amber [s]	0.0	4.8	0.0	0.0	4.8	0.0	3.7	0.0	0.0	0.0	0.0	0.0
All red [s]	0.0	1.0	0.0	0.0	1.0	0.0	0.5	0.0	0.0	0.0	0.0	0.0
Walk [s]	0	0	0	0	0	0	0	0	0	0	0	0
Pedestrian Clearance [s]	0	0	0	0	0	0	0	0	0	0	0	0
Delayed Vehicle Green [s]	0.0	0.0	0.0	0.0	0.0	0.0	0.0	0.0	0.0	0.0	0.0	0.0
Rest In Walk		No			No		No					
I1, Start-Up Lost Time [s]	0.0	2.0	0.0	0.0	2.0	0.0	2.0	0.0	0.0	0.0	0.0	0.0
I2, Clearance Lost Time [s]	0.0	3.3	0.0	0.0	3.3	0.0	2.7	0.0	0.0	0.0	0.0	0.0
Detector Location [ft]	0.0	0.0	0.0	0.0	0.0	0.0	0.0	0.0	0.0	0.0	0.0	0.0
Detector Length [ft]	0.0	20.0	0.0	0.0	20.0	0.0	20.0	0.0	0.0	0.0	0.0	0.0
I, Upstream Filtering Factor	1.00	1.00	1.00	1.00	1.00	1.00	1.00	1.00	1.00	1.00	1.00	1.00

**Phasing & Timing: Free Running (No Pattern)**

Split [s]	0	0	0	0	0	0	0	0	0	0	0	0
Lead / Lag	-	-	-	-	-	-	Lead	-	-	-	-	-
Minimum Green [s]	0	10	0	0	10	0	4	0	0	0	0	0
Vehicle Extension [s]	0.0	0.0	0.0	0.0	0.0	0.0	0.0	0.0	0.0	0.0	0.0	0.0
Minimum Recall		Yes			Yes		No					
Maximum Recall		No			No		No					
Pedestrian Recall		No			No		No					

**Exclusive Pedestrian Phase**

Pedestrian Signal Group	0
Pedestrian Walk [s]	0
Pedestrian Clearance [s]	0



**Lane Group Calculations**

Lane Group	C	C	L	R	
C, Cycle Length [s]	34	34	34	34	
L, Total Lost Time per Cycle [s]	5.30	5.30	4.70	4.70	
l1_p, Permitted Start-Up Lost Time [s]	0.00	0.00	0.00	0.00	
l2, Clearance Lost Time [s]	3.30	3.30	2.70	2.70	
g_i, Effective Green Time [s]	14	14	9	9	
g / C, Green / Cycle	0.42	0.42	0.28	0.28	
(v / s)_i Volume / Saturation Flow Rate	0.38	0.17	0.24	0.15	
s, saturation flow rate [veh/h]	3320	3540	3489	2619	
c, Capacity [veh/h]	1410	1503	980	736	
d1, Uniform Delay [s]	9.00	6.77	11.60	10.33	
k, delay calibration	0.04	0.04	0.04	0.04	
l, Upstream Filtering Factor	1.00	1.00	1.00	1.00	
d2, Incremental Delay [s]	0.77	0.06	0.94	0.23	
d3, Initial Queue Delay [s]	0.00	0.00	0.00	0.00	
Rp, platoon ratio	1.00	1.00	1.00	1.00	
PF, progression factor	1.00	1.00	1.00	1.00	

**Lane Group Results**

X, volume / capacity	0.88	0.40	0.87	0.54	
d, Delay for Lane Group [s/veh]	9.77	6.83	12.54	10.56	
Lane Group LOS	A	A	B	B	
Critical Lane Group	Yes	No	Yes	No	
50th-Percentile Queue Length [veh/ln]	2.67	0.76	2.17	0.87	
50th-Percentile Queue Length [ft/ln]	66.85	19.02	54.36	21.73	
95th-Percentile Queue Length [veh/ln]	4.81	1.37	3.91	1.56	
95th-Percentile Queue Length [ft/ln]	120.33	34.23	97.85	39.11	

**Movement, Approach, & Intersection Results**

d_M, Delay for Movement [s/veh]	0.00	9.77	0.00	0.00	6.83	0.00	12.54	0.00	10.56	0.00	0.00	0.00
Movement LOS		A			A		B		B			
d_A, Approach Delay [s/veh]	9.77				6.83		11.91		0.00			
Approach LOS	A				A		B		A			
d_I, Intersection Delay [s/veh]	10.06											
Intersection LOS	B											
Intersection V/C	0.843											

**Emissions**

Vehicle Miles Traveled [mph]	214.67	58.83	98.65	45.78
Stops [stops/h]	569.38	161.96	463.00	185.06
Fuel consumption [US gal/h]	14.46	4.53	9.41	3.98
CO [g/h]	1011.03	316.72	657.67	278.45
NOx [g/h]	196.71	61.62	127.96	54.18
VOC [g/h]	234.32	73.40	152.42	64.53

**Other Modes**

g_Walk,mi, Effective Walk Time [s]	0.0	0.0	0.0	-5.8
M_corner, Corner Circulation Area [ft <sup>2</sup> /ped]	0.00	0.00	0.00	0.00
M_CW, Crosswalk Circulation Area [ft <sup>2</sup> /ped]	0.00	0.00	0.00	0.00
d_p, Pedestrian Delay [s]	0.00	0.00	0.00	23.20
I_p,int, Pedestrian LOS Score for Intersectio	0.000	0.000	0.000	1.698
Crosswalk LOS	F	F	F	A
s_b, Saturation Flow Rate of the bicycle lane	2000	2000	2000	2000
c_b, Capacity of the bicycle lane [bicycles/h]	2366	2366	1538	0
d_b, Bicycle Delay [s]	0.57	0.57	0.90	16.91
I_b,int, Bicycle LOS Score for Intersection	2.588	2.054	1.560	4.132
Bicycle LOS	B	B	A	D

**Sequence**

Ring 1	-	2	-	4	-	-	-	-	-	-	-	-	-	-	-
Ring 2	-	6	-	-	-	-	-	-	-	-	-	-	-	-	-
Ring 3	-	-	-	-	-	-	-	-	-	-	-	-	-	-	-
Ring 4	-	-	-	-	-	-	-	-	-	-	-	-	-	-	-



**Intersection Level Of Service Report**  
**Intersection 13: El Charro Road & Jack London Boulevard**

Control Type:	Signalized	Delay (sec / veh):	76.7
Analysis Method:	HCM 7th Edition	Level Of Service:	E
Analysis Period:	15 minutes	Volume to Capacity (v/c):	0.870

**Intersection Setup**

Name	El Charro Road			El Charro Road			Stoneridge Drive			Jack London Boulevard		
Approach	Northbound			Southbound			Eastbound			Westbound		
Lane Configuration	TUT			RTURT			TURT			TUT		
Turning Movement	Left	Thru	Right	Left	Thru	Right	Left	Thru	Right	Left	Thru	Right
Lane Width [ft]	12.00	12.00	12.00	12.00	12.00	12.00	12.00	12.00	12.00	12.00	12.00	12.00
No. of Lanes in Entry Pocket	1	0	2	2	0	1	3	0	1	1	0	2
Entry Pocket Length [ft]	125.00	100.00	175.00	650.00	100.00	450.00	450.00	100.00	325.00	400.00	100.00	775.00
No. of Lanes in Exit Pocket	0	0	0	0	0	1	1	0	0	0	0	0
Exit Pocket Length [ft]	0.00	0.00	0.00	0.00	0.00	49.21	450.00	0.00	0.00	0.00	0.00	0.00
Speed [mph]	30.00			30.00			30.00			30.00		
Grade [%]	0.00			0.00			0.00			0.00		
Curb Present	Yes			Yes			Yes			Yes		
Crosswalk	Yes			No			Yes			Yes		





**Volumes**

Name	El Charro Road			El Charro Road			Stoneridge Drive			Jack London Boulevard		
Base Volume Input [veh/h]	97	614	27	239	209	504	274	77	22	93	705	669
Base Volume Adjustment Factor	1.0000	1.0000	1.0000	1.0000	1.0000	1.0000	1.0000	1.0000	1.0000	1.0000	1.0000	1.0000
Heavy Vehicles Percentage [%]	0.00	86.00	33.30	0.40	66.70	0.20	2.30	5.30	0.00	37.50	1.20	1.10
Proportion of CAVs [%]	0.00											
Growth Factor	1.0000	1.0000	1.0000	1.0000	1.0000	1.0000	1.0000	1.0000	1.0000	1.0000	1.0000	1.0000
In-Process Volume [veh/h]	0	0	0	0	0	0	0	0	0	0	0	0
Site-Generated Trips [veh/h]	0	0	0	0	0	0	0	0	0	0	0	0
Diverted Trips [veh/h]	0	0	0	0	0	0	0	0	0	0	0	0
Pass-by Trips [veh/h]	0	0	0	0	0	0	0	0	0	0	0	0
Existing Site Adjustment Volume [veh/h]	0	0	0	0	0	0	0	0	0	0	0	0
Other Volume [veh/h]	0	0	0	0	0	0	0	0	0	0	0	0
Right Turn on Red Volume [veh/h]	0	0	0	0	0	0	0	0	0	0	0	0
Total Hourly Volume [veh/h]	97	614	27	239	209	504	274	77	22	93	705	669
Peak Hour Factor	0.8900	0.8900	0.8900	0.8900	0.8900	0.8900	0.8900	0.8900	0.8900	0.8900	0.8900	0.8900
Other Adjustment Factor	1.0000	1.0000	1.0000	1.0000	1.0000	1.0000	1.0000	1.0000	1.0000	1.0000	1.0000	1.0000
Total 15-Minute Volume [veh/h]	27	172	8	67	59	142	77	22	6	26	198	188
Total Analysis Volume [veh/h]	109	690	30	269	235	566	308	87	25	104	792	752
Presence of On-Street Parking	No		No	No		No	No		No	No		No
On-Street Parking Maneuver Rate [/h]	0	0	0	0	0	0	0	0	0	0	0	0
Local Bus Stopping Rate [/h]	0	0	0	0	0	0	0	0	0	0	0	0
v_do, Outbound Pedestrian Volume crossing	0			0			0			0		
v_di, Inbound Pedestrian Volume crossing m	0			0			0			0		
v_co, Outbound Pedestrian Volume crossing	0			0			0			1		
v_ci, Inbound Pedestrian Volume crossing mi	1			0			0			0		
v_ab, Corner Pedestrian Volume [ped/h]	0			0			0			0		
Bicycle Volume [bicycles/h]	0			0			1			0		



**Intersection Settings**

Located in CBD	No
Signal Coordination Group	-
Cycle Length [s]	90
Active Pattern	Free Running (No Pattern)
Coordination Type	<i>Free Running</i>
Actuation Type	<i>Fully actuated</i>
Offset [s]	0.0
Offset Reference	Lead Green - Beginning of First Green
Permissive Mode	SingleBand
Lost time [s]	12.00

**Phasing & Timing (Basic)**

Control Type	Protecte	Permiss	Permiss	Protecte	Permiss	Unsigna	Protecte	Permiss	Permiss	Protecte	Permiss	Overlap
Signal Group	7	4	0	3	8	0	1	6	0	5	2	2
Auxiliary Signal Groups												2,3
Maximum Green [s]	13	25	0	35	20	0	20	25	0	15	20	20
Amber [s]	3.0	5.0	0.0	3.0	4.3	0.0	3.0	4.3	0.0	3.0	4.3	4.3
All red [s]	1.0	1.0	0.0	1.0	1.0	0.0	1.0	1.0	0.0	1.0	1.0	1.0
Walk [s]	0	5	0	0	5	0	0	5	0	0	0	0
Pedestrian Clearance [s]	0	28	0	0	28	0	0	30	0	0	0	0
Delayed Vehicle Green [s]	0.0	0.0	0.0	0.0	0.0	0.0	0.0	0.0	0.0	0.0	0.0	0.0
Rest In Walk		No			No			No			No	
I1, Start-Up Lost Time [s]	2.0	2.0	0.0	2.0	2.0	0.0	2.0	2.0	0.0	2.0	2.0	2.0
I2, Clearance Lost Time [s]	2.0	2.0	0.0	2.0	2.0	0.0	2.0	2.0	0.0	2.0	2.0	2.0
Detector Location [ft]	0.0	0.0	0.0	0.0	0.0	0.0	0.0	0.0	0.0	0.0	0.0	0.0
Detector Length [ft]	20.0	20.0	0.0	20.0	20.0	0.0	20.0	20.0	0.0	0.0	0.0	0.0
I, Upstream Filtering Factor	1.00	1.00	1.00	1.00	1.00	1.00	1.00	1.00	1.00	1.00	1.00	1.00

**Phasing & Timing: Free Running (No Pattern)**

Split [s]	0	0	0	0	0	0	0	0	0	0	0	0
Lead / Lag	Lead	-	-	Lead	-	-	Lead	-	-	Lead	-	-
Minimum Green [s]	4	5	0	7	5	0	5	4	0	4	7	7
Vehicle Extension [s]	2.0	2.5	0.0	2.5	2.5	0.0	2.0	3.0	0.0	2.0	3.0	3.0
Minimum Recall	No	No		No	No		No	Yes		No	Yes	Yes
Maximum Recall	No	No		No	No		No	No		No	No	No
Pedestrian Recall	No	No		No	No		No	No		No	No	No

**Exclusive Pedestrian Phase**

Pedestrian Signal Group	0
Pedestrian Walk [s]	0
Pedestrian Clearance [s]	0



**Lane Group Calculations**

Lane Group	L	C	C	L	C	L	C	R	L	C	R
C, Cycle Length [s]	94	94	94	94	94	94	94	94	94	94	94
L, Total Lost Time per Cycle [s]	4.00	4.00	4.00	4.00	4.00	4.00	4.00	4.00	4.00	4.00	4.00
l1_p, Permitted Start-Up Lost Time [s]	0.00	0.00	0.00	0.00	0.00	0.00	0.00	0.00	0.00	0.00	0.00
l2, Clearance Lost Time [s]	2.00	2.00	2.00	2.00	2.00	2.00	2.00	2.00	2.00	2.00	0.00
g_i, Effective Green Time [s]	7	27	27	22	42	8	20	20	9	21	47
g / C, Green / Cycle	0.08	0.29	0.29	0.23	0.44	0.08	0.21	0.21	0.10	0.23	0.50
(v / s)_i Volume / Saturation Flow Rate	0.06	0.41	0.41	0.05	0.26	0.06	0.03	0.02	0.08	0.22	0.27
s, saturation flow rate [veh/h]	1810	1160	596	5254	899	5175	3466	1580	1273	3583	2834
c, Capacity [veh/h]	139	331	170	1235	399	440	743	339	122	807	1424
d1, Uniform Delay [s]	42.88	33.78	33.78	29.17	19.82	42.08	29.94	29.65	42.07	36.43	15.93
k, delay calibration	0.04	0.26	0.50	0.08	0.50	0.04	0.11	0.11	0.04	0.11	0.16
l, Upstream Filtering Factor	1.00	1.00	1.00	1.00	1.00	1.00	1.00	1.00	1.00	1.00	1.00
d2, Incremental Delay [s]	3.63	204.35	228.04	0.07	6.27	0.76	0.07	0.09	6.15	10.97	0.46
d3, Initial Queue Delay [s]	0.00	0.00	0.00	0.00	0.00	0.00	0.00	0.00	0.00	0.00	0.00
Rp, platoon ratio	1.00	1.00	1.00	1.00	1.00	1.00	1.00	1.00	1.00	1.00	1.00
PF, progression factor	1.00	1.00	1.00	1.00	1.00	1.00	1.00	1.00	1.00	1.00	1.00

**Lane Group Results**

X, volume / capacity	0.78	1.43	1.44	0.22	0.59	0.70	0.12	0.07	0.85	0.98	0.53
d, Delay for Lane Group [s/veh]	46.51	238.13	261.82	29.23	26.08	42.84	30.01	29.74	48.22	47.40	16.39
Lane Group LOS	D	F	F	C	C	D	C	C	D	D	B
Critical Lane Group	No	No	Yes	No	No	Yes	No	No	No	Yes	Yes
50th-Percentile Queue Length [veh/ln]	2.62	13.07	14.56	1.63	4.42	2.34	0.80	0.46	2.57	10.10	5.30
50th-Percentile Queue Length [ft/ln]	65.41	326.85	364.02	40.83	110.55	58.45	19.96	11.47	64.25	252.43	132.50
95th-Percentile Queue Length [veh/ln]	4.71	22.39	24.63	2.94	7.87	4.21	1.44	0.83	4.63	15.31	9.08
95th-Percentile Queue Length [ft/ln]	117.75	559.85	615.67	73.50	196.76	105.20	35.92	20.65	115.64	382.72	226.89



**Movement, Approach, & Intersection Results**

d_M, Delay for Movement [s/veh]	46.51	245.52	261.82	29.23	26.08	0.00	42.84	30.01	29.74	48.22	47.40	16.39
Movement LOS	D	F	F	C	C		D	C	C	D	D	B
d_A, Approach Delay [s/veh]	219.94			13.88			39.40			33.30		
Approach LOS	F			B			D			C		
d_I, Intersection Delay [s/veh]	76.67											
Intersection LOS	E											
Intersection V/C	0.870											

**Emissions**

Vehicle Miles Traveled [mph]	6.92	30.14	15.56	46.31	40.46	32.98	9.32	2.68	18.07	137.60	130.65
Stops [stops/h]	99.70	996.31	554.82	186.71	168.49	267.24	60.83	17.48	97.92	769.49	403.89
Fuel consumption [US gal/h]	1.87	29.75	16.76	4.54	3.84	5.52	1.25	0.36	2.31	17.56	10.12
CO [g/h]	130.52	2079.78	1171.72	317.21	268.67	385.78	87.43	25.03	161.14	1227.12	707.27
NOx [g/h]	25.39	404.65	227.97	61.72	52.27	75.06	17.01	4.87	31.35	238.75	137.61
VOC [g/h]	30.25	482.01	271.56	73.52	62.27	89.41	20.26	5.80	37.35	284.40	163.92

**Other Modes**

g_Walk,mi, Effective Walk Time [s]	9.0	0.0	9.0	9.0
M_corner, Corner Circulation Area [ft <sup>2</sup> /ped]	0.00	0.00	0.00	0.00
M_CW, Crosswalk Circulation Area [ft <sup>2</sup> /ped]	0.00	0.00	0.00	0.00
d_p, Pedestrian Delay [s]	38.67	0.00	38.67	38.67
I_p,int, Pedestrian LOS Score for Intersectio	2.536	0.000	2.996	2.977
Crosswalk LOS	B	F	C	C
s_b, Saturation Flow Rate of the bicycle lane	2000	2000	2000	2000
c_b, Capacity of the bicycle lane [bicycles/h]	529	423	529	423
d_b, Bicycle Delay [s]	25.55	29.36	25.56	29.36
I_b,int, Bicycle LOS Score for Intersection	2.016	2.391	1.906	2.919
Bicycle LOS	B	B	A	C

**Sequence**

Ring 1	1	2	3	4	-	-	-	-	-	-	-	-	-	-	-
Ring 2	5	6	7	8	-	-	-	-	-	-	-	-	-	-	-
Ring 3	-	-	-	-	-	-	-	-	-	-	-	-	-	-	-
Ring 4	-	-	-	-	-	-	-	-	-	-	-	-	-	-	-



**Intersection Level Of Service Report**  
**Intersection 14: Central Parkway & Sunset View Drive**

Control Type:	Signalized	Delay (sec / veh):	34.4
Analysis Method:	HCM 7th Edition	Level Of Service:	C
Analysis Period:	15 minutes	Volume to Capacity (v/c):	0.791

**Intersection Setup**

Name	Driveway			Sunset View Drive			Central Parkway			Central Parkway		
Approach	Northbound			Southbound			Eastbound			Westbound		
Lane Configuration	⇐⇑			⇑⇐			⇑⇐⇑			⇑⇐		
Turning Movement	Left	Thru	Right	Left	Thru	Right	Left	Thru	Right	Left	Thru	Right
Lane Width [ft]	12.00	12.00	12.00	12.00	12.00	12.00	12.00	12.00	12.00	12.00	12.00	12.00
No. of Lanes in Entry Pocket	1	0	0	0	0	1	1	0	1	1	0	0
Entry Pocket Length [ft]	250.00	100.00	100.00	100.00	100.00	85.00	225.00	100.00	800.00	150.00	100.00	100.00
No. of Lanes in Exit Pocket	0	0	0	0	0	0	0	0	0	0	0	0
Exit Pocket Length [ft]	0.00	0.00	0.00	0.00	0.00	0.00	0.00	0.00	0.00	0.00	0.00	0.00
Speed [mph]	30.00			30.00			30.00			30.00		
Grade [%]	0.00			0.00			0.00			0.00		
Curb Present	No			No			No			No		
Crosswalk	Yes			Yes			Yes			Yes		



**Volumes**

Name	Driveway			Sunset View Drive			Central Parkway			Central Parkway		
Base Volume Input [veh/h]	160	18	12	17	15	149	40	173	167	31	244	2
Base Volume Adjustment Factor	1.0000	1.0000	1.0000	1.0000	1.0000	1.0000	1.0000	1.0000	1.0000	1.0000	1.0000	1.0000
Heavy Vehicles Percentage [%]	0.70	0.00	0.00	0.00	0.00	2.00	2.50	1.70	0.00	0.00	0.40	0.00
Proportion of CAVs [%]	0.00											
Growth Factor	1.0000	1.0000	1.0000	1.0000	1.0000	1.0000	1.0000	1.0000	1.0000	1.0000	1.0000	1.0000
In-Process Volume [veh/h]	0	0	0	0	0	0	0	0	0	0	0	0
Site-Generated Trips [veh/h]	0	0	0	0	0	0	0	0	0	0	0	0
Diverted Trips [veh/h]	0	0	0	0	0	0	0	0	0	0	0	0
Pass-by Trips [veh/h]	0	0	0	0	0	0	0	0	0	0	0	0
Existing Site Adjustment Volume [veh/h]	0	0	0	0	0	0	0	0	0	0	0	0
Other Volume [veh/h]	0	0	0	0	0	0	0	0	0	0	0	0
Right Turn on Red Volume [veh/h]	0	0	0	0	0	0	0	0	0	0	0	0
Total Hourly Volume [veh/h]	160	18	12	17	15	149	40	173	167	31	244	2
Peak Hour Factor	0.5500	0.5500	0.5500	0.5500	0.5500	0.5500	0.5500	0.5500	0.5500	0.5500	0.5500	0.5500
Other Adjustment Factor	1.0000	1.0000	1.0000	1.0000	1.0000	1.0000	1.0000	1.0000	1.0000	1.0000	1.0000	1.0000
Total 15-Minute Volume [veh/h]	73	8	5	8	7	68	18	79	76	14	111	1
Total Analysis Volume [veh/h]	291	33	22	31	27	271	73	315	304	56	444	4
Presence of On-Street Parking	No		No	No		No	No		No	No		No
On-Street Parking Maneuver Rate [/h]	0	0	0	0	0	0	0	0	0	0	0	0
Local Bus Stopping Rate [/h]	0	0	0	0	0	0	0	0	0	0	0	0
v_do, Outbound Pedestrian Volume crossing	74			14			74			14		
v_di, Inbound Pedestrian Volume crossing m	74			14			74			14		
v_co, Outbound Pedestrian Volume crossing	123			37			37			124		
v_ci, Inbound Pedestrian Volume crossing mi	124			37			37			123		
v_ab, Corner Pedestrian Volume [ped/h]	0			0			0			0		
Bicycle Volume [bicycles/h]	2			0			11			0		



**Intersection Settings**

Located in CBD	No
Signal Coordination Group	-
Cycle Length [s]	90
Active Pattern	Free Running (No Pattern)
Coordination Type	<i>Free Running</i>
Actuation Type	<i>Fully actuated</i>
Offset [s]	0.0
Offset Reference	Lead Green - Beginning of First Green
Permissive Mode	SingleBand
Lost time [s]	12.00

**Phasing & Timing (Basic)**

Control Type	Protecte	Permiss	Permiss	Protecte	Permiss	Permiss	Protecte	Permiss	Permiss	Protecte	Permiss	Permiss
Signal Group	3	8	0	7	4	0	5	2	0	1	6	0
Auxiliary Signal Groups												
Maximum Green [s]	30	30	0	20	20	0	20	25	0	20	25	0
Amber [s]	3.0	3.0	0.0	3.0	3.0	0.0	3.0	3.6	0.0	3.0	3.6	0.0
All red [s]	1.0	1.0	0.0	1.0	1.0	0.0	1.0	1.0	0.0	1.0	1.0	0.0
Walk [s]	0	4	0	0	4	0	0	4	0	0	4	0
Pedestrian Clearance [s]	0	24	0	0	21	0	0	16	0	0	17	0
Delayed Vehicle Green [s]	0.0	0.0	0.0	0.0	0.0	0.0	0.0	0.0	0.0	0.0	0.0	0.0
Rest In Walk		No			No			No			No	
I1, Start-Up Lost Time [s]	2.0	2.0	0.0	2.0	2.0	0.0	2.0	2.0	0.0	2.0	2.0	0.0
I2, Clearance Lost Time [s]	2.0	2.0	0.0	2.0	2.0	0.0	2.0	2.0	0.0	2.0	2.0	0.0
Detector Location [ft]	0.0	0.0	0.0	0.0	0.0	0.0	0.0	0.0	0.0	0.0	0.0	0.0
Detector Length [ft]	20.0	20.0	0.0	20.0	20.0	0.0	20.0	20.0	0.0	20.0	20.0	0.0
I, Upstream Filtering Factor	1.00	1.00	1.00	1.00	1.00	1.00	1.00	1.00	1.00	1.00	1.00	1.00

**Phasing & Timing: Free Running (No Pattern)**

Split [s]	9	14	0	9	14	0	9	14	0	9	14	0
Lead / Lag	Lead	-	-	Lead	-	-	Lead	-	-	Lead	-	-
Minimum Green [s]	5	10	0	5	10	0	5	10	0	5	10	0
Vehicle Extension [s]	2.0	4.0	0.0	2.0	4.0	0.0	2.0	4.0	0.0	2.0	4.0	0.0
Minimum Recall	No	No		No	No		No	Yes		No	Yes	
Maximum Recall	No	No		No	No		No	No		No	No	
Pedestrian Recall	No	No		No	No		No	No		No	No	

**Exclusive Pedestrian Phase**

Pedestrian Signal Group	0
Pedestrian Walk [s]	0
Pedestrian Clearance [s]	0



**Lane Group Calculations**

Lane Group	L	C	L	C	L	C	R	L	C
C, Cycle Length [s]	75	75	75	75	75	75	75	75	75
L, Total Lost Time per Cycle [s]	4.00	4.00	4.00	4.00	4.00	4.00	4.00	4.00	4.00
l1_p, Permitted Start-Up Lost Time [s]	0.00	0.00	0.00	0.00	0.00	0.00	0.00	0.00	0.00
l2, Clearance Lost Time [s]	2.00	2.00	2.00	2.00	2.00	2.00	2.00	2.00	2.00
g_i, Effective Green Time [s]	14	32	2	20	4	22	22	3	21
g / C, Green / Cycle	0.19	0.42	0.03	0.27	0.05	0.29	0.29	0.05	0.28
(v / s)_i Volume / Saturation Flow Rate	0.16	0.04	0.02	0.21	0.04	0.17	0.26	0.03	0.24
s, saturation flow rate [veh/h]	1800	1485	1810	1424	1774	1874	1158	1810	1890
c, Capacity [veh/h]	341	627	58	378	96	538	332	84	528
d1, Uniform Delay [s]	29.57	13.07	35.94	25.76	35.20	23.04	23.62	35.40	25.68
k, delay calibration	0.04	0.15	0.04	0.30	0.04	0.15	0.32	0.04	0.27
l, Upstream Filtering Factor	1.00	1.00	1.00	1.00	1.00	1.00	1.00	1.00	1.00
d2, Incremental Delay [s]	2.39	0.09	2.78	9.85	4.59	1.44	22.96	3.38	9.00
d3, Initial Queue Delay [s]	0.00	0.00	0.00	0.00	0.00	0.00	0.00	0.00	0.00
Rp, platoon ratio	1.00	1.00	1.00	1.00	1.00	1.00	1.00	1.00	1.00
PF, progression factor	1.00	1.00	1.00	1.00	1.00	1.00	1.00	1.00	1.00

**Lane Group Results**

X, volume / capacity	0.85	0.09	0.53	0.79	0.76	0.59	0.91	0.67	0.85
d, Delay for Lane Group [s/veh]	31.96	13.16	38.72	35.61	39.78	24.49	46.58	38.78	34.68
Lane Group LOS	C	B	D	D	D	C	D	D	C
Critical Lane Group	Yes	No	No	Yes	No	No	Yes	Yes	No
50th-Percentile Queue Length [veh/ln]	5.11	0.54	0.59	5.73	1.41	4.77	6.62	1.06	8.48
50th-Percentile Queue Length [ft/ln]	127.79	13.49	14.81	143.26	35.22	119.26	165.62	26.61	211.91
95th-Percentile Queue Length [veh/ln]	8.82	0.97	1.07	9.66	2.54	8.35	10.85	1.92	13.25
95th-Percentile Queue Length [ft/ln]	220.48	24.28	26.65	241.41	63.39	208.82	271.14	47.90	331.28



**Movement, Approach, & Intersection Results**

d_M, Delay for Movement [s/veh]	31.96	13.16	13.16	38.72	35.61	35.61	39.78	24.49	46.58	38.78	34.68	34.68
Movement LOS	C	B	B	D	D	D	D	C	D	D	C	C
d_A, Approach Delay [s/veh]	28.97			35.90			35.81			35.13		
Approach LOS	C			D			D			D		
d_I, Intersection Delay [s/veh]	34.38											
Intersection LOS	C											
Intersection V/C	0.791											

**Emissions**

Vehicle Miles Traveled [mph]	7.93	1.50	1.15	11.08	16.60	71.61	69.11	11.84	94.71
Stops [stops/h]	244.50	25.81	28.33	274.11	67.38	228.19	316.88	50.92	405.46
Fuel consumption [US gal/h]	3.57	0.35	0.45	4.13	1.65	5.78	7.48	1.21	9.30
CO [g/h]	249.51	24.57	31.33	288.66	115.09	403.92	522.65	84.62	650.08
NOx [g/h]	48.55	4.78	6.10	56.16	22.39	78.59	101.69	16.46	126.48
VOC [g/h]	57.83	5.70	7.26	66.90	26.67	93.61	121.13	19.61	150.66

**Other Modes**

g_Walk,mi, Effective Walk Time [s]	8.0	8.0	8.0	8.0
M_corner, Corner Circulation Area [ft <sup>2</sup> /ped]	0.00	0.00	0.00	0.00
M_CW, Crosswalk Circulation Area [ft <sup>2</sup> /ped]	0.00	0.00	0.00	0.00
d_p, Pedestrian Delay [s]	30.06	30.06	30.06	30.06
I_p,int, Pedestrian LOS Score for Intersectio	2.172	2.077	2.539	2.217
Crosswalk LOS	B	B	B	B
s_b, Saturation Flow Rate of the bicycle lane	2000	2000	2000	2000
c_b, Capacity of the bicycle lane [bicycles/h]	797	531	664	664
d_b, Bicycle Delay [s]	13.62	20.29	16.88	16.78
I_b,int, Bicycle LOS Score for Intersection	2.131	2.102	2.701	2.391
Bicycle LOS	B	B	B	B

**Sequence**

Ring 1	1	2	3	4	-	-	-	-	-	-	-	-	-	-	-
Ring 2	5	6	7	8	-	-	-	-	-	-	-	-	-	-	-
Ring 3	-	-	-	-	-	-	-	-	-	-	-	-	-	-	-
Ring 4	-	-	-	-	-	-	-	-	-	-	-	-	-	-	-

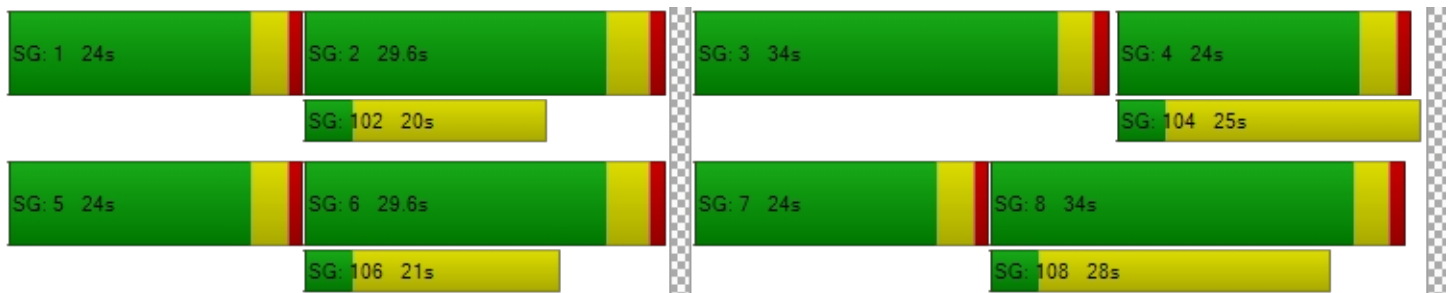

**Intersection Level Of Service Report**

**Intersection 15: Central Parkway & Panorama Drive/Pino Grande Road**

Control Type:	All-way stop	Delay (sec / veh):	12.0
Analysis Method:	HCM 7th Edition	Level Of Service:	B
Analysis Period:	15 minutes	Volume to Capacity (v/c):	0.377

**Intersection Setup**

Name	Pino Grande Road			Panorama Drive			Central Parkway			Central Parkway		
Approach	Northbound			Southbound			Eastbound			Westbound		
Lane Configuration	+			+			+			+		
Turning Movement	Left	Thru	Right	Left	Thru	Right	Left	Thru	Right	Left	Thru	Right
Lane Width [ft]	12.00	12.00	12.00	12.00	12.00	12.00	12.00	12.00	12.00	12.00	12.00	12.00
No. of Lanes in Entry Pocket	0	0	0	0	0	1	1	0	0	1	0	0
Entry Pocket Length [ft]	100.00	100.00	100.00	100.00	100.00	100.00	275.00	100.00	100.00	100.00	100.00	100.00
No. of Lanes in Exit Pocket	0	0	0	0	0	0	0	0	0	0	0	0
Exit Pocket Length [ft]	0.00	0.00	0.00	0.00	0.00	0.00	0.00	0.00	0.00	0.00	0.00	0.00
Speed [mph]	30.00			30.00			30.00			30.00		
Grade [%]	0.00			0.00			0.00			0.00		
Crosswalk	Yes			Yes			Yes			Yes		

**Volumes**

Name	Pino Grande Road			Panorama Drive			Central Parkway			Central Parkway		
Base Volume Input [veh/h]	79	3	10	1	4	127	97	84	6	2	91	2
Base Volume Adjustment Factor	1.0000	1.0000	1.0000	1.0000	1.0000	1.0000	1.0000	1.0000	1.0000	1.0000	1.0000	1.0000
Heavy Vehicles Percentage [%]	0.00	0.00	0.00	0.00	0.00	0.00	2.10	1.20	0.00	0.00	0.00	0.00
Growth Factor	1.0000	1.0000	1.0000	1.0000	1.0000	1.0000	1.0000	1.0000	1.0000	1.0000	1.0000	1.0000
In-Process Volume [veh/h]	0	0	0	0	0	0	0	0	0	0	0	0
Site-Generated Trips [veh/h]	0	0	0	0	0	0	0	0	0	0	0	0
Diverted Trips [veh/h]	0	0	0	0	0	0	0	0	0	0	0	0
Pass-by Trips [veh/h]	0	0	0	0	0	0	0	0	0	0	0	0
Existing Site Adjustment Volume [veh/h]	0	0	0	0	0	0	0	0	0	0	0	0
Other Volume [veh/h]	0	0	0	0	0	0	0	0	0	0	0	0
Total Hourly Volume [veh/h]	79	3	10	1	4	127	97	84	6	2	91	2
Peak Hour Factor	0.5300	0.5300	0.5300	0.5300	0.5300	0.5300	0.5300	0.5300	0.5300	0.5300	0.5300	0.5300
Other Adjustment Factor	1.0000	1.0000	1.0000	1.0000	1.0000	1.0000	1.0000	1.0000	1.0000	1.0000	1.0000	1.0000
Total 15-Minute Volume [veh/h]	37	1	5	0	2	60	46	40	3	1	43	1
Total Analysis Volume [veh/h]	149	6	19	2	8	240	183	158	11	4	172	4
Pedestrian Volume [ped/h]	117			1			103			89		



**Intersection Settings****Lanes**

Capacity per Entry Lane [veh/h]	550	558	638	542	593	524	568
Degree of Utilization, x	0.32	0.02	0.38	0.34	0.28	0.01	0.31





**Movement, Approach, & Intersection Results**

95th-Percentile Queue Length [veh]	1.35	0.05	1.75	1.48	1.17	0.02	1.31
95th-Percentile Queue Length [ft]	33.79	1.37	43.75	36.99	29.25	0.58	32.78
Approach Delay [s/veh]	12.56	11.62		11.96		11.80	
Approach LOS	B	B		B		B	
Intersection Delay [s/veh]	11.95						
Intersection LOS	B						

**Intersection Level Of Service Report**  
**Intersection 16: Airway Boulevard & N. Canyons Parkway**

Control Type:	Signalized	Delay (sec / veh):	25.1
Analysis Method:	HCM 7th Edition	Level Of Service:	C
Analysis Period:	15 minutes	Volume to Capacity (v/c):	0.728

**Intersection Setup**

Name	Airway Boulevard			Driveway			N. Canyons Parkway			N Canyons Parkway		
Approach	Northbound			Southbound			Eastbound			Westbound		
Lane Configuration												
Turning Movement	Left	Thru	Right	Left	Thru	Right	Left	Thru	Right	Left	Thru	Right
Lane Width [ft]	12.00	12.00	12.00	12.00	12.00	12.00	12.00	12.00	12.00	12.00	12.00	12.00
No. of Lanes in Entry Pocket	1	0	0	0	0	0	0	0	0	1	0	1
Entry Pocket Length [ft]	100.00	100.00	100.00	100.00	100.00	100.00	100.00	100.00	100.00	110.00	100.00	195.00
No. of Lanes in Exit Pocket	0	0	0	0	0	0	0	0	0	0	0	0
Exit Pocket Length [ft]	0.00	0.00	0.00	0.00	0.00	0.00	0.00	0.00	0.00	0.00	0.00	0.00
Speed [mph]	40.00			30.00			40.00			40.00		
Grade [%]	0.00			0.00			0.00			0.00		
Curb Present	Yes			Yes			Yes			Yes		
Crosswalk	Yes			Yes			Yes			No		



**Volumes**

Name	Airway Boulevard			Driveway			N. Canyons Parkway			N Canyons Parkway		
Base Volume Input [veh/h]	852	14	558	1	4	0	0	165	179	657	1165	1
Base Volume Adjustment Factor	1.0000	1.0000	1.0000	1.0000	1.0000	1.0000	1.0000	1.0000	1.0000	1.0000	1.0000	1.0000
Heavy Vehicles Percentage [%]	3.60	0.00	2.10	0.00	0.00	0.00	2.00	0.00	22.60	4.40	0.00	0.00
Proportion of CAVs [%]	0.00											
Growth Factor	1.0000	1.0000	1.0000	1.0000	1.0000	1.0000	1.0000	1.0000	1.0000	1.0000	1.0000	1.0000
In-Process Volume [veh/h]	0	0	0	0	0	0	0	0	0	0	0	0
Site-Generated Trips [veh/h]	0	0	0	0	0	0	0	0	0	0	0	0
Diverted Trips [veh/h]	0	0	0	0	0	0	0	0	0	0	0	0
Pass-by Trips [veh/h]	0	0	0	0	0	0	0	0	0	0	0	0
Existing Site Adjustment Volume [veh/h]	0	0	0	0	0	0	0	0	0	0	0	0
Other Volume [veh/h]	0	0	0	0	0	0	0	0	0	0	0	0
Right Turn on Red Volume [veh/h]	0	0	0	0	0	0	0	0	0	0	0	0
Total Hourly Volume [veh/h]	852	14	558	1	4	0	0	165	179	657	1165	1
Peak Hour Factor	0.8900	0.8900	0.8900	0.8900	0.8900	0.8900	1.0000	0.8900	0.8900	0.8900	0.8900	0.8900
Other Adjustment Factor	1.0000	1.0000	1.0000	1.0000	1.0000	1.0000	1.0000	1.0000	1.0000	1.0000	1.0000	1.0000
Total 15-Minute Volume [veh/h]	239	4	157	0	1	0	0	46	50	185	327	0
Total Analysis Volume [veh/h]	957	16	627	1	4	0	0	185	201	738	1309	1
Presence of On-Street Parking	No		No	No		No	No		No	No		No
On-Street Parking Maneuver Rate [/h]	0	0	0	0	0	0	0	0	0	0	0	0
Local Bus Stopping Rate [/h]	0	0	0	0	0	0	0	0	0	0	0	0
v_do, Outbound Pedestrian Volume crossing	0			0			0			0		
v_di, Inbound Pedestrian Volume crossing m	0			0			0			0		
v_co, Outbound Pedestrian Volume crossing	0			1			0			0		
v_ci, Inbound Pedestrian Volume crossing mi	0			0			0			1		
v_ab, Corner Pedestrian Volume [ped/h]	0			0			0			0		
Bicycle Volume [bicycles/h]	0			0			0			0		



**Intersection Settings**

Located in CBD	No
Signal Coordination Group	-
Cycle Length [s]	105
Active Pattern	Pattern 1
Coordination Type	Time of Day Pattern Coordinated
Actuation Type	Fully actuated
Offset [s]	0.0
Offset Reference	Lead Green - Beginning of First Green
Permissive Mode	SingleBand
Lost time [s]	12.00

**Phasing & Timing (Basic)**

Control Type	Split	Split	Overlap	Split	Split	Split	Permiss	Permiss	Permiss	Protecte	Permiss	Permiss
Signal Group	0	8	8	0	4	0	0	2	0	1	6	0
Auxiliary Signal Groups			1,8									
Maximum Green [s]	0	20	20	0	12	0	0	15	0	50	50	0
Amber [s]	0.0	3.2	3.2	0.0	3.0	0.0	0.0	5.0	0.0	5.0	5.0	0.0
All red [s]	0.0	1.0	1.0	0.0	1.0	0.0	0.0	1.0	0.0	1.0	1.0	0.0
Walk [s]	0	0	0	0	5	0	0	5	0	0	5	0
Pedestrian Clearance [s]	0	0	0	0	28	0	0	29	0	0	12	0
Delayed Vehicle Green [s]	0.0	0.0	0.0	0.0	0.0	0.0	0.0	0.0	0.0	0.0	0.0	0.0
Rest In Walk		No			No			No			No	
I1, Start-Up Lost Time [s]	0.0	2.0	2.0	0.0	2.0	0.0	0.0	2.0	0.0	2.0	2.0	0.0
I2, Clearance Lost Time [s]	0.0	2.0	2.0	0.0	2.0	0.0	0.0	2.0	0.0	2.0	2.0	0.0
Detector Location [ft]	0.0	0.0	0.0	0.0	0.0	0.0	0.0	0.0	0.0	0.0	0.0	0.0
Detector Length [ft]	0.0	0.0	0.0	0.0	20.0	0.0	0.0	20.0	0.0	0.0	0.0	0.0
I, Upstream Filtering Factor	1.00	1.00	1.00	1.00	1.00	1.00	1.00	1.00	1.00	1.00	1.00	1.00

**Phasing & Timing: Pattern 1**

Split [s]	0	15	15	0	41	0	0	40	0	9	49	0
Lead / Lag	-	-	-	-	-	-	-	-	-	Lead	-	-
Minimum Green [s]	0	4	4	0	3	0	0	10	0	3	7	0
Vehicle Extension [s]	0.0	2.0	2.0	0.0	2.0	0.0	0.0	2.0	0.0	2.0	2.0	0.0
Minimum Recall		No	No		No			No		No	Yes	
Maximum Recall		No	No		No			No		Yes	Yes	
Pedestrian Recall		No	No		No			No		No	No	

**Exclusive Pedestrian Phase**

Pedestrian Signal Group	0
Pedestrian Walk [s]	0
Pedestrian Clearance [s]	0



**Lane Group Calculations**

Lane Group	L	C	R	C	C	R	L	C	C
C, Cycle Length [s]	105	105	105	105	105	105	105	105	105
L, Total Lost Time per Cycle [s]	4.00	4.00	4.00	4.00	4.00	4.00	4.00	4.00	4.00
l1_p, Permitted Start-Up Lost Time [s]	0.00	0.00	0.00	0.00	0.00	0.00	0.00	0.00	0.00
l2, Clearance Lost Time [s]	2.00	2.00	0.00	2.00	2.00	2.00	2.00	2.00	2.00
g_i, Effective Green Time [s]	32	32	73	0	20	20	37	61	61
g / C, Green / Cycle	0.30	0.30	0.69	0.00	0.19	0.19	0.36	0.58	0.58
(v / s)_i Volume / Saturation Flow Rate	0.27	0.27	0.22	0.00	0.05	0.15	0.22	0.34	0.34
s, saturation flow rate [veh/h]	1758	1812	2811	1881	3618	1327	3392	1900	1899
c, Capacity [veh/h]	527	544	1896	8	680	249	1206	1105	1105
d1, Uniform Delay [s]	35.38	35.36	7.16	52.22	36.49	40.81	27.87	14.03	14.03
k, delay calibration	0.04	0.04	0.50	0.04	0.04	0.04	0.50	0.50	0.50
l, Upstream Filtering Factor	1.00	1.00	1.00	1.00	1.00	1.00	1.00	1.00	1.00
d2, Incremental Delay [s]	2.58	2.47	0.47	29.18	0.08	2.34	2.32	2.34	2.34
d3, Initial Queue Delay [s]	0.00	0.00	0.00	0.00	0.00	0.00	0.00	0.00	0.00
Rp, platoon ratio	1.00	1.00	1.00	1.00	1.00	1.00	1.00	1.00	1.00
PF, progression factor	1.00	1.00	1.00	1.00	1.00	1.00	1.00	1.00	1.00

**Lane Group Results**

X, volume / capacity	0.91	0.91	0.33	0.65	0.27	0.81	0.61	0.59	0.59
d, Delay for Lane Group [s/veh]	37.96	37.83	7.62	81.40	36.57	43.15	30.19	16.37	16.37
Lane Group LOS	D	D	A	F	D	D	C	B	B
Critical Lane Group	Yes	No	No	Yes	No	Yes	Yes	No	No
50th-Percentile Queue Length [veh/ln]	11.63	11.95	2.60	0.19	1.99	4.98	7.69	9.59	9.59
50th-Percentile Queue Length [ft/ln]	290.74	298.68	65.12	4.84	49.78	124.57	192.14	239.82	239.86
95th-Percentile Queue Length [veh/ln]	17.22	17.62	4.69	0.35	3.58	8.64	12.23	14.67	14.67
95th-Percentile Queue Length [ft/ln]	430.55	440.39	117.22	8.72	89.61	216.09	305.80	366.80	366.86

**Movement, Approach, & Intersection Results**

d_M, Delay for Movement [s/veh]	37.89	37.83	7.62	81.40	81.40	81.40	0.00	36.57	43.15	30.19	16.37	16.37
Movement LOS	D	D	A	F	F	F		D	D	C	B	B
d_A, Approach Delay [s/veh]	26.03			81.40				39.99		21.35		
Approach LOS	C			F				D		C		
d_I, Intersection Delay [s/veh]	25.06											
Intersection LOS	C											
Intersection V/C	0.728											

**Emissions**

Vehicle Miles Traveled [mph]	56.93	58.60	74.45	0.17	12.06	13.10	60.36	53.57	53.57
Stops [stops/h]	398.68	409.57	178.60	6.64	136.53	170.82	526.95	328.86	328.92
Fuel consumption [US gal/h]	9.66	9.92	5.39	0.13	3.15	3.91	11.87	7.33	7.33
CO [g/h]	675.21	693.51	377.06	8.85	220.17	273.46	829.93	512.43	512.50
NOx [g/h]	131.37	134.93	73.36	1.72	42.84	53.20	161.47	99.70	99.71
VOC [g/h]	156.49	160.73	87.39	2.05	51.03	63.38	192.34	118.76	118.78

**Other Modes**

g_Walk,mi, Effective Walk Time [s]	9.0	9.0	9.0	0.0
M_corner, Corner Circulation Area [ft <sup>2</sup> /ped]	0.00	0.00	0.00	0.00
M_CW, Crosswalk Circulation Area [ft <sup>2</sup> /ped]	0.00	5854.23	0.00	0.00
d_p, Pedestrian Delay [s]	43.89	43.89	43.89	0.00
I_p,int, Pedestrian LOS Score for Intersectio	3.075	1.735	2.998	0.000
Crosswalk LOS	C	A	C	F
s_b, Saturation Flow Rate of the bicycle lane	2000	2000	2000	2000
c_b, Capacity of the bicycle lane [bicycles/h]	206	705	648	819
d_b, Bicycle Delay [s]	42.26	22.02	24.01	18.31
I_b,int, Bicycle LOS Score for Intersection	4.200	1.568	1.878	3.249
Bicycle LOS	D	A	A	C

**Sequence**

Ring 1	1	2	4	8	-	-	-	-	-	-	-	-	-	-	-
Ring 2	-	6	-	-	-	-	-	-	-	-	-	-	-	-	-
Ring 3	-	-	-	-	-	-	-	-	-	-	-	-	-	-	-
Ring 4	-	-	-	-	-	-	-	-	-	-	-	-	-	-	-

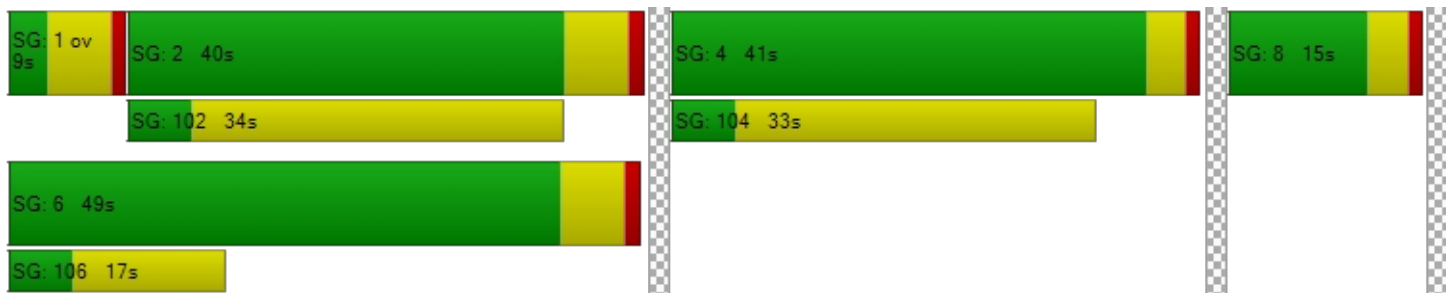



**Intersection Level Of Service Report**  
**Intersection 17: Airway Boulevard & I-580 WB Ramps**

Control Type:	Signalized	Delay (sec / veh):	42.7
Analysis Method:	HCM 7th Edition	Level Of Service:	D
Analysis Period:	15 minutes	Volume to Capacity (v/c):	0.482

**Intersection Setup**

Name	Airway Boulevard			Airway Boulevard			I-580 WB On-Ramp			I-580 WB Off-Ramp		
Approach	Northbound			Southbound			Eastbound			Westbound		
Lane Configuration	r			r						r rr		
Turning Movement	Left	Thru	Right	Left	Thru	Right	Left	Thru	Right	Left	Thru	Right
Lane Width [ft]	12.00	12.00	12.00	12.00	12.00	12.00	12.00	12.00	12.00	12.00	12.00	12.00
No. of Lanes in Entry Pocket	0	0	0	0	0	1	0	0	0	1	0	1
Entry Pocket Length [ft]	100.00	100.00	100.00	100.00	100.00	250.00	100.00	100.00	100.00	150.00	100.00	490.00
No. of Lanes in Exit Pocket	0	0	0	0	0	0	0	0	0	0	0	0
Exit Pocket Length [ft]	0.00	0.00	0.00	0.00	0.00	0.00	0.00	0.00	0.00	0.00	0.00	0.00
Speed [mph]	40.00			40.00			30.00			45.00		
Grade [%]	0.00			0.00			0.00			0.00		
Curb Present	Yes			Yes						Yes		
Crosswalk	No			No			No			Yes		



**Volumes**

Name	Airway Boulevard			Airway Boulevard			I-580 WB On-Ramp			I-580 WB Off-Ramp		
	Base Volume Input [veh/h]	0	932	131	0	239	641	0	0	0	51	0
Base Volume Adjustment Factor	1.0000	1.0000	1.0000	1.0000	1.0000	1.0000	1.0000	1.0000	1.0000	1.0000	1.0000	1.0000
Heavy Vehicles Percentage [%]	2.00	2.90	9.20	2.00	5.70	6.80	2.00	2.00	2.00	4.20	0.00	8.50
Proportion of CAVs [%]	0.00											
Growth Factor	1.0000	1.0000	1.0000	1.0000	1.0000	1.0000	1.0000	1.0000	1.0000	1.0000	1.0000	1.0000
In-Process Volume [veh/h]	0	0	0	0	0	0	0	0	0	0	0	0
Site-Generated Trips [veh/h]	0	0	0	0	0	0	0	0	0	0	0	0
Diverted Trips [veh/h]	0	0	0	0	0	0	0	0	0	0	0	0
Pass-by Trips [veh/h]	0	0	0	0	0	0	0	0	0	0	0	0
Existing Site Adjustment Volume [veh/h]	0	0	0	0	0	0	0	0	0	0	0	0
Other Volume [veh/h]	0	0	0	0	0	0	0	0	0	0	0	0
Right Turn on Red Volume [veh/h]	0	0	0	0	0	0	0	0	0	0	0	0
Total Hourly Volume [veh/h]	0	932	131	0	239	641	0	0	0	51	0	680
Peak Hour Factor	1.0000	0.8700	0.8700	1.0000	0.8700	0.8700	1.0000	1.0000	1.0000	0.8700	0.8700	0.8700
Other Adjustment Factor	1.0000	1.0000	1.0000	1.0000	1.0000	1.0000	1.0000	1.0000	1.0000	1.0000	1.0000	1.0000
Total 15-Minute Volume [veh/h]	0	268	38	0	69	184	0	0	0	15	0	195
Total Analysis Volume [veh/h]	0	1071	151	0	275	737	0	0	0	59	0	782
Presence of On-Street Parking	No		No	No		No				No		No
On-Street Parking Maneuver Rate [/h]	0	0	0	0	0	0	0	0	0	0	0	0
Local Bus Stopping Rate [/h]	0	0	0	0	0	0	0	0	0	0	0	0
v_do, Outbound Pedestrian Volume crossing	0			0			0			0		
v_di, Inbound Pedestrian Volume crossing m	0			0			0			0		
v_co, Outbound Pedestrian Volume crossing	1			0			0			1		
v_ci, Inbound Pedestrian Volume crossing mi	1			0			0			1		
v_ab, Corner Pedestrian Volume [ped/h]	0			0			0			0		
Bicycle Volume [bicycles/h]	0			0			0			0		



**Intersection Settings**

Located in CBD	No
Signal Coordination Group	-
Cycle Length [s]	105
Active Pattern	Pattern 1
Coordination Type	Time of Day Pattern Coordinated
Actuation Type	Fully actuated
Offset [s]	91.0
Offset Reference	Lead Green - Beginning of First Green
Permissive Mode	SingleBand
Lost time [s]	9.00

**Phasing & Timing (Basic)**

Control Type	Permiss	Permiss	Unsigna	Permiss	Permiss	Unsigna	Permiss	Permiss	Permiss	Permiss	Permiss	Overlap
Signal Group	0	2	0	0	6	0	0	0	0	0	8	1
Auxiliary Signal Groups												1,8
Maximum Green [s]	0	30	0	0	25	0	0	0	0	0	20	12
Amber [s]	0.0	4.3	0.0	0.0	4.3	0.0	0.0	0.0	0.0	0.0	3.0	3.0
All red [s]	0.0	1.0	0.0	0.0	1.0	0.0	0.0	0.0	0.0	0.0	1.0	0.0
Walk [s]	0	7	0	0	0	0	0	0	0	0	0	0
Pedestrian Clearance [s]	0	15	0	0	0	0	0	0	0	0	0	0
Delayed Vehicle Green [s]	0.0	0.0	0.0	0.0	0.0	0.0	0.0	0.0	0.0	0.0	0.0	0.0
Rest In Walk		No			No						No	
I1, Start-Up Lost Time [s]	0.0	2.0	0.0	0.0	2.0	0.0	0.0	0.0	0.0	0.0	2.0	2.0
I2, Clearance Lost Time [s]	0.0	2.0	0.0	0.0	2.0	0.0	0.0	0.0	0.0	0.0	2.0	2.0
Detector Location [ft]	0.0	0.0	0.0	0.0	0.0	0.0	0.0	0.0	0.0	0.0	0.0	0.0
Detector Length [ft]	0.0	20.0	0.0	0.0	20.0	0.0	0.0	0.0	0.0	0.0	20.0	20.0
I, Upstream Filtering Factor	1.00	1.00	1.00	1.00	1.00	1.00	1.00	1.00	1.00	1.00	1.00	1.00

**Phasing & Timing: Pattern 1**

Split [s]	0	74	0	0	89	0	0	0	0	0	16	15
Lead / Lag	-	-	-	-	-	-	-	-	-	-	-	-
Minimum Green [s]	0	11	0	0	8	0	0	0	0	0	4	4
Vehicle Extension [s]	0.0	0.0	0.0	0.0	0.0	0.0	0.0	0.0	0.0	0.0	0.0	0.0
Minimum Recall		Yes			Yes						No	No
Maximum Recall		No			No						No	No
Pedestrian Recall		No			No						No	No

**Exclusive Pedestrian Phase**

Pedestrian Signal Group	0
Pedestrian Walk [s]	0
Pedestrian Clearance [s]	0



**Lane Group Calculations**

Lane Group	C	C		L	C	R
C, Cycle Length [s]	105	105		105	105	105
L, Total Lost Time per Cycle [s]	4.00	4.00		4.00	4.00	4.00
l1_p, Permitted Start-Up Lost Time [s]	0.00	0.00		0.00	0.00	0.00
l2, Clearance Lost Time [s]	2.00	2.00		2.00	2.00	0.00
g_i, Effective Green Time [s]	70	85		12	12	27
g / C, Green / Cycle	0.67	0.81		0.11	0.11	0.26
(v / s)_i Volume / Saturation Flow Rate	0.30	0.06		0.02	0.02	0.29
s, saturation flow rate [veh/h]	3535	4943		1749	1810	2667
c, Capacity [veh/h]	2355	4000		200	207	712
d1, Uniform Delay [s]	8.38	2.02		41.85	41.82	41.17
k, delay calibration	0.50	0.50		0.04	0.04	0.50
l, Upstream Filtering Factor	1.00	1.00		1.00	1.00	1.00
d2, Incremental Delay [s]	0.64	0.03		0.12	0.12	63.88
d3, Initial Queue Delay [s]	0.00	0.00		0.00	0.00	0.00
Rp, platoon ratio	1.00	1.00		1.00	1.00	1.00
PF, progression factor	1.00	1.00		1.00	1.00	1.00

**Lane Group Results**

X, volume / capacity	0.45	0.07		0.15	0.14	1.10
d, Delay for Lane Group [s/veh]	9.02	2.05		41.97	41.94	105.05
Lane Group LOS	A	A		D	D	F
Critical Lane Group	Yes	No		No	No	Yes
50th-Percentile Queue Length [veh/ln]	5.11	0.23		0.67	0.67	14.97
50th-Percentile Queue Length [ft/ln]	127.87	5.69		16.87	16.85	374.15
95th-Percentile Queue Length [veh/ln]	8.82	0.41		1.21	1.21	22.47
95th-Percentile Queue Length [ft/ln]	220.59	10.25		30.36	30.34	561.63

**Movement, Approach, & Intersection Results**

d_M, Delay for Movement [s/veh]	0.00	9.02	0.00	0.00	2.05	0.00	0.00	0.00	0.00	41.97	41.94	105.05
Movement LOS		A			A					D	D	F
d_A, Approach Delay [s/veh]	8.03				0.62				0.00		100.62	
Approach LOS	A				A				A		F	
d_I, Intersection Delay [s/veh]	42.71											
Intersection LOS	D											
Intersection V/C	0.482											

**Emissions**

Vehicle Miles Traveled [mph]	89.34	32.65	2.90	2.90	76.91
Stops [stops/h]	350.83	23.44	23.14	23.12	1026.53
Fuel consumption [US gal/h]	8.61	1.51	0.64	0.64	32.11
CO [g/h]	601.98	105.89	44.68	44.64	2244.79
NOx [g/h]	117.12	20.60	8.69	8.69	436.75
VOC [g/h]	139.51	24.54	10.35	10.35	520.25

**Other Modes**

g_Walk,mi, Effective Walk Time [s]	0.0	0.0	0.0	11.0
M_corner, Corner Circulation Area [ft <sup>2</sup> /ped]	0.00	0.00	0.00	0.00
M_CW, Crosswalk Circulation Area [ft <sup>2</sup> /ped]	0.00	0.00	0.00	0.00
d_p, Pedestrian Delay [s]	0.00	0.00	0.00	42.06
I_p,int, Pedestrian LOS Score for Intersectio	0.000	0.000	0.000	2.553
Crosswalk LOS	F	F	F	B
s_b, Saturation Flow Rate of the bicycle lane	2000	2000	2000	2000
c_b, Capacity of the bicycle lane [bicycles/h]	1309	1595	0	229
d_b, Bicycle Delay [s]	6.27	2.15	52.49	41.17
I_b,int, Bicycle LOS Score for Intersection	2.443	1.711	4.132	2.947
Bicycle LOS	B	A	D	C

**Sequence**

Ring 1	1	2	-	-	-	-	-	-	-	-	-	-	-	-	-
Ring 2	-	6	-	8	-	-	-	-	-	-	-	-	-	-	-
Ring 3	-	-	-	-	-	-	-	-	-	-	-	-	-	-	-
Ring 4	-	-	-	-	-	-	-	-	-	-	-	-	-	-	-



**Intersection Level Of Service Report**

**Intersection 18: Dublin Boulevard & Commercial Access Driveway**

Control Type:	Signalized	Delay (sec / veh):	33.8
Analysis Method:	HCM 7th Edition	Level Of Service:	C
Analysis Period:	15 minutes	Volume to Capacity (v/c):	0.647

**Intersection Setup**

Name	Project Access			Project Access			Dublin Boulevard			Dublin Boulevard		
Approach	Northbound			Southbound			Eastbound			Westbound		
Lane Configuration	⇐⇐⇐			⇐⇐⇐			⇐⇐⇐			⇐⇐⇐		
Turning Movement	Left	Thru	Right	Left	Thru	Right	Left	Thru	Right	Left	Thru	Right
Lane Width [ft]	12.00	12.00	12.00	12.00	12.00	12.00	12.00	12.00	12.00	12.00	12.00	12.00
No. of Lanes in Entry Pocket	1	0	0	1	0	1	1	0	1	1	0	0
Entry Pocket Length [ft]	100.00	100.00	100.00	100.00	100.00	100.00	100.00	100.00	100.00	100.00	100.00	100.00
No. of Lanes in Exit Pocket	0	0	0	0	0	0	0	0	0	0	0	0
Exit Pocket Length [ft]	0.00	0.00	0.00	0.00	0.00	0.00	0.00	0.00	0.00	0.00	0.00	0.00
Speed [mph]	30.00			30.00			30.00			45.00		
Grade [%]	0.00			0.00			0.00			0.00		
Curb Present	No			No			No			No		
Crosswalk	Yes			Yes			Yes			Yes		



**Volumes**

Name	Project Access			Project Access			Dublin Boulevard			Dublin Boulevard		
Base Volume Input [veh/h]	92	3	0	11	3	29	157	561	556	0	1618	71
Base Volume Adjustment Factor	1.0000	1.0000	1.0000	1.0000	1.0000	1.0000	1.0000	1.0000	1.0000	1.0000	1.0000	1.0000
Heavy Vehicles Percentage [%]	2.00	2.00	2.00	2.00	2.00	2.00	2.00	2.00	2.00	2.00	2.00	2.00
Proportion of CAVs [%]	0.00											
Growth Factor	1.0000	1.0000	1.0000	1.0000	1.0000	1.0000	1.0000	1.0000	1.0000	1.0000	1.0000	1.0000
In-Process Volume [veh/h]	0	0	0	0	0	0	0	0	0	0	0	0
Site-Generated Trips [veh/h]	0	0	0	0	0	0	0	0	0	0	0	0
Diverted Trips [veh/h]	0	0	0	0	0	0	0	0	0	0	0	0
Pass-by Trips [veh/h]	0	0	0	0	0	0	0	0	0	0	0	0
Existing Site Adjustment Volume [veh/h]	0	0	0	0	0	0	0	0	0	0	0	0
Other Volume [veh/h]	0	0	0	0	0	0	0	0	0	0	0	0
Right Turn on Red Volume [veh/h]	0	0	0	0	0	0	0	0	0	0	0	0
Total Hourly Volume [veh/h]	92	3	0	11	3	29	157	561	556	0	1618	71
Peak Hour Factor	1.0000	1.0000	1.0000	1.0000	1.0000	1.0000	1.0000	1.0000	1.0000	1.0000	1.0000	1.0000
Other Adjustment Factor	1.0000	1.0000	1.0000	1.0000	1.0000	1.0000	1.0000	1.0000	1.0000	1.0000	1.0000	1.0000
Total 15-Minute Volume [veh/h]	23	1	0	3	1	7	39	140	139	0	405	18
Total Analysis Volume [veh/h]	92	3	0	11	3	29	157	561	556	0	1618	71
Presence of On-Street Parking	No		No	No		No	No		No	No		No
On-Street Parking Maneuver Rate [/h]	0	0	0	0	0	0	0	0	0	0	0	0
Local Bus Stopping Rate [/h]	0	0	0	0	0	0	0	0	0	0	0	0
v_do, Outbound Pedestrian Volume crossing	0			0			0			0		
v_di, Inbound Pedestrian Volume crossing m	0			0			0			0		
v_co, Outbound Pedestrian Volume crossing	0			0			0			0		
v_ci, Inbound Pedestrian Volume crossing mi	0			0			0			0		
v_ab, Corner Pedestrian Volume [ped/h]	0			0			0			0		
Bicycle Volume [bicycles/h]	0			0			0			0		



**Intersection Settings**

Located in CBD	No
Signal Coordination Group	-
Cycle Length [s]	135
Active Pattern	Pattern 1
Coordination Type	Time of Day Pattern Isolated
Actuation Type	Fully actuated
Offset [s]	0.0
Offset Reference	Lead Green - Beginning of First Green
Permissive Mode	SingleBand
Lost time [s]	12.00

**Phasing & Timing (Basic)**

Control Type	Protecte	Permiss	Permiss	Protecte	Permiss	Permiss	Protecte	Permiss	Permiss	Protecte	Permiss	Permiss
Signal Group	1	6	0	5	2	0	3	8	0	7	4	0
Auxiliary Signal Groups												
Maximum Green [s]	5	29	0	5	29	0	5	123	0	5	123	0
Amber [s]	3.0	3.0	0.0	3.0	3.0	0.0	3.0	3.0	0.0	3.0	3.0	0.0
All red [s]	1.0	1.0	0.0	1.0	1.0	0.0	1.0	1.0	0.0	1.0	1.0	0.0
Walk [s]	0	5	0	0	5	0	0	5	0	0	5	0
Pedestrian Clearance [s]	0	21	0	0	24	0	0	7	0	0	7	0
Delayed Vehicle Green [s]	0.0	0.0	0.0	0.0	0.0	0.0	0.0	0.0	0.0	0.0	0.0	0.0
Rest In Walk		No			No			No			No	
I1, Start-Up Lost Time [s]	2.0	2.0	0.0	2.0	2.0	0.0	2.0	2.0	0.0	2.0	2.0	0.0
I2, Clearance Lost Time [s]	2.0	2.0	0.0	2.0	2.0	0.0	2.0	2.0	0.0	2.0	2.0	0.0
Detector Location [ft]	0.0	0.0	0.0	0.0	0.0	0.0	0.0	0.0	0.0	0.0	0.0	0.0
Detector Length [ft]	20.0	20.0	0.0	20.0	20.0	0.0	20.0	20.0	0.0	20.0	20.0	0.0
I, Upstream Filtering Factor	1.00	1.00	1.00	1.00	1.00	1.00	1.00	1.00	1.00	1.00	1.00	1.00

**Phasing & Timing: Pattern 1**

Split [s]	9	33	0	9	33	0	19	84	0	9	74	0
Lead / Lag	Lead	-	-	Lead	-	-	Lead	-	-	Lead	-	-
Minimum Green [s]	5	10	0	5	10	0	5	10	0	5	10	0
Vehicle Extension [s]	3.0	3.0	0.0	3.0	3.0	0.0	3.0	3.0	0.0	3.0	3.0	0.0
Minimum Recall	No	No		No	No		No	No		No	No	
Maximum Recall	No	No		No	No		No	No		No	No	
Pedestrian Recall	No	No		No	No		No	No		No	No	

**Exclusive Pedestrian Phase**

Pedestrian Signal Group	0
Pedestrian Walk [s]	0
Pedestrian Clearance [s]	0





**Lane Group Calculations**

Lane Group	L	C	L	C	R	L	C	R	L	C	C
C, Cycle Length [s]	135	135	135	135	135	135	135	135	135	135	135
L, Total Lost Time per Cycle [s]	4.00	4.00	4.00	4.00	4.00	4.00	4.00	4.00	4.00	4.00	4.00
l1_p, Permitted Start-Up Lost Time [s]	0.00	0.00	0.00	0.00	0.00	0.00	0.00	0.00	0.00	0.00	0.00
l2, Clearance Lost Time [s]	2.00	2.00	2.00	2.00	2.00	2.00	2.00	2.00	2.00	2.00	2.00
g_i, Effective Green Time [s]	5	38	2	35	35	14	79	79	0	65	65
g / C, Green / Cycle	0.04	0.28	0.01	0.26	0.26	0.10	0.59	0.59	0.00	0.48	0.48
(v / s)_i Volume / Saturation Flow Rate	0.03	0.00	0.01	0.00	0.02	0.09	0.16	0.35	0.00	0.45	0.46
s, saturation flow rate [veh/h]	3459	1870	1781	1870	1589	1781	3560	1589	1781	1870	1843
c, Capacity [veh/h]	128	528	23	483	410	181	2088	932	0	907	894
d1, Uniform Delay [s]	64.39	34.86	66.29	37.26	37.89	59.82	13.72	17.78	0.00	32.78	33.00
k, delay calibration	0.11	0.50	0.11	0.50	0.50	0.27	0.11	0.11	0.11	0.11	0.11
l, Upstream Filtering Factor	1.00	1.00	1.00	1.00	1.00	1.00	1.00	1.00	1.00	1.00	1.00
d2, Incremental Delay [s]	7.35	0.02	15.32	0.02	0.33	24.52	0.07	0.61	0.00	5.19	5.78
d3, Initial Queue Delay [s]	0.00	0.00	0.00	0.00	0.00	0.00	0.00	0.00	0.00	0.00	0.00
Rp, platoon ratio	1.00	1.00	1.00	1.00	1.00	1.00	1.00	1.00	1.00	1.00	1.00
PF, progression factor	1.00	1.00	1.00	1.00	1.00	1.00	1.00	1.00	1.00	1.00	1.00

**Lane Group Results**

X, volume / capacity	0.72	0.01	0.49	0.01	0.07	0.87	0.27	0.60	0.00	0.93	0.94
d, Delay for Lane Group [s/veh]	71.74	34.88	81.61	37.29	38.23	84.34	13.79	18.39	0.00	37.98	38.78
Lane Group LOS	E	C	F	D	D	F	B	B	A	D	D
Critical Lane Group	Yes	No	No	No	Yes	Yes	No	No	No	No	Yes
50th-Percentile Queue Length [veh/ln]	1.70	0.08	0.47	0.08	0.77	6.54	4.23	10.97	0.00	25.75	25.88
50th-Percentile Queue Length [ft/ln]	42.55	1.88	11.86	1.95	19.37	163.48	105.73	274.24	0.00	643.84	646.89
95th-Percentile Queue Length [veh/ln]	3.06	0.14	0.85	0.14	1.39	10.73	7.60	16.40	0.00	34.08	34.22
95th-Percentile Queue Length [ft/ln]	76.59	3.38	21.34	3.51	34.87	268.33	190.04	410.03	0.00	851.91	855.45



**Movement, Approach, & Intersection Results**

d_M, Delay for Movement [s/veh]	71.74	34.88	34.88	81.61	37.29	38.23	84.34	13.79	18.39	0.00	38.36	38.78
Movement LOS	E	C	C	F	D	D	F	B	B	A	D	D
d_A, Approach Delay [s/veh]	70.58			49.26			24.49			38.38		
Approach LOS	E			D			C			D		
d_I, Intersection Delay [s/veh]	33.81											
Intersection LOS	C											
Intersection V/C	0.647											

**Emissions**

Vehicle Miles Traveled [mph]	7.34	0.24	0.50	0.14	1.31	35.23	125.89	124.77	0.00	261.20	259.43
Stops [stops/h]	90.72	2.00	12.64	2.08	20.65	174.27	225.41	292.34	0.00	686.34	689.59
Fuel consumption [US gal/h]	2.15	0.04	0.27	0.04	0.39	5.11	8.00	8.83	0.00	24.04	24.11
CO [g/h]	150.02	2.95	19.08	2.78	27.51	357.01	559.36	617.41	0.00	1680.09	1685.17
NOx [g/h]	29.19	0.57	3.71	0.54	5.35	69.46	108.83	120.12	0.00	326.88	327.87
VOC [g/h]	34.77	0.68	4.42	0.65	6.38	82.74	129.64	143.09	0.00	389.38	390.55

**Other Modes**

g_Walk,mi, Effective Walk Time [s]	9.0	9.0	9.0	9.0
M_corner, Corner Circulation Area [ft <sup>2</sup> /ped]	0.00	0.00	0.00	0.00
M_CW, Crosswalk Circulation Area [ft <sup>2</sup> /ped]	0.00	0.00	0.00	0.00
d_p, Pedestrian Delay [s]	58.84	58.84	58.84	58.84
I_p,int, Pedestrian LOS Score for Intersectio	2.311	2.219	3.113	2.982
Crosswalk LOS	B	B	C	C
s_b, Saturation Flow Rate of the bicycle lane	2000	2000	2000	2000
c_b, Capacity of the bicycle lane [bicycles/h]	429	429	1184	1036
d_b, Bicycle Delay [s]	41.65	41.65	11.23	15.68
I_b,int, Bicycle LOS Score for Intersection	1.716	1.631	2.611	2.953
Bicycle LOS	A	A	B	C

**Sequence**

Ring 1	1	2	3	4	-	-	-	-	-	-	-	-	-	-	-
Ring 2	5	6	7	8	-	-	-	-	-	-	-	-	-	-	-
Ring 3	-	-	-	-	-	-	-	-	-	-	-	-	-	-	-
Ring 4	-	-	-	-	-	-	-	-	-	-	-	-	-	-	-



**Intersection Level Of Service Report**

**Intersection 19: Pandora Way & Residential Project Access Driveway (Parcel 7)**

Control Type:	All-way stop	Delay (sec / veh):	7.1
Analysis Method:	HCM 7th Edition	Level Of Service:	A
Analysis Period:	15 minutes	Volume to Capacity (v/c):	0.060

**Intersection Setup**

Name	Residential Project Access (Parcel 7)		Pino Grande Road		Pandora Way	
Approach	Northbound		Southbound		Westbound	
Lane Configuration	↬		↵		↶	
Turning Movement	Thru	Right	Left	Thru	Left	Right
Lane Width [ft]	12.00	12.00	12.00	12.00	12.00	12.00
No. of Lanes in Entry Pocket	0	0	0	0	0	0
Entry Pocket Length [ft]	100.00	100.00	100.00	100.00	100.00	100.00
No. of Lanes in Exit Pocket	0	0	0	0	0	0
Exit Pocket Length [ft]	0.00	0.00	0.00	0.00	0.00	0.00
Speed [mph]	30.00		30.00		30.00	
Grade [%]	0.00		0.00		0.00	
Crosswalk	Yes		Yes		Yes	

**Volumes**

Name	Residential Project Access (Parcel 7)		Pino Grande Road		Pandora Way	
Base Volume Input [veh/h]	55	0	5	0	0	5
Base Volume Adjustment Factor	1.0000	1.0000	1.0000	1.0000	1.0000	1.0000
Heavy Vehicles Percentage [%]	2.00	2.00	2.00	2.00	2.00	2.00
Growth Factor	1.0000	1.0000	1.0000	1.0000	1.0000	1.0000
In-Process Volume [veh/h]	0	0	0	0	0	0
Site-Generated Trips [veh/h]	0	0	0	0	0	0
Diverted Trips [veh/h]	0	0	0	0	0	0
Pass-by Trips [veh/h]	0	0	0	0	0	0
Existing Site Adjustment Volume [veh/h]	0	0	0	0	0	0
Other Volume [veh/h]	0	0	0	0	0	0
Total Hourly Volume [veh/h]	55	0	5	0	0	5
Peak Hour Factor	1.0000	1.0000	1.0000	1.0000	1.0000	1.0000
Other Adjustment Factor	1.0000	1.0000	1.0000	1.0000	1.0000	1.0000
Total 15-Minute Volume [veh/h]	14	0	1	0	0	1
Total Analysis Volume [veh/h]	55	0	5	0	0	5
Pedestrian Volume [ped/h]	0		0		0	



**Intersection Settings****Lanes**

Capacity per Entry Lane [veh/h]	912	858	1041
Degree of Utilization, x	0.06	0.01	0.00

**Movement, Approach, & Intersection Results**

95th-Percentile Queue Length [veh]	0.19	0.02	0.01
95th-Percentile Queue Length [ft]	4.81	0.44	0.36
Approach Delay [s/veh]	7.20	7.22	6.48
Approach LOS	A	A	A
Intersection Delay [s/veh]	7.15		
Intersection LOS	A		

**Intersection Level Of Service Report**  
**Intersection 20: Croak Road & Central Parkway**

Control Type:	All-way stop	Delay (sec / veh):	11.8
Analysis Method:	HCM 7th Edition	Level Of Service:	B
Analysis Period:	15 minutes	Volume to Capacity (v/c):	0.514

**Intersection Setup**

Name	Croak Road			Croak Road			Central Parkway					
Approach	Northbound			Southbound			Eastbound			Westbound		
Lane Configuration	+			+			+			+		
Turning Movement	Left	Thru	Right	Left	Thru	Right	Left	Thru	Right	Left	Thru	Right
Lane Width [ft]	12.00	12.00	12.00	12.00	12.00	12.00	12.00	12.00	12.00	12.00	12.00	12.00
No. of Lanes in Entry Pocket	0	0	0	0	0	0	0	0	0	0	0	0
Entry Pocket Length [ft]	100.00	100.00	100.00	100.00	100.00	100.00	100.00	100.00	100.00	100.00	100.00	100.00
No. of Lanes in Exit Pocket	0	0	0	0	0	0	0	0	0	0	0	0
Exit Pocket Length [ft]	0.00	0.00	0.00	0.00	0.00	0.00	0.00	0.00	0.00	0.00	0.00	0.00
Speed [mph]	30.00			30.00			25.00			30.00		
Grade [%]	0.00			0.00			0.00			0.00		
Crosswalk	Yes			Yes			Yes			Yes		

**Volumes**

Name	Croak Road			Croak Road			Central Parkway					
Base Volume Input [veh/h]	27	36	9	0	117	143	51	246	69	27	152	0
Base Volume Adjustment Factor	1.0000	1.0000	1.0000	1.0000	1.0000	1.0000	1.0000	1.0000	1.0000	1.0000	1.0000	1.0000
Heavy Vehicles Percentage [%]	2.00	2.00	2.00	2.00	2.00	2.00	2.00	2.00	2.00	2.00	2.00	2.00
Growth Factor	1.0000	1.0000	1.0000	1.0000	1.0000	1.0000	1.0000	1.0000	1.0000	1.0000	1.0000	1.0000
In-Process Volume [veh/h]	0	0	0	0	0	0	0	0	0	0	0	0
Site-Generated Trips [veh/h]	0	0	0	0	0	0	0	0	0	0	0	0
Diverted Trips [veh/h]	0	0	0	0	0	0	0	0	0	0	0	0
Pass-by Trips [veh/h]	0	0	0	0	0	0	0	0	0	0	0	0
Existing Site Adjustment Volume [veh/h]	0	0	0	0	0	0	0	0	0	0	0	0
Other Volume [veh/h]	0	0	0	0	0	0	0	0	0	0	0	0
Total Hourly Volume [veh/h]	27	36	9	0	117	143	51	246	69	27	152	0
Peak Hour Factor	1.0000	1.0000	1.0000	1.0000	1.0000	1.0000	1.0000	1.0000	1.0000	1.0000	1.0000	1.0000
Other Adjustment Factor	1.0000	1.0000	1.0000	1.0000	1.0000	1.0000	1.0000	1.0000	1.0000	1.0000	1.0000	1.0000
Total 15-Minute Volume [veh/h]	7	9	2	0	29	36	13	62	17	7	38	0
Total Analysis Volume [veh/h]	27	36	9	0	117	143	51	246	69	27	152	0
Pedestrian Volume [ped/h]	0			0			0			0		



**Intersection Settings****Lanes**

Capacity per Entry Lane [veh/h]	617	696	712	662
Degree of Utilization, x	0.12	0.37	0.51	0.27

**Movement, Approach, & Intersection Results**

95th-Percentile Queue Length [veh]	0.39	1.73	2.97	1.09
95th-Percentile Queue Length [ft]	9.86	43.34	74.21	27.29
Approach Delay [s/veh]	9.61	11.22	13.28	10.44
Approach LOS	A	B	B	B
Intersection Delay [s/veh]	11.79			
Intersection LOS	B			

**Intersection Level Of Service Report**  
**Intersection 21: Croak Road & Project Access (Parcel 8)**

Control Type:	Two-way stop	Delay (sec / veh):	10.4
Analysis Method:	HCM 7th Edition	Level Of Service:	B
Analysis Period:	15 minutes	Volume to Capacity (v/c):	0.057

**Intersection Setup**

Name	Croak Road		Croak Road		Project Access (Parcel 8)	
Approach	Northbound		Southbound		Westbound	
Lane Configuration	↩		↪		↔	
Turning Movement	Thru	Right	Left	Thru	Left	Right
Lane Width [ft]	12.00	12.00	12.00	12.00	12.00	12.00
No. of Lanes in Entry Pocket	0	0	0	0	0	0
Entry Pocket Length [ft]	100.00	100.00	100.00	100.00	100.00	100.00
No. of Lanes in Exit Pocket	0	0	0	0	0	0
Exit Pocket Length [ft]	0.00	0.00	0.00	0.00	0.00	0.00
Speed [mph]	30.00		30.00		30.00	
Grade [%]	0.00		0.00		0.00	
Crosswalk	Yes		Yes		Yes	

**Volumes**

Name	Croak Road		Croak Road		Project Access (Parcel 8)	
Base Volume Input [veh/h]	67	5	2	211	40	4
Base Volume Adjustment Factor	1.0000	1.0000	1.0000	1.0000	1.0000	1.0000
Heavy Vehicles Percentage [%]	2.00	2.00	2.00	2.00	2.00	2.00
Growth Factor	1.0000	1.0000	1.0000	1.0000	1.0000	1.0000
In-Process Volume [veh/h]	0	0	0	0	0	0
Site-Generated Trips [veh/h]	0	0	0	0	0	0
Diverted Trips [veh/h]	0	0	0	0	0	0
Pass-by Trips [veh/h]	0	0	0	0	0	0
Existing Site Adjustment Volume [veh/h]	0	0	0	0	0	0
Other Volume [veh/h]	0	0	0	0	0	0
Total Hourly Volume [veh/h]	67	5	2	211	40	4
Peak Hour Factor	1.0000	1.0000	1.0000	1.0000	1.0000	1.0000
Other Adjustment Factor	1.0000	1.0000	1.0000	1.0000	1.0000	1.0000
Total 15-Minute Volume [veh/h]	17	1	1	53	10	1
Total Analysis Volume [veh/h]	67	5	2	211	40	4
Pedestrian Volume [ped/h]	0		0		0	



**Intersection Settings**

Priority Scheme	Free	Free	Stop
Flared Lane			No
Storage Area [veh]	0	0	0
Two-Stage Gap Acceptance			No
Number of Storage Spaces in Median	0	0	0

**Movement, Approach, & Intersection Results**

V/C, Movement V/C Ratio	0.00	0.00	0.00	0.00	0.06	0.00
d_M, Delay for Movement [s/veh]	0.00	0.00	7.36	0.00	10.43	8.95
Movement LOS	A	A	A	A	B	A
95th-Percentile Queue Length [veh/ln]	0.00	0.00	0.00	0.00	0.19	0.19
95th-Percentile Queue Length [ft/ln]	0.00	0.00	0.08	0.08	4.84	4.84
d_A, Approach Delay [s/veh]	0.00		0.07		10.30	
Approach LOS	A		A		B	
d_I, Intersection Delay [s/veh]	1.42					
Intersection LOS	B					





**Intersection Level Of Service Report**  
**Intersection 22: Croak Road & Dublin Boulevard**

Control Type:	Signalized	Delay (sec / veh):	36.0
Analysis Method:	HCM 7th Edition	Level Of Service:	D
Analysis Period:	15 minutes	Volume to Capacity (v/c):	0.649

**Intersection Setup**

Name	Croak Road			Croak Road			Dublin Boulevard			Dublin Boulevard		
Approach	Northbound			Southbound			Eastbound			Westbound		
Lane Configuration												
Turning Movement	Left	Thru	Right	Left	Thru	Right	Left	Thru	Right	Left	Thru	Right
Lane Width [ft]	12.00	12.00	12.00	12.00	12.00	12.00	12.00	12.00	12.00	12.00	12.00	12.00
No. of Lanes in Entry Pocket	1	0	0	1	0	1	1	0	1	1	0	1
Entry Pocket Length [ft]	100.00	100.00	100.00	100.00	100.00	100.00	210.00	100.00	250.00	150.00	100.00	250.00
No. of Lanes in Exit Pocket	0	0	0	0	0	0	0	0	1	0	0	0
Exit Pocket Length [ft]	0.00	0.00	0.00	0.00	0.00	0.00	0.00	0.00	49.21	0.00	0.00	0.00
Speed [mph]	30.00			30.00			30.00			30.00		
Grade [%]	0.00			0.00			0.00			0.00		
Curb Present	No			No			No			No		
Crosswalk	Yes			Yes			Yes			Yes		



**Volumes**

Name	Croak Road			Croak Road			Dublin Boulevard			Dublin Boulevard		
Base Volume Input [veh/h]	25	4	46	67	8	55	117	325	130	299	1609	78
Base Volume Adjustment Factor	1.0000	1.0000	1.0000	1.0000	1.0000	1.0000	1.0000	1.0000	1.0000	1.0000	1.0000	1.0000
Heavy Vehicles Percentage [%]	2.00	2.00	2.00	2.00	2.00	2.00	2.00	2.00	2.00	2.00	2.00	2.00
Proportion of CAVs [%]	0.00											
Growth Factor	1.0000	1.0000	1.0000	1.0000	1.0000	1.0000	1.0000	1.0000	1.0000	1.0000	1.0000	1.0000
In-Process Volume [veh/h]	0	0	0	0	0	0	0	0	0	0	0	0
Site-Generated Trips [veh/h]	0	0	0	0	0	0	0	0	0	0	0	0
Diverted Trips [veh/h]	0	0	0	0	0	0	0	0	0	0	0	0
Pass-by Trips [veh/h]	0	0	0	0	0	0	0	0	0	0	0	0
Existing Site Adjustment Volume [veh/h]	0	0	0	0	0	0	0	0	0	0	0	0
Other Volume [veh/h]	0	0	0	0	0	0	0	0	0	0	0	0
Right Turn on Red Volume [veh/h]	0	0	0	0	0	0	0	0	0	0	0	0
Total Hourly Volume [veh/h]	25	4	46	67	8	55	117	325	130	299	1609	78
Peak Hour Factor	1.0000	1.0000	1.0000	1.0000	1.0000	1.0000	1.0000	1.0000	1.0000	1.0000	1.0000	1.0000
Other Adjustment Factor	1.0000	1.0000	1.0000	1.0000	1.0000	1.0000	1.0000	1.0000	1.0000	1.0000	1.0000	1.0000
Total 15-Minute Volume [veh/h]	6	1	12	17	2	14	29	81	33	75	402	20
Total Analysis Volume [veh/h]	25	4	46	67	8	55	117	325	130	299	1609	78
Presence of On-Street Parking	No		No	No		No	No		No	No		No
On-Street Parking Maneuver Rate [/h]	0	0	0	0	0	0	0	0	0	0	0	0
Local Bus Stopping Rate [/h]	0	0	0	0	0	0	0	0	0	0	0	0
v_do, Outbound Pedestrian Volume crossing	0			0			0			0		
v_di, Inbound Pedestrian Volume crossing m	0			0			0			0		
v_co, Outbound Pedestrian Volume crossing	0			0			0			0		
v_ci, Inbound Pedestrian Volume crossing mi	0			0			0			0		
v_ab, Corner Pedestrian Volume [ped/h]	0			0			0			0		
Bicycle Volume [bicycles/h]	0			0			0			0		



**Intersection Settings**

Located in CBD	No
Signal Coordination Group	-
Cycle Length [s]	125
Active Pattern	Pattern 1
Coordination Type	Time of Day Pattern Isolated
Actuation Type	Fully actuated
Offset [s]	0.0
Offset Reference	Lead Green - Beginning of First Green
Permissive Mode	SingleBand
Lost time [s]	12.00

**Phasing & Timing (Basic)**

Control Type	Protecte	Permiss	Permiss	Protecte	Permiss	Permiss	Protecte	Permiss	Permiss	Protecte	Permiss	Permiss
Signal Group	1	6	0	5	2	0	3	8	0	7	4	0
Auxiliary Signal Groups												
Maximum Green [s]	5	26	0	5	26	0	5	126	0	5	126	0
Amber [s]	3.0	3.0	0.0	3.0	3.0	0.0	3.0	3.0	0.0	3.0	3.0	0.0
All red [s]	1.0	1.0	0.0	1.0	1.0	0.0	1.0	1.0	0.0	1.0	1.0	0.0
Walk [s]	0	5	0	0	5	0	0	5	0	0	5	0
Pedestrian Clearance [s]	0	21	0	0	21	0	0	10	0	0	10	0
Delayed Vehicle Green [s]	0.0	0.0	0.0	0.0	0.0	0.0	0.0	0.0	0.0	0.0	0.0	0.0
Rest In Walk		No			No			No			No	
I1, Start-Up Lost Time [s]	2.0	2.0	0.0	2.0	2.0	0.0	2.0	2.0	0.0	2.0	2.0	0.0
I2, Clearance Lost Time [s]	2.0	2.0	0.0	2.0	2.0	0.0	2.0	2.0	0.0	2.0	2.0	0.0
Detector Location [ft]	0.0	0.0	0.0	0.0	0.0	0.0	0.0	0.0	0.0	0.0	0.0	0.0
Detector Length [ft]	20.0	20.0	0.0	0.0	0.0	0.0	20.0	20.0	0.0	20.0	20.0	0.0
I, Upstream Filtering Factor	1.00	1.00	1.00	1.00	1.00	1.00	1.00	1.00	1.00	1.00	1.00	1.00

**Phasing & Timing: Pattern 1**

Split [s]	10	30	0	10	30	0	14	35	0	50	71	0
Lead / Lag	Lead	-	-	Lead	-	-	Lead	-	-	Lead	-	-
Minimum Green [s]	5	10	0	5	10	0	5	10	0	5	10	0
Vehicle Extension [s]	3.0	3.0	0.0	3.0	3.0	0.0	3.0	3.0	0.0	3.0	3.0	0.0
Minimum Recall	No	No		No	No		No	No		No	No	
Maximum Recall	No	No		No	No		No	No		No	No	
Pedestrian Recall	No	No		No	No		No	No		No	No	

**Exclusive Pedestrian Phase**

Pedestrian Signal Group	0
Pedestrian Walk [s]	0
Pedestrian Clearance [s]	0



**Lane Group Calculations**

Lane Group	L	C	L	C	R	L	C	R	L	C	R
C, Cycle Length [s]	125	125	125	125	125	125	125	125	125	125	125
L, Total Lost Time per Cycle [s]	4.00	4.00	4.00	4.00	4.00	4.00	4.00	4.00	4.00	4.00	4.00
l1_p, Permitted Start-Up Lost Time [s]	0.00	0.00	0.00	0.00	0.00	0.00	0.00	0.00	0.00	0.00	0.00
l2, Clearance Lost Time [s]	2.00	2.00	2.00	2.00	2.00	2.00	2.00	2.00	2.00	2.00	2.00
g_i, Effective Green Time [s]	3	30	6	33	33	10	49	49	23	63	63
g / C, Green / Cycle	0.02	0.24	0.05	0.27	0.27	0.08	0.40	0.40	0.19	0.50	0.50
(v / s)_i Volume / Saturation Flow Rate	0.01	0.03	0.04	0.00	0.03	0.07	0.09	0.08	0.17	0.45	0.05
s, saturation flow rate [veh/h]	1781	1609	1781	1870	1589	1781	3560	1589	1781	3560	1589
c, Capacity [veh/h]	41	390	85	499	424	141	1408	629	332	1789	799
d1, Uniform Delay [s]	60.49	37.05	58.87	33.74	34.80	56.71	25.14	24.88	49.73	28.23	16.27
k, delay calibration	0.11	0.50	0.18	0.50	0.50	0.25	0.11	0.11	0.11	0.11	0.11
l, Upstream Filtering Factor	1.00	1.00	1.00	1.00	1.00	1.00	1.00	1.00	1.00	1.00	1.00
d2, Incremental Delay [s]	13.33	0.68	22.05	0.06	0.63	23.65	0.08	0.16	8.86	1.87	0.05
d3, Initial Queue Delay [s]	0.00	0.00	0.00	0.00	0.00	0.00	0.00	0.00	0.00	0.00	0.00
Rp, platoon ratio	1.00	1.00	1.00	1.00	1.00	1.00	1.00	1.00	1.00	1.00	1.00
PF, progression factor	1.00	1.00	1.00	1.00	1.00	1.00	1.00	1.00	1.00	1.00	1.00

**Lane Group Results**

X, volume / capacity	0.60	0.13	0.78	0.02	0.13	0.83	0.23	0.21	0.90	0.90	0.10
d, Delay for Lane Group [s/veh]	73.82	37.73	80.93	33.80	35.43	80.35	25.23	25.04	58.58	30.10	16.33
Lane Group LOS	E	D	F	C	D	F	C	C	E	C	B
Critical Lane Group	No	Yes	Yes	No	No	Yes	No	No	No	Yes	No
50th-Percentile Queue Length [veh/ln]	0.94	1.28	2.62	0.19	1.36	4.57	3.26	2.59	9.93	21.59	1.19
50th-Percentile Queue Length [ft/ln]	23.51	32.07	65.61	4.74	34.01	114.28	81.43	64.86	248.19	539.79	29.81
95th-Percentile Queue Length [veh/ln]	1.69	2.31	4.72	0.34	2.45	8.08	5.86	4.67	15.09	29.21	2.15
95th-Percentile Queue Length [ft/ln]	42.31	57.72	118.09	8.53	61.21	201.93	146.58	116.74	377.37	730.30	53.66



**Movement, Approach, & Intersection Results**

d_M, Delay for Movement [s/veh]	73.82	37.73	37.73	80.93	33.80	35.43	80.35	25.23	25.04	58.58	30.10	16.33
Movement LOS	E	D	D	F	C	D	F	C	C	E	C	B
d_A, Approach Delay [s/veh]	49.76			58.78			36.46			33.85		
Approach LOS	D			E			D			C		
d_I, Intersection Delay [s/veh]	35.99											
Intersection LOS	D											
Intersection V/C	0.649											

**Emissions**

Vehicle Miles Traveled [mph]	2.14	4.28	15.78	1.88	12.96	36.06	100.18	40.07	7.10	38.19	1.85
Stops [stops/h]	27.08	36.94	75.57	5.46	39.17	131.63	187.60	74.71	285.88	1243.54	34.34
Fuel consumption [US gal/h]	0.61	0.76	2.17	0.16	1.15	4.12	6.83	2.72	5.44	18.30	0.53
CO [g/h]	42.86	53.40	151.72	11.38	80.13	288.32	477.33	190.47	379.97	1278.98	36.70
NOx [g/h]	8.34	10.39	29.52	2.21	15.59	56.10	92.87	37.06	73.93	248.84	7.14
VOC [g/h]	9.93	12.38	35.16	2.64	18.57	66.82	110.63	44.14	88.06	296.42	8.51

**Other Modes**

g_Walk,mi, Effective Walk Time [s]	9.0	9.0	9.0	9.0
M_corner, Corner Circulation Area [ft <sup>2</sup> /ped]	0.00	0.00	0.00	0.00
M_CW, Crosswalk Circulation Area [ft <sup>2</sup> /ped]	0.00	0.00	0.00	0.00
d_p, Pedestrian Delay [s]	53.83	53.83	53.83	53.83
I_p,int, Pedestrian LOS Score for Intersectio	2.124	2.228	2.926	2.864
Crosswalk LOS	B	B	C	C
s_b, Saturation Flow Rate of the bicycle lane	2000	2000	2000	2000
c_b, Capacity of the bicycle lane [bicycles/h]	416	416	496	1072
d_b, Bicycle Delay [s]	39.21	39.21	35.35	13.46
I_b,int, Bicycle LOS Score for Intersection	1.683	1.774	2.032	3.198
Bicycle LOS	A	A	B	C

**Sequence**

Ring 1	1	2	3	4	-	-	-	-	-	-	-	-	-	-	-
Ring 2	5	6	7	8	-	-	-	-	-	-	-	-	-	-	-
Ring 3	-	-	-	-	-	-	-	-	-	-	-	-	-	-	-
Ring 4	-	-	-	-	-	-	-	-	-	-	-	-	-	-	-

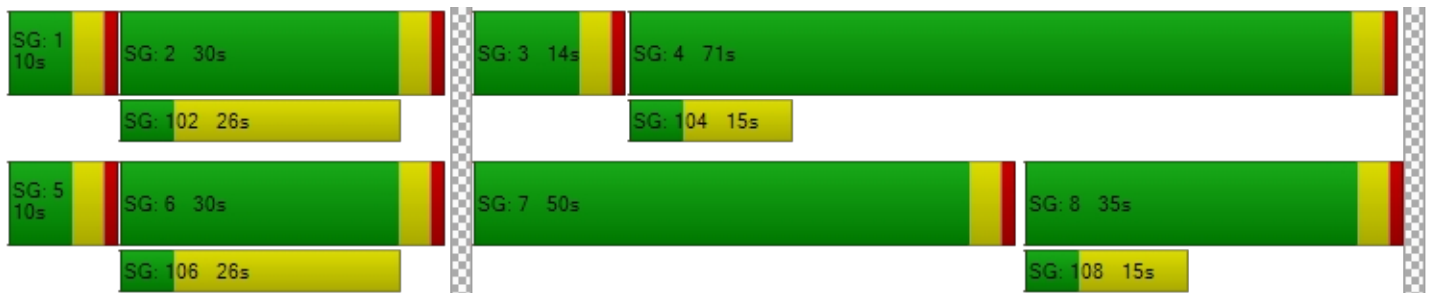

Vistro File: H:\...\PacVest\_20240329.vistro  
 Report File: H:\...\CumulativePM\_PP\_LOS.pdf

Scenario 12 Cumulative PM Plus Project  
 3/29/2024

**Intersection Analysis Summary**

ID	Intersection Name	Control Type	Method	Worst Mvmt	V/C	Delay (s/veh)	LOS
1	Hacienda Drive & Dublin Boulevard	Signalized	HCM 7th Edition	EB Left	0.679	44.5	D
2	Tassajara Road & Central Parkway	Signalized	HCM 7th Edition	EB Thru	0.762	45.1	D
3	Tassajara Road & Dublin Boulevard	Signalized	HCM 7th Edition	NB Right	1.330	133.1	F
4	Tassajara Road & I-580 WB Ramps	Signalized	HCM 7th Edition	WB Left	0.822	16.7	B
5	Santa Rita Rd & I-580 EB Ramps/Pimlico Dr	Signalized	HCM 7th Edition	SB Left	0.968	45.6	D
6	Tassajara Road & Fallon Road	Signalized	HCM 7th Edition	WB Left	0.493	17.1	B
7	Fallon Road & Positano Parkway	Signalized	HCM 7th Edition	SB Left	0.707	15.1	B
8	Fallon Road & Central Parkway	Signalized	HCM 7th Edition	SB Left	0.623	26.3	C
9	Fallon Road & Dublin Boulevard	Signalized	HCM 7th Edition	NB Left	0.887	83.4	F
10	Fallon Road & Fallon Gateway	Signalized	HCM 7th Edition	WB Left	0.728	42.4	D
11	Fallon Road & I-580 WB Ramps	Signalized	HCM 7th Edition	NB Thru	1.196	113.4	F
12	El Charro Road & I-580 EB Ramps	Signalized	HCM 7th Edition	EB Left	0.831	8.5	A
13	El Charro Road & Jack London Boulevard	Signalized	HCM 7th Edition	NB Left	0.798	38.6	D
14	Central Parkway & Sunset View Drive	Signalized	HCM 7th Edition	SB Left	0.286	11.8	B
15	Central Parkway & Panorama Drive/Pino Grande Road	All-way stop	HCM 7th Edition	EB Left	0.149	8.2	A
16	Airway Boulevard & N. Canyons Parkway	Signalized	HCM 7th Edition	WB Left	1.146	142.7	F
17	Airway Boulevard & I-580 WB Ramps	Signalized	HCM 7th Edition	WB Left	0.383	9.2	A
	Dublin Boulevard &		HCM 7th				



Version 2024 (SP 0-1)

18	Dublin Boulevard & Commercial Access Driveway	Signalized	HCM 7th Edition	SB Left	0.954	54.9	D
19	Pandora Way & Residential Project Access Driveway (Parcel 7)	All-way stop	HCM 7th Edition	SB Thru	0.055	7.1	A
20	Croak Road & Central Parkway	All-way stop	HCM 7th Edition	EB Left	0.611	14.0	B
21	Croak Road & Project Access (Parcel 8)	Two-way stop	HCM 7th Edition	WB Left	0.019	10.4	B
22	Croak Road & Dublin Boulevard	Signalized	HCM 7th Edition	NB Left	0.848	44.6	D

V/C, Delay, LOS: For two-way stop, these values are taken from the movement with the worst (highest) delay value. For all other control types, they are taken for the whole intersection.

**Intersection Level Of Service Report**  
**Intersection 1: Hacienda Drive & Dublin Boulevard**

Control Type:	Signalized	Delay (sec / veh):	44.5
Analysis Method:	HCM 7th Edition	Level Of Service:	D
Analysis Period:	15 minutes	Volume to Capacity (v/c):	0.679

**Intersection Setup**

Name	Hacienda Drive			Hacienda Drive			Dublin Boulevard			Dublin Boulevard		
Approach	Northbound			Southbound			Eastbound			Westbound		
Lane Configuration	[Diagram]			[Diagram]			[Diagram]			[Diagram]		
Turning Movement	Left	Thru	Right	Left	Thru	Right	Left	Thru	Right	Left	Thru	Right
Lane Width [ft]	12.00	12.00	12.00	12.00	12.00	12.00	12.00	12.00	12.00	12.00	12.00	12.00
No. of Lanes in Entry Pocket	2	0	2	2	0	1	2	0	2	2	0	0
Entry Pocket Length [ft]	250.00	100.00	380.00	300.00	100.00	220.00	300.00	100.00	250.00	275.00	100.00	100.00
No. of Lanes in Exit Pocket	0	0	0	0	0	0	0	0	0	0	0	1
Exit Pocket Length [ft]	0.00	0.00	0.00	0.00	0.00	0.00	0.00	0.00	0.00	0.00	0.00	1000.00
Speed [mph]	35.00			35.00			40.00			40.00		
Grade [%]	0.00			0.00			0.00			0.00		
Curb Present	Yes			Yes			Yes			Yes		
Crosswalk	Yes			Yes			Yes			Yes		





**Volumes**

Name	Hacienda Drive			Hacienda Drive			Dublin Boulevard			Dublin Boulevard		
Base Volume Input [veh/h]	423	1063	388	55	505	59	209	1014	569	250	676	21
Base Volume Adjustment Factor	1.0000	1.0000	1.0000	1.0000	1.0000	1.0000	1.0000	1.0000	1.0000	1.0000	1.0000	1.0000
Heavy Vehicles Percentage [%]	0.00	0.20	0.80	0.00	0.20	5.10	1.90	1.10	1.50	1.30	1.60	0.00
Proportion of CAVs [%]	0.00											
Growth Factor	1.0000	1.0000	1.0000	1.0000	1.0000	1.0000	1.0000	1.0000	1.0000	1.0000	1.0000	1.0000
In-Process Volume [veh/h]	0	0	0	0	0	0	0	0	0	0	0	0
Site-Generated Trips [veh/h]	0	0	0	0	0	0	0	0	0	0	0	0
Diverted Trips [veh/h]	0	0	0	0	0	0	0	0	0	0	0	0
Pass-by Trips [veh/h]	0	0	0	0	0	0	0	0	0	0	0	0
Existing Site Adjustment Volume [veh/h]	0	0	0	0	0	0	0	0	0	0	0	0
Other Volume [veh/h]	0	0	0	0	0	0	0	0	0	0	0	0
Right Turn on Red Volume [veh/h]	0	0	0	0	0	0	0	0	0	0	0	0
Total Hourly Volume [veh/h]	423	1063	388	55	505	59	209	1014	569	250	676	21
Peak Hour Factor	0.9400	0.9400	0.9400	0.9400	0.9400	0.9400	0.9400	0.9400	0.9400	0.9400	0.9400	0.9400
Other Adjustment Factor	1.0000	1.0000	1.0000	1.0000	1.0000	1.0000	1.0000	1.0000	1.0000	1.0000	1.0000	1.0000
Total 15-Minute Volume [veh/h]	113	283	103	15	134	16	56	270	151	66	180	6
Total Analysis Volume [veh/h]	450	1131	413	59	537	63	222	1079	605	266	719	22
Presence of On-Street Parking	No		No	No		No	No		No	No		No
On-Street Parking Maneuver Rate [/h]	0	0	0	0	0	0	0	0	0	0	0	0
Local Bus Stopping Rate [/h]	0	0	0	0	0	0	0	0	0	0	0	0
v_do, Outbound Pedestrian Volume crossing	5			2			4			2		
v_di, Inbound Pedestrian Volume crossing m	4			2			5			2		
v_co, Outbound Pedestrian Volume crossing	6			1			2			7		
v_ci, Inbound Pedestrian Volume crossing mi	7			2			1			6		
v_ab, Corner Pedestrian Volume [ped/h]	0			0			0			0		
Bicycle Volume [bicycles/h]	1			0			4			1		



**Intersection Settings**

Located in CBD	No
Signal Coordination Group	-
Cycle Length [s]	150
Active Pattern	Pattern 1
Coordination Type	Time of Day Pattern Coordinated
Actuation Type	Fully actuated
Offset [s]	113.0
Offset Reference	Lead Green - Beginning of First Green
Permissive Mode	SingleBand
Lost time [s]	12.00

**Phasing & Timing (Basic)**

Control Type	Protecte	Permiss	Permiss	Protecte	Permiss	Permiss	Protecte	Permiss	Permiss	Protecte	Permiss	Permiss
Signal Group	3	8	0	7	4	0	5	2	0	1	6	0
Auxiliary Signal Groups												
Maximum Green [s]	20	50	0	20	50	0	20	60	0	20	60	0
Amber [s]	3.5	4.5	0.0	3.5	4.1	0.0	3.5	4.5	0.0	3.5	4.5	0.0
All red [s]	1.5	1.5	0.0	1.0	1.5	0.0	1.0	1.5	0.0	1.0	1.5	0.0
Walk [s]	0	4	0	0	4	0	0	4	0	0	4	0
Pedestrian Clearance [s]	0	32	0	0	40	0	0	43	0	0	35	0
Delayed Vehicle Green [s]	0.0	0.0	0.0	0.0	0.0	0.0	0.0	0.0	0.0	0.0	0.0	0.0
Rest In Walk		No			No			No			No	
I1, Start-Up Lost Time [s]	2.0	2.0	0.0	2.0	2.0	0.0	2.0	2.0	0.0	2.0	2.0	0.0
I2, Clearance Lost Time [s]	2.0	2.0	0.0	2.0	2.0	0.0	2.0	2.0	0.0	2.0	2.0	0.0
Detector Location [ft]	0.0	0.0	0.0	0.0	0.0	0.0	0.0	0.0	0.0	0.0	0.0	0.0
Detector Length [ft]	20.0	20.0	0.0	20.0	20.0	0.0	20.0	20.0	0.0	20.0	20.0	0.0
I, Upstream Filtering Factor	1.00	1.00	1.00	1.00	1.00	1.00	1.00	1.00	1.00	1.00	1.00	1.00

**Phasing & Timing: Pattern 1**

Split [s]	18	55	0	14	51	0	15	61	0	20	66	0
Lead / Lag	Lead	-	-	Lead	-	-	Lead	-	-	Lead	-	-
Minimum Green [s]	4	10	0	4	10	0	4	10	0	8	10	0
Vehicle Extension [s]	3.0	3.5	0.0	3.0	3.5	0.0	3.0	3.5	0.0	3.0	3.5	0.0
Minimum Recall	No	No		No	No		No	Yes		No	Yes	
Maximum Recall	No	No		No	No		No	No		No	No	
Pedestrian Recall	No	No		No	No		No	No		No	No	

**Exclusive Pedestrian Phase**

Pedestrian Signal Group	0
Pedestrian Walk [s]	0
Pedestrian Clearance [s]	0



**Lane Group Calculations**

Lane Group	L	C	R	L	C	R	L	C	R	L	C	C
C, Cycle Length [s]	150	150	150	150	150	150	150	150	150	150	150	150
L, Total Lost Time per Cycle [s]	4.00	4.00	4.00	4.00	4.00	4.00	4.00	4.00	4.00	4.00	4.00	4.00
l1_p, Permitted Start-Up Lost Time [s]	0.00	0.00	0.00	0.00	0.00	0.00	0.00	0.00	0.00	0.00	0.00	0.00
l2, Clearance Lost Time [s]	2.00	2.00	2.00	2.00	2.00	2.00	2.00	2.00	2.00	2.00	2.00	2.00
g_i, Effective Green Time [s]	14	53	53	5	44	44	11	62	62	14	65	65
g / C, Green / Cycle	0.09	0.35	0.35	0.03	0.29	0.29	0.07	0.41	0.41	0.09	0.43	0.43
(v / s)_i Volume / Saturation Flow Rate	0.09	0.31	0.15	0.02	0.10	0.04	0.06	0.21	0.22	0.08	0.14	0.14
s, saturation flow rate [veh/h]	5271	3612	2774	3514	5167	1545	3461	5131	2767	3478	3572	1845
c, Capacity [veh/h]	493	1276	980	112	1506	450	255	2128	1147	326	1552	802
d1, Uniform Delay [s]	67.44	45.71	36.74	71.59	42.06	39.29	68.83	32.57	32.73	66.79	27.80	27.81
k, delay calibration	0.11	0.13	0.13	0.11	0.13	0.13	0.11	0.50	0.50	0.11	0.50	0.50
l, Upstream Filtering Factor	1.00	1.00	1.00	1.00	1.00	1.00	1.00	1.00	1.00	1.00	1.00	1.00
d2, Incremental Delay [s]	6.96	2.72	0.35	3.83	0.17	0.17	8.84	0.87	1.74	5.02	0.53	1.03
d3, Initial Queue Delay [s]	0.00	0.00	0.00	0.00	0.00	0.00	0.00	0.00	0.00	0.00	0.00	0.00
Rp, platoon ratio	1.00	1.00	1.00	1.00	1.00	1.00	1.00	1.00	1.00	1.00	1.00	1.00
PF, progression factor	1.00	1.00	1.00	1.00	1.00	1.00	1.00	1.00	1.00	1.00	1.00	1.00

**Lane Group Results**

X, volume / capacity	0.91	0.89	0.42	0.53	0.36	0.14	0.87	0.51	0.53	0.82	0.31	0.32
d, Delay for Lane Group [s/veh]	74.40	48.44	37.09	75.42	42.23	39.46	77.67	33.43	34.46	71.81	28.33	28.84
Lane Group LOS	E	D	D	E	D	D	E	C	C	E	C	C
Critical Lane Group	No	Yes	No	Yes	No	No	No	No	Yes	Yes	No	No
50th-Percentile Queue Length [veh/ln]	6.01	20.09	5.80	1.18	5.30	1.76	4.50	9.77	8.39	5.19	5.84	6.16
50th-Percentile Queue Length [ft/ln]	150.14	502.31	145.07	29.44	132.48	43.89	112.46	244.15	209.66	129.74	145.91	154.01
95th-Percentile Queue Length [veh/ln]	10.02	27.44	9.75	2.12	9.07	3.16	7.98	14.89	13.14	8.93	9.80	10.23
95th-Percentile Queue Length [ft/ln]	250.62	686.09	243.83	53.00	226.87	78.99	199.42	372.27	328.39	223.14	244.96	255.77



**Movement, Approach, & Intersection Results**

d_M, Delay for Movement [s/veh]	74.40	48.44	37.09	75.42	42.23	39.46	77.67	33.43	34.46	71.81	28.50	28.84
Movement LOS	E	D	D	E	D	D	E	C	C	E	C	C
d_A, Approach Delay [s/veh]	51.95			44.94			38.91			39.94		
Approach LOS	D			D			D			D		
d_I, Intersection Delay [s/veh]	44.48											
Intersection LOS	D											
Intersection V/C	0.679											

**Emissions**

Vehicle Miles Traveled [mph]	45.67	114.77	41.91	6.87	62.50	7.33	25.37	123.33	69.15	233.90	429.23	222.35
Stops [stops/h]	432.18	963.91	278.38	56.50	381.34	42.11	215.81	702.75	402.32	248.96	279.99	147.77
Fuel consumption [US gal/h]	11.80	22.77	6.81	1.59	9.87	1.10	6.54	18.66	10.67	14.71	20.94	10.90
CO [g/h]	825.04	1591.70	475.89	111.29	689.58	77.03	456.95	1304.47	745.97	1028.27	1463.68	761.94
NOx [g/h]	160.52	309.69	92.59	21.65	134.17	14.99	88.91	253.80	145.14	200.06	284.78	148.25
VOC [g/h]	191.21	368.89	110.29	25.79	159.82	17.85	105.90	302.32	172.89	238.31	339.22	176.59

**Other Modes**

g_Walk,mi, Effective Walk Time [s]	8.0			8.0			8.0			8.0		
M_corner, Corner Circulation Area [ft <sup>2</sup> /ped]	0.00			0.00			0.00			0.00		
M_CW, Crosswalk Circulation Area [ft <sup>2</sup> /ped]	0.00			1164.64			1472.71			57.97		
d_p, Pedestrian Delay [s]	67.25			67.25			67.25			67.25		
I_p,int, Pedestrian LOS Score for Intersectio	3.380			3.041			3.400			3.167		
Crosswalk LOS	C			C			C			C		
s_b, Saturation Flow Rate of the bicycle lane	2000			2000			2000			2000		
c_b, Capacity of the bicycle lane [bicycles/h]	653			605			733			800		
d_b, Bicycle Delay [s]	34.06			36.51			30.18			27.05		
I_b,int, Bicycle LOS Score for Intersection	3.205			1.922			2.608			2.113		
Bicycle LOS	C			A			B			B		

**Sequence**

Ring 1	1	2	3	4	-	-	-	-	-	-	-	-	-	-	-
Ring 2	5	6	7	8	-	-	-	-	-	-	-	-	-	-	-
Ring 3	-	-	-	-	-	-	-	-	-	-	-	-	-	-	-
Ring 4	-	-	-	-	-	-	-	-	-	-	-	-	-	-	-

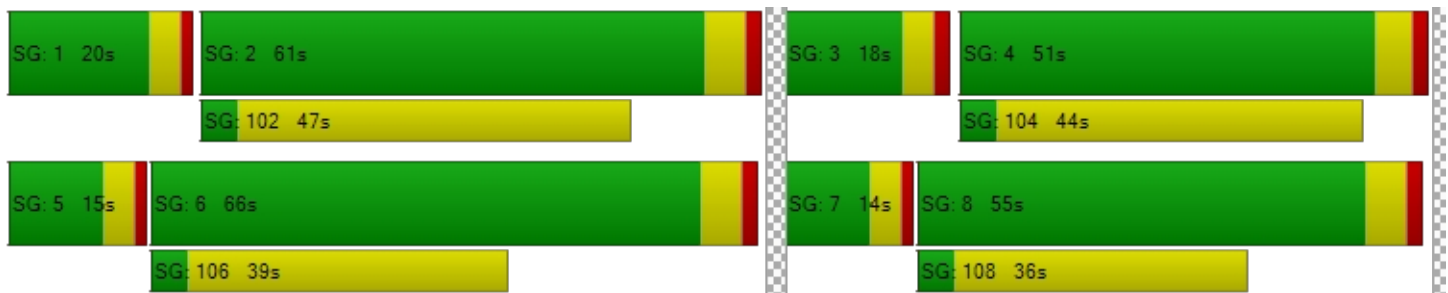

**Intersection Level Of Service Report**  
**Intersection 2: Tassajara Road & Central Parkway**

Control Type:	Signalized	Delay (sec / veh):	45.1
Analysis Method:	HCM 7th Edition	Level Of Service:	D
Analysis Period:	15 minutes	Volume to Capacity (v/c):	0.762

**Intersection Setup**

Name	Tassajara Road			Tassajara Road			Central Parkway			Central Parkway		
Approach	Northbound			Southbound			Eastbound			Westbound		
Lane Configuration	⇐   ⇐			⇐   ⇐			⇐  ⇐			⇐  ⇐		
Turning Movement	Left	Thru	Right	Left	Thru	Right	Left	Thru	Right	Left	Thru	Right
Lane Width [ft]	12.00	12.00	12.00	12.00	12.00	12.00	12.00	12.00	12.00	12.00	12.00	12.00
No. of Lanes in Entry Pocket	1	0	1	1	0	1	1	0	1	2	0	0
Entry Pocket Length [ft]	325.00	100.00	325.00	300.00	100.00	215.00	225.00	100.00	225.00	300.00	100.00	100.00
No. of Lanes in Exit Pocket	0	0	0	0	0	0	0	0	0	0	0	0
Exit Pocket Length [ft]	0.00	0.00	0.00	0.00	0.00	0.00	0.00	0.00	0.00	0.00	0.00	0.00
Speed [mph]	40.00			40.00			35.00			35.00		
Grade [%]	0.00			0.00			0.00			0.00		
Curb Present	Yes			Yes			Yes			Yes		
Crosswalk	Yes			Yes			Yes			Yes		



**Volumes**

Name	Tassajara Road			Tassajara Road			Central Parkway			Central Parkway		
Base Volume Input [veh/h]	69	912	206	26	1025	43	69	443	279	208	112	23
Base Volume Adjustment Factor	1.0000	1.0000	1.0000	1.0000	1.0000	1.0000	1.0000	1.0000	1.0000	1.0000	1.0000	1.0000
Heavy Vehicles Percentage [%]	0.00	0.10	0.00	0.00	0.60	0.00	0.00	0.00	0.00	0.00	0.00	0.00
Proportion of CAVs [%]	0.00											
Growth Factor	1.0000	1.0000	1.0000	1.0000	1.0000	1.0000	1.0000	1.0000	1.0000	1.0000	1.0000	1.0000
In-Process Volume [veh/h]	0	0	0	0	0	0	0	0	0	0	0	0
Site-Generated Trips [veh/h]	0	0	0	0	0	0	0	0	0	0	0	0
Diverted Trips [veh/h]	0	0	0	0	0	0	0	0	0	0	0	0
Pass-by Trips [veh/h]	0	0	0	0	0	0	0	0	0	0	0	0
Existing Site Adjustment Volume [veh/h]	0	0	0	0	0	0	0	0	0	0	0	0
Other Volume [veh/h]	0	0	0	0	0	0	0	0	0	0	0	0
Right Turn on Red Volume [veh/h]	0	0	0	0	0	0	0	0	0	0	0	0
Total Hourly Volume [veh/h]	69	912	206	26	1025	43	69	443	279	208	112	23
Peak Hour Factor	0.8900	0.8900	0.8900	0.8900	0.8900	0.8900	0.8900	0.8900	0.8900	0.8900	0.8900	0.8900
Other Adjustment Factor	1.0000	1.0000	1.0000	1.0000	1.0000	1.0000	1.0000	1.0000	1.0000	1.0000	1.0000	1.0000
Total 15-Minute Volume [veh/h]	19	256	58	7	288	12	19	124	78	58	31	6
Total Analysis Volume [veh/h]	78	1025	231	29	1152	48	78	498	313	234	126	26
Presence of On-Street Parking	No		No	No		No	No		No	No		No
On-Street Parking Maneuver Rate [/h]	0	0	0	0	0	0	0	0	0	0	0	0
Local Bus Stopping Rate [/h]	0	0	0	0	0	0	0	0	0	0	0	0
v_do, Outbound Pedestrian Volume crossing	2			1			2			0		
v_di, Inbound Pedestrian Volume crossing m	2			0			2			1		
v_co, Outbound Pedestrian Volume crossing	0			4			5			0		
v_ci, Inbound Pedestrian Volume crossing mi	0			5			4			0		
v_ab, Corner Pedestrian Volume [ped/h]	0			0			0			0		
Bicycle Volume [bicycles/h]	1			1			0			0		



**Intersection Settings**

Located in CBD	No
Signal Coordination Group	-
Cycle Length [s]	130
Active Pattern	Pattern 1
Coordination Type	Time of Day Pattern Coordinated
Actuation Type	Fully actuated
Offset [s]	124.0
Offset Reference	Lead Green - Beginning of First Green
Permissive Mode	SingleBand
Lost time [s]	12.00

**Phasing & Timing (Basic)**

Control Type	Protecte	Permiss	Permiss	Protecte	Permiss	Permiss	Protecte	Permiss	Permiss	Protecte	Permiss	Permiss
Signal Group	3	8	0	7	4	0	5	2	0	1	6	0
Auxiliary Signal Groups												
Maximum Green [s]	20	40	0	20	40	0	20	20	0	20	20	0
Amber [s]	3.5	4.3	0.0	3.5	4.3	0.0	3.5	4.1	0.0	3.5	4.1	0.0
All red [s]	1.0	1.0	0.0	1.0	1.0	0.0	1.0	1.0	0.0	1.0	1.0	0.0
Walk [s]	0	4	0	0	4	0	0	4	0	0	4	0
Pedestrian Clearance [s]	0	20	0	0	24	0	0	36	0	0	30	0
Delayed Vehicle Green [s]	0.0	0.0	0.0	0.0	0.0	0.0	0.0	0.0	0.0	0.0	0.0	0.0
Rest In Walk		No			No			No			No	
I1, Start-Up Lost Time [s]	2.0	2.0	0.0	2.0	2.0	0.0	2.0	2.0	0.0	2.0	2.0	0.0
I2, Clearance Lost Time [s]	2.5	3.3	0.0	2.5	3.3	0.0	2.5	3.1	0.0	2.5	3.1	0.0
Detector Location [ft]	0.0	0.0	0.0	0.0	0.0	0.0	0.0	0.0	0.0	0.0	0.0	0.0
Detector Length [ft]	20.0	20.0	0.0	20.0	20.0	0.0	20.0	20.0	0.0	20.0	20.0	0.0
I, Upstream Filtering Factor	1.00	1.00	1.00	1.00	1.00	1.00	1.00	1.00	1.00	1.00	1.00	1.00

**Phasing & Timing: Pattern 1**

Split [s]	18	48	0	18	48	0	18	45	0	19	46	0
Lead / Lag	Lead	-	-	Lead	-	-	Lead	-	-	Lead	-	-
Minimum Green [s]	13	12	0	13	12	0	13	13	0	14	13	0
Vehicle Extension [s]	2.5	4.0	0.0	2.5	4.0	0.0	2.5	2.5	0.0	2.5	2.5	0.0
Minimum Recall	No	Yes		No	Yes		No	No		No	No	
Maximum Recall	No	No		No	No		No	No		No	No	
Pedestrian Recall	No	No		No	No		No	No		No	No	

**Exclusive Pedestrian Phase**

Pedestrian Signal Group	0
Pedestrian Walk [s]	0
Pedestrian Clearance [s]	0



**Lane Group Calculations**

Lane Group	L	C	R	L	C	R	L	C	R	L	C
C, Cycle Length [s]	130	130	130	130	130	130	130	130	130	130	130
L, Total Lost Time per Cycle [s]	4.50	5.30	5.30	4.50	5.30	5.30	4.50	5.10	5.10	4.50	5.10
l1_p, Permitted Start-Up Lost Time [s]	0.00	0.00	0.00	0.00	0.00	0.00	0.00	0.00	0.00	0.00	0.00
l2, Clearance Lost Time [s]	2.50	3.30	3.30	2.50	3.30	3.30	2.50	3.10	3.10	2.50	3.10
g_i, Effective Green Time [s]	12	52	52	8	48	48	12	37	37	14	38
g / C, Green / Cycle	0.09	0.40	0.40	0.07	0.37	0.37	0.09	0.28	0.28	0.11	0.29
(v / s)_i Volume / Saturation Flow Rate	0.04	0.28	0.15	0.02	0.32	0.03	0.04	0.26	0.19	0.07	0.08
s, saturation flow rate [veh/h]	1810	3615	1581	1810	3600	1562	1810	1900	1608	3514	1844
c, Capacity [veh/h]	171	1436	628	118	1325	575	171	533	451	379	542
d1, Uniform Delay [s]	55.71	32.96	27.55	57.71	38.15	26.74	55.71	45.59	41.73	55.40	35.29
k, delay calibration	0.08	0.50	0.50	0.08	0.50	0.50	0.08	0.32	0.15	0.08	0.08
l, Upstream Filtering Factor	1.00	1.00	1.00	1.00	1.00	1.00	1.00	1.00	1.00	1.00	1.00
d2, Incremental Delay [s]	1.42	3.06	1.66	0.80	7.95	0.28	1.42	18.77	2.65	1.22	0.21
d3, Initial Queue Delay [s]	0.00	0.00	0.00	0.00	0.00	0.00	0.00	0.00	0.00	0.00	0.00
Rp, platoon ratio	1.00	1.00	1.00	1.00	1.00	1.00	1.00	1.00	1.00	1.00	1.00
PF, progression factor	1.00	1.00	1.00	1.00	1.00	1.00	1.00	1.00	1.00	1.00	1.00

**Lane Group Results**

X, volume / capacity	0.46	0.71	0.37	0.25	0.87	0.08	0.46	0.93	0.69	0.62	0.28
d, Delay for Lane Group [s/veh]	57.13	36.01	29.21	58.50	46.10	27.02	57.13	64.36	44.38	56.62	35.50
Lane Group LOS	E	D	C	E	D	C	E	E	D	E	D
Critical Lane Group	Yes	No	No	No	Yes	No	No	Yes	No	Yes	No
50th-Percentile Queue Length [veh/ln]	2.46	13.80	5.26	0.92	17.97	1.01	2.48	18.20	9.20	3.71	3.73
50th-Percentile Queue Length [ft/ln]	61.53	344.91	131.46	23.06	449.16	25.24	61.99	455.01	230.09	92.80	93.37
95th-Percentile Queue Length [veh/ln]	4.43	19.89	9.02	1.66	24.92	1.82	4.46	25.20	14.18	6.68	6.72
95th-Percentile Queue Length [ft/ln]	110.75	497.20	225.48	41.52	622.95	45.42	111.58	629.92	354.47	167.05	168.07





**Movement, Approach, & Intersection Results**

d_M, Delay for Movement [s/veh]	57.13	36.01	29.21	58.50	46.10	27.02	57.13	64.36	44.38	56.62	35.50	35.50
Movement LOS	E	D	C	E	D	C	E	E	D	E	D	D
d_A, Approach Delay [s/veh]	36.07			45.64			56.69			48.30		
Approach LOS	D			D			E			D		
d_I, Intersection Delay [s/veh]	45.14											
Intersection LOS	D											
Intersection V/C	0.762											

**Emissions**

Vehicle Miles Traveled [mph]	22.49	295.60	66.62	5.52	219.14	9.13	10.26	65.54	41.19	31.73	20.61
Stops [stops/h]	68.17	764.23	145.64	25.55	995.23	27.96	68.68	504.09	254.91	205.63	103.45
Fuel consumption [US gal/h]	2.38	25.61	5.19	0.79	28.43	0.87	1.81	12.81	6.31	5.45	2.66
CO [g/h]	166.51	1789.96	362.79	55.49	1987.39	60.51	126.83	895.49	441.32	381.09	186.04
NOx [g/h]	32.40	348.26	70.58	10.80	386.67	11.77	24.68	174.23	85.86	74.15	36.20
VOC [g/h]	38.59	414.84	84.08	12.86	460.60	14.02	29.39	207.54	102.28	88.32	43.12

**Other Modes**

g_Walk,mi, Effective Walk Time [s]	8.0		8.0		8.0		8.0	
M_corner, Corner Circulation Area [ft <sup>2</sup> /ped]	0.00		0.00		0.00		0.00	
M_CW, Crosswalk Circulation Area [ft <sup>2</sup> /ped]	669.69		5331.48		495.99		0.00	
d_p, Pedestrian Delay [s]	57.24		57.24		57.24		57.24	
I_p,int, Pedestrian LOS Score for Intersectio	3.238		2.983		2.475		2.476	
Crosswalk LOS	C		C		B		B	
s_b, Saturation Flow Rate of the bicycle lane	2000		2000		2000		2000	
c_b, Capacity of the bicycle lane [bicycles/h]	657		657		614		629	
d_b, Bicycle Delay [s]	29.32		29.32		31.21		30.52	
I_b,int, Bicycle LOS Score for Intersection	2.660		2.574		3.026		2.197	
Bicycle LOS	B		B		C		B	

**Sequence**

Ring 1	1	2	3	4	-	-	-	-	-	-	-	-	-	-	-
Ring 2	5	6	7	8	-	-	-	-	-	-	-	-	-	-	-
Ring 3	-	-	-	-	-	-	-	-	-	-	-	-	-	-	-
Ring 4	-	-	-	-	-	-	-	-	-	-	-	-	-	-	-

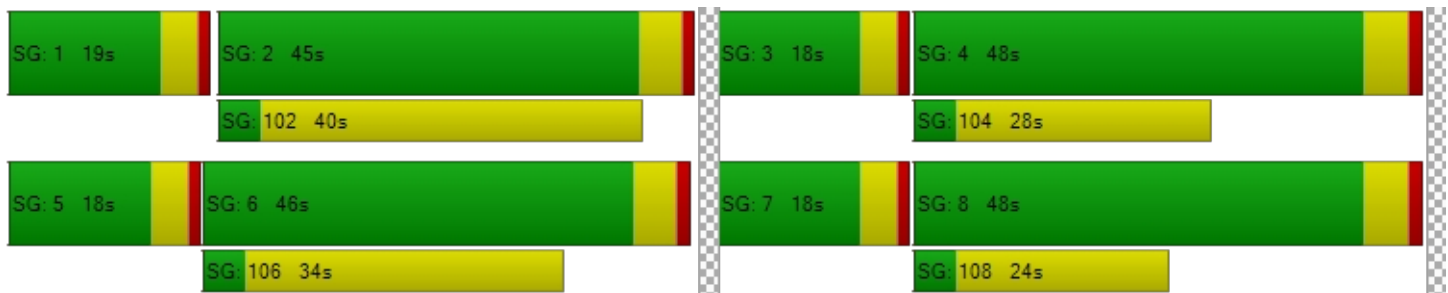

**Intersection Level Of Service Report**  
**Intersection 3: Tassajara Road & Dublin Boulevard**

Control Type:	Signalized	Delay (sec / veh):	133.1
Analysis Method:	HCM 7th Edition	Level Of Service:	F
Analysis Period:	15 minutes	Volume to Capacity (v/c):	1.330

**Intersection Setup**

Name	Tassajara Road			Tassajara Road			Dublin Boulevard			Dublin Boulevard		
Approach	Northbound			Southbound			Eastbound			Westbound		
Lane Configuration	[Diagram]			[Diagram]			[Diagram]			[Diagram]		
Turning Movement	Left	Thru	Right	Left	Thru	Right	Left	Thru	Right	Left	Thru	Right
Lane Width [ft]	12.00	12.00	12.00	12.00	12.00	12.00	12.00	12.00	12.00	12.00	12.00	12.00
No. of Lanes in Entry Pocket	3	0	1	2	0	2	2	0	2	3	0	0
Entry Pocket Length [ft]	380.00	100.00	250.00	295.00	100.00	290.00	265.00	100.00	330.00	395.00	100.00	100.00
No. of Lanes in Exit Pocket	0	0	1	0	0	0	0	0	0	0	0	0
Exit Pocket Length [ft]	0.00	0.00	49.21	0.00	0.00	0.00	0.00	0.00	0.00	0.00	0.00	0.00
Speed [mph]	30.00			40.00			40.00			40.00		
Grade [%]	0.00			0.00			0.00			0.00		
Curb Present	Yes			Yes			Yes			Yes		
Crosswalk	Yes			Yes			Yes			Yes		



**Volumes**

Name	Tassajara Road			Tassajara Road			Dublin Boulevard			Dublin Boulevard		
Base Volume Input [veh/h]	303	781	995	304	1181	142	259	826	469	824	532	44
Base Volume Adjustment Factor	1.0000	1.0000	1.0000	1.0000	1.0000	1.0000	1.0000	1.0000	1.0000	1.0000	1.0000	1.0000
Heavy Vehicles Percentage [%]	0.70	0.00	0.00	1.20	0.40	0.00	0.40	0.80	13.00	0.20	1.30	0.00
Proportion of CAVs [%]	0.00											
Growth Factor	1.0000	1.0000	1.0000	1.0000	1.0000	1.0000	1.0000	1.0000	1.0000	1.0000	1.0000	1.0000
In-Process Volume [veh/h]	0	0	0	0	0	0	0	0	0	0	0	0
Site-Generated Trips [veh/h]	0	0	0	0	0	0	0	0	0	0	0	0
Diverted Trips [veh/h]	0	0	0	0	0	0	0	0	0	0	0	0
Pass-by Trips [veh/h]	0	0	0	0	0	0	0	0	0	0	0	0
Existing Site Adjustment Volume [veh/h]	0	0	0	0	0	0	0	0	0	0	0	0
Other Volume [veh/h]	0	0	0	0	0	0	0	0	0	0	0	0
Right Turn on Red Volume [veh/h]	0	0	0	0	0	0	0	0	0	0	0	0
Total Hourly Volume [veh/h]	303	781	995	304	1181	142	259	826	469	824	532	44
Peak Hour Factor	0.9100	0.9100	0.9100	0.9100	0.9100	0.9100	0.9100	0.9100	0.9100	0.9100	0.9100	0.9100
Other Adjustment Factor	1.0000	1.0000	1.0000	1.0000	1.0000	1.0000	1.0000	1.0000	1.0000	1.0000	1.0000	1.0000
Total 15-Minute Volume [veh/h]	83	215	273	84	324	39	71	227	129	226	146	12
Total Analysis Volume [veh/h]	333	858	1093	334	1298	156	285	908	515	905	585	48
Presence of On-Street Parking	No		No	No		No	No		No	No		No
On-Street Parking Maneuver Rate [/h]	0	0	0	0	0	0	0	0	0	0	0	0
Local Bus Stopping Rate [/h]	0	0	0	0	0	0	0	0	0	0	0	0
v_do, Outbound Pedestrian Volume crossing	0			2			3			0		
v_di, Inbound Pedestrian Volume crossing m	0			3			2			0		
v_co, Outbound Pedestrian Volume crossing	0			4			0			3		
v_ci, Inbound Pedestrian Volume crossing mi	0			3			0			4		
v_ab, Corner Pedestrian Volume [ped/h]	0			0			0			0		
Bicycle Volume [bicycles/h]	1			0			1			0		



**Intersection Settings**

Located in CBD	No
Signal Coordination Group	-
Cycle Length [s]	90
Active Pattern	Free Running (No Pattern)
Coordination Type	<i>Free Running</i>
Actuation Type	<i>Fully actuated</i>
Offset [s]	0.0
Offset Reference	Lead Green - Beginning of First Green
Permissive Mode	SingleBand
Lost time [s]	12.00

**Phasing & Timing (Basic)**

Control Type	Protecte	Permiss	Permiss	Protecte	Permiss	Permiss	Protecte	Permiss	Overlap	Protecte	Permiss	Permiss
Signal Group	3	8	0	7	4	0	5	2	2	1	6	0
Auxiliary Signal Groups									2,3			
Maximum Green [s]	20	35	0	20	35	0	20	35	35	20	35	0
Amber [s]	3.5	4.5	0.0	3.5	4.5	0.0	3.5	4.5	4.5	3.5	4.5	0.0
All red [s]	1.5	1.5	0.0	1.5	1.5	0.0	1.5	1.5	1.5	1.5	1.5	0.0
Walk [s]	0	4	0	0	4	0	0	0	0	0	4	0
Pedestrian Clearance [s]	0	29	0	0	42	0	0	0	0	0	42	0
Delayed Vehicle Green [s]	0.0	0.0	0.0	0.0	0.0	0.0	0.0	0.0	0.0	0.0	0.0	0.0
Rest In Walk		No			No			No			No	
I1, Start-Up Lost Time [s]	2.0	2.0	0.0	2.0	2.0	0.0	2.0	2.0	2.0	2.0	2.0	0.0
I2, Clearance Lost Time [s]	2.0	2.0	0.0	2.0	2.0	0.0	2.0	2.0	2.0	2.0	2.0	0.0
Detector Location [ft]	0.0	0.0	0.0	0.0	0.0	0.0	0.0	0.0	0.0	0.0	0.0	0.0
Detector Length [ft]	20.0	20.0	0.0	20.0	20.0	0.0	20.0	20.0	20.0	20.0	20.0	0.0
I, Upstream Filtering Factor	1.00	1.00	1.00	1.00	1.00	1.00	1.00	1.00	1.00	1.00	1.00	1.00

**Phasing & Timing: Free Running (No Pattern)**

Split [s]	0	0	0	0	0	0	0	0	0	0	0	0
Lead / Lag	Lead	-	-	Lead	-	-	Lead	-	-	Lead	-	-
Minimum Green [s]	16	15	0	15	15	0	16	16	16	16	15	0
Vehicle Extension [s]	2.0	4.0	0.0	2.0	4.0	0.0	2.0	3.0	3.0	2.0	3.0	0.0
Minimum Recall	No	Yes		No	Yes		No	No	No	No	No	
Maximum Recall	No	No		No	No		No	No	No	No	No	
Pedestrian Recall	No	No		No	No		No	No	No	No	No	

**Exclusive Pedestrian Phase**

Pedestrian Signal Group	0
Pedestrian Walk [s]	0
Pedestrian Clearance [s]	0



**Lane Group Calculations**

Lane Group	L	C	R	L	C	R	L	C	R	L	C	C
C, Cycle Length [s]	128	128	128	128	128	128	128	128	128	128	128	128
L, Total Lost Time per Cycle [s]	4.00	4.00	4.00	4.00	4.00	4.00	4.00	4.00	4.00	4.00	4.00	4.00
l1_p, Permitted Start-Up Lost Time [s]	0.00	0.00	0.00	0.00	0.00	0.00	0.00	0.00	0.00	0.00	0.00	0.00
l2, Clearance Lost Time [s]	2.00	2.00	2.00	2.00	2.00	2.00	2.00	2.00	0.00	2.00	2.00	2.00
g_i, Effective Green Time [s]	21	39	39	16	35	35	17	36	61	21	40	40
g / C, Green / Cycle	0.16	0.30	0.30	0.13	0.27	0.27	0.13	0.28	0.47	0.16	0.31	0.31
(v / s)_i Volume / Saturation Flow Rate	0.06	0.24	0.69	0.10	0.19	0.05	0.08	0.25	0.20	0.17	0.17	0.17
s, saturation flow rate [veh/h]	5242	3618	1594	3481	6879	2843	3503	3595	2545	5263	1880	1829
c, Capacity [veh/h]	840	1099	484	437	1851	765	466	1017	1187	859	589	573
d1, Uniform Delay [s]	48.43	40.87	44.53	54.38	42.34	36.33	52.60	44.24	22.90	53.81	36.55	36.63
k, delay calibration	0.04	0.15	0.50	0.04	0.15	0.15	0.04	0.11	0.11	0.04	0.18	0.18
l, Upstream Filtering Factor	1.00	1.00	1.00	1.00	1.00	1.00	1.00	1.00	1.00	1.00	1.00	1.00
d2, Incremental Delay [s]	0.11	1.77	572.21	1.06	0.70	0.19	0.49	3.00	0.25	26.90	1.29	1.39
d3, Initial Queue Delay [s]	0.00	0.00	0.00	0.00	0.00	0.00	0.00	0.00	0.00	0.00	0.00	0.00
Rp, platoon ratio	1.00	1.00	1.00	1.00	1.00	1.00	1.00	1.00	1.00	1.00	1.00	1.00
PF, progression factor	1.00	1.00	1.00	1.00	1.00	1.00	1.00	1.00	1.00	1.00	1.00	1.00

**Lane Group Results**

X, volume / capacity	0.40	0.78	2.26	0.76	0.70	0.20	0.61	0.89	0.43	1.05	0.54	0.55
d, Delay for Lane Group [s/veh]	48.54	42.63	616.74	55.44	43.04	36.52	53.09	47.24	23.15	80.71	37.84	38.02
Lane Group LOS	D	D	F	E	D	D	D	D	C	F	D	D
Critical Lane Group	No	No	Yes	Yes	No	No	No	Yes	No	Yes	No	No
50th-Percentile Queue Length [veh/ln]	3.22	12.61	92.16	5.21	9.19	1.90	4.31	13.94	5.10	11.21	8.35	8.23
50th-Percentile Queue Length [ft/ln]	80.46	315.37	2304.01	130.31	229.67	47.40	107.81	348.41	127.50	280.33	208.65	205.75
95th-Percentile Queue Length [veh/ln]	5.79	18.44	146.53	8.96	14.16	3.41	7.72	20.06	8.80	17.13	13.08	12.93
95th-Percentile Queue Length [ft/ln]	144.83	460.99	3663.23	223.92	353.94	85.33	192.95	501.47	220.09	428.14	327.10	323.37



**Movement, Approach, & Intersection Results**

d_M, Delay for Movement [s/veh]	48.54	42.63	616.74	55.44	43.04	36.52	53.09	47.24	23.15	80.71	37.92	38.02
Movement LOS	D	D	F	E	D	D	D	D	C	F	D	D
d_A, Approach Delay [s/veh]	318.23			44.79			40.95			63.10		
Approach LOS	F			D			D			E		
d_I, Intersection Delay [s/veh]	133.08											
Intersection LOS	F											
Intersection V/C	1.330											

**Emissions**

Vehicle Miles Traveled [mph]	68.31	176.00	224.21	96.32	374.33	44.99	250.61	798.42	452.85	1088.85	384.18	377.42
Stops [stops/h]	270.64	707.20	2583.32	292.23	1030.04	106.30	241.76	781.29	285.91	942.95	233.95	230.69
Fuel consumption [US gal/h]	7.60	18.60	160.65	10.09	34.89	3.81	14.43	45.00	21.46	63.13	18.52	18.21
CO [g/h]	530.97	1299.86	11229.1	705.19	2439.13	266.67	1008.69	3145.70	1499.79	4412.68	1294.42	1273.04
NOx [g/h]	103.31	252.91	2184.79	137.20	474.57	51.88	196.25	612.04	291.81	858.55	251.85	247.69
VOC [g/h]	123.06	301.25	2602.47	163.43	565.29	61.80	233.77	729.05	347.59	1022.68	299.99	295.04

**Other Modes**

g_Walk,mi, Effective Walk Time [s]	-6.0		8.0		8.0		8.0	
M_corner, Corner Circulation Area [ft <sup>2</sup> /ped]	0.00		0.00		0.00		0.00	
M_CW, Crosswalk Circulation Area [ft <sup>2</sup> /ped]	0.00		0.00		0.00		0.00	
d_p, Pedestrian Delay [s]	70.36		56.46		56.46		56.46	
I_p,int, Pedestrian LOS Score for Intersectio	3.482		3.373		3.270		3.374	
Crosswalk LOS	C		C		C		C	
s_b, Saturation Flow Rate of the bicycle lane	2000		2000		2000		2000	
c_b, Capacity of the bicycle lane [bicycles/h]	545		545		545		545	
d_b, Bicycle Delay [s]	34.00		33.98		34.00		33.98	
I_b,int, Bicycle LOS Score for Intersection	3.444		2.297		2.969		2.828	
Bicycle LOS	C		B		C		C	

**Sequence**

Ring 1	1	2	3	4	-	-	-	-	-	-	-	-	-	-	-
Ring 2	5	6	7	8	-	-	-	-	-	-	-	-	-	-	-
Ring 3	-	-	-	-	-	-	-	-	-	-	-	-	-	-	-
Ring 4	-	-	-	-	-	-	-	-	-	-	-	-	-	-	-



**Intersection Level Of Service Report**  
**Intersection 4: Tassajara Road & I-580 WB Ramps**

Control Type:	Signalized	Delay (sec / veh):	16.7
Analysis Method:	HCM 7th Edition	Level Of Service:	B
Analysis Period:	15 minutes	Volume to Capacity (v/c):	0.822

**Intersection Setup**

Name	Tassajara Road		Tassajara Road		I-580 WB Ramps	
Approach	Northbound		Southbound		Westbound	
Lane Configuration	↑↑		↑↑↑		↔↔↔↔	
Turning Movement	Thru	Right	Left	Thru	Left	Right
Lane Width [ft]	12.00	12.00	12.00	12.00	12.00	12.00
No. of Lanes in Entry Pocket	0	0	0	0	1	1
Entry Pocket Length [ft]	100.00	100.00	100.00	100.00	100.00	100.00
No. of Lanes in Exit Pocket	0	1	0	0	0	0
Exit Pocket Length [ft]	0.00	49.21	0.00	0.00	0.00	0.00
Speed [mph]	30.00		30.00		30.00	
Grade [%]	0.00		0.00		0.00	
Curb Present	No		No		No	
Crosswalk	Yes		Yes		Yes	



**Volumes**

Name	Tassajara Road		Tassajara Road		I-580 WB Ramps	
Base Volume Input [veh/h]	1972	0	0	1887	596	306
Base Volume Adjustment Factor	1.0000	1.0000	1.0000	1.0000	1.0000	1.0000
Heavy Vehicles Percentage [%]	0.40	2.00	2.00	0.80	0.40	1.70
Proportion of CAVs [%]	0.00					
Growth Factor	1.0000	1.0000	1.0000	1.0000	1.0000	1.0000
In-Process Volume [veh/h]	0	0	0	0	0	0
Site-Generated Trips [veh/h]	0	0	0	0	0	0
Diverted Trips [veh/h]	0	0	0	0	0	0
Pass-by Trips [veh/h]	0	0	0	0	0	0
Existing Site Adjustment Volume [veh/h]	0	0	0	0	0	0
Other Volume [veh/h]	0	0	0	0	0	0
Right Turn on Red Volume [veh/h]	0	0	0	0	0	0
Total Hourly Volume [veh/h]	1972	0	0	1887	596	306
Peak Hour Factor	0.9600	1.0000	1.0000	0.9600	0.9600	0.9600
Other Adjustment Factor	1.0000	1.0000	1.0000	1.0000	1.0000	1.0000
Total 15-Minute Volume [veh/h]	514	0	0	491	155	80
Total Analysis Volume [veh/h]	2054	0	0	1966	621	319
Presence of On-Street Parking	No	No	No	No	No	No
On-Street Parking Maneuver Rate [/h]	0	0	0	0	0	0
Local Bus Stopping Rate [/h]	0	0	0	0	0	0
v_do, Outbound Pedestrian Volume crossing	0		0		0	
v_di, Inbound Pedestrian Volume crossing m	0		0		0	
v_co, Outbound Pedestrian Volume crossing	0		0		0	
v_ci, Inbound Pedestrian Volume crossing mi	0		0		0	
v_ab, Corner Pedestrian Volume [ped/h]	0		0		0	
Bicycle Volume [bicycles/h]	1		0		0	





**Intersection Settings**

Located in CBD	No
Signal Coordination Group	-
Cycle Length [s]	60
Active Pattern	Pattern 1
Coordination Type	Time of Day Pattern Coordinated
Actuation Type	Fully actuated
Offset [s]	29.0
Offset Reference	Beginning of First Yellow
Permissive Mode	SingleBand
Lost time [s]	6.00

**Phasing & Timing (Basic)**

Control Type	Permissive	Permissive	Permissive	Permissive	Permissive	Permissive
Signal Group	6	0	0	2	4	0
Auxiliary Signal Groups						
Maximum Green [s]	40	0	0	40	20	0
Amber [s]	4.9	0.0	0.0	4.9	4.4	0.0
All red [s]	1.0	0.0	0.0	1.0	1.0	0.0
Walk [s]	5	0	0	0	0	0
Pedestrian Clearance [s]	16	0	0	0	0	0
Delayed Vehicle Green [s]	0.0	0.0	0.0	0.0	0.0	0.0
Rest In Walk	No			No	No	
I1, Start-Up Lost Time [s]	2.0	0.0	0.0	2.0	2.0	0.0
I2, Clearance Lost Time [s]	3.9	0.0	0.0	3.9	3.4	0.0
Detector Location [ft]	0.0	0.0	0.0	0.0	0.0	0.0
Detector Length [ft]	20.0	0.0	0.0	20.0	20.0	0.0
I, Upstream Filtering Factor	1.00	1.00	1.00	1.00	1.00	1.00

**Phasing & Timing: Pattern 1**

Split [s]	36	0	0	36	24	0
Lead / Lag	-	-	-	-	Lead	-
Minimum Green [s]	7	0	0	7	4	0
Vehicle Extension [s]	3.0	0.0	0.0	3.0	2.0	0.0
Minimum Recall	No			No	No	
Maximum Recall	Yes			Yes	No	
Pedestrian Recall	Yes			No	No	

**Exclusive Pedestrian Phase**

Pedestrian Signal Group	0
Pedestrian Walk [s]	0
Pedestrian Clearance [s]	0



**Lane Group Calculations**

Lane Group	C	C	L	R
C, Cycle Length [s]	66	66	66	66
L, Total Lost Time per Cycle [s]	5.90	5.90	5.40	5.40
l1_p, Permitted Start-Up Lost Time [s]	0.00	0.00	0.00	0.00
l2, Clearance Lost Time [s]	3.90	3.90	3.40	3.40
g_i, Effective Green Time [s]	40	40	14	14
g / C, Green / Cycle	0.61	0.61	0.22	0.22
(v / s)_i Volume / Saturation Flow Rate	0.57	0.38	0.18	0.11
s, saturation flow rate [veh/h]	3606	5143	3503	2820
c, Capacity [veh/h]	2198	3134	765	616
d1, Uniform Delay [s]	11.63	8.11	24.37	22.60
k, delay calibration	0.50	0.50	0.04	0.04
l, Upstream Filtering Factor	1.00	1.00	1.00	1.00
d2, Incremental Delay [s]	8.97	0.96	0.81	0.25
d3, Initial Queue Delay [s]	0.00	0.00	0.00	0.00
Rp, platoon ratio	1.00	1.00	1.00	1.00
PF, progression factor	1.00	1.00	1.00	1.00

**Lane Group Results**

X, volume / capacity	0.93	0.63	0.81	0.52
d, Delay for Lane Group [s/veh]	20.61	9.07	25.17	22.86
Lane Group LOS	C	A	C	C
Critical Lane Group	Yes	No	Yes	No
50th-Percentile Queue Length [veh/ln]	12.81	4.76	4.38	2.07
50th-Percentile Queue Length [ft/ln]	320.25	118.91	109.38	51.64
95th-Percentile Queue Length [veh/ln]	18.68	8.33	7.81	3.72
95th-Percentile Queue Length [ft/ln]	466.99	208.33	195.14	92.95

**Movement, Approach, & Intersection Results**

d_M, Delay for Movement [s/veh]	20.61	0.00	0.00	9.07	25.17	22.86
Movement LOS	C			A	C	C
d_A, Approach Delay [s/veh]	20.61		9.07		24.39	
Approach LOS	C		A		C	
d_I, Intersection Delay [s/veh]	16.75					
Intersection LOS	B					
Intersection V/C	0.822					

**Emissions**

Vehicle Miles Traveled [mph]	345.87	403.29	50.22	25.80
Stops [stops/h]	1406.44	783.35	480.36	226.79
Fuel consumption [US gal/h]	30.62	24.56	7.90	3.80
CO [g/h]	2140.53	1716.58	552.39	265.53
NOx [g/h]	416.47	333.98	107.48	51.66
VOC [g/h]	496.09	397.83	128.02	61.54

**Other Modes**

g_Walk,mi, Effective Walk Time [s]	18.6	18.6	9.0
M_corner, Corner Circulation Area [ft <sup>2</sup> /ped]	0.00	0.00	0.00
M_CW, Crosswalk Circulation Area [ft <sup>2</sup> /ped]	0.00	0.00	0.00
d_p, Pedestrian Delay [s]	16.83	16.83	24.41
I_p,int, Pedestrian LOS Score for Intersectio	3.175	3.116	2.469
Crosswalk LOS	C	C	B
s_b, Saturation Flow Rate of the bicycle lane	2000	2000	2000
c_b, Capacity of the bicycle lane [bicycles/h]	918	918	567
d_b, Bicycle Delay [s]	9.60	9.60	16.83
I_b,int, Bicycle LOS Score for Intersection	3.254	2.641	1.560
Bicycle LOS	C	B	A

**Sequence**

Ring 1	-	2	-	4	-	-	-	-	-	-	-	-	-	-	-	-
Ring 2	-	6	-	-	-	-	-	-	-	-	-	-	-	-	-	-
Ring 3	-	-	-	-	-	-	-	-	-	-	-	-	-	-	-	-
Ring 4	-	-	-	-	-	-	-	-	-	-	-	-	-	-	-	-



**Intersection Level Of Service Report**  
**Intersection 5: Santa Rita Rd & I-580 EB Ramps/Pimlico Dr**

Control Type:	Signalized	Delay (sec / veh):	45.6
Analysis Method:	HCM 7th Edition	Level Of Service:	D
Analysis Period:	15 minutes	Volume to Capacity (v/c):	0.968

**Intersection Setup**

Name	Santa Rita Road			Tassajara Road			I-580 EB Ramps			Pimlico Drive		
Approach	Northbound			Southbound			Eastbound			Westbound		
Lane Configuration	↑			↵			↵↑			↵↵↵↑		
Turning Movement	Left	Thru	Right	Left	Thru	Right	Left	Thru	Right	Left	Thru	Right
Lane Width [ft]	12.00	12.00	12.00	12.00	12.00	12.00	12.00	12.00	12.00	12.00	12.00	12.00
No. of Lanes in Entry Pocket	0	0	1	1	0	0	1	0	0	2	0	1
Entry Pocket Length [ft]	100.00	100.00	250.00	425.00	100.00	100.00	625.00	100.00	100.00	200.00	100.00	250.00
No. of Lanes in Exit Pocket	0	0	0	0	0	2	0	0	0	0	0	0
Exit Pocket Length [ft]	0.00	0.00	0.00	0.00	0.00	49.21	0.00	0.00	0.00	0.00	0.00	0.00
Speed [mph]	30.00			30.00			30.00			30.00		
Grade [%]	0.00			0.00			0.00			0.00		
Curb Present	No			No			No			No		
Crosswalk	Yes			No			Yes			Yes		



**Volumes**

Name	Santa Rita Road			Tassajara Road			I-580 EB Ramps			Pimlico Drive		
Base Volume Input [veh/h]	0	2021	85	296	1389	0	733	203	0	112	0	431
Base Volume Adjustment Factor	1.0000	1.0000	1.0000	1.0000	1.0000	1.0000	1.0000	1.0000	1.0000	1.0000	1.0000	1.0000
Heavy Vehicles Percentage [%]	2.00	0.30	1.20	0.40	0.40	2.00	1.20	0.50	2.00	0.00	2.00	0.00
Proportion of CAVs [%]	0.00											
Growth Factor	1.0000	1.0000	1.0000	1.0000	1.0000	1.0000	1.0000	1.0000	1.0000	1.0000	1.0000	1.0000
In-Process Volume [veh/h]	0	0	0	0	0	0	0	0	0	0	0	0
Site-Generated Trips [veh/h]	0	0	0	0	0	0	0	0	0	0	0	0
Diverted Trips [veh/h]	0	0	0	0	0	0	0	0	0	0	0	0
Pass-by Trips [veh/h]	0	0	0	0	0	0	0	0	0	0	0	0
Existing Site Adjustment Volume [veh/h]	0	0	0	0	0	0	0	0	0	0	0	0
Other Volume [veh/h]	0	0	0	0	0	0	0	0	0	0	0	0
Right Turn on Red Volume [veh/h]	0	0	0	0	0	0	0	0	0	0	0	0
Total Hourly Volume [veh/h]	0	2021	85	296	1389	0	733	203	0	112	0	431
Peak Hour Factor	1.0000	0.9600	0.9600	0.9600	0.9600	1.0000	0.9600	0.9600	1.0000	0.9600	1.0000	0.9600
Other Adjustment Factor	1.0000	1.0000	1.0000	1.0000	1.0000	1.0000	1.0000	1.0000	1.0000	1.0000	1.0000	1.0000
Total 15-Minute Volume [veh/h]	0	526	22	77	362	0	191	53	0	29	0	112
Total Analysis Volume [veh/h]	0	2105	89	308	1447	0	764	211	0	117	0	449
Presence of On-Street Parking	No		No	No		No	No		No	No		No
On-Street Parking Maneuver Rate [/h]	0	0	0	0	0	0	0	0	0	0	0	0
Local Bus Stopping Rate [/h]	0	0	0	0	0	0	0	0	0	0	0	0
v_do, Outbound Pedestrian Volume crossing	1			0			0			0		
v_di, Inbound Pedestrian Volume crossing m	0			0			1			0		
v_co, Outbound Pedestrian Volume crossing	0			2			3			1		
v_ci, Inbound Pedestrian Volume crossing mi	1			3			2			0		
v_ab, Corner Pedestrian Volume [ped/h]	0			0			0			0		
Bicycle Volume [bicycles/h]	1			0			0			0		



**Intersection Settings**

Located in CBD	No
Signal Coordination Group	-
Cycle Length [s]	120
Active Pattern	Pattern 1
Coordination Type	Time of Day Pattern Coordinated
Actuation Type	Fully actuated
Offset [s]	13.0
Offset Reference	Lead Green - Beginning of First Green
Permissive Mode	SingleBand
Lost time [s]	12.00

**Phasing & Timing (Basic)**

Control Type	Permiss	Permiss	Permiss	Protecte	Permiss	Permiss	Protecte	Permiss	Permiss	Permiss	Permiss	Overlap
Signal Group	0	6	0	5	2	0	3	8	0	7	0	4
Auxiliary Signal Groups												4,5
Maximum Green [s]	0	30	0	20	30	0	27	20	0	20	0	20
Amber [s]	0.0	4.4	0.0	3.0	4.4	0.0	4.4	4.4	0.0	3.5	0.0	3.5
All red [s]	0.0	1.0	0.0	1.0	1.0	0.0	1.0	1.0	0.0	1.0	0.0	1.0
Walk [s]	0	5	0	0	5	0	0	5	0	0	0	0
Pedestrian Clearance [s]	0	25	0	0	8	0	0	25	0	0	0	0
Delayed Vehicle Green [s]	0.0	0.0	0.0	0.0	0.0	0.0	0.0	0.0	0.0	0.0	0.0	0.0
Rest In Walk		No			No			No		No		
I1, Start-Up Lost Time [s]	0.0	2.0	0.0	2.0	2.0	0.0	2.0	2.0	0.0	2.0	0.0	2.0
I2, Clearance Lost Time [s]	0.0	3.4	0.0	2.0	3.4	0.0	3.4	3.4	0.0	2.5	0.0	2.5
Detector Location [ft]	0.0	0.0	0.0	0.0	0.0	0.0	0.0	0.0	0.0	0.0	0.0	0.0
Detector Length [ft]	0.0	0.0	0.0	0.0	0.0	0.0	0.0	0.0	0.0	0.0	0.0	0.0
I, Upstream Filtering Factor	1.00	1.00	1.00	1.00	1.00	1.00	1.00	1.00	1.00	1.00	1.00	1.00

**Phasing & Timing: Pattern 1**

Split [s]	0	40	0	28	68	0	32	36	0	16	0	20
Lead / Lag	-	-	-	Lead	-	-	Lead	-	-	Lead	-	-
Minimum Green [s]	0	7	0	5	7	0	5	5	0	5	0	5
Vehicle Extension [s]	0.0	3.0	0.0	3.0	3.0	0.0	3.0	2.0	0.0	3.0	0.0	2.0
Minimum Recall		No		No	No		No	No		No		No
Maximum Recall		Yes		No	Yes		No	No		No		No
Pedestrian Recall		No		No	Yes		No	No		No		No

**Exclusive Pedestrian Phase**

Pedestrian Signal Group	0
Pedestrian Walk [s]	0
Pedestrian Clearance [s]	0



**Lane Group Calculations**

Lane Group	C	C	L	C	L	C	L	R
C, Cycle Length [s]	120	120	120	120	120	120	120	120
L, Total Lost Time per Cycle [s]	5.40	5.40	4.00	5.40	5.40	5.40	4.50	4.00
l1_p, Permitted Start-Up Lost Time [s]	0.00	0.00	0.00	0.00	0.00	0.00	0.00	0.00
l2, Clearance Lost Time [s]	3.40	3.40	2.00	3.40	3.40	3.40	2.50	0.00
g_i, Effective Green Time [s]	46	46	20	70	27	29	6	33
g / C, Green / Cycle	0.38	0.38	0.17	0.58	0.22	0.24	0.05	0.27
(v / s)_i Volume / Saturation Flow Rate	0.38	0.30	0.17	0.40	0.22	0.11	0.03	0.16
s, saturation flow rate [veh/h]	4379	1835	1804	3606	3481	1892	3514	2859
c, Capacity [veh/h]	1676	702	301	2103	772	452	178	777
d1, Uniform Delay [s]	36.56	32.55	49.89	17.39	46.46	39.08	55.84	37.67
k, delay calibration	0.50	0.50	0.44	0.50	0.11	0.11	0.11	0.04
l, Upstream Filtering Factor	1.00	1.00	1.00	1.00	1.00	1.00	1.00	1.00
d2, Incremental Delay [s]	18.10	8.42	54.81	1.86	12.75	0.73	4.10	0.25
d3, Initial Queue Delay [s]	0.00	0.00	0.00	0.00	0.00	0.00	0.00	0.00
Rp, platoon ratio	1.00	1.00	1.00	1.00	1.00	1.00	1.00	1.00
PF, progression factor	1.00	1.00	1.00	1.00	1.00	1.00	1.00	1.00

**Lane Group Results**

X, volume / capacity	0.98	0.78	1.02	0.69	0.99	0.47	0.66	0.58
d, Delay for Lane Group [s/veh]	54.66	40.97	104.69	19.25	59.21	39.81	59.94	37.92
Lane Group LOS	D	D	F	B	E	D	E	D
Critical Lane Group	Yes	No	Yes	No	Yes	No	No	Yes
50th-Percentile Queue Length [veh/ln]	18.33	15.46	13.57	13.83	12.64	5.43	1.84	5.72
50th-Percentile Queue Length [ft/ln]	458.22	386.53	339.37	345.77	316.01	135.67	46.01	142.96
95th-Percentile Queue Length [veh/ln]	25.35	21.91	19.84	19.93	18.47	9.25	3.31	9.64
95th-Percentile Queue Length [ft/ln]	633.75	547.74	496.04	498.25	461.77	231.18	82.82	241.01

**Movement, Approach, & Intersection Results**

d_M, Delay for Movement [s/veh]	0.00	51.67	40.97	104.69	19.25	0.00	59.21	39.81	0.00	59.94	0.00	37.92
Movement LOS		D	D	F	B		E	D		E		D
d_A, Approach Delay [s/veh]	51.24			34.25			55.01			42.47		
Approach LOS	D			C			E			D		
d_I, Intersection Delay [s/veh]	45.57											
Intersection LOS	D											
Intersection V/C	0.968											

**Emissions**

Vehicle Miles Traveled [mph]	162.29	54.10	51.86	243.66	106.01	29.28	9.99	38.32
Stops [stops/h]	1651.14	464.27	407.63	830.63	759.12	162.96	110.54	343.43
Fuel consumption [US gal/h]	34.11	9.37	10.95	20.29	17.76	3.81	2.45	6.94
CO [g/h]	2383.98	654.62	765.27	1418.15	1241.59	266.66	171.17	485.10
NOx [g/h]	463.84	127.36	148.89	275.92	241.57	51.88	33.30	94.38
VOC [g/h]	552.51	151.71	177.36	328.67	287.75	61.80	39.67	112.43

**Other Modes**

g_Walk,mi, Effective Walk Time [s]	9.0	0.0	9.0	9.0
M_corner, Corner Circulation Area [ft <sup>2</sup> /ped]	0.00	0.00	0.00	0.00
M_CW, Crosswalk Circulation Area [ft <sup>2</sup> /ped]	6546.14	0.00	0.00	0.00
d_p, Pedestrian Delay [s]	51.28	0.00	51.28	51.28
I_p,int, Pedestrian LOS Score for Intersectio	3.079	0.000	2.384	2.544
Crosswalk LOS	C	F	B	B
s_b, Saturation Flow Rate of the bicycle lane	2000	2000	2000	2000
c_b, Capacity of the bicycle lane [bicycles/h]	577	1044	510	192
d_b, Bicycle Delay [s]	30.35	13.69	33.25	49.00
I_b,int, Bicycle LOS Score for Intersection	2.465	3.007	3.168	1.560
Bicycle LOS	B	C	C	A

**Sequence**

Ring 1	-	2	3	4	-	-	-	-	-	-	-	-	-	-	-
Ring 2	5	6	7	8	-	-	-	-	-	-	-	-	-	-	-
Ring 3	-	-	-	-	-	-	-	-	-	-	-	-	-	-	-
Ring 4	-	-	-	-	-	-	-	-	-	-	-	-	-	-	-

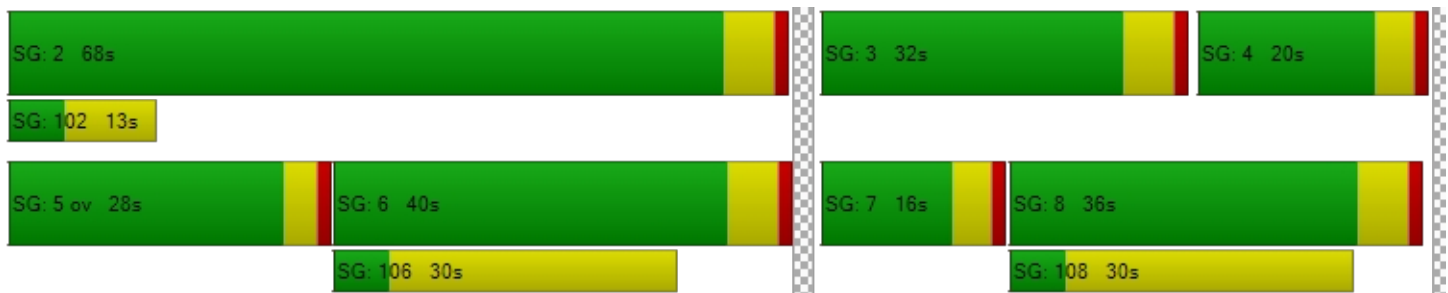



**Intersection Level Of Service Report**  
**Intersection 6: Tassajara Road & Fallon Road**

Control Type:	Signalized	Delay (sec / veh):	17.1
Analysis Method:	HCM 7th Edition	Level Of Service:	B
Analysis Period:	15 minutes	Volume to Capacity (v/c):	0.493

**Intersection Setup**

Name	Fallon Road			Fallon Road			Tassajara Road			Syrah Drive		
Approach	Northbound			Southbound			Eastbound			Westbound		
Lane Configuration												
Turning Movement	Left	Thru	Right	Left	Thru	Right	Left	Thru	Right	Left	Thru	Right
Lane Width [ft]	12.00	12.00	12.00	12.00	12.00	12.00	12.00	12.00	12.00	12.00	12.00	12.00
No. of Lanes in Entry Pocket	1	0	1	1	0	2	1	0	1	1	0	1
Entry Pocket Length [ft]	175.00	100.00	175.00	175.00	100.00	225.00	475.00	100.00	175.00	100.00	100.00	100.00
No. of Lanes in Exit Pocket	0	0	0	0	0	0	0	0	0	0	0	0
Exit Pocket Length [ft]	0.00	0.00	0.00	0.00	0.00	0.00	0.00	0.00	0.00	0.00	0.00	0.00
Speed [mph]	30.00			30.00			30.00			30.00		
Grade [%]	0.00			0.00			0.00			0.00		
Curb Present	No			No			No			No		
Crosswalk	Yes			Yes			Yes			Yes		



**Volumes**

Name	Fallon Road			Fallon Road			Tassajara Road			Syrah Drive		
Base Volume Input [veh/h]	60	369	22	8	482	402	581	30	74	5	17	7
Base Volume Adjustment Factor	1.0000	1.0000	1.0000	1.0000	1.0000	1.0000	1.0000	1.0000	1.0000	1.0000	1.0000	1.0000
Heavy Vehicles Percentage [%]	0.00	0.00	4.80	0.00	2.50	0.30	0.20	0.00	0.00	0.00	0.00	20.00
Proportion of CAVs [%]	0.00											
Growth Factor	1.0000	1.0000	1.0000	1.0000	1.0000	1.0000	1.0000	1.0000	1.0000	1.0000	1.0000	1.0000
In-Process Volume [veh/h]	0	0	0	0	0	0	0	0	0	0	0	0
Site-Generated Trips [veh/h]	0	0	0	0	0	0	0	0	0	0	0	0
Diverted Trips [veh/h]	0	0	0	0	0	0	0	0	0	0	0	0
Pass-by Trips [veh/h]	0	0	0	0	0	0	0	0	0	0	0	0
Existing Site Adjustment Volume [veh/h]	0	0	0	0	0	0	0	0	0	0	0	0
Other Volume [veh/h]	0	0	0	0	0	0	0	0	0	0	0	0
Right Turn on Red Volume [veh/h]	0	0	0	0	0	0	0	0	0	0	0	0
Total Hourly Volume [veh/h]	60	369	22	8	482	402	581	30	74	5	17	7
Peak Hour Factor	0.9200	0.9200	0.9200	0.9200	0.9200	0.9200	0.9200	0.9200	0.9200	0.9200	0.9200	0.9200
Other Adjustment Factor	1.0000	1.0000	1.0000	1.0000	1.0000	1.0000	1.0000	1.0000	1.0000	1.0000	1.0000	1.0000
Total 15-Minute Volume [veh/h]	16	100	6	2	131	109	158	8	20	1	5	2
Total Analysis Volume [veh/h]	65	401	24	9	524	437	632	33	80	5	18	8
Presence of On-Street Parking	No		No	No		No	No		No	No		No
On-Street Parking Maneuver Rate [/h]	0	0	0	0	0	0	0	0	0	0	0	0
Local Bus Stopping Rate [/h]	0	0	0	0	0	0	0	0	0	0	0	0
v_do, Outbound Pedestrian Volume crossing	0			0			0			0		
v_di, Inbound Pedestrian Volume crossing m	0			0			0			0		
v_co, Outbound Pedestrian Volume crossing	0			0			0			0		
v_ci, Inbound Pedestrian Volume crossing mi	0			0			0			0		
v_ab, Corner Pedestrian Volume [ped/h]	0			0			0			0		
Bicycle Volume [bicycles/h]	0			0			0			0		



**Intersection Settings**

Located in CBD	No
Signal Coordination Group	-
Cycle Length [s]	90
Active Pattern	Free Running (No Pattern)
Coordination Type	<i>Free Running</i>
Actuation Type	<i>Fully actuated</i>
Offset [s]	0.0
Offset Reference	Lead Green - Beginning of First Green
Permissive Mode	SingleBand
Lost time [s]	12.00

**Phasing & Timing (Basic)**

Control Type	Protecte	Permiss	Permiss	Protecte	Permiss	Permiss	Protecte	Permiss	Permiss	Protecte	Permiss	Permiss
Signal Group	3	8	0	7	4	0	5	2	0	1	6	0
Auxiliary Signal Groups												
Maximum Green [s]	25	50	0	25	50	0	35	30	0	20	30	0
Amber [s]	3.5	4.8	0.0	3.5	4.8	0.0	3.5	5.0	0.0	3.0	3.6	0.0
All red [s]	1.0	1.0	0.0	1.0	1.0	0.0	1.0	1.0	0.0	1.0	1.0	0.0
Walk [s]	0	4	0	0	0	0	0	4	0	0	3	0
Pedestrian Clearance [s]	0	25	0	0	0	0	0	28	0	0	36	0
Delayed Vehicle Green [s]	0.0	0.0	0.0	0.0	0.0	0.0	0.0	0.0	0.0	0.0	0.0	0.0
Rest In Walk		No			No			No			No	
I1, Start-Up Lost Time [s]	2.0	2.0	0.0	2.0	2.0	0.0	2.0	2.0	0.0	2.0	2.0	0.0
I2, Clearance Lost Time [s]	2.0	2.0	0.0	2.0	2.0	0.0	2.0	2.0	0.0	2.0	2.0	0.0
Detector Location [ft]	0.0	0.0	0.0	0.0	0.0	0.0	0.0	0.0	0.0	0.0	0.0	0.0
Detector Length [ft]	0.0	0.0	0.0	0.0	0.0	0.0	0.0	0.0	0.0	0.0	0.0	0.0
I, Upstream Filtering Factor	1.00	1.00	1.00	1.00	1.00	1.00	1.00	1.00	1.00	1.00	1.00	1.00

**Phasing & Timing: Free Running (No Pattern)**

Split [s]	0	0	0	0	0	0	0	0	0	0	0	0
Lead / Lag	Lead	-	-	Lead	-	-	Lead	-	-	Lead	-	-
Minimum Green [s]	9	10	0	9	10	0	11	8	0	12	9	0
Vehicle Extension [s]	3.0	3.0	0.0	3.0	3.0	0.0	3.0	3.0	0.0	3.0	3.0	0.0
Minimum Recall	No	No		No	No		Yes	No		No	No	
Maximum Recall	No	No		No	No		No	No		No	No	
Pedestrian Recall	No	No		No	No		No	No		No	No	

**Exclusive Pedestrian Phase**

Pedestrian Signal Group	0
Pedestrian Walk [s]	0
Pedestrian Clearance [s]	0



**Lane Group Calculations**

Lane Group	L	C	R	L	C	R	L	C	R	L	C	R
C, Cycle Length [s]	52	52	52	52	52	52	52	52	52	52	52	52
L, Total Lost Time per Cycle [s]	4.00	4.00	4.00	4.00	4.00	4.00	4.00	4.00	4.00	4.00	4.00	4.00
l1_p, Permitted Start-Up Lost Time [s]	0.00	0.00	0.00	0.00	0.00	0.00	0.00	0.00	0.00	0.00	0.00	0.00
l2, Clearance Lost Time [s]	2.00	2.00	2.00	2.00	2.00	2.00	2.00	2.00	2.00	2.00	2.00	2.00
g_i, Effective Green Time [s]	6	18	18	2	13	13	13	16	16	1	3	3
g / C, Green / Cycle	0.12	0.34	0.34	0.03	0.26	0.26	0.25	0.30	0.30	0.02	0.07	0.07
(v / s)_i Volume / Saturation Flow Rate	0.04	0.11	0.02	0.00	0.15	0.15	0.18	0.02	0.05	0.00	0.01	0.01
s, saturation flow rate [veh/h]	1810	3618	1554	1810	3546	2852	3509	1900	1615	1810	1900	1360
c, Capacity [veh/h]	210	1242	533	56	916	736	885	575	488	30	127	91
d1, Uniform Delay [s]	21.13	12.65	11.43	24.61	16.84	16.95	17.79	12.92	13.36	25.31	22.94	22.86
k, delay calibration	0.11	0.11	0.11	0.11	0.11	0.11	0.11	0.11	0.11	0.11	0.11	0.11
l, Upstream Filtering Factor	1.00	1.00	1.00	1.00	1.00	1.00	1.00	1.00	1.00	1.00	1.00	1.00
d2, Incremental Delay [s]	0.82	0.15	0.03	1.30	0.57	0.77	1.09	0.04	0.16	2.61	0.51	0.41
d3, Initial Queue Delay [s]	0.00	0.00	0.00	0.00	0.00	0.00	0.00	0.00	0.00	0.00	0.00	0.00
Rp, platoon ratio	1.00	1.00	1.00	1.00	1.00	1.00	1.00	1.00	1.00	1.00	1.00	1.00
PF, progression factor	1.00	1.00	1.00	1.00	1.00	1.00	1.00	1.00	1.00	1.00	1.00	1.00

**Lane Group Results**

X, volume / capacity	0.31	0.32	0.04	0.16	0.57	0.59	0.71	0.06	0.16	0.17	0.14	0.09
d, Delay for Lane Group [s/veh]	21.96	12.80	11.46	25.91	17.41	17.72	18.88	12.96	13.51	27.92	23.45	23.27
Lane Group LOS	C	B	B	C	B	B	B	B	B	C	C	C
Critical Lane Group	Yes	No	No	No	No	Yes	Yes	No	No	No	Yes	No
50th-Percentile Queue Length [veh/ln]	0.71	1.51	0.17	0.12	2.48	2.10	3.18	0.25	0.63	0.08	0.21	0.10
50th-Percentile Queue Length [ft/ln]	17.85	37.85	4.15	3.02	61.95	52.45	79.62	6.20	15.66	1.96	5.26	2.39
95th-Percentile Queue Length [veh/ln]	1.28	2.73	0.30	0.22	4.46	3.78	5.73	0.45	1.13	0.14	0.38	0.17
95th-Percentile Queue Length [ft/ln]	32.12	68.13	7.47	5.44	111.51	94.41	143.32	11.17	28.19	3.53	9.46	4.30



**Movement, Approach, & Intersection Results**

d_M, Delay for Movement [s/veh]	21.96	12.80	11.46	25.91	17.41	17.72	18.88	12.96	13.51	27.92	23.45	23.27
Movement LOS	C	B	B	C	B	B	B	B	B	C	C	C
d_A, Approach Delay [s/veh]	13.95			17.63			18.04			24.12		
Approach LOS	B			B			B			C		
d_I, Intersection Delay [s/veh]	17.05											
Intersection LOS	B											
Intersection V/C	0.493											

**Emissions**

Vehicle Miles Traveled [mph]	6.19	38.21	2.29	0.98	56.88	47.43	81.50	4.26	10.32	0.18	0.65	0.29
Stops [stops/h]	49.46	209.80	11.50	8.37	343.39	290.73	441.36	17.19	43.41	5.43	14.57	6.63
Fuel consumption [US gal/h]	0.82	3.78	0.21	0.13	6.10	5.13	8.22	0.36	0.88	0.07	0.19	0.09
CO [g/h]	57.23	264.02	14.94	9.36	426.06	358.93	574.76	24.97	61.83	4.60	13.49	6.03
NOx [g/h]	11.14	51.37	2.91	1.82	82.90	69.83	111.83	4.86	12.03	0.89	2.62	1.17
VOC [g/h]	13.26	61.19	3.46	2.17	98.74	83.19	133.21	5.79	14.33	1.07	3.13	1.40

**Other Modes**

g_Walk,mi, Effective Walk Time [s]	8.0		7.0		-5.8		8.0	
M_corner, Corner Circulation Area [ft <sup>2</sup> /ped]	0.00		0.00		0.00		0.00	
M_CW, Crosswalk Circulation Area [ft <sup>2</sup> /ped]	0.00		0.00		0.00		0.00	
d_p, Pedestrian Delay [s]	18.59		19.45		32.10		18.59	
I_p,int, Pedestrian LOS Score for Intersectio	2.606		2.850		2.655		2.129	
Crosswalk LOS	B		C		B		B	
s_b, Saturation Flow Rate of the bicycle lane	2000		2000		2000		2000	
c_b, Capacity of the bicycle lane [bicycles/h]	1925		1925		1155		1155	
d_b, Bicycle Delay [s]	0.04		0.04		4.64		4.64	
I_b,int, Bicycle LOS Score for Intersection	1.964		2.360		2.789		1.611	
Bicycle LOS	A		B		C		A	

**Sequence**

Ring 1	1	2	3	4	-	-	-	-	-	-	-	-	-	-	-
Ring 2	5	6	7	8	-	-	-	-	-	-	-	-	-	-	-
Ring 3	-	-	-	-	-	-	-	-	-	-	-	-	-	-	-
Ring 4	-	-	-	-	-	-	-	-	-	-	-	-	-	-	-



**Intersection Level Of Service Report**  
**Intersection 7: Fallon Road & Positano Parkway**

Control Type:	Signalized	Delay (sec / veh):	15.1
Analysis Method:	HCM 7th Edition	Level Of Service:	B
Analysis Period:	15 minutes	Volume to Capacity (v/c):	0.707

**Intersection Setup**

Name	Fallon Road		Fallon Road		Positano Parkway	
Approach	Northbound		Southbound		Westbound	
Lane Configuration	↑↑↑↔		↔↑↑↑		↔↔↔	
Turning Movement	Thru	Right	Left	Thru	Left	Right
Lane Width [ft]	12.00	12.00	12.00	12.00	12.00	12.00
No. of Lanes in Entry Pocket	0	1	1	0	1	1
Entry Pocket Length [ft]	100.00	225.00	325.00	100.00	375.00	425.00
No. of Lanes in Exit Pocket	0	0	0	0	0	0
Exit Pocket Length [ft]	0.00	0.00	0.00	0.00	0.00	0.00
Speed [mph]	30.00		30.00		30.00	
Grade [%]	0.00		0.00		0.00	
Curb Present	No		No		No	
Crosswalk	Yes		Yes		Yes	



**Volumes**

Name	Fallon Road		Fallon Road		Positano Parkway	
Base Volume Input [veh/h]	542	443	315	715	320	177
Base Volume Adjustment Factor	1.0000	1.0000	1.0000	1.0000	1.0000	1.0000
Heavy Vehicles Percentage [%]	0.20	0.00	0.00	1.50	0.00	0.00
Proportion of CAVs [%]	0.00					
Growth Factor	1.0000	1.0000	1.0000	1.0000	1.0000	1.0000
In-Process Volume [veh/h]	0	0	0	0	0	0
Site-Generated Trips [veh/h]	0	0	0	0	0	0
Diverted Trips [veh/h]	0	0	0	0	0	0
Pass-by Trips [veh/h]	0	0	0	0	0	0
Existing Site Adjustment Volume [veh/h]	0	0	0	0	0	0
Other Volume [veh/h]	0	0	0	0	0	0
Right Turn on Red Volume [veh/h]	0	0	0	0	0	0
Total Hourly Volume [veh/h]	542	443	315	715	320	177
Peak Hour Factor	0.9300	0.9300	0.9300	0.9300	0.9300	0.9300
Other Adjustment Factor	1.0000	1.0000	1.0000	1.0000	1.0000	1.0000
Total 15-Minute Volume [veh/h]	146	119	85	192	86	48
Total Analysis Volume [veh/h]	583	476	339	769	344	190
Presence of On-Street Parking	No	No	No	No	No	No
On-Street Parking Maneuver Rate [/h]	0	0	0	0	0	0
Local Bus Stopping Rate [/h]	0	0	0	0	0	0
v_do, Outbound Pedestrian Volume crossing	0		1		0	
v_di, Inbound Pedestrian Volume crossing m	0		0		1	
v_co, Outbound Pedestrian Volume crossing	0		0		1	
v_ci, Inbound Pedestrian Volume crossing mi	1		0		0	
v_ab, Corner Pedestrian Volume [ped/h]	0		0		0	
Bicycle Volume [bicycles/h]	0		0		0	



**Intersection Settings**

Located in CBD	No
Signal Coordination Group	-
Cycle Length [s]	90
Active Pattern	Free Running (No Pattern)
Coordination Type	<i>Free Running</i>
Actuation Type	<i>Fully actuated</i>
Offset [s]	0.0
Offset Reference	Lead Green - Beginning of First Green
Permissive Mode	SingleBand
Lost time [s]	9.00

**Phasing & Timing (Basic)**

Control Type	Permissive	Permissive	Protected	Permissive	Permissive	Permissive
Signal Group	4	0	7	8	6	0
Auxiliary Signal Groups						
Maximum Green [s]	30	0	20	30	24	0
Amber [s]	4.3	0.0	3.5	4.3	4.0	0.0
All red [s]	1.0	0.0	1.0	1.0	1.0	0.0
Walk [s]	0	0	0	4	4	0
Pedestrian Clearance [s]	0	0	0	20	34	0
Delayed Vehicle Green [s]	0.0	0.0	0.0	0.0	0.0	0.0
Rest In Walk	No			No	No	
I1, Start-Up Lost Time [s]	2.0	0.0	2.0	2.0	2.0	0.0
I2, Clearance Lost Time [s]	2.0	0.0	2.0	2.0	2.0	0.0
Detector Location [ft]	0.0	0.0	0.0	0.0	0.0	0.0
Detector Length [ft]	20.0	0.0	20.0	20.0	20.0	0.0
I, Upstream Filtering Factor	1.00	1.00	1.00	1.00	1.00	1.00

**Phasing & Timing: Free Running (No Pattern)**

Split [s]	14	0	9	14	9	0
Lead / Lag	-	-	Lead	-	Lead	-
Minimum Green [s]	10	0	5	10	5	0
Vehicle Extension [s]	3.0	0.0	3.0	3.0	3.0	0.0
Minimum Recall	Yes		No	Yes	No	
Maximum Recall	No		No	No	No	
Pedestrian Recall	No		No	No	No	

**Exclusive Pedestrian Phase**

Pedestrian Signal Group	0
Pedestrian Walk [s]	0
Pedestrian Clearance [s]	0





**Lane Group Calculations**

Lane Group	C	R	L	C	L	R
C, Cycle Length [s]	59	59	59	59	59	59
L, Total Lost Time per Cycle [s]	4.00	4.00	4.00	4.00	4.00	4.00
l1_p, Permitted Start-Up Lost Time [s]	0.00	0.00	0.00	0.00	0.00	0.00
l2, Clearance Lost Time [s]	2.00	2.00	2.00	2.00	2.00	2.00
g_i, Effective Green Time [s]	22	22	14	40	11	11
g / C, Green / Cycle	0.38	0.38	0.23	0.67	0.19	0.19
(v / s)_i Volume / Saturation Flow Rate	0.11	0.29	0.19	0.15	0.10	0.12
s, saturation flow rate [veh/h]	5167	1615	1810	5114	3514	1612
c, Capacity [veh/h]	1940	606	417	3444	674	309
d1, Uniform Delay [s]	13.06	16.42	21.62	3.73	21.49	21.97
k, delay calibration	0.11	0.14	0.11	0.11	0.11	0.11
l, Upstream Filtering Factor	1.00	1.00	1.00	1.00	1.00	1.00
d2, Incremental Delay [s]	0.09	3.05	4.00	0.03	0.60	1.98
d3, Initial Queue Delay [s]	0.00	0.00	0.00	0.00	0.00	0.00
Rp, platoon ratio	1.00	1.00	1.00	1.00	1.00	1.00
PF, progression factor	1.00	1.00	1.00	1.00	1.00	1.00

**Lane Group Results**

X, volume / capacity	0.30	0.79	0.81	0.22	0.51	0.61
d, Delay for Lane Group [s/veh]	13.14	19.47	25.62	3.76	22.09	23.95
Lane Group LOS	B	B	C	A	C	C
Critical Lane Group	No	Yes	Yes	No	No	Yes
50th-Percentile Queue Length [veh/ln]	1.64	5.51	4.55	0.76	2.04	2.41
50th-Percentile Queue Length [ft/ln]	40.92	137.71	113.63	19.08	51.07	60.35
95th-Percentile Queue Length [veh/ln]	2.95	9.36	8.04	1.37	3.68	4.34
95th-Percentile Queue Length [ft/ln]	73.65	233.94	201.04	34.35	91.93	108.62

**Movement, Approach, & Intersection Results**

d_M, Delay for Movement [s/veh]	13.14	19.47	25.62	3.76	22.09	23.95
Movement LOS	B	B	C	A	C	C
d_A, Approach Delay [s/veh]	15.99		10.45		22.75	
Approach LOS	B		B		C	
d_I, Intersection Delay [s/veh]	15.05					
Intersection LOS	B					
Intersection V/C	0.707					

**Emissions**

Vehicle Miles Traveled [mph]	146.63	119.72	29.74	67.47	41.25	22.78
Stops [stops/h]	298.26	334.61	276.10	139.09	248.20	146.63
Fuel consumption [US gal/h]	9.24	8.66	4.52	4.13	4.62	2.67
CO [g/h]	646.12	605.58	315.77	288.99	322.65	186.92
NOx [g/h]	125.71	117.82	61.44	56.23	62.78	36.37
VOC [g/h]	149.75	140.35	73.18	66.98	74.78	43.32

**Other Modes**

g_Walk,mi, Effective Walk Time [s]	8.0		8.0		8.7	
M_corner, Corner Circulation Area [ft <sup>2</sup> /ped]	0.00		0.00		0.00	
M_CW, Crosswalk Circulation Area [ft <sup>2</sup> /ped]	0.00		0.00		0.00	
d_p, Pedestrian Delay [s]	22.17		22.17		21.57	
I_p,int, Pedestrian LOS Score for Intersectio	2.878		2.837		2.440	
Crosswalk LOS	C		C		B	
s_b, Saturation Flow Rate of the bicycle lane	2000		2000		2000	
c_b, Capacity of the bicycle lane [bicycles/h]	1012		1012		810	
d_b, Bicycle Delay [s]	7.23		7.23		10.49	
I_b,int, Bicycle LOS Score for Intersection	2.142		2.169		1.560	
Bicycle LOS	B		B		A	

**Sequence**

Ring 1	-	-	-	8	-	-	-	-	-	-	-	-	-	-	-	-
Ring 2	-	6	7	4	-	-	-	-	-	-	-	-	-	-	-	-
Ring 3	-	-	-	-	-	-	-	-	-	-	-	-	-	-	-	-
Ring 4	-	-	-	-	-	-	-	-	-	-	-	-	-	-	-	-



**Intersection Level Of Service Report**  
**Intersection 8: Fallon Road & Central Parkway**

Control Type:	Signalized	Delay (sec / veh):	26.3
Analysis Method:	HCM 7th Edition	Level Of Service:	C
Analysis Period:	15 minutes	Volume to Capacity (v/c):	0.623

**Intersection Setup**

Name	Fallon Road			Fallon Road			Central Parkway			Central Parkway		
Approach	Northbound			Southbound			Eastbound			Westbound		
Lane Configuration	⇐⇐⇐			⇐⇐⇐			⇐⇐⇐			⇐⇐⇐		
Turning Movement	Left	Thru	Right	Left	Thru	Right	Left	Thru	Right	Left	Thru	Right
Lane Width [ft]	12.00	12.00	12.00	12.00	12.00	12.00	12.00	12.00	12.00	12.00	12.00	12.00
No. of Lanes in Entry Pocket	2	0	1	1	0	1	2	0	2	2	0	1
Entry Pocket Length [ft]	300.00	100.00	255.00	295.00	100.00	245.00	350.00	100.00	230.00	250.00	100.00	250.00
No. of Lanes in Exit Pocket	0	0	0	0	0	2	0	0	0	0	0	0
Exit Pocket Length [ft]	0.00	0.00	0.00	0.00	0.00	500.00	0.00	0.00	0.00	0.00	0.00	0.00
Speed [mph]	40.00			30.00			25.00			30.00		
Grade [%]	0.00			0.00			0.00			0.00		
Curb Present	Yes			Yes			Yes			Yes		
Crosswalk	Yes			Yes			Yes			Yes		



**Volumes**

Name	Fallon Road			Fallon Road			Central Parkway			Central Parkway		
Base Volume Input [veh/h]	161	914	188	32	1088	108	161	76	290	195	40	35
Base Volume Adjustment Factor	1.0000	1.0000	1.0000	1.0000	1.0000	1.0000	1.0000	1.0000	1.0000	1.0000	1.0000	1.0000
Heavy Vehicles Percentage [%]	0.70	0.10	0.00	0.00	0.40	0.00	0.00	0.00	0.00	0.00	0.00	0.00
Proportion of CAVs [%]	0.00											
Growth Factor	1.0000	1.0000	1.0000	1.0000	1.0000	1.0000	1.0000	1.0000	1.0000	1.0000	1.0000	1.0000
In-Process Volume [veh/h]	0	0	0	0	0	0	0	0	0	0	0	0
Site-Generated Trips [veh/h]	0	0	0	0	0	0	0	0	0	0	0	0
Diverted Trips [veh/h]	0	0	0	0	0	0	0	0	0	0	0	0
Pass-by Trips [veh/h]	0	0	0	0	0	0	0	0	0	0	0	0
Existing Site Adjustment Volume [veh/h]	0	0	0	0	0	0	0	0	0	0	0	0
Other Volume [veh/h]	0	0	0	0	0	0	0	0	0	0	0	0
Right Turn on Red Volume [veh/h]	0	0	0	0	0	0	0	0	0	0	0	0
Total Hourly Volume [veh/h]	161	914	188	32	1088	108	161	76	290	195	40	35
Peak Hour Factor	0.9200	0.9200	0.9200	0.9200	0.9200	0.9200	0.9200	0.9200	0.9200	0.9200	0.9200	0.9200
Other Adjustment Factor	1.0000	1.0000	1.0000	1.0000	1.0000	1.0000	1.0000	1.0000	1.0000	1.0000	1.0000	1.0000
Total 15-Minute Volume [veh/h]	44	248	51	9	296	29	44	21	79	53	11	10
Total Analysis Volume [veh/h]	175	993	204	35	1183	117	175	83	315	212	43	38
Presence of On-Street Parking	No		No	No		No	No		No	No		No
On-Street Parking Maneuver Rate [/h]	0	0	0	0	0	0	0	0	0	0	0	0
Local Bus Stopping Rate [/h]	0	0	0	0	0	0	0	0	0	0	0	0
v_do, Outbound Pedestrian Volume crossing	1			4			4			1		
v_di, Inbound Pedestrian Volume crossing m	1			4			4			1		
v_co, Outbound Pedestrian Volume crossing	2			6			1			5		
v_ci, Inbound Pedestrian Volume crossing mi	1			5			2			6		
v_ab, Corner Pedestrian Volume [ped/h]	0			0			0			0		
Bicycle Volume [bicycles/h]	0			1			0			0		



**Intersection Settings**

Located in CBD	No
Signal Coordination Group	-
Cycle Length [s]	90
Active Pattern	Free Running (No Pattern)
Coordination Type	<i>Free Running</i>
Actuation Type	<i>Fully actuated</i>
Offset [s]	0.0
Offset Reference	Lead Green - Beginning of First Green
Permissive Mode	SingleBand
Lost time [s]	12.00

**Phasing & Timing (Basic)**

Control Type	Protecte	Permiss	Permiss	Protecte	Permiss	Permiss	Protecte	Permiss	Permiss	Protecte	Permiss	Permiss
Signal Group	3	8	0	7	4	0	5	2	0	1	6	0
Auxiliary Signal Groups												
Maximum Green [s]	20	30	0	20	30	0	20	30	0	20	30	0
Amber [s]	3.5	4.3	0.0	3.0	4.3	0.0	3.0	4.0	0.0	3.0	4.0	0.0
All red [s]	1.0	1.0	0.0	1.0	1.0	0.0	1.0	1.0	0.0	1.0	1.0	0.0
Walk [s]	0	4	0	0	4	0	0	4	0	0	4	0
Pedestrian Clearance [s]	0	28	0	0	34	0	0	42	0	0	41	0
Delayed Vehicle Green [s]	0.0	0.0	0.0	0.0	0.0	0.0	0.0	0.0	0.0	0.0	0.0	0.0
Rest In Walk		No			No			No			No	
I1, Start-Up Lost Time [s]	2.0	2.0	0.0	2.0	2.0	0.0	2.0	2.0	0.0	2.0	2.0	0.0
I2, Clearance Lost Time [s]	2.0	2.0	0.0	2.0	2.0	0.0	2.0	2.0	0.0	2.0	2.0	0.0
Detector Location [ft]	0.0	0.0	0.0	0.0	0.0	0.0	0.0	0.0	0.0	0.0	0.0	0.0
Detector Length [ft]	20.0	20.0	0.0	0.0	0.0	0.0	20.0	20.0	0.0	20.0	20.0	0.0
I, Upstream Filtering Factor	1.00	1.00	1.00	1.00	1.00	1.00	1.00	1.00	1.00	1.00	1.00	1.00

**Phasing & Timing: Free Running (No Pattern)**

Split [s]	0	0	0	0	0	0	0	0	0	0	0	0
Lead / Lag	Lead	-	-	Lead	-	-	Lead	-	-	Lead	-	-
Minimum Green [s]	10	12	0	10	12	0	10	12	0	10	12	0
Vehicle Extension [s]	2.0	4.0	0.0	2.0	4.0	0.0	2.0	4.0	0.0	2.0	4.0	0.0
Minimum Recall	No	Yes		No	Yes		No	No		No	No	
Maximum Recall	No	No		No	No		No	No		No	No	
Pedestrian Recall	No	No		No	No		No	No		No	No	

**Exclusive Pedestrian Phase**

Pedestrian Signal Group	0
Pedestrian Walk [s]	0
Pedestrian Clearance [s]	0



**Lane Group Calculations**

Lane Group	L	C	R	L	C	R	L	C	R	L	C	R
C, Cycle Length [s]	85	85	85	85	85	85	85	85	85	85	85	85
L, Total Lost Time per Cycle [s]	4.00	4.00	4.00	4.00	4.00	4.00	4.00	4.00	4.00	4.00	4.00	4.00
l1_p, Permitted Start-Up Lost Time [s]	0.00	0.00	0.00	0.00	0.00	0.00	0.00	0.00	0.00	0.00	0.00	0.00
l2, Clearance Lost Time [s]	2.00	2.00	2.00	2.00	2.00	2.00	2.00	2.00	2.00	2.00	2.00	2.00
g_i, Effective Green Time [s]	10	32	32	6	27	27	10	21	21	10	21	21
g / C, Green / Cycle	0.12	0.38	0.38	0.07	0.32	0.32	0.12	0.25	0.25	0.12	0.25	0.25
(v / s)_i Volume / Saturation Flow Rate	0.05	0.19	0.13	0.02	0.23	0.07	0.05	0.04	0.20	0.06	0.02	0.02
s, saturation flow rate [veh/h]	3495	5172	1611	1810	5159	1583	3514	1900	1609	3514	1900	1594
c, Capacity [veh/h]	425	1957	610	121	1669	512	407	475	402	411	477	400
d1, Uniform Delay [s]	34.57	20.35	18.82	37.81	25.27	21.00	35.03	25.04	29.74	35.34	24.43	24.45
k, delay calibration	0.04	0.15	0.15	0.04	0.15	0.15	0.04	0.15	0.17	0.04	0.15	0.15
l, Upstream Filtering Factor	1.00	1.00	1.00	1.00	1.00	1.00	1.00	1.00	1.00	1.00	1.00	1.00
d2, Incremental Delay [s]	0.24	0.29	0.46	0.49	0.80	0.32	0.27	0.25	5.16	0.37	0.12	0.15
d3, Initial Queue Delay [s]	0.00	0.00	0.00	0.00	0.00	0.00	0.00	0.00	0.00	0.00	0.00	0.00
Rp, platoon ratio	1.00	1.00	1.00	1.00	1.00	1.00	1.00	1.00	1.00	1.00	1.00	1.00
PF, progression factor	1.00	1.00	1.00	1.00	1.00	1.00	1.00	1.00	1.00	1.00	1.00	1.00

**Lane Group Results**

X, volume / capacity	0.41	0.51	0.33	0.29	0.71	0.23	0.43	0.17	0.78	0.52	0.09	0.09
d, Delay for Lane Group [s/veh]	34.81	20.65	19.28	38.29	26.08	21.32	35.29	25.28	34.90	35.71	24.54	24.60
Lane Group LOS	C	C	B	D	C	C	D	C	C	D	C	C
Critical Lane Group	Yes	No	No	No	Yes	No	No	No	Yes	Yes	No	No
50th-Percentile Queue Length [veh/ln]	1.62	4.70	2.72	0.70	6.82	1.70	1.69	1.34	6.47	2.05	0.67	0.59
50th-Percentile Queue Length [ft/ln]	40.41	117.40	68.09	17.50	170.55	42.42	42.31	33.49	161.72	51.20	16.67	14.81
95th-Percentile Queue Length [veh/ln]	2.91	8.25	4.90	1.26	11.11	3.05	3.05	2.41	10.64	3.69	1.20	1.07
95th-Percentile Queue Length [ft/ln]	72.75	206.24	122.57	31.50	277.64	76.36	76.17	60.27	266.00	92.16	30.00	26.65



**Movement, Approach, & Intersection Results**

d_M, Delay for Movement [s/veh]	34.81	20.65	19.28	38.29	26.08	21.32	35.29	25.28	34.90	35.71	24.54	24.60
Movement LOS	C	C	B	D	C	C	D	C	C	D	C	C
d_A, Approach Delay [s/veh]	22.25			25.98			33.63			32.63		
Approach LOS	C			C			C			C		
d_I, Intersection Delay [s/veh]	26.32											
Intersection LOS	C											
Intersection V/C	0.623											

**Emissions**

Vehicle Miles Traveled [mph]	46.34	262.92	54.01	8.80	297.53	29.43	15.29	7.25	27.53	48.20	9.78	8.64
Stops [stops/h]	136.94	596.67	115.36	29.65	866.84	71.87	143.38	56.73	273.98	173.48	28.24	25.09
Fuel consumption [US gal/h]	4.24	19.45	3.87	0.80	23.32	2.12	2.49	0.97	4.53	4.48	0.77	0.68
CO [g/h]	296.70	1359.65	270.41	55.84	1629.76	147.91	174.38	67.86	316.38	313.36	54.04	47.84
NOx [g/h]	57.73	264.54	52.61	10.87	317.09	28.78	33.93	13.20	61.56	60.97	10.52	9.31
VOC [g/h]	68.76	315.11	62.67	12.94	377.71	34.28	40.41	15.73	73.32	72.62	12.53	11.09

**Other Modes**

g_Walk,mi, Effective Walk Time [s]	8.0			8.0			8.0			8.0		
M_corner, Corner Circulation Area [ft <sup>2</sup> /ped]	0.00			0.00			0.00			0.00		
M_CW, Crosswalk Circulation Area [ft <sup>2</sup> /ped]	0.00			0.00			0.00			0.00		
d_p, Pedestrian Delay [s]	34.87			34.87			34.87			34.87		
I_p,int, Pedestrian LOS Score for Intersectio	3.367			3.214			2.699			2.420		
Crosswalk LOS	C			C			B			B		
s_b, Saturation Flow Rate of the bicycle lane	2000			2000			2000			2000		
c_b, Capacity of the bicycle lane [bicycles/h]	706			706			706			706		
d_b, Bicycle Delay [s]	17.79			17.80			17.79			17.79		
I_b,int, Bicycle LOS Score for Intersection	2.314			2.294			2.505			2.043		
Bicycle LOS	B			B			B			B		

**Sequence**

Ring 1	1	2	3	4	-	-	-	-	-	-	-	-	-	-	-
Ring 2	5	6	7	8	-	-	-	-	-	-	-	-	-	-	-
Ring 3	-	-	-	-	-	-	-	-	-	-	-	-	-	-	-
Ring 4	-	-	-	-	-	-	-	-	-	-	-	-	-	-	-

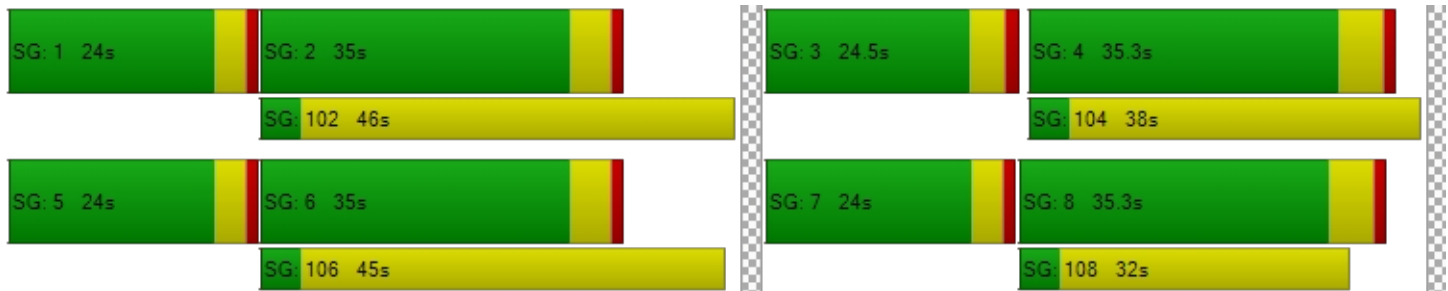

**Intersection Level Of Service Report**  
**Intersection 9: Fallon Road & Dublin Boulevard**

Control Type:	Signalized	Delay (sec / veh):	83.4
Analysis Method:	HCM 7th Edition	Level Of Service:	F
Analysis Period:	15 minutes	Volume to Capacity (v/c):	0.887

**Intersection Setup**

Name	Fallon Road			Fallon Road			Dublin Boulevard			Dublin Boulevard		
Approach	Northbound			Southbound			Eastbound			Westbound		
Lane Configuration												
Turning Movement	Left	Thru	Right	Left	Thru	Right	Left	Thru	Right	Left	Thru	Right
Lane Width [ft]	12.00	12.00	12.00	12.00	12.00	12.00	12.00	12.00	12.00	12.00	12.00	12.00
No. of Lanes in Entry Pocket	3	0	2	2	0	1	2	0	2	2	0	1
Entry Pocket Length [ft]	430.00	100.00	100.00	140.00	100.00	225.00	400.00	100.00	400.00	100.00	100.00	100.00
No. of Lanes in Exit Pocket	0	0	1	0	0	1	0	0	1	0	0	1
Exit Pocket Length [ft]	0.00	0.00	100.00	0.00	0.00	100.00	0.00	0.00	500.00	0.00	0.00	100.00
Speed [mph]	45.00			45.00			45.00			45.00		
Grade [%]	0.00			0.00			0.00			0.00		
Curb Present	Yes			Yes			Yes			Yes		
Crosswalk	No			No			Yes			Yes		





**Volumes**

Name	Fallon Road			Fallon Road			Dublin Boulevard			Dublin Boulevard		
Base Volume Input [veh/h]	372	903	288	304	1117	151	222	1719	372	1112	126	191
Base Volume Adjustment Factor	1.0000	1.0000	1.0000	1.0000	1.0000	1.0000	1.0000	1.0000	1.0000	1.0000	1.0000	1.0000
Heavy Vehicles Percentage [%]	3.70	0.30	4.00	1.00	0.70	1.60	0.00	4.00	2.20	1.00	1.00	1.00
Proportion of CAVs [%]	0.00											
Growth Factor	1.0000	1.0000	1.0000	1.0000	1.0000	1.0000	1.0000	1.0000	1.0000	1.0000	1.0000	1.0000
In-Process Volume [veh/h]	0	0	0	0	0	0	0	0	0	0	0	0
Site-Generated Trips [veh/h]	0	0	0	0	0	0	0	0	0	0	0	0
Diverted Trips [veh/h]	0	0	0	0	0	0	0	0	0	0	0	0
Pass-by Trips [veh/h]	0	0	0	0	0	0	0	0	0	0	0	0
Existing Site Adjustment Volume [veh/h]	0	0	0	0	0	0	0	0	0	0	0	0
Other Volume [veh/h]	0	0	0	0	0	0	0	0	0	0	0	0
Right Turn on Red Volume [veh/h]	0	0	0	0	0	0	0	0	0	0	0	0
Total Hourly Volume [veh/h]	372	903	288	304	1117	151	222	1719	372	1112	126	191
Peak Hour Factor	0.9400	0.9400	0.9400	0.9400	0.9400	0.9400	0.9400	0.9400	0.9400	0.9400	0.9400	0.9400
Other Adjustment Factor	1.0000	1.0000	1.0000	1.0000	1.0000	1.0000	1.0000	1.0000	1.0000	1.0000	1.0000	1.0000
Total 15-Minute Volume [veh/h]	99	240	77	81	297	40	59	457	99	296	34	51
Total Analysis Volume [veh/h]	396	961	306	323	1188	161	236	1829	396	1183	134	203
Presence of On-Street Parking	No		No	No		No	No		No	No		No
On-Street Parking Maneuver Rate [/h]	0	0	0	0	0	0	0	0	0	0	0	0
Local Bus Stopping Rate [/h]	0	0	0	0	0	0	0	0	0	0	0	0
v_do, Outbound Pedestrian Volume crossing	0			0			0			0		
v_di, Inbound Pedestrian Volume crossing m	0			0			0			0		
v_co, Outbound Pedestrian Volume crossing	0			2			3			0		
v_ci, Inbound Pedestrian Volume crossing mi	0			3			2			0		
v_ab, Corner Pedestrian Volume [ped/h]	0			0			0			0		
Bicycle Volume [bicycles/h]	0			1			0			0		



**Intersection Settings**

Located in CBD	No
Signal Coordination Group	-
Cycle Length [s]	235
Active Pattern	Pattern 1
Coordination Type	Time of Day Pattern Isolated
Actuation Type	Fully actuated
Offset [s]	0.0
Offset Reference	Lead Green - Beginning of First Green
Permissive Mode	SingleBand
Lost time [s]	12.00

**Phasing & Timing (Basic)**

Control Type	Protecte	Permiss	Permiss	Protecte	Permiss	Permiss	Protecte	Permiss	Overlap	Protecte	Permiss	Permiss
Signal Group	3	8	0	7	4	0	5	2	2	1	6	0
Auxiliary Signal Groups									2,3			
Maximum Green [s]	30	30	0	12	30	0	30	30	30	12	12	0
Amber [s]	4.3	4.7	0.0	4.3	4.7	0.0	4.3	4.3	4.3	3.0	4.8	0.0
All red [s]	1.0	1.0	0.0	1.0	1.0	0.0	1.0	1.0	1.0	1.0	1.0	0.0
Walk [s]	0	0	0	0	4	0	0	0	0	0	0	0
Pedestrian Clearance [s]	0	0	0	0	41	0	0	0	0	0	0	0
Delayed Vehicle Green [s]	0.0	0.0	0.0	0.0	0.0	0.0	0.0	0.0	0.0	0.0	0.0	0.0
Rest In Walk		No			No			No			No	
I1, Start-Up Lost Time [s]	2.0	2.0	0.0	2.0	2.0	0.0	2.0	2.0	2.0	2.0	2.0	0.0
I2, Clearance Lost Time [s]	2.0	2.0	0.0	2.0	2.0	0.0	2.0	2.0	2.0	2.0	2.0	0.0
Detector Location [ft]	0.0	0.0	0.0	0.0	0.0	0.0	0.0	0.0	0.0	0.0	0.0	0.0
Detector Length [ft]	0.0	0.0	0.0	0.0	0.0	0.0	20.0	20.0	20.0	0.0	0.0	0.0
I, Upstream Filtering Factor	1.00	1.00	1.00	1.00	1.00	1.00	1.00	1.00	1.00	1.00	1.00	1.00

**Phasing & Timing: Pattern 1**

Split [s]	21	50	0	26	55	0	127	82	82	77	32	0
Lead / Lag	Lead	-	-	Lead	-	-	Lead	-	-	Lead	-	-
Minimum Green [s]	10	12	0	10	12	0	10	12	12	10	10	0
Vehicle Extension [s]	2.0	4.0	0.0	2.0	4.0	0.0	2.0	4.0	4.0	2.0	2.0	0.0
Minimum Recall	No	Yes		No	Yes		No	No	No	No	No	
Maximum Recall	No	No		No	No		No	No	No	No	No	
Pedestrian Recall	No	No		No	No		No	No	No	No	No	

**Exclusive Pedestrian Phase**

Pedestrian Signal Group	0
Pedestrian Walk [s]	0
Pedestrian Clearance [s]	0



**Lane Group Calculations**

Lane Group	L	C	R	L	C	R	L	C	R	L	C	R
C, Cycle Length [s]	235	235	235	235	235	235	235	235	235	235	235	235
L, Total Lost Time per Cycle [s]	4.00	4.00	4.00	4.00	4.00	4.00	4.00	4.00	4.00	4.00	4.00	4.00
l1_p, Permitted Start-Up Lost Time [s]	0.00	0.00	0.00	0.00	0.00	0.00	0.00	0.00	0.00	0.00	0.00	0.00
l2, Clearance Lost Time [s]	2.00	2.00	2.00	2.00	2.00	2.00	2.00	2.00	0.00	2.00	2.00	2.00
g_i, Effective Green Time [s]	17	46	46	22	51	51	19	94	116	56	131	131
g / C, Green / Cycle	0.07	0.20	0.20	0.10	0.22	0.22	0.08	0.40	0.49	0.24	0.56	0.56
(v / s)_i Volume / Saturation Flow Rate	0.08	0.14	0.11	0.09	0.17	0.10	0.07	0.36	0.14	0.23	0.03	0.13
s, saturation flow rate [veh/h]	5117	6884	2768	3486	6863	1563	3514	5012	2809	5230	5135	1602
c, Capacity [veh/h]	376	1352	544	331	1493	340	288	2013	1367	1250	2870	895
d1, Uniform Delay [s]	108.85	88.20	85.32	106.10	86.98	80.00	106.18	66.23	36.03	87.94	23.48	26.18
k, delay calibration	0.04	0.50	0.50	0.04	0.50	0.50	0.04	0.15	0.15	0.04	0.04	0.04
l, Upstream Filtering Factor	1.00	1.00	1.00	1.00	1.00	1.00	1.00	1.00	1.00	1.00	1.00	1.00
d2, Incremental Delay [s]	29.48	3.20	4.18	9.58	4.47	4.66	2.23	2.57	0.17	1.89	0.00	0.05
d3, Initial Queue Delay [s]	0.00	0.00	0.00	0.00	0.00	0.00	0.00	0.00	0.00	0.00	0.00	0.00
Rp, platoon ratio	1.00	1.00	1.00	1.00	1.00	1.00	1.00	1.00	1.00	1.00	1.00	1.00
PF, progression factor	1.00	1.00	1.00	1.00	1.00	1.00	1.00	1.00	1.00	1.00	1.00	1.00

**Lane Group Results**

X, volume / capacity	1.05	0.71	0.56	0.98	0.80	0.47	0.82	0.91	0.29	0.95	0.05	0.23
d, Delay for Lane Group [s/veh]	138.33	91.40	89.50	115.68	91.45	84.67	108.41	68.80	36.19	89.83	23.48	26.23
Lane Group LOS	F	F	F	F	F	F	F	E	D	F	C	C
Critical Lane Group	Yes	No	No	No	Yes	No	No	Yes	No	Yes	No	No
50th-Percentile Queue Length [veh/ln]	8.73	13.96	8.73	10.32	17.53	8.95	7.22	34.55	6.93	23.72	1.16	5.88
50th-Percentile Queue Length [ft/ln]	218.36	348.95	218.23	257.97	438.33	223.78	180.49	863.81	173.20	592.94	28.95	146.94
95th-Percentile Queue Length [veh/ln]	13.83	20.08	13.57	15.59	24.40	13.86	11.63	44.19	11.24	31.70	2.08	9.85
95th-Percentile Queue Length [ft/ln]	345.67	502.12	339.36	389.67	610.01	346.45	290.65	1104.81	281.12	792.61	52.11	246.34



**Movement, Approach, & Intersection Results**

d_M, Delay for Movement [s/veh]	138.33	91.40	89.50	115.68	91.45	84.67	108.41	68.80	36.19	89.83	23.48	26.23
Movement LOS	F	F	F	F	F	F	F	E	D	F	C	C
d_A, Approach Delay [s/veh]	102.23			95.48			67.35			75.49		
Approach LOS	F			F			E			E		
d_I, Intersection Delay [s/veh]	83.40											
Intersection LOS	F											
Intersection V/C	0.887											

**Emissions**

Vehicle Miles Traveled [mph]	53.19	129.07	41.10	85.52	314.55	42.63	283.94	2200.57	476.45	265.48	30.07	45.55
Stops [stops/h]	401.40	855.29	267.44	316.15	1074.37	137.13	221.19	1587.93	212.26	1090.00	53.22	90.04
Fuel consumption [US gal/h]	17.96	32.93	10.31	14.46	46.25	5.94	17.69	120.78	21.89	44.27	2.33	3.76
CO [g/h]	1255.36	2301.77	720.40	1011.06	3232.59	415.18	1236.45	8442.31	1529.91	3094.75	163.05	263.14
NOx [g/h]	244.25	447.84	140.16	196.72	628.94	80.78	240.57	1642.57	297.67	602.13	31.72	51.20
VOC [g/h]	290.94	533.46	166.96	234.32	749.18	96.22	286.56	1956.59	354.57	717.24	37.79	60.98

**Other Modes**

g_Walk,mi, Effective Walk Time [s]	0.0			0.0			8.0			44.3		
M_corner, Corner Circulation Area [ft <sup>2</sup> /ped]	0.00			0.00			0.00			0.00		
M_CW, Crosswalk Circulation Area [ft <sup>2</sup> /ped]	0.00			0.00			318.85			0.00		
d_p, Pedestrian Delay [s]	0.00			0.00			109.64			77.38		
I_p,int, Pedestrian LOS Score for Intersectio	0.000			0.000			3.473			3.580		
Crosswalk LOS	F			F			C			D		
s_b, Saturation Flow Rate of the bicycle lane	2000			2000			2000			2000		
c_b, Capacity of the bicycle lane [bicycles/h]	377			420			653			223		
d_b, Bicycle Delay [s]	77.38			73.41			53.32			92.76		
I_b,int, Bicycle LOS Score for Intersection	2.246			2.249			2.913			2.396		
Bicycle LOS	B			B			C			B		

**Sequence**

Ring 1	1	2	3	4	-	-	-	-	-	-	-	-	-	-	-
Ring 2	5	6	7	8	-	-	-	-	-	-	-	-	-	-	-
Ring 3	-	-	-	-	-	-	-	-	-	-	-	-	-	-	-
Ring 4	-	-	-	-	-	-	-	-	-	-	-	-	-	-	-



**Intersection Level Of Service Report**  
**Intersection 10: Fallon Road & Fallon Gateway**

Control Type:	Signalized	Delay (sec / veh):	42.4
Analysis Method:	HCM 7th Edition	Level Of Service:	D
Analysis Period:	15 minutes	Volume to Capacity (v/c):	0.728

**Intersection Setup**

Name	Fallon Road			Fallon Road			Fallon Gateway					
Approach	Northbound			Southbound			Eastbound			Westbound		
Lane Configuration	[Diagram]			[Diagram]			[Diagram]			[Diagram]		
Turning Movement	Left	Thru	Right	Left	Thru	Right	Left	Thru	Right	Left	Thru	Right
Lane Width [ft]	12.00	12.00	12.00	12.00	12.00	12.00	12.00	12.00	12.00	12.00	12.00	12.00
No. of Lanes in Entry Pocket	2	0	1	1	0	1	1	0	1	1	0	1
Entry Pocket Length [ft]	275.00	100.00	100.00	100.00	100.00	100.00	210.00	100.00	210.00	100.00	100.00	100.00
No. of Lanes in Exit Pocket	0	0	2	0	0	0	0	0	0	0	0	0
Exit Pocket Length [ft]	0.00	0.00	100.00	0.00	0.00	0.00	0.00	0.00	0.00	0.00	0.00	0.00
Speed [mph]	45.00			40.00			25.00			30.00		
Grade [%]	0.00			0.00			0.00			0.00		
Curb Present	Yes			Yes			Yes			No		
Crosswalk	No			No			Yes			Yes		



**Volumes**

Name	Fallon Road			Fallon Road			Fallon Gateway					
Base Volume Input [veh/h]	308	1397	163	113	2135	108	62	7	304	334	7	115
Base Volume Adjustment Factor	1.0000	1.0000	1.0000	1.0000	1.0000	1.0000	1.0000	1.0000	1.0000	1.0000	1.0000	1.0000
Heavy Vehicles Percentage [%]	1.00	0.60	2.00	2.00	1.30	1.00	0.00	2.00	1.30	2.00	2.00	2.00
Proportion of CAVs [%]	0.00											
Growth Factor	1.0000	1.0000	1.0000	1.0000	1.0000	1.0000	1.0000	1.0000	1.0000	1.0000	1.0000	1.0000
In-Process Volume [veh/h]	0	0	0	0	0	0	0	0	0	0	0	0
Site-Generated Trips [veh/h]	0	0	0	0	0	0	0	0	0	0	0	0
Diverted Trips [veh/h]	0	0	0	0	0	0	0	0	0	0	0	0
Pass-by Trips [veh/h]	0	0	0	0	0	0	0	0	0	0	0	0
Existing Site Adjustment Volume [veh/h]	0	0	0	0	0	0	0	0	0	0	0	0
Other Volume [veh/h]	0	0	0	0	0	0	0	0	0	0	0	0
Right Turn on Red Volume [veh/h]	0	0	0	0	0	0	0	0	0	0	0	0
Total Hourly Volume [veh/h]	308	1397	163	113	2135	108	62	7	304	334	7	115
Peak Hour Factor	0.9400	0.9400	1.0000	1.0000	0.9400	0.9400	0.9400	1.0000	0.9400	1.0000	1.0000	1.0000
Other Adjustment Factor	1.0000	1.0000	1.0000	1.0000	1.0000	1.0000	1.0000	1.0000	1.0000	1.0000	1.0000	1.0000
Total 15-Minute Volume [veh/h]	82	372	41	28	568	29	16	2	81	84	2	29
Total Analysis Volume [veh/h]	328	1486	163	113	2271	115	66	7	323	334	7	115
Presence of On-Street Parking	No		No	No		No	No		No	No		No
On-Street Parking Maneuver Rate [/h]	0	0	0	0	0	0	0	0	0	0	0	0
Local Bus Stopping Rate [/h]	0	0	0	0	0	0	0	0	0	0	0	0
v_do, Outbound Pedestrian Volume crossing	0			0			0			0		
v_di, Inbound Pedestrian Volume crossing m	0			0			0			0		
v_co, Outbound Pedestrian Volume crossing	0			0			0			0		
v_ci, Inbound Pedestrian Volume crossing mi	0			0			0			0		
v_ab, Corner Pedestrian Volume [ped/h]	0			0			0			0		
Bicycle Volume [bicycles/h]	0			0			0			0		



**Intersection Settings**

Located in CBD	No
Signal Coordination Group	-
Cycle Length [s]	80
Active Pattern	Pattern 1
Coordination Type	Time of Day Pattern Isolated
Actuation Type	Fully actuated
Offset [s]	0.0
Offset Reference	Lead Green - Beginning of First Green
Permissive Mode	SingleBand
Lost time [s]	12.00

**Phasing & Timing (Basic)**

Control Type	Protecte	Permiss	Permiss	Protecte	Permiss	Permiss	Protecte	Permiss	Permiss	Protecte	Permiss	Permiss
Signal Group	3	8	0	7	4	0	5	2	2	1	6	0
Auxiliary Signal Groups												
Maximum Green [s]	20	40	0	5	40	0	4	30	30	5	10	0
Amber [s]	3.5	4.7	0.0	3.5	4.7	0.0	3.5	3.5	3.5	3.5	3.5	0.0
All red [s]	1.0	1.0	0.0	1.0	1.0	0.0	1.0	1.0	1.0	1.0	1.0	0.0
Walk [s]	0	0	0	0	4	0	0	0	0	0	5	0
Pedestrian Clearance [s]	0	0	0	0	28	0	0	0	0	0	10	0
Delayed Vehicle Green [s]	0.0	0.0	0.0	0.0	0.0	0.0	0.0	0.0	0.0	0.0	0.0	0.0
Rest In Walk		No			No			No			No	
I1, Start-Up Lost Time [s]	2.0	2.0	0.0	2.0	2.0	0.0	2.0	2.0	2.0	2.0	2.0	0.0
I2, Clearance Lost Time [s]	2.5	3.7	0.0	2.5	3.7	0.0	2.5	2.5	2.5	2.5	2.5	0.0
Detector Location [ft]	0.0	0.0	0.0	0.0	0.0	0.0	0.0	0.0	0.0	0.0	0.0	0.0
Detector Length [ft]	0.0	0.0	0.0	0.0	0.0	0.0	20.0	20.0	20.0	20.0	20.0	0.0
I, Upstream Filtering Factor	1.00	1.00	1.00	1.00	1.00	1.00	1.00	1.00	1.00	1.00	1.00	1.00

**Phasing & Timing: Pattern 1**

Split [s]	15	41	0	12	38	0	10	17	17	10	17	0
Lead / Lag	Lead	-	-	Lead	-	-	Lead	-	-	Lead	-	-
Minimum Green [s]	10	10	0	5	10	0	5	10	10	5	10	0
Vehicle Extension [s]	2.0	5.0	0.0	3.0	5.0	0.0	3.0	2.0	2.0	3.0	3.0	0.0
Minimum Recall	No	Yes		No	Yes		No	No		No	No	
Maximum Recall	No	No		No	No		No	No		No	No	
Pedestrian Recall	No	No		No	No		No	No		No	No	

**Exclusive Pedestrian Phase**

Pedestrian Signal Group	0
Pedestrian Walk [s]	0
Pedestrian Clearance [s]	0



**Lane Group Calculations**

Lane Group	L	C	R	L	C	R	L	C	R	L	C	R
C, Cycle Length [s]	86	86	86	86	86	86	86	86	86	86	86	86
L, Total Lost Time per Cycle [s]	4.50	5.70	5.70	4.50	5.70	5.70	4.50	4.50	4.50	4.50	4.50	4.50
l1_p, Permitted Start-Up Lost Time [s]	0.00	0.00	0.00	0.00	0.00	0.00	0.00	0.00	0.00	0.00	0.00	0.00
l2, Clearance Lost Time [s]	2.50	3.70	3.70	2.50	3.70	3.70	2.50	2.50	2.50	2.50	2.50	2.50
g_i, Effective Green Time [s]	10	45	45	5	40	40	4	11	11	5	12	12
g / C, Green / Cycle	0.12	0.53	0.53	0.06	0.47	0.47	0.05	0.13	0.13	0.06	0.14	0.14
(v / s)_i Volume / Saturation Flow Rate	0.09	0.22	0.10	0.06	0.33	0.07	0.02	0.10	0.10	0.10	0.00	0.07
s, saturation flow rate [veh/h]	3486	6868	1589	1781	6830	1602	3514	1600	1598	3459	1870	1589
c, Capacity [veh/h]	417	3628	840	104	3188	748	163	210	209	202	268	227
d1, Uniform Delay [s]	36.65	12.17	10.63	40.35	18.25	13.12	39.71	36.07	36.07	40.35	31.58	33.92
k, delay calibration	0.04	0.23	0.23	0.28	0.23	0.23	0.11	0.04	0.04	0.15	0.11	0.11
l, Upstream Filtering Factor	1.00	1.00	1.00	1.00	1.00	1.00	1.00	1.00	1.00	1.00	1.00	1.00
d2, Incremental Delay [s]	1.25	0.16	0.24	91.83	0.64	0.20	1.62	2.49	2.49	301.33	0.04	1.74
d3, Initial Queue Delay [s]	0.00	0.00	0.00	0.00	0.00	0.00	0.00	0.00	0.00	0.00	0.00	0.00
Rp, platoon ratio	1.00	1.00	1.00	1.00	1.00	1.00	1.00	1.00	1.00	1.00	1.00	1.00
PF, progression factor	1.00	1.00	1.00	1.00	1.00	1.00	1.00	1.00	1.00	1.00	1.00	1.00

**Lane Group Results**

X, volume / capacity	0.79	0.41	0.19	1.09	0.71	0.15	0.41	0.79	0.79	1.66	0.03	0.51
d, Delay for Lane Group [s/veh]	37.90	12.33	10.87	132.18	18.89	13.33	41.33	38.56	38.56	341.67	31.62	35.65
Lane Group LOS	D	B	B	F	B	B	D	D	D	F	C	D
Critical Lane Group	Yes	No	No	No	Yes	No	No	No	Yes	Yes	No	No
50th-Percentile Queue Length [veh/ln]	3.22	3.67	1.45	4.75	8.08	1.20	0.71	3.46	3.46	10.54	0.13	2.28
50th-Percentile Queue Length [ft/ln]	80.44	91.67	36.13	118.82	201.89	29.94	17.74	86.49	86.45	263.39	3.15	56.98
95th-Percentile Queue Length [veh/ln]	5.79	6.60	2.60	8.53	12.74	2.16	1.28	6.23	6.22	17.89	0.23	4.10
95th-Percentile Queue Length [ft/ln]	144.79	165.01	65.03	213.25	318.40	53.89	31.94	155.69	155.61	447.37	5.66	102.56





**Movement, Approach, & Intersection Results**

d_M, Delay for Movement [s/veh]	37.90	12.33	10.87	132.18	18.89	13.33	41.33	38.56	38.56	341.67	31.62	35.65
Movement LOS	D	B	B	F	B	B	D	D	D	F	C	D
d_A, Approach Delay [s/veh]	16.45			23.76			39.02			259.74		
Approach LOS	B			C			D			F		
d_I, Intersection Delay [s/veh]	42.38											
Intersection LOS	D											
Intersection V/C	0.728											

**Emissions**

Vehicle Miles Traveled [mph]	49.90	226.09	24.80	15.18	305.01	15.45	4.05	10.13	10.12	20.45	0.43	7.04
Stops [stops/h]	270.67	616.92	60.78	199.91	1358.61	50.37	59.70	145.52	145.44	886.25	5.29	95.86
Fuel consumption [US gal/h]	7.61	19.15	1.97	5.55	33.00	1.36	0.97	2.31	2.31	28.96	0.09	1.65
CO [g/h]	531.62	1338.53	137.45	387.70	2306.96	95.06	67.53	161.37	161.29	2024.08	6.43	115.61
NOx [g/h]	103.43	260.43	26.74	75.43	448.85	18.49	13.14	31.40	31.38	393.81	1.25	22.49
VOC [g/h]	123.21	310.22	31.85	89.85	534.66	22.03	15.65	37.40	37.38	469.10	1.49	26.79

**Other Modes**

g_Walk,mi, Effective Walk Time [s]	0.0			0.0			8.0			35.3		
M_corner, Corner Circulation Area [ft <sup>2</sup> /ped]	0.00			0.00			0.00			0.00		
M_CW, Crosswalk Circulation Area [ft <sup>2</sup> /ped]	0.00			0.00			0.00			0.00		
d_p, Pedestrian Delay [s]	0.00			0.00			35.17			14.78		
I_p,int, Pedestrian LOS Score for Intersectio	0.000			0.000			2.568			2.409		
Crosswalk LOS	F			F			B			B		
s_b, Saturation Flow Rate of the bicycle lane	2000			2000			2000			2000		
c_b, Capacity of the bicycle lane [bicycles/h]	825			755			292			292		
d_b, Bicycle Delay [s]	14.78			16.59			31.21			31.21		
I_b,int, Bicycle LOS Score for Intersection	2.375			2.590			2.213			2.312		
Bicycle LOS	B			B			B			B		

**Sequence**

Ring 1	1	2	3	4	-	-	-	-	-	-	-	-	-	-	-
Ring 2	5	6	7	8	-	-	-	-	-	-	-	-	-	-	-
Ring 3	-	-	-	-	-	-	-	-	-	-	-	-	-	-	-
Ring 4	-	-	-	-	-	-	-	-	-	-	-	-	-	-	-



**Intersection Level Of Service Report**  
**Intersection 11: Fallon Road & I-580 WB Ramps**

Control Type:	Signalized	Delay (sec / veh):	113.4
Analysis Method:	HCM 7th Edition	Level Of Service:	F
Analysis Period:	15 minutes	Volume to Capacity (v/c):	1.196

**Intersection Setup**

Name	Fallon Road			Fallon Road			I-580 WB On-Ramp			I-580 WB Off-Ramp		
Approach	Northbound			Southbound			Eastbound			Westbound		
Lane Configuration	↑			↑↑↑						↑↑↑		
Turning Movement	Left	Thru	Right	Left	Thru	Right	Left	Thru	Right	Left	Thru	Right
Lane Width [ft]	12.00	12.00	12.00	12.00	12.00	12.00	12.00	12.00	12.00	12.00	12.00	12.00
No. of Lanes in Entry Pocket	0	0	0	0	0	1	0	0	0	1	0	1
Entry Pocket Length [ft]	100.00	100.00	100.00	100.00	100.00	225.00	100.00	100.00	100.00	170.00	100.00	130.00
No. of Lanes in Exit Pocket	0	0	1	0	0	0	0	0	1	0	0	0
Exit Pocket Length [ft]	0.00	0.00	400.00	0.00	0.00	0.00	0.00	0.00	400.00	0.00	0.00	0.00
Speed [mph]	45.00			40.00			30.00			35.00		
Grade [%]	0.00			0.00			0.00			0.00		
Curb Present	No			No						No		
Crosswalk	No			No			No			No		



**Volumes**

Name	Fallon Road			Fallon Road			I-580 WB On-Ramp			I-580 WB Off-Ramp		
Base Volume Input [veh/h]	0	1259	0	0	1709	1329	0	0	0	349	1	639
Base Volume Adjustment Factor	1.0000	1.0000	1.0000	1.0000	1.0000	1.0000	1.0000	1.0000	1.0000	1.0000	1.0000	1.0000
Heavy Vehicles Percentage [%]	2.00	0.10	2.00	2.00	0.60	1.00	2.00	2.00	2.00	0.80	0.00	1.50
Proportion of CAVs [%]	0.00											
Growth Factor	1.0000	1.0000	1.0000	1.0000	1.0000	1.0000	1.0000	1.0000	1.0000	1.0000	1.0000	1.0000
In-Process Volume [veh/h]	0	0	0	0	0	0	0	0	0	0	0	0
Site-Generated Trips [veh/h]	0	0	0	0	0	0	0	0	0	0	0	0
Diverted Trips [veh/h]	0	0	0	0	0	0	0	0	0	0	0	0
Pass-by Trips [veh/h]	0	0	0	0	0	0	0	0	0	0	0	0
Existing Site Adjustment Volume [veh/h]	0	0	0	0	0	0	0	0	0	0	0	0
Other Volume [veh/h]	0	0	0	0	0	0	0	0	0	0	0	0
Right Turn on Red Volume [veh/h]	0	0	0	0	0	0	0	0	0	0	0	0
Total Hourly Volume [veh/h]	0	1259	0	0	1709	1329	0	0	0	349	1	639
Peak Hour Factor	1.0000	0.9500	1.0000	1.0000	0.9500	0.9500	1.0000	1.0000	1.0000	0.9500	0.9500	0.9500
Other Adjustment Factor	1.0000	1.0000	1.0000	1.0000	1.0000	1.0000	1.0000	1.0000	1.0000	1.0000	1.0000	1.0000
Total 15-Minute Volume [veh/h]	0	331	0	0	450	350	0	0	0	92	0	168
Total Analysis Volume [veh/h]	0	1325	0	0	1799	1399	0	0	0	367	1	673
Presence of On-Street Parking	No		No	No		No				No		No
On-Street Parking Maneuver Rate [/h]	0	0	0	0	0	0	0	0	0	0	0	0
Local Bus Stopping Rate [/h]	0	0	0	0	0	0	0	0	0	0	0	0
v_do, Outbound Pedestrian Volume crossing	0			0			0			0		
v_di, Inbound Pedestrian Volume crossing m	0			0			0			0		
v_co, Outbound Pedestrian Volume crossing	0			0			0			0		
v_ci, Inbound Pedestrian Volume crossing mi	0			0			0			0		
v_ab, Corner Pedestrian Volume [ped/h]	0			0			0			0		
Bicycle Volume [bicycles/h]	0			0			0			0		



**Intersection Settings**

Located in CBD	No
Signal Coordination Group	-
Cycle Length [s]	90
Active Pattern	Free Running (No Pattern)
Coordination Type	<i>Free Running</i>
Actuation Type	<i>Fully actuated</i>
Offset [s]	0.0
Offset Reference	Lead Green - Beginning of First Green
Permissive Mode	SingleBand
Lost time [s]	9.00

**Phasing & Timing (Basic)**

Control Type	Permiss	Permiss	Permiss	Permiss	Permiss	Permiss	Permiss	Permiss	Permiss	Permiss	Permiss	Overlap
Signal Group	0	2	0	0	6	0	0	0	0	0	8	1
Auxiliary Signal Groups												1,8
Maximum Green [s]	0	35	0	0	35	0	0	0	0	0	20	15
Amber [s]	0.0	4.8	0.0	0.0	4.8	0.0	0.0	0.0	0.0	0.0	3.7	3.7
All red [s]	0.0	0.5	0.0	0.0	0.5	0.0	0.0	0.0	0.0	0.0	0.5	0.5
Walk [s]	0	0	0	0	0	0	0	0	0	0	0	0
Pedestrian Clearance [s]	0	0	0	0	0	0	0	0	0	0	0	0
Delayed Vehicle Green [s]	0.0	0.0	0.0	0.0	0.0	0.0	0.0	0.0	0.0	0.0	0.0	0.0
Rest In Walk		No			No						No	
I1, Start-Up Lost Time [s]	0.0	2.0	0.0	0.0	2.0	0.0	0.0	0.0	0.0	0.0	2.0	2.0
I2, Clearance Lost Time [s]	0.0	3.3	0.0	0.0	3.3	0.0	0.0	0.0	0.0	0.0	2.2	2.2
Detector Location [ft]	0.0	0.0	0.0	0.0	0.0	0.0	0.0	0.0	0.0	0.0	0.0	0.0
Detector Length [ft]	0.0	20.0	0.0	0.0	20.0	0.0	0.0	0.0	0.0	0.0	20.0	20.0
I, Upstream Filtering Factor	1.00	1.00	1.00	1.00	1.00	1.00	1.00	1.00	1.00	1.00	1.00	1.00

**Phasing & Timing: Free Running (No Pattern)**

Split [s]	0	0	0	0	0	0	0	0	0	0	0	0
Lead / Lag	-	-	-	-	-	-	-	-	-	-	-	-
Minimum Green [s]	0	10	0	0	10	0	0	0	0	0	5	4
Vehicle Extension [s]	0.0	0.0	0.0	0.0	0.0	0.0	0.0	0.0	0.0	0.0	0.0	0.0
Minimum Recall		Yes			Yes						No	No
Maximum Recall		No			No						No	No
Pedestrian Recall		No			No						No	No

**Exclusive Pedestrian Phase**

Pedestrian Signal Group	0
Pedestrian Walk [s]	0
Pedestrian Clearance [s]	0



**Lane Group Calculations**

Lane Group	C	C	R		L	C	R
C, Cycle Length [s]	80	80	80		80	80	80
L, Total Lost Time per Cycle [s]	5.30	5.30	5.30		4.20	4.20	4.20
l1_p, Permitted Start-Up Lost Time [s]	0.00	0.00	0.00		0.00	0.00	0.00
l2, Clearance Lost Time [s]	3.30	3.30	3.30		2.20	2.20	0.00
g_i, Effective Green Time [s]	35	54	54		16	16	35
g / C, Green / Cycle	0.44	0.68	0.68		0.20	0.20	0.44
(v / s)_i Volume / Saturation Flow Rate	0.70	0.50	0.87		0.10	0.10	0.24
s, saturation flow rate [veh/h]	1898	3600	1602		1798	1810	2825
c, Capacity [veh/h]	834	2450	1090		360	363	1247
d1, Uniform Delay [s]	22.33	8.13	12.73		28.36	28.36	16.32
k, delay calibration	0.50	0.06	0.50		0.04	0.04	0.09
l, Upstream Filtering Factor	1.00	1.00	1.00		1.00	1.00	1.00
d2, Incremental Delay [s]	270.48	0.24	134.55		0.41	0.41	0.30
d3, Initial Queue Delay [s]	0.00	0.00	0.00		0.00	0.00	0.00
Rp, platoon ratio	1.00	1.00	1.00		1.00	1.00	1.00
PF, progression factor	1.00	1.00	1.00		1.00	1.00	1.00

**Lane Group Results**

X, volume / capacity	1.59	0.73	1.28		0.51	0.51	0.54
d, Delay for Lane Group [s/veh]	292.81	8.37	147.28		28.78	28.77	16.61
Lane Group LOS	F	A	F		C	C	B
Critical Lane Group	No	No	Yes		No	No	Yes
50th-Percentile Queue Length [veh/ln]	75.82	6.78	53.47		3.02	3.04	4.14
50th-Percentile Queue Length [ft/ln]	1895.54	169.61	1336.71		75.50	75.98	103.44
95th-Percentile Queue Length [veh/ln]	117.12	11.06	79.22		5.44	5.47	7.45
95th-Percentile Queue Length [ft/ln]	2927.94	276.40	1980.53		135.91	136.76	186.19

**Movement, Approach, & Intersection Results**

d_M, Delay for Movement [s/veh]	0.00	292.81	0.00	0.00	8.37	147.28	0.00	0.00	0.00	28.78	28.77	16.61
Movement LOS		F			A	F				C	C	B
d_A, Approach Delay [s/veh]	292.81		69.14			0.00			20.91			
Approach LOS	F		E			A			C			
d_I, Intersection Delay [s/veh]	113.38											
Intersection LOS	F											
Intersection V/C	1.196											

**Emissions**

Vehicle Miles Traveled [mph]	138.09	273.71	212.85		26.61	26.78	97.63
Stops [stops/h]	3427.34	613.35	2416.92		136.52	137.37	374.07
Fuel consumption [US gal/h]	126.29	18.89	73.29		3.12	3.13	8.81
CO [g/h]	8827.38	1320.60	5123.03		217.74	219.11	615.83
NOx [g/h]	1717.49	256.94	996.76		42.36	42.63	119.82
VOC [g/h]	2045.83	306.06	1187.31		50.46	50.78	142.73

**Other Modes**

g_Walk,mi, Effective Walk Time [s]	0.0	0.0	0.0	0.0
M_corner, Corner Circulation Area [ft <sup>2</sup> /ped]	0.00	0.00	0.00	0.00
M_CW, Crosswalk Circulation Area [ft <sup>2</sup> /ped]	0.00	0.00	0.00	0.00
d_p, Pedestrian Delay [s]	0.00	0.00	0.00	0.00
I_p,int, Pedestrian LOS Score for Intersectio	0.000	0.000	0.000	0.000
Crosswalk LOS	F	F	F	F
s_b, Saturation Flow Rate of the bicycle lane	2000	2000	2000	2000
c_b, Capacity of the bicycle lane [bicycles/h]	879	879	0	502
d_b, Bicycle Delay [s]	12.51	12.51	39.82	22.33
I_b,int, Bicycle LOS Score for Intersection	3.746	4.198	4.132	3.277
Bicycle LOS	D	D	D	C

**Sequence**

Ring 1	1	2	-	-	-	-	-	-	-	-	-	-	-	-	-
Ring 2	-	6	-	8	-	-	-	-	-	-	-	-	-	-	-
Ring 3	-	-	-	-	-	-	-	-	-	-	-	-	-	-	-
Ring 4	-	-	-	-	-	-	-	-	-	-	-	-	-	-	-



**Intersection Level Of Service Report**  
**Intersection 12: El Charro Road & I-580 EB Ramps**

Control Type:	Signalized	Delay (sec / veh):	8.5
Analysis Method:	HCM 7th Edition	Level Of Service:	A
Analysis Period:	15 minutes	Volume to Capacity (v/c):	0.831

**Intersection Setup**

Name	El Charro Road			Fallon Road			I-580 EB Off-Ramp			I-580 EB On-Ramp		
Approach	Northbound			Southbound			Eastbound			Westbound		
Lane Configuration	↑↑			↑↑			↵↵↵↵					
Turning Movement	Left	Thru	Right	Left	Thru	Right	Left	Thru	Right	Left	Thru	Right
Lane Width [ft]	12.00	12.00	12.00	12.00	12.00	12.00	12.00	12.00	12.00	12.00	12.00	12.00
No. of Lanes in Entry Pocket	0	0	0	1	0	0	1	0	1	0	0	0
Entry Pocket Length [ft]	100.00	100.00	100.00	135.00	100.00	100.00	350.00	100.00	350.00	100.00	100.00	100.00
No. of Lanes in Exit Pocket	0	0	0	0	0	1	0	0	0	0	0	0
Exit Pocket Length [ft]	0.00	0.00	0.00	0.00	0.00	100.00	0.00	0.00	0.00	0.00	0.00	0.00
Speed [mph]	30.00			40.00			35.00			30.00		
Grade [%]	0.00			0.00			0.00			0.00		
Curb Present	No			No			No					
Crosswalk	No			No			No			Yes		



**Volumes**

Name	El Charro Road			Fallon Road			I-580 EB Off-Ramp			I-580 EB On-Ramp		
Base Volume Input [veh/h]	0	1253	0	0	1564	0	470	0	328	0	0	0
Base Volume Adjustment Factor	1.0000	1.0000	1.0000	1.0000	1.0000	1.0000	1.0000	1.0000	1.0000	1.0000	1.0000	1.0000
Heavy Vehicles Percentage [%]	2.00	0.80	2.00	2.00	0.40	2.00	0.30	2.00	1.80	2.00	2.00	2.00
Proportion of CAVs [%]	0.00											
Growth Factor	1.0000	1.0000	1.0000	1.0000	1.0000	1.0000	1.0000	1.0000	1.0000	1.0000	1.0000	1.0000
In-Process Volume [veh/h]	0	0	0	0	0	0	0	0	0	0	0	0
Site-Generated Trips [veh/h]	0	0	0	0	0	0	0	0	0	0	0	0
Diverted Trips [veh/h]	0	0	0	0	0	0	0	0	0	0	0	0
Pass-by Trips [veh/h]	0	0	0	0	0	0	0	0	0	0	0	0
Existing Site Adjustment Volume [veh/h]	0	0	0	0	0	0	0	0	0	0	0	0
Other Volume [veh/h]	0	0	0	0	0	0	0	0	0	0	0	0
Right Turn on Red Volume [veh/h]	0	0	0	0	0	0	0	0	0	0	0	0
Total Hourly Volume [veh/h]	0	1253	0	0	1564	0	470	0	328	0	0	0
Peak Hour Factor	1.0000	0.9600	1.0000	1.0000	0.9600	1.0000	0.9600	1.0000	0.9600	1.0000	1.0000	1.0000
Other Adjustment Factor	1.0000	1.0000	1.0000	1.0000	1.0000	1.0000	1.0000	1.0000	1.0000	1.0000	1.0000	1.0000
Total 15-Minute Volume [veh/h]	0	326	0	0	407	0	122	0	85	0	0	0
Total Analysis Volume [veh/h]	0	1305	0	0	1629	0	490	0	342	0	0	0
Presence of On-Street Parking	No		No	No		No	No		No			
On-Street Parking Maneuver Rate [/h]	0	0	0	0	0	0	0	0	0	0	0	0
Local Bus Stopping Rate [/h]	0	0	0	0	0	0	0	0	0	0	0	0
v_do, Outbound Pedestrian Volume crossing	0			0			0			0		
v_di, Inbound Pedestrian Volume crossing m	0			0			0			0		
v_co, Outbound Pedestrian Volume crossing	0			0			0			0		
v_ci, Inbound Pedestrian Volume crossing mi	0			0			0			0		
v_ab, Corner Pedestrian Volume [ped/h]	0			0			0			0		
Bicycle Volume [bicycles/h]	0			0			0			0		





**Intersection Settings**

Located in CBD	No
Signal Coordination Group	-
Cycle Length [s]	90
Active Pattern	Free Running (No Pattern)
Coordination Type	<i>Free Running</i>
Actuation Type	<i>Fully actuated</i>
Offset [s]	0.0
Offset Reference	Lead Green - Beginning of First Green
Permissive Mode	SingleBand
Lost time [s]	9.00

**Phasing & Timing (Basic)**

Control Type	Permiss	Permiss	Permiss	Permiss	Permiss	Permiss	Permiss	Permiss	Permiss	Permiss	Permiss	Permiss
Signal Group	0	2	0	0	6	0	4	0	0	0	0	0
Auxiliary Signal Groups												
Maximum Green [s]	0	40	0	0	40	0	26	0	0	0	0	0
Amber [s]	0.0	4.8	0.0	0.0	4.8	0.0	3.7	0.0	0.0	0.0	0.0	0.0
All red [s]	0.0	1.0	0.0	0.0	1.0	0.0	0.5	0.0	0.0	0.0	0.0	0.0
Walk [s]	0	0	0	0	0	0	0	0	0	0	0	0
Pedestrian Clearance [s]	0	0	0	0	0	0	0	0	0	0	0	0
Delayed Vehicle Green [s]	0.0	0.0	0.0	0.0	0.0	0.0	0.0	0.0	0.0	0.0	0.0	0.0
Rest In Walk		No			No		No					
I1, Start-Up Lost Time [s]	0.0	2.0	0.0	0.0	2.0	0.0	2.0	0.0	0.0	0.0	0.0	0.0
I2, Clearance Lost Time [s]	0.0	3.3	0.0	0.0	3.3	0.0	2.7	0.0	0.0	0.0	0.0	0.0
Detector Location [ft]	0.0	0.0	0.0	0.0	0.0	0.0	0.0	0.0	0.0	0.0	0.0	0.0
Detector Length [ft]	0.0	0.0	0.0	0.0	0.0	0.0	0.0	0.0	0.0	0.0	0.0	0.0
I, Upstream Filtering Factor	1.00	1.00	1.00	1.00	1.00	1.00	1.00	1.00	1.00	1.00	1.00	1.00

**Phasing & Timing: Free Running (No Pattern)**

Split [s]	0	0	0	0	0	0	0	0	0	0	0	0
Lead / Lag	-	-	-	-	-	-	Lead	-	-	-	-	-
Minimum Green [s]	0	10	0	0	10	0	4	0	0	0	0	0
Vehicle Extension [s]	0.0	0.0	0.0	0.0	0.0	0.0	0.0	0.0	0.0	0.0	0.0	0.0
Minimum Recall		Yes			Yes		No					
Maximum Recall		No			No		No					
Pedestrian Recall		No			No		No					

**Exclusive Pedestrian Phase**

Pedestrian Signal Group	0
Pedestrian Walk [s]	0
Pedestrian Clearance [s]	0



**Lane Group Calculations**

Lane Group	C	C	L	R	
C, Cycle Length [s]	31	31	31	31	
L, Total Lost Time per Cycle [s]	5.30	5.30	4.70	4.70	
l1_p, Permitted Start-Up Lost Time [s]	0.00	0.00	0.00	0.00	
l2, Clearance Lost Time [s]	3.30	3.30	2.70	2.70	
g_i, Effective Green Time [s]	16	16	6	6	
g / C, Green / Cycle	0.50	0.50	0.18	0.18	
(v / s)_i Volume / Saturation Flow Rate	0.36	0.45	0.14	0.12	
s, saturation flow rate [veh/h]	3595	3606	3506	2818	
c, Capacity [veh/h]	1792	1798	641	516	
d1, Uniform Delay [s]	6.20	7.20	12.18	11.93	
k, delay calibration	0.04	0.04	0.04	0.04	
l, Upstream Filtering Factor	1.00	1.00	1.00	1.00	
d2, Incremental Delay [s]	0.21	0.76	0.72	0.55	
d3, Initial Queue Delay [s]	0.00	0.00	0.00	0.00	
Rp, platoon ratio	1.00	1.00	1.00	1.00	
PF, progression factor	1.00	1.00	1.00	1.00	

**Lane Group Results**

X, volume / capacity	0.73	0.91	0.76	0.66	
d, Delay for Lane Group [s/veh]	6.41	7.96	12.90	12.47	
Lane Group LOS	A	A	B	B	
Critical Lane Group	No	Yes	Yes	No	
50th-Percentile Queue Length [veh/ln]	1.57	1.71	1.20	0.82	
50th-Percentile Queue Length [ft/ln]	39.18	42.78	30.01	20.39	
95th-Percentile Queue Length [veh/ln]	2.82	3.08	2.16	1.47	
95th-Percentile Queue Length [ft/ln]	70.53	77.01	54.02	36.71	

**Movement, Approach, & Intersection Results**

d_M, Delay for Movement [s/veh]	0.00	6.41	0.00	0.00	7.96	0.00	12.90	0.00	12.47	0.00	0.00	0.00
Movement LOS		A			A		B		B			
d_A, Approach Delay [s/veh]	6.41		7.96			12.73			0.00			
Approach LOS	A		A			B			A			
d_I, Intersection Delay [s/veh]	8.48											
Intersection LOS	A											
Intersection V/C	0.831											

**Emissions**

Vehicle Miles Traveled [mph]	224.66	159.99	56.94	39.74
Stops [stops/h]	360.96	394.12	276.48	187.85
Fuel consumption [US gal/h]	12.95	12.24	5.54	3.80
CO [g/h]	904.91	855.67	386.99	265.33
NOx [g/h]	176.06	166.48	75.29	51.62
VOC [g/h]	209.72	198.31	89.69	61.49

**Other Modes**

g_Walk,mi, Effective Walk Time [s]	0.0	0.0	0.0	-5.8
M_corner, Corner Circulation Area [ft <sup>2</sup> /ped]	0.00	0.00	0.00	0.00
M_CW, Crosswalk Circulation Area [ft <sup>2</sup> /ped]	0.00	0.00	0.00	0.00
d_p, Pedestrian Delay [s]	0.00	0.00	0.00	21.97
I_p,int, Pedestrian LOS Score for Intersectio	0.000	0.000	0.000	1.696
Crosswalk LOS	F	F	F	A
s_b, Saturation Flow Rate of the bicycle lane	2000	2000	2000	2000
c_b, Capacity of the bicycle lane [bicycles/h]	2559	2559	1663	0
d_b, Bicycle Delay [s]	1.22	1.22	0.44	15.63
I_b,int, Bicycle LOS Score for Intersection	2.636	2.904	1.560	4.132
Bicycle LOS	B	C	A	D

**Sequence**

Ring 1	-	2	-	4	-	-	-	-	-	-	-	-	-	-	-
Ring 2	-	6	-	-	-	-	-	-	-	-	-	-	-	-	-
Ring 3	-	-	-	-	-	-	-	-	-	-	-	-	-	-	-
Ring 4	-	-	-	-	-	-	-	-	-	-	-	-	-	-	-



**Intersection Level Of Service Report**  
**Intersection 13: El Charro Road & Jack London Boulevard**

Control Type:	Signalized	Delay (sec / veh):	38.6
Analysis Method:	HCM 7th Edition	Level Of Service:	D
Analysis Period:	15 minutes	Volume to Capacity (v/c):	0.798

**Intersection Setup**

Name	El Charro Road			El Charro Road			Stoneridge Drive			Jack London Boulevard		
Approach	Northbound			Southbound			Eastbound			Westbound		
Lane Configuration	T T T			R T T			R T T			T T T		
Turning Movement	Left	Thru	Right	Left	Thru	Right	Left	Thru	Right	Left	Thru	Right
Lane Width [ft]	12.00	12.00	12.00	12.00	12.00	12.00	12.00	12.00	12.00	12.00	12.00	12.00
No. of Lanes in Entry Pocket	1	0	2	2	0	1	3	0	1	1	0	2
Entry Pocket Length [ft]	125.00	100.00	175.00	650.00	100.00	450.00	450.00	100.00	325.00	400.00	100.00	775.00
No. of Lanes in Exit Pocket	0	0	0	0	0	2	1	0	0	0	0	0
Exit Pocket Length [ft]	0.00	0.00	0.00	0.00	0.00	100.00	450.00	0.00	0.00	0.00	0.00	0.00
Speed [mph]	30.00			30.00			30.00			30.00		
Grade [%]	0.00			0.00			0.00			0.00		
Curb Present	Yes			Yes			Yes			Yes		
Crosswalk	Yes			No			Yes			Yes		



**Volumes**

Name	El Charro Road			El Charro Road			Stoneridge Drive			Jack London Boulevard		
Base Volume Input [veh/h]	106	483	292	1061	429	427	790	430	219	112	168	650
Base Volume Adjustment Factor	1.0000	1.0000	1.0000	1.0000	1.0000	1.0000	1.0000	1.0000	1.0000	1.0000	1.0000	1.0000
Heavy Vehicles Percentage [%]	0.00	20.00	0.00	0.30	44.40	0.80	0.50	0.50	0.00	0.00	1.80	0.60
Proportion of CAVs [%]	0.00											
Growth Factor	1.0000	1.0000	1.0000	1.0000	1.0000	1.0000	1.0000	1.0000	1.0000	1.0000	1.0000	1.0000
In-Process Volume [veh/h]	0	0	0	0	0	0	0	0	0	0	0	0
Site-Generated Trips [veh/h]	0	0	0	0	0	0	0	0	0	0	0	0
Diverted Trips [veh/h]	0	0	0	0	0	0	0	0	0	0	0	0
Pass-by Trips [veh/h]	0	0	0	0	0	0	0	0	0	0	0	0
Existing Site Adjustment Volume [veh/h]	0	0	0	0	0	0	0	0	0	0	0	0
Other Volume [veh/h]	0	0	0	0	0	0	0	0	0	0	0	0
Right Turn on Red Volume [veh/h]	0	0	0	0	0	0	0	0	0	0	0	0
Total Hourly Volume [veh/h]	106	483	292	1061	429	427	790	430	219	112	168	650
Peak Hour Factor	0.9200	0.9200	0.9200	0.9200	0.9200	0.9200	0.9200	0.9200	0.9200	0.9200	0.9200	0.9200
Other Adjustment Factor	1.0000	1.0000	1.0000	1.0000	1.0000	1.0000	1.0000	1.0000	1.0000	1.0000	1.0000	1.0000
Total 15-Minute Volume [veh/h]	29	131	79	288	117	116	215	117	60	30	46	177
Total Analysis Volume [veh/h]	115	525	317	1153	466	464	859	467	238	122	183	707
Presence of On-Street Parking	No		No	No		No	No		No	No		No
On-Street Parking Maneuver Rate [/h]	0	0	0	0	0	0	0	0	0	0	0	0
Local Bus Stopping Rate [/h]	0	0	0	0	0	0	0	0	0	0	0	0
v_do, Outbound Pedestrian Volume crossing	0			0			0			0		
v_di, Inbound Pedestrian Volume crossing m	0			0			0			0		
v_co, Outbound Pedestrian Volume crossing	0			0			0			0		
v_ci, Inbound Pedestrian Volume crossing mi	0			0			0			0		
v_ab, Corner Pedestrian Volume [ped/h]	0			0			0			0		
Bicycle Volume [bicycles/h]	0			0			0			0		



**Intersection Settings**

Located in CBD	No
Signal Coordination Group	-
Cycle Length [s]	90
Active Pattern	Free Running (No Pattern)
Coordination Type	<i>Free Running</i>
Actuation Type	<i>Fully actuated</i>
Offset [s]	0.0
Offset Reference	Lead Green - Beginning of First Green
Permissive Mode	SingleBand
Lost time [s]	12.00

**Phasing & Timing (Basic)**

Control Type	Protecte	Permiss	Permiss	Protecte	Permiss	Permiss	ProtPer	Permiss	Permiss	ProtPer	Permiss	Overlap
Signal Group	7	4	0	3	8	0	1	6	0	5	2	2
Auxiliary Signal Groups												2,3
Maximum Green [s]	5	25	0	35	20	0	4	25	0	7	20	20
Amber [s]	3.0	5.0	0.0	3.0	4.3	0.0	3.0	4.3	0.0	3.0	4.3	4.3
All red [s]	1.0	1.0	0.0	1.0	1.0	0.0	1.0	1.0	0.0	1.0	1.0	1.0
Walk [s]	0	5	0	0	5	0	0	5	0	0	0	0
Pedestrian Clearance [s]	0	28	0	0	28	0	0	30	0	0	0	0
Delayed Vehicle Green [s]	0.0	0.0	0.0	0.0	0.0	0.0	0.0	0.0	0.0	0.0	0.0	0.0
Rest In Walk		No			No			No			No	
I1, Start-Up Lost Time [s]	2.0	2.0	0.0	2.0	2.0	0.0	2.0	2.0	0.0	2.0	2.0	2.0
I2, Clearance Lost Time [s]	2.0	2.0	0.0	2.0	2.0	0.0	2.0	2.0	0.0	2.0	2.0	2.0
Detector Location [ft]	0.0	0.0	0.0	0.0	0.0	0.0	0.0	0.0	0.0	0.0	0.0	0.0
Detector Length [ft]	0.0	0.0	0.0	0.0	0.0	0.0	0.0	0.0	0.0	0.0	0.0	0.0
I, Upstream Filtering Factor	1.00	1.00	1.00	1.00	1.00	1.00	1.00	1.00	1.00	1.00	1.00	1.00

**Phasing & Timing: Free Running (No Pattern)**

Split [s]	0	0	0	0	0	0	0	0	0	0	0	0
Lead / Lag	Lead	-	-	Lead	-	-	Lead	-	-	Lead	-	-
Minimum Green [s]	4	5	0	7	5	0	5	4	0	4	7	7
Vehicle Extension [s]	2.0	2.5	0.0	2.5	2.5	0.0	2.0	3.0	0.0	2.0	3.0	3.0
Minimum Recall	Yes	No		No	No		Yes	Yes		Yes	Yes	Yes
Maximum Recall	No	No		No	No		No	No		No	No	No
Pedestrian Recall	No	No		No	No		No	No		No	No	No

**Exclusive Pedestrian Phase**

Pedestrian Signal Group	0
Pedestrian Walk [s]	0
Pedestrian Clearance [s]	0



**Lane Group Calculations**

Lane Group	L	C	C	L	C	R	L	C	R	L	C	R
C, Cycle Length [s]	104	104	104	104	104	104	104	104	104	104	104	104
L, Total Lost Time per Cycle [s]	4.00	4.00	4.00	4.00	4.00	4.00	4.00	4.00	4.00	4.00	4.00	4.00
l1_p, Permitted Start-Up Lost Time [s]	0.00	0.00	0.00	0.00	0.00	0.00	0.00	0.00	0.00	0.00	0.00	0.00
l2, Clearance Lost Time [s]	2.00	2.00	2.00	2.00	2.00	2.00	0.00	2.00	2.00	0.00	2.00	0.00
g_i, Effective Green Time [s]	5	27	27	28	50	50	37	26	26	37	29	61
g / C, Green / Cycle	0.05	0.26	0.26	0.27	0.48	0.48	0.36	0.25	0.25	0.36	0.28	0.59
(v / s)_i Volume / Saturation Flow Rate	0.06	0.17	0.23	0.22	0.38	0.29	0.36	0.13	0.15	0.12	0.05	0.25
s, saturation flow rate [veh/h]	1810	3046	1360	5259	1234	1605	2393	3603	1615	1004	3566	2845
c, Capacity [veh/h]	87	790	353	1415	593	771	950	911	408	376	996	1670
d1, Uniform Delay [s]	49.54	34.48	37.22	35.60	22.57	19.76	33.84	33.39	34.08	24.83	28.49	11.82
k, delay calibration	0.45	0.08	0.41	0.08	0.50	0.50	0.50	0.11	0.16	0.17	0.11	0.18
l, Upstream Filtering Factor	1.00	1.00	1.00	1.00	1.00	1.00	1.00	1.00	1.00	1.00	1.00	1.00
d2, Incremental Delay [s]	200.54	0.72	24.43	0.89	10.10	3.46	13.56	0.45	1.97	0.76	0.09	0.28
d3, Initial Queue Delay [s]	0.00	0.00	0.00	0.00	0.00	0.00	0.00	0.00	0.00	0.00	0.00	0.00
Rp, platoon ratio	1.00	1.00	1.00	1.00	1.00	1.00	1.00	1.00	1.00	1.00	1.00	1.00
PF, progression factor	1.00	1.00	1.00	1.00	1.00	1.00	1.00	1.00	1.00	1.00	1.00	1.00

**Lane Group Results**

X, volume / capacity	1.32	0.66	0.90	0.81	0.79	0.60	0.90	0.51	0.58	0.32	0.18	0.42
d, Delay for Lane Group [s/veh]	250.07	35.20	61.65	36.49	32.67	23.21	47.40	33.84	36.06	25.59	28.58	12.10
Lane Group LOS	F	D	E	D	C	C	D	C	D	C	C	B
Critical Lane Group	No	No	Yes	Yes	No	No	Yes	No	No	No	No	Yes
50th-Percentile Queue Length [veh/ln]	7.09	5.95	10.05	9.10	10.75	8.66	6.70	5.07	5.44	2.18	1.74	4.33
50th-Percentile Queue Length [ft/ln]	177.27	148.75	251.15	227.39	268.70	216.47	167.45	126.87	136.12	54.58	43.56	108.17
95th-Percentile Queue Length [veh/ln]	12.30	9.95	15.24	14.04	16.12	13.48	10.94	8.77	9.27	3.93	3.14	7.74
95th-Percentile Queue Length [ft/ln]	307.38	248.76	381.10	351.04	403.12	337.11	273.56	219.23	231.79	98.25	78.41	193.45



**Movement, Approach, & Intersection Results**

d_M, Delay for Movement [s/veh]	250.07	35.20	61.65	36.49	32.67	23.21	47.40	33.84	36.06	25.59	28.58	12.10
Movement LOS	F	D	E	D	C	C	D	C	D	C	C	B
d_A, Approach Delay [s/veh]	69.78			32.68			41.62			16.71		
Approach LOS	E			C			D			B		
d_I, Intersection Delay [s/veh]	38.61											
Intersection LOS	D											
Intersection V/C	0.798											

**Emissions**

Vehicle Miles Traveled [mph]	7.30	33.32	20.12	198.49	80.22	79.88	109.66	59.62	30.38	21.20	31.79	122.83
Stops [stops/h]	245.40	411.83	347.67	944.36	371.97	299.66	695.43	351.26	188.43	75.56	120.61	299.49
Fuel consumption [US gal/h]	7.51	7.41	6.73	21.95	8.46	7.14	16.64	7.61	4.04	1.93	3.04	8.45
CO [g/h]	524.77	517.81	470.13	1534.30	591.06	498.80	1163.24	531.98	282.26	134.58	212.46	590.80
NOx [g/h]	102.10	100.75	91.47	298.52	115.00	97.05	226.32	103.50	54.92	26.18	41.34	114.95
VOC [g/h]	121.62	120.01	108.96	355.59	136.98	115.60	269.59	123.29	65.42	31.19	49.24	136.92

**Other Modes**

g_Walk,mi, Effective Walk Time [s]	9.0	0.0	9.0	9.0
M_corner, Corner Circulation Area [ft <sup>2</sup> /ped]	0.00	0.00	0.00	0.00
M_CW, Crosswalk Circulation Area [ft <sup>2</sup> /ped]	0.00	0.00	0.00	0.00
d_p, Pedestrian Delay [s]	43.40	0.00	43.40	43.40
I_p,int, Pedestrian LOS Score for Intersectio	2.703	0.000	3.110	3.093
Crosswalk LOS	B	F	C	C
s_b, Saturation Flow Rate of the bicycle lane	2000	2000	2000	2000
c_b, Capacity of the bicycle lane [bicycles/h]	481	385	481	385
d_b, Bicycle Delay [s]	30.01	33.93	30.01	33.93
I_b,int, Bicycle LOS Score for Intersection	2.086	4.997	2.850	2.395
Bicycle LOS	B	E	C	B

**Sequence**

Ring 1	1	2	3	4	-	-	-	-	-	-	-	-	-	-	-
Ring 2	5	6	7	8	-	-	-	-	-	-	-	-	-	-	-
Ring 3	-	-	-	-	-	-	-	-	-	-	-	-	-	-	-
Ring 4	-	-	-	-	-	-	-	-	-	-	-	-	-	-	-





**Intersection Level Of Service Report**  
**Intersection 14: Central Parkway & Sunset View Drive**

Control Type:	Signalized	Delay (sec / veh):	11.8
Analysis Method:	HCM 7th Edition	Level Of Service:	B
Analysis Period:	15 minutes	Volume to Capacity (v/c):	0.286

**Intersection Setup**

Name	Driveway			Sunset View Drive			Central Parkway			Central Parkway		
Approach	Northbound			Southbound			Eastbound			Westbound		
Lane Configuration	↔			↔			↔↔			↔		
Turning Movement	Left	Thru	Right	Left	Thru	Right	Left	Thru	Right	Left	Thru	Right
Lane Width [ft]	12.00	12.00	12.00	12.00	12.00	12.00	12.00	12.00	12.00	12.00	12.00	12.00
No. of Lanes in Entry Pocket	1	0	0	0	0	1	1	0	1	1	0	0
Entry Pocket Length [ft]	250.00	100.00	100.00	100.00	100.00	85.00	225.00	100.00	800.00	150.00	100.00	100.00
No. of Lanes in Exit Pocket	0	0	0	0	0	0	0	0	0	0	0	0
Exit Pocket Length [ft]	0.00	0.00	0.00	0.00	0.00	0.00	0.00	0.00	0.00	0.00	0.00	0.00
Speed [mph]	30.00			30.00			30.00			30.00		
Grade [%]	0.00			0.00			0.00			0.00		
Curb Present	No			No			No			No		
Crosswalk	Yes			Yes			Yes			Yes		



**Volumes**

Name	Driveway			Sunset View Drive			Central Parkway			Central Parkway		
Base Volume Input [veh/h]	15	1	6	3	1	74	81	192	19	19	101	1
Base Volume Adjustment Factor	1.0000	1.0000	1.0000	1.0000	1.0000	1.0000	1.0000	1.0000	1.0000	1.0000	1.0000	1.0000
Heavy Vehicles Percentage [%]	0.00	0.00	0.00	0.00	0.00	0.00	0.00	0.00	0.00	0.00	0.00	0.00
Proportion of CAVs [%]	0.00											
Growth Factor	1.0000	1.0000	1.0000	1.0000	1.0000	1.0000	1.0000	1.0000	1.0000	1.0000	1.0000	1.0000
In-Process Volume [veh/h]	0	0	0	0	0	0	0	0	0	0	0	0
Site-Generated Trips [veh/h]	0	0	0	0	0	0	0	0	0	0	0	0
Diverted Trips [veh/h]	0	0	0	0	0	0	0	0	0	0	0	0
Pass-by Trips [veh/h]	0	0	0	0	0	0	0	0	0	0	0	0
Existing Site Adjustment Volume [veh/h]	0	0	0	0	0	0	0	0	0	0	0	0
Other Volume [veh/h]	0	0	0	0	0	0	0	0	0	0	0	0
Right Turn on Red Volume [veh/h]	0	0	0	0	0	0	0	0	0	0	0	0
Total Hourly Volume [veh/h]	15	1	6	3	1	74	81	192	19	19	101	1
Peak Hour Factor	0.9200	0.9200	0.9200	0.9200	0.9200	0.9200	0.9200	0.9200	0.9200	0.9200	0.9200	0.9200
Other Adjustment Factor	1.0000	1.0000	1.0000	1.0000	1.0000	1.0000	1.0000	1.0000	1.0000	1.0000	1.0000	1.0000
Total 15-Minute Volume [veh/h]	4	0	2	1	0	20	22	52	5	5	27	0
Total Analysis Volume [veh/h]	16	1	7	3	1	80	88	209	21	21	110	1
Presence of On-Street Parking	No		No	No		No	No		No	No		No
On-Street Parking Maneuver Rate [/h]	0	0	0	0	0	0	0	0	0	0	0	0
Local Bus Stopping Rate [/h]	0	0	0	0	0	0	0	0	0	0	0	0
v_do, Outbound Pedestrian Volume crossing	2			1			1			0		
v_di, Inbound Pedestrian Volume crossing m	1			0			2			1		
v_co, Outbound Pedestrian Volume crossing	0			0			0			0		
v_ci, Inbound Pedestrian Volume crossing mi	0			0			0			0		
v_ab, Corner Pedestrian Volume [ped/h]	0			0			0			0		
Bicycle Volume [bicycles/h]	0			0			1			0		



**Intersection Settings**

Located in CBD	No
Signal Coordination Group	-
Cycle Length [s]	90
Active Pattern	Free Running (No Pattern)
Coordination Type	<i>Free Running</i>
Actuation Type	<i>Fully actuated</i>
Offset [s]	0.0
Offset Reference	Lead Green - Beginning of First Green
Permissive Mode	SingleBand
Lost time [s]	12.00

**Phasing & Timing (Basic)**

Control Type	Protecte	Permiss	Permiss	Protecte	Permiss	Permiss	Protecte	Permiss	Permiss	Protecte	Permiss	Permiss
Signal Group	3	8	0	7	4	0	5	2	0	1	6	0
Auxiliary Signal Groups												
Maximum Green [s]	30	30	0	20	20	0	20	25	0	20	25	0
Amber [s]	3.0	3.0	0.0	3.0	3.0	0.0	3.0	3.6	0.0	3.0	3.6	0.0
All red [s]	1.0	1.0	0.0	1.0	1.0	0.0	1.0	1.0	0.0	1.0	1.0	0.0
Walk [s]	0	4	0	0	4	0	0	4	0	0	4	0
Pedestrian Clearance [s]	0	24	0	0	21	0	0	16	0	0	17	0
Delayed Vehicle Green [s]	0.0	0.0	0.0	0.0	0.0	0.0	0.0	0.0	0.0	0.0	0.0	0.0
Rest In Walk		No			No			No			No	
I1, Start-Up Lost Time [s]	2.0	2.0	0.0	2.0	2.0	0.0	2.0	2.0	0.0	2.0	2.0	0.0
I2, Clearance Lost Time [s]	2.0	2.0	0.0	2.0	2.0	0.0	2.0	2.0	0.0	2.0	2.0	0.0
Detector Location [ft]	0.0	0.0	0.0	0.0	0.0	0.0	0.0	0.0	0.0	0.0	0.0	0.0
Detector Length [ft]	20.0	20.0	0.0	20.0	20.0	0.0	20.0	20.0	0.0	20.0	20.0	0.0
I, Upstream Filtering Factor	1.00	1.00	1.00	1.00	1.00	1.00	1.00	1.00	1.00	1.00	1.00	1.00

**Phasing & Timing: Free Running (No Pattern)**

Split [s]	9	14	0	9	14	0	9	14	0	9	14	0
Lead / Lag	Lead	-	-	Lead	-	-	Lead	-	-	Lead	-	-
Minimum Green [s]	5	10	0	5	10	0	5	10	0	5	10	0
Vehicle Extension [s]	2.0	4.0	0.0	2.0	4.0	0.0	2.0	4.0	0.0	2.0	4.0	0.0
Minimum Recall	No	No		No	No		No	Yes		No	Yes	
Maximum Recall	No	No		No	No		No	No		No	No	
Pedestrian Recall	No	No		No	No		No	No		No	No	

**Exclusive Pedestrian Phase**

Pedestrian Signal Group	0
Pedestrian Walk [s]	0
Pedestrian Clearance [s]	0



**Lane Group Calculations**

Lane Group	L	C	L	C	L	C	R	L	C
C, Cycle Length [s]	32	32	32	32	32	32	32	32	32
L, Total Lost Time per Cycle [s]	4.00	4.00	4.00	4.00	4.00	4.00	4.00	4.00	4.00
l1_p, Permitted Start-Up Lost Time [s]	0.00	0.00	0.00	0.00	0.00	0.00	0.00	0.00	0.00
l2, Clearance Lost Time [s]	2.00	2.00	2.00	2.00	2.00	2.00	2.00	2.00	2.00
g_i, Effective Green Time [s]	1	6	0	5	3	10	10	1	8
g / C, Green / Cycle	0.02	0.18	0.00	0.16	0.09	0.30	0.30	0.03	0.24
(v / s)_i Volume / Saturation Flow Rate	0.01	0.00	0.00	0.05	0.05	0.11	0.01	0.01	0.06
s, saturation flow rate [veh/h]	1810	1646	1810	1618	1810	1900	1573	1810	1897
c, Capacity [veh/h]	41	299	9	266	157	561	464	51	448
d1, Uniform Delay [s]	15.74	10.99	16.19	12.01	14.30	9.11	8.22	15.60	10.11
k, delay calibration	0.04	0.15	0.04	0.15	0.04	0.15	0.15	0.04	0.15
l, Upstream Filtering Factor	1.00	1.00	1.00	1.00	1.00	1.00	1.00	1.00	1.00
d2, Incremental Delay [s]	2.30	0.05	8.17	0.91	1.16	0.59	0.06	1.97	0.41
d3, Initial Queue Delay [s]	0.00	0.00	0.00	0.00	0.00	0.00	0.00	0.00	0.00
Rp, platoon ratio	1.00	1.00	1.00	1.00	1.00	1.00	1.00	1.00	1.00
PF, progression factor	1.00	1.00	1.00	1.00	1.00	1.00	1.00	1.00	1.00

**Lane Group Results**

X, volume / capacity	0.39	0.03	0.34	0.30	0.56	0.37	0.05	0.41	0.25
d, Delay for Lane Group [s/veh]	18.04	11.04	24.36	12.92	15.46	9.70	8.27	17.57	10.52
Lane Group LOS	B	B	C	B	B	A	A	B	B
Critical Lane Group	Yes	No	No	Yes	No	Yes	No	Yes	No
50th-Percentile Queue Length [veh/ln]	0.12	0.04	0.04	0.47	0.55	0.91	0.08	0.15	0.52
50th-Percentile Queue Length [ft/ln]	3.04	1.01	0.96	11.63	13.65	22.66	2.03	3.82	13.05
95th-Percentile Queue Length [veh/ln]	0.22	0.07	0.07	0.84	0.98	1.63	0.15	0.28	0.94
95th-Percentile Queue Length [ft/ln]	5.48	1.82	1.73	20.93	24.56	40.78	3.65	6.88	23.49

**Movement, Approach, & Intersection Results**

d_M, Delay for Movement [s/veh]	18.04	11.04	11.04	24.36	12.92	12.92	15.46	9.70	8.27	17.57	10.52	10.52
Movement LOS	B	B	B	C	B	B	B	A	A	B	B	B
d_A, Approach Delay [s/veh]	15.71			13.33			11.20			11.64		
Approach LOS	B			B			B			B		
d_I, Intersection Delay [s/veh]	11.82											
Intersection LOS	B											
Intersection V/C	0.286											

**Emissions**

Vehicle Miles Traveled [mph]	0.44	0.22	0.11	3.01	20.01	47.51	4.77	4.44	23.46
Stops [stops/h]	13.51	4.49	4.25	51.59	60.55	100.53	9.00	16.96	57.91
Fuel consumption [US gal/h]	0.15	0.05	0.04	0.62	1.43	2.92	0.28	0.35	1.52
CO [g/h]	10.58	3.62	3.00	43.47	100.31	204.38	19.69	24.57	106.49
NOx [g/h]	2.06	0.70	0.58	8.46	19.52	39.76	3.83	4.78	20.72
VOC [g/h]	2.45	0.84	0.70	10.08	23.25	47.37	4.56	5.69	24.68

**Other Modes**

g_Walk,mi, Effective Walk Time [s]	8.0	8.0	8.0	8.0
M_corner, Corner Circulation Area [ft <sup>2</sup> /ped]	0.00	0.00	0.00	0.00
M_CW, Crosswalk Circulation Area [ft <sup>2</sup> /ped]	0.00	0.00	0.00	0.00
d_p, Pedestrian Delay [s]	9.21	9.21	9.21	9.21
I_p,int, Pedestrian LOS Score for Intersectio	1.908	1.943	2.205	2.001
Crosswalk LOS	A	A	B	B
s_b, Saturation Flow Rate of the bicycle lane	2000	2000	2000	2000
c_b, Capacity of the bicycle lane [bicycles/h]	1849	1233	1541	1541
d_b, Bicycle Delay [s]	0.09	2.39	0.86	0.86
I_b,int, Bicycle LOS Score for Intersection	1.599	1.698	2.084	1.777
Bicycle LOS	A	A	B	A

**Sequence**

Ring 1	1	2	3	4	-	-	-	-	-	-	-	-	-	-	-
Ring 2	5	6	7	8	-	-	-	-	-	-	-	-	-	-	-
Ring 3	-	-	-	-	-	-	-	-	-	-	-	-	-	-	-
Ring 4	-	-	-	-	-	-	-	-	-	-	-	-	-	-	-

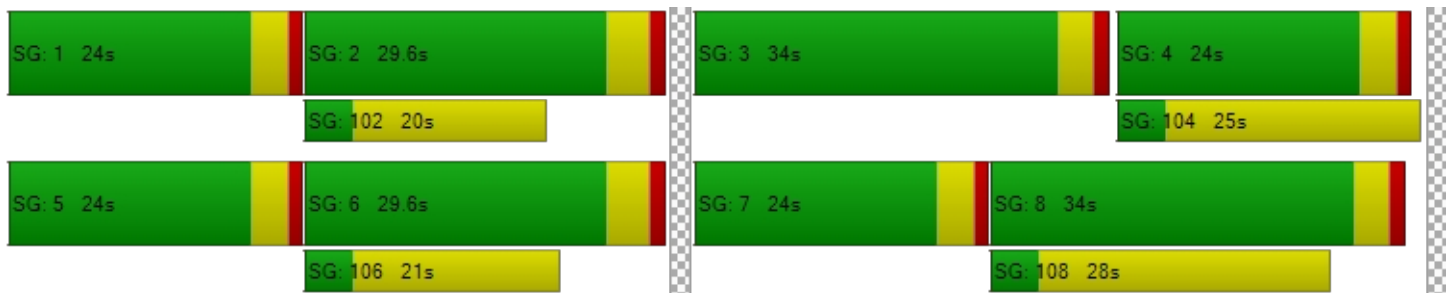

**Intersection Level Of Service Report**

**Intersection 15: Central Parkway & Panorama Drive/Pino Grande Road**

Control Type:	All-way stop	Delay (sec / veh):	8.2
Analysis Method:	HCM 7th Edition	Level Of Service:	A
Analysis Period:	15 minutes	Volume to Capacity (v/c):	0.149

**Intersection Setup**

Name	Pino Grande Road			Panorama Drive			Central Parkway			Central Parkway		
Approach	Northbound			Southbound			Eastbound			Westbound		
Lane Configuration	+			+r			+r			+r		
Turning Movement	Left	Thru	Right	Left	Thru	Right	Left	Thru	Right	Left	Thru	Right
Lane Width [ft]	12.00	12.00	12.00	12.00	12.00	12.00	12.00	12.00	12.00	12.00	12.00	12.00
No. of Lanes in Entry Pocket	0	0	0	0	0	1	1	0	0	1	0	0
Entry Pocket Length [ft]	100.00	100.00	100.00	100.00	100.00	100.00	275.00	100.00	100.00	100.00	100.00	100.00
No. of Lanes in Exit Pocket	0	0	0	0	0	0	0	0	0	0	0	0
Exit Pocket Length [ft]	0.00	0.00	0.00	0.00	0.00	0.00	0.00	0.00	0.00	0.00	0.00	0.00
Speed [mph]	30.00			30.00			30.00			30.00		
Grade [%]	0.00			0.00			0.00			0.00		
Crosswalk	Yes			Yes			Yes			Yes		

**Volumes**

Name	Pino Grande Road			Panorama Drive			Central Parkway			Central Parkway		
Base Volume Input [veh/h]	18	0	2	7	0	71	95	57	47	9	39	27
Base Volume Adjustment Factor	1.0000	1.0000	1.0000	1.0000	1.0000	1.0000	1.0000	1.0000	1.0000	1.0000	1.0000	1.0000
Heavy Vehicles Percentage [%]	0.00	0.00	0.00	0.00	0.00	0.00	0.00	0.00	0.00	0.00	0.00	0.00
Growth Factor	1.0000	1.0000	1.0000	1.0000	1.0000	1.0000	1.0000	1.0000	1.0000	1.0000	1.0000	1.0000
In-Process Volume [veh/h]	0	0	0	0	0	0	0	0	0	0	0	0
Site-Generated Trips [veh/h]	0	0	0	0	0	0	0	0	0	0	0	0
Diverted Trips [veh/h]	0	0	0	0	0	0	0	0	0	0	0	0
Pass-by Trips [veh/h]	0	0	0	0	0	0	0	0	0	0	0	0
Existing Site Adjustment Volume [veh/h]	0	0	0	0	0	0	0	0	0	0	0	0
Other Volume [veh/h]	0	0	0	0	0	0	0	0	0	0	0	0
Total Hourly Volume [veh/h]	18	0	2	7	0	71	95	57	47	9	39	27
Peak Hour Factor	0.9400	0.9400	0.9400	0.9400	0.9400	0.9400	0.9400	0.9400	0.9400	0.9400	0.9400	0.9400
Other Adjustment Factor	1.0000	1.0000	1.0000	1.0000	1.0000	1.0000	1.0000	1.0000	1.0000	1.0000	1.0000	1.0000
Total 15-Minute Volume [veh/h]	5	0	1	2	0	19	25	15	13	2	10	7
Total Analysis Volume [veh/h]	19	0	2	7	0	76	101	61	50	10	41	29
Pedestrian Volume [ped/h]	2			3			2			4		



**Intersection Settings**

**Lanes**

Capacity per Entry Lane [veh/h]	667	632	800	677	799	662	774
Degree of Utilization, x	0.03	0.01	0.10	0.15	0.14	0.02	0.09

**Movement, Approach, & Intersection Results**

95th-Percentile Queue Length [veh]	0.10	0.03	0.31	0.52	0.48	0.05	0.30
95th-Percentile Queue Length [ft]	2.43	0.84	7.85	13.07	12.04	1.15	7.43
Approach Delay [s/veh]	8.57	7.74		8.42		7.86	
Approach LOS	A	A		A		A	
Intersection Delay [s/veh]	8.17						
Intersection LOS	A						



**Intersection Level Of Service Report**  
**Intersection 16: Airway Boulevard & N. Canyons Parkway**

Control Type:	Signalized	Delay (sec / veh):	142.7
Analysis Method:	HCM 7th Edition	Level Of Service:	F
Analysis Period:	15 minutes	Volume to Capacity (v/c):	1.146

**Intersection Setup**

Name	Airway Boulevard			Driveway			N. Canyons Parkway			N Canyons Parkway		
Approach	Northbound			Southbound			Eastbound			Westbound		
Lane Configuration	↔↔↔↔			+			↔↔			↔↔↔↔		
Turning Movement	Left	Thru	Right	Left	Thru	Right	Left	Thru	Right	Left	Thru	Right
Lane Width [ft]	12.00	12.00	12.00	12.00	12.00	12.00	12.00	12.00	12.00	12.00	12.00	12.00
No. of Lanes in Entry Pocket	1	0	0	0	0	0	0	0	0	1	0	1
Entry Pocket Length [ft]	100.00	100.00	100.00	100.00	100.00	100.00	100.00	100.00	100.00	110.00	100.00	195.00
No. of Lanes in Exit Pocket	0	0	0	0	0	0	0	0	0	0	0	0
Exit Pocket Length [ft]	0.00	0.00	0.00	0.00	0.00	0.00	0.00	0.00	0.00	0.00	0.00	0.00
Speed [mph]	40.00			30.00			40.00			40.00		
Grade [%]	0.00			0.00			0.00			0.00		
Curb Present	Yes			Yes			Yes			Yes		
Crosswalk	Yes			Yes			Yes			No		





**Volumes**

Name	Airway Boulevard			Driveway			N. Canyons Parkway			N Canyons Parkway		
Base Volume Input [veh/h]	224	39	953	2	8	2	0	1547	671	827	127	9
Base Volume Adjustment Factor	1.0000	1.0000	1.0000	1.0000	1.0000	1.0000	1.0000	1.0000	1.0000	1.0000	1.0000	1.0000
Heavy Vehicles Percentage [%]	4.50	2.60	1.20	0.00	0.00	0.00	2.00	0.00	1.70	0.70	0.00	0.00
Proportion of CAVs [%]	0.00											
Growth Factor	1.0000	1.0000	1.0000	1.0000	1.0000	1.0000	1.0000	1.0000	1.0000	1.0000	1.0000	1.0000
In-Process Volume [veh/h]	0	0	0	0	0	0	0	0	0	0	0	0
Site-Generated Trips [veh/h]	0	0	0	0	0	0	0	0	0	0	0	0
Diverted Trips [veh/h]	0	0	0	0	0	0	0	0	0	0	0	0
Pass-by Trips [veh/h]	0	0	0	0	0	0	0	0	0	0	0	0
Existing Site Adjustment Volume [veh/h]	0	0	0	0	0	0	0	0	0	0	0	0
Other Volume [veh/h]	0	0	0	0	0	0	0	0	0	0	0	0
Right Turn on Red Volume [veh/h]	0	0	0	0	0	0	0	0	0	0	0	0
Total Hourly Volume [veh/h]	224	39	953	2	8	2	0	1547	671	827	127	9
Peak Hour Factor	0.9300	0.9300	0.9300	0.9300	0.9300	0.9300	1.0000	0.9300	0.9300	0.9300	0.9300	0.9300
Other Adjustment Factor	1.0000	1.0000	1.0000	1.0000	1.0000	1.0000	1.0000	1.0000	1.0000	1.0000	1.0000	1.0000
Total 15-Minute Volume [veh/h]	60	10	256	1	2	1	0	416	180	222	34	2
Total Analysis Volume [veh/h]	241	42	1025	2	9	2	0	1663	722	889	137	10
Presence of On-Street Parking	No		No	No		No	No		No	No		No
On-Street Parking Maneuver Rate [/h]	0	0	0	0	0	0	0	0	0	0	0	0
Local Bus Stopping Rate [/h]	0	0	0	0	0	0	0	0	0	0	0	0
v_do, Outbound Pedestrian Volume crossing	2			0			1			0		
v_di, Inbound Pedestrian Volume crossing m	1			0			2			0		
v_co, Outbound Pedestrian Volume crossing	0			0			0			0		
v_ci, Inbound Pedestrian Volume crossing mi	0			0			0			0		
v_ab, Corner Pedestrian Volume [ped/h]	0			0			0			0		
Bicycle Volume [bicycles/h]	0			0			0			0		



**Intersection Settings**

Located in CBD	No
Signal Coordination Group	-
Cycle Length [s]	105
Active Pattern	Pattern 1
Coordination Type	Time of Day Pattern Coordinated
Actuation Type	Fully actuated
Offset [s]	100.0
Offset Reference	Lead Green - Beginning of First Green
Permissive Mode	SingleBand
Lost time [s]	12.00

**Phasing & Timing (Basic)**

Control Type	Split	Split	Overlap	Split	Split	Split	Permiss	Permiss	Permiss	Protecte	Permiss	Permiss
Signal Group	0	8	8	0	4	0	0	2	0	1	6	0
Auxiliary Signal Groups			1,8									
Maximum Green [s]	0	20	20	0	12	0	0	15	0	50	50	0
Amber [s]	0.0	3.2	3.2	0.0	3.0	0.0	0.0	5.0	0.0	5.0	5.0	0.0
All red [s]	0.0	1.0	1.0	0.0	1.0	0.0	0.0	1.0	0.0	1.0	1.0	0.0
Walk [s]	0	0	0	0	5	0	0	5	0	0	5	0
Pedestrian Clearance [s]	0	0	0	0	28	0	0	29	0	0	12	0
Delayed Vehicle Green [s]	0.0	0.0	0.0	0.0	0.0	0.0	0.0	0.0	0.0	0.0	0.0	0.0
Rest In Walk		No			No			No			No	
I1, Start-Up Lost Time [s]	0.0	2.0	2.0	0.0	2.0	0.0	0.0	2.0	0.0	2.0	2.0	0.0
I2, Clearance Lost Time [s]	0.0	2.0	2.0	0.0	2.0	0.0	0.0	2.0	0.0	2.0	2.0	0.0
Detector Location [ft]	0.0	0.0	0.0	0.0	0.0	0.0	0.0	0.0	0.0	0.0	0.0	0.0
Detector Length [ft]	0.0	0.0	0.0	0.0	20.0	0.0	0.0	20.0	0.0	0.0	0.0	0.0
I, Upstream Filtering Factor	1.00	1.00	1.00	1.00	1.00	1.00	1.00	1.00	1.00	1.00	1.00	1.00

**Phasing & Timing: Pattern 1**

Split [s]	0	9	9	0	37	0	0	40	0	19	59	0
Lead / Lag	-	-	-	-	-	-	-	-	-	Lead	-	-
Minimum Green [s]	0	4	4	0	3	0	0	10	0	3	7	0
Vehicle Extension [s]	0.0	2.0	2.0	0.0	2.0	0.0	0.0	2.0	0.0	2.0	2.0	0.0
Minimum Recall		No	No		No			No		No	Yes	
Maximum Recall		No	No		No			No		Yes	Yes	
Pedestrian Recall		No	No		No			No		No	No	

**Exclusive Pedestrian Phase**

Pedestrian Signal Group	0
Pedestrian Walk [s]	0
Pedestrian Clearance [s]	0



**Lane Group Calculations**

Lane Group	L	C	R	C	C	R	L	C	C
C, Cycle Length [s]	105	105	105	105	105	105	105	105	105
L, Total Lost Time per Cycle [s]	4.00	4.00	4.00	4.00	4.00	4.00	4.00	4.00	4.00
l1_p, Permitted Start-Up Lost Time [s]	0.00	0.00	0.00	0.00	0.00	0.00	0.00	0.00	0.00
l2, Clearance Lost Time [s]	2.00	2.00	0.00	2.00	2.00	2.00	2.00	2.00	2.00
g_i, Effective Green Time [s]	32	32	56	1	36	36	20	60	60
g / C, Green / Cycle	0.31	0.31	0.53	0.01	0.34	0.34	0.19	0.57	0.57
(v / s)_i Volume / Saturation Flow Rate	0.08	0.08	0.36	0.01	0.46	0.45	0.25	0.04	0.04
s, saturation flow rate [veh/h]	1745	1798	2831	1836	3618	1589	3495	1900	1855
c, Capacity [veh/h]	537	553	1458	17	1239	544	658	1081	1055
d1, Uniform Delay [s]	27.37	27.34	19.36	51.92	34.52	34.47	42.62	10.15	10.15
k, delay calibration	0.04	0.04	0.50	0.04	0.20	0.50	0.50	0.50	0.50
l, Upstream Filtering Factor	1.00	1.00	1.00	1.00	1.00	1.00	1.00	1.00	1.00
d2, Incremental Delay [s]	0.10	0.09	2.86	24.09	156.03	159.17	167.93	0.12	0.13
d3, Initial Queue Delay [s]	0.00	0.00	0.00	0.00	0.00	0.00	0.00	0.00	0.00
Rp, platoon ratio	1.00	1.00	1.00	1.00	1.00	1.00	1.00	1.00	1.00
PF, progression factor	1.00	1.00	1.00	1.00	1.00	1.00	1.00	1.00	1.00

**Lane Group Results**

X, volume / capacity	0.26	0.26	0.70	0.78	1.34	1.33	1.35	0.07	0.07
d, Delay for Lane Group [s/veh]	27.47	27.43	22.22	76.01	190.55	193.64	210.55	10.28	10.28
Lane Group LOS	C	C	C	E	F	F	F	B	B
Critical Lane Group	No	No	Yes	Yes	Yes	No	Yes	No	No
50th-Percentile Queue Length [veh/ln]	2.58	2.62	9.26	0.45	41.78	37.17	23.60	0.75	0.74
50th-Percentile Queue Length [ft/ln]	64.61	65.52	231.62	11.32	1044.59	929.16	589.99	18.84	18.42
95th-Percentile Queue Length [veh/ln]	4.65	4.72	14.26	0.82	62.20	55.62	36.20	1.36	1.33
95th-Percentile Queue Length [ft/ln]	116.30	117.94	356.42	20.38	1555.08	1390.38	904.90	33.91	33.15



**Movement, Approach, & Intersection Results**

d_M, Delay for Movement [s/veh]	27.47	27.43	22.22	76.01	76.01	76.01	0.00	190.55	193.64	210.55	10.28	10.28
Movement LOS	C	C	C	E	E	E		F	F	F	B	B
d_A, Approach Delay [s/veh]	23.35			76.01				191.49		182.13		
Approach LOS	C			E				F		F		
d_I, Intersection Delay [s/veh]	142.75											
Intersection LOS	F											
Intersection V/C	1.146											

**Emissions**

Vehicle Miles Traveled [mph]	16.67	16.93	121.71	0.45	108.40	47.06	72.71	6.08	5.94
Stops [stops/h]	88.60	89.86	635.27	15.52	2864.99	1274.20	1618.16	25.84	25.26
Fuel consumption [US gal/h]	2.25	2.29	15.24	0.31	96.50	42.65	56.58	0.63	0.61
CO [g/h]	157.44	159.73	1064.97	21.34	6745.39	2981.18	3955.22	43.84	42.83
NOx [g/h]	30.63	31.08	207.20	4.15	1312.41	580.03	769.54	8.53	8.33
VOC [g/h]	36.49	37.02	246.82	4.94	1563.31	690.92	916.66	10.16	9.93

**Other Modes**

g_Walk,mi, Effective Walk Time [s]	9.0	9.0	9.0	0.0
M_corner, Corner Circulation Area [ft <sup>2</sup> /ped]	0.00	0.00	0.00	0.00
M_CW, Crosswalk Circulation Area [ft <sup>2</sup> /ped]	0.00	0.00	0.00	0.00
d_p, Pedestrian Delay [s]	43.89	43.89	43.89	0.00
I_p,int, Pedestrian LOS Score for Intersectio	3.147	1.756	3.028	0.000
Crosswalk LOS	C	A	C	F
s_b, Saturation Flow Rate of the bicycle lane	2000	2000	2000	2000
c_b, Capacity of the bicycle lane [bicycles/h]	91	629	648	1009
d_b, Bicycle Delay [s]	47.81	24.69	24.01	12.88
I_b,int, Bicycle LOS Score for Intersection	3.718	1.581	3.527	2.414
Bicycle LOS	D	A	D	B

**Sequence**

Ring 1	1	2	4	8	-	-	-	-	-	-	-	-	-	-	-
Ring 2	-	6	-	-	-	-	-	-	-	-	-	-	-	-	-
Ring 3	-	-	-	-	-	-	-	-	-	-	-	-	-	-	-
Ring 4	-	-	-	-	-	-	-	-	-	-	-	-	-	-	-

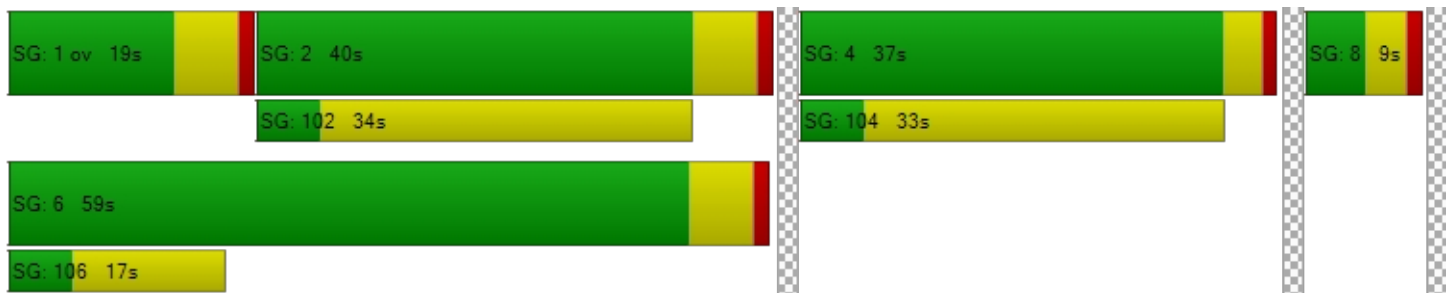

**Intersection Level Of Service Report**  
**Intersection 17: Airway Boulevard & I-580 WB Ramps**

Control Type:	Signalized	Delay (sec / veh):	9.2
Analysis Method:	HCM 7th Edition	Level Of Service:	A
Analysis Period:	15 minutes	Volume to Capacity (v/c):	0.383

**Intersection Setup**

Name	Airway Boulevard			Airway Boulevard			I-580 WB On-Ramp			I-580 WB Off-Ramp		
Approach	Northbound			Southbound			Eastbound			Westbound		
Lane Configuration	r			r						r rr		
Turning Movement	Left	Thru	Right	Left	Thru	Right	Left	Thru	Right	Left	Thru	Right
Lane Width [ft]	12.00	12.00	12.00	12.00	12.00	12.00	12.00	12.00	12.00	12.00	12.00	12.00
No. of Lanes in Entry Pocket	0	0	0	0	0	1	0	0	0	1	0	1
Entry Pocket Length [ft]	100.00	100.00	100.00	100.00	100.00	250.00	100.00	100.00	100.00	150.00	100.00	490.00
No. of Lanes in Exit Pocket	0	0	0	0	0	0	0	0	0	0	0	0
Exit Pocket Length [ft]	0.00	0.00	0.00	0.00	0.00	0.00	0.00	0.00	0.00	0.00	0.00	0.00
Speed [mph]	40.00			40.00			30.00			45.00		
Grade [%]	0.00			0.00			0.00			0.00		
Curb Present	Yes			Yes						Yes		
Crosswalk	No			No			No			Yes		



**Volumes**

Name	Airway Boulevard			Airway Boulevard			I-580 WB On-Ramp			I-580 WB Off-Ramp		
	Base Volume Input [veh/h]	0	1077	227	0	769	821	0	0	0	54	0
Base Volume Adjustment Factor	1.0000	1.0000	1.0000	1.0000	1.0000	1.0000	1.0000	1.0000	1.0000	1.0000	1.0000	1.0000
Heavy Vehicles Percentage [%]	2.00	1.20	0.00	2.00	0.40	0.70	2.00	2.00	2.00	0.00	0.00	1.10
Proportion of CAVs [%]	0.00											
Growth Factor	1.0000	1.0000	1.0000	1.0000	1.0000	1.0000	1.0000	1.0000	1.0000	1.0000	1.0000	1.0000
In-Process Volume [veh/h]	0	0	0	0	0	0	0	0	0	0	0	0
Site-Generated Trips [veh/h]	0	0	0	0	0	0	0	0	0	0	0	0
Diverted Trips [veh/h]	0	0	0	0	0	0	0	0	0	0	0	0
Pass-by Trips [veh/h]	0	0	0	0	0	0	0	0	0	0	0	0
Existing Site Adjustment Volume [veh/h]	0	0	0	0	0	0	0	0	0	0	0	0
Other Volume [veh/h]	0	0	0	0	0	0	0	0	0	0	0	0
Right Turn on Red Volume [veh/h]	0	0	0	0	0	0	0	0	0	0	0	0
Total Hourly Volume [veh/h]	0	1077	227	0	769	821	0	0	0	54	0	264
Peak Hour Factor	1.0000	0.8900	0.8900	1.0000	0.8900	0.8900	1.0000	1.0000	1.0000	0.8900	0.8900	0.8900
Other Adjustment Factor	1.0000	1.0000	1.0000	1.0000	1.0000	1.0000	1.0000	1.0000	1.0000	1.0000	1.0000	1.0000
Total 15-Minute Volume [veh/h]	0	303	64	0	216	231	0	0	0	15	0	74
Total Analysis Volume [veh/h]	0	1210	255	0	864	922	0	0	0	61	0	297
Presence of On-Street Parking	No		No	No		No				No		No
On-Street Parking Maneuver Rate [/h]	0	0	0	0	0	0	0	0	0	0	0	0
Local Bus Stopping Rate [/h]	0	0	0	0	0	0	0	0	0	0	0	0
v_do, Outbound Pedestrian Volume crossing	0			0			0			0		
v_di, Inbound Pedestrian Volume crossing m	0			0			0			0		
v_co, Outbound Pedestrian Volume crossing	0			0			0			0		
v_ci, Inbound Pedestrian Volume crossing mi	0			0			0			0		
v_ab, Corner Pedestrian Volume [ped/h]	0			0			0			0		
Bicycle Volume [bicycles/h]	1			0			0			0		



**Intersection Settings**

Located in CBD	No
Signal Coordination Group	-
Cycle Length [s]	105
Active Pattern	Pattern 1
Coordination Type	Time of Day Pattern Coordinated
Actuation Type	Fully actuated
Offset [s]	35.0
Offset Reference	Lead Green - Beginning of First Green
Permissive Mode	SingleBand
Lost time [s]	9.00

**Phasing & Timing (Basic)**

Control Type	Permiss	Permiss	Unsigna	Permiss	Permiss	Unsigna	Permiss	Permiss	Permiss	Permiss	Permiss	Overlap
Signal Group	0	2	0	0	6	0	0	0	0	0	8	1
Auxiliary Signal Groups												1,8
Maximum Green [s]	0	30	0	0	25	0	0	0	0	0	20	12
Amber [s]	0.0	4.3	0.0	0.0	4.3	0.0	0.0	0.0	0.0	0.0	3.0	3.0
All red [s]	0.0	1.0	0.0	0.0	1.0	0.0	0.0	0.0	0.0	0.0	1.0	0.0
Walk [s]	0	7	0	0	0	0	0	0	0	0	0	0
Pedestrian Clearance [s]	0	15	0	0	0	0	0	0	0	0	0	0
Delayed Vehicle Green [s]	0.0	0.0	0.0	0.0	0.0	0.0	0.0	0.0	0.0	0.0	0.0	0.0
Rest In Walk		No			No						No	
I1, Start-Up Lost Time [s]	0.0	2.0	0.0	0.0	2.0	0.0	0.0	0.0	0.0	0.0	2.0	2.0
I2, Clearance Lost Time [s]	0.0	2.0	0.0	0.0	2.0	0.0	0.0	0.0	0.0	0.0	2.0	2.0
Detector Location [ft]	0.0	0.0	0.0	0.0	0.0	0.0	0.0	0.0	0.0	0.0	0.0	0.0
Detector Length [ft]	0.0	20.0	0.0	0.0	20.0	0.0	0.0	0.0	0.0	0.0	20.0	20.0
I, Upstream Filtering Factor	1.00	1.00	1.00	1.00	1.00	1.00	1.00	1.00	1.00	1.00	1.00	1.00

**Phasing & Timing: Pattern 1**

Split [s]	0	68	0	0	83	0	0	0	0	0	22	15
Lead / Lag	-	-	-	-	-	-	-	-	-	-	-	-
Minimum Green [s]	0	11	0	0	8	0	0	0	0	0	4	4
Vehicle Extension [s]	0.0	0.0	0.0	0.0	0.0	0.0	0.0	0.0	0.0	0.0	0.0	0.0
Minimum Recall		Yes			Yes						No	No
Maximum Recall		No			No						No	No
Pedestrian Recall		No			No						No	No

**Exclusive Pedestrian Phase**

Pedestrian Signal Group	0
Pedestrian Walk [s]	0
Pedestrian Clearance [s]	0



**Lane Group Calculations**

Lane Group	C	C		L	C	R
C, Cycle Length [s]	105	105		105	105	105
L, Total Lost Time per Cycle [s]	4.00	4.00		4.00	4.00	4.00
l1_p, Permitted Start-Up Lost Time [s]	0.00	0.00		0.00	0.00	0.00
l2, Clearance Lost Time [s]	2.00	2.00		2.00	2.00	0.00
g_i, Effective Green Time [s]	72	86		11	11	25
g / C, Green / Cycle	0.68	0.82		0.11	0.11	0.24
(v / s)_i Volume / Saturation Flow Rate	0.34	0.17		0.02	0.02	0.10
s, saturation flow rate [veh/h]	3583	5159		1810	1810	2834
c, Capacity [veh/h]	2445	4216		193	193	711
d1, Uniform Delay [s]	7.99	2.10		42.58	42.58	32.88
k, delay calibration	0.50	0.50		0.04	0.04	0.04
l, Upstream Filtering Factor	1.00	1.00		1.00	1.00	1.00
d2, Incremental Delay [s]	0.72	0.11		0.14	0.14	0.15
d3, Initial Queue Delay [s]	0.00	0.00		0.00	0.00	0.00
Rp, platoon ratio	1.00	1.00		1.00	1.00	1.00
PF, progression factor	1.00	1.00		1.00	1.00	1.00

**Lane Group Results**

X, volume / capacity	0.49	0.20		0.16	0.16	0.42
d, Delay for Lane Group [s/veh]	8.70	2.21		42.72	42.72	33.02
Lane Group LOS	A	A		D	D	C
Critical Lane Group	Yes	No		No	No	Yes
50th-Percentile Queue Length [veh/ln]	5.66	0.73		0.70	0.70	3.04
50th-Percentile Queue Length [ft/ln]	141.45	18.30		17.62	17.62	76.10
95th-Percentile Queue Length [veh/ln]	9.56	1.32		1.27	1.27	5.48
95th-Percentile Queue Length [ft/ln]	238.98	32.94		31.72	31.72	136.99



**Movement, Approach, & Intersection Results**

d_M, Delay for Movement [s/veh]	0.00	8.70	0.00	0.00	2.21	0.00	0.00	0.00	0.00	42.72	42.72	33.02
Movement LOS		A			A					D	D	C
d_A, Approach Delay [s/veh]	7.33		1.14			0.00			34.68			
Approach LOS	A		A			A			C			
d_I, Intersection Delay [s/veh]	9.15											
Intersection LOS	A											
Intersection V/C	0.383											

**Emissions**

Vehicle Miles Traveled [mph]	100.94	102.59	3.00	3.00	29.21
Stops [stops/h]	388.21	75.33	24.18	24.18	208.86
Fuel consumption [US gal/h]	9.57	4.80	0.67	0.67	5.59
CO [g/h]	669.13	335.82	46.74	46.74	391.02
NOx [g/h]	130.19	65.34	9.09	9.09	76.08
VOC [g/h]	155.08	77.83	10.83	10.83	90.62

**Other Modes**

g_Walk,mi, Effective Walk Time [s]	0.0	0.0	0.0	11.0
M_corner, Corner Circulation Area [ft <sup>2</sup> /ped]	0.00	0.00	0.00	0.00
M_CW, Crosswalk Circulation Area [ft <sup>2</sup> /ped]	0.00	0.00	0.00	0.00
d_p, Pedestrian Delay [s]	0.00	0.00	0.00	42.05
I_p,int, Pedestrian LOS Score for Intersectio	0.000	0.000	0.000	2.412
Crosswalk LOS	F	F	F	B
s_b, Saturation Flow Rate of the bicycle lane	2000	2000	2000	2000
c_b, Capacity of the bicycle lane [bicycles/h]	1195	1481	0	343
d_b, Bicycle Delay [s]	8.51	3.54	52.47	36.01
I_b,int, Bicycle LOS Score for Intersection	2.558	2.035	4.132	2.150
Bicycle LOS	B	B	D	B

**Sequence**

Ring 1	1	2	-	-	-	-	-	-	-	-	-	-	-	-	-
Ring 2	-	6	-	8	-	-	-	-	-	-	-	-	-	-	-
Ring 3	-	-	-	-	-	-	-	-	-	-	-	-	-	-	-
Ring 4	-	-	-	-	-	-	-	-	-	-	-	-	-	-	-



**Intersection Level Of Service Report**

**Intersection 18: Dublin Boulevard & Commercial Access Driveway**

Control Type:	Signalized	Delay (sec / veh):	54.9
Analysis Method:	HCM 7th Edition	Level Of Service:	D
Analysis Period:	15 minutes	Volume to Capacity (v/c):	0.954

**Intersection Setup**

Name	Project Access			Project Access			Dublin Boulevard			Dublin Boulevard		
Approach	Northbound			Southbound			Eastbound			Westbound		
Lane Configuration	⇐⇐⇐			⇐⇐⇐			⇐⇐⇐			⇐⇐⇐		
Turning Movement	Left	Thru	Right	Left	Thru	Right	Left	Thru	Right	Left	Thru	Right
Lane Width [ft]	12.00	12.00	12.00	12.00	12.00	12.00	12.00	12.00	12.00	12.00	12.00	12.00
No. of Lanes in Entry Pocket	1	0	0	1	0	1	1	0	1	1	0	0
Entry Pocket Length [ft]	100.00	100.00	100.00	100.00	100.00	100.00	100.00	100.00	100.00	100.00	100.00	100.00
No. of Lanes in Exit Pocket	0	0	0	0	0	0	0	0	0	0	0	0
Exit Pocket Length [ft]	0.00	0.00	0.00	0.00	0.00	0.00	0.00	0.00	0.00	0.00	0.00	0.00
Speed [mph]	30.00			30.00			30.00			45.00		
Grade [%]	0.00			0.00			0.00			0.00		
Curb Present	No			No			No			No		
Crosswalk	Yes			Yes			Yes			Yes		



**Volumes**

Name	Project Access			Project Access			Dublin Boulevard			Dublin Boulevard		
Base Volume Input [veh/h]	644	8	0	42	8	202	68	2025	202	0	582	23
Base Volume Adjustment Factor	1.0000	1.0000	1.0000	1.0000	1.0000	1.0000	1.0000	1.0000	1.0000	1.0000	1.0000	1.0000
Heavy Vehicles Percentage [%]	2.00	2.00	2.00	2.00	2.00	2.00	2.00	2.00	2.00	2.00	2.00	2.00
Proportion of CAVs [%]	0.00											
Growth Factor	1.0000	1.0000	1.0000	1.0000	1.0000	1.0000	1.0000	1.0000	1.0000	1.0000	1.0000	1.0000
In-Process Volume [veh/h]	0	0	0	0	0	0	0	0	0	0	0	0
Site-Generated Trips [veh/h]	0	0	0	0	0	0	0	0	0	0	0	0
Diverted Trips [veh/h]	0	0	0	0	0	0	0	0	0	0	0	0
Pass-by Trips [veh/h]	0	0	0	0	0	0	0	0	0	0	0	0
Existing Site Adjustment Volume [veh/h]	0	0	0	0	0	0	0	0	0	0	0	0
Other Volume [veh/h]	0	0	0	0	0	0	0	0	0	0	0	0
Right Turn on Red Volume [veh/h]	0	0	0	0	0	0	0	0	0	0	0	0
Total Hourly Volume [veh/h]	644	8	0	42	8	202	68	2025	202	0	582	23
Peak Hour Factor	1.0000	1.0000	1.0000	1.0000	1.0000	1.0000	1.0000	1.0000	1.0000	1.0000	1.0000	1.0000
Other Adjustment Factor	1.0000	1.0000	1.0000	1.0000	1.0000	1.0000	1.0000	1.0000	1.0000	1.0000	1.0000	1.0000
Total 15-Minute Volume [veh/h]	161	2	0	11	2	51	17	506	51	0	146	6
Total Analysis Volume [veh/h]	644	8	0	42	8	202	68	2025	202	0	582	23
Presence of On-Street Parking	No		No	No		No	No		No	No		No
On-Street Parking Maneuver Rate [/h]	0	0	0	0	0	0	0	0	0	0	0	0
Local Bus Stopping Rate [/h]	0	0	0	0	0	0	0	0	0	0	0	0
v_do, Outbound Pedestrian Volume crossing	0			0			0			0		
v_di, Inbound Pedestrian Volume crossing m	0			0			0			0		
v_co, Outbound Pedestrian Volume crossing	0			0			0			0		
v_ci, Inbound Pedestrian Volume crossing mi	0			0			0			0		
v_ab, Corner Pedestrian Volume [ped/h]	0			0			0			0		
Bicycle Volume [bicycles/h]	0			0			0			0		



**Intersection Settings**

Located in CBD	No
Signal Coordination Group	-
Cycle Length [s]	160
Active Pattern	Pattern 1
Coordination Type	Time of Day Pattern Isolated
Actuation Type	Fully actuated
Offset [s]	0.0
Offset Reference	Lead Green - Beginning of First Green
Permissive Mode	SingleBand
Lost time [s]	12.00

**Phasing & Timing (Basic)**

Control Type	Protecte	Permiss	Permiss	Protecte	Permiss	Permiss	Protecte	Permiss	Permiss	Protecte	Permiss	Permiss
Signal Group	1	6	0	5	2	2	3	8	0	7	4	0
Auxiliary Signal Groups												
Maximum Green [s]	5	26	0	5	26	26	5	206	0	5	206	0
Amber [s]	3.0	3.0	0.0	3.0	3.0	3.0	3.0	3.0	0.0	3.0	3.0	0.0
All red [s]	1.0	1.0	0.0	1.0	1.0	1.0	1.0	1.0	0.0	1.0	1.0	0.0
Walk [s]	0	5	0	0	5	5	0	5	0	0	5	0
Pedestrian Clearance [s]	0	17	0	0	21	21	0	10	0	0	10	0
Delayed Vehicle Green [s]	0.0	0.0	0.0	0.0	0.0	0.0	0.0	0.0	0.0	0.0	0.0	0.0
Rest In Walk		No			No			No			No	
I1, Start-Up Lost Time [s]	2.0	2.0	0.0	2.0	2.0	2.0	2.0	2.0	0.0	2.0	2.0	0.0
I2, Clearance Lost Time [s]	2.0	2.0	0.0	2.0	2.0	2.0	2.0	2.0	0.0	2.0	2.0	0.0
Detector Location [ft]	0.0	0.0	0.0	0.0	0.0	0.0	0.0	0.0	0.0	0.0	0.0	0.0
Detector Length [ft]	20.0	20.0	0.0	20.0	20.0	20.0	0.0	0.0	0.0	20.0	20.0	0.0
I, Upstream Filtering Factor	1.00	1.00	1.00	1.00	1.00	1.00	1.00	1.00	1.00	1.00	1.00	1.00

**Phasing & Timing: Pattern 1**

Split [s]	33	26	0	37	30	30	55	88	0	9	42	0
Lead / Lag	Lead	-	-	Lead	-	-	Lead	-	-	Lead	-	-
Minimum Green [s]	5	10	0	5	10	10	5	10	0	5	10	0
Vehicle Extension [s]	3.0	3.0	0.0	3.0	3.0	3.0	3.0	3.0	0.0	3.0	3.0	0.0
Minimum Recall	No	No		No	No		No	No		No	No	
Maximum Recall	No	No		No	No		No	No		No	No	
Pedestrian Recall	No	No		No	No		No	No		No	No	

**Exclusive Pedestrian Phase**

Pedestrian Signal Group	0
Pedestrian Walk [s]	0
Pedestrian Clearance [s]	0



**Lane Group Calculations**

Lane Group	L	C	L	C	R	L	C	R	L	C	C
C, Cycle Length [s]	160	160	160	160	160	160	160	160	160	160	160
L, Total Lost Time per Cycle [s]	4.00	4.00	4.00	4.00	4.00	4.00	4.00	4.00	4.00	4.00	4.00
l1_p, Permitted Start-Up Lost Time [s]	0.00	0.00	0.00	0.00	0.00	0.00	0.00	0.00	0.00	0.00	0.00
l2, Clearance Lost Time [s]	2.00	2.00	2.00	2.00	2.00	2.00	2.00	2.00	2.00	2.00	2.00
g_i, Effective Green Time [s]	29	50	5	26	26	8	89	89	0	81	81
g / C, Green / Cycle	0.18	0.31	0.03	0.16	0.16	0.05	0.56	0.56	0.00	0.51	0.51
(v / s)_i Volume / Saturation Flow Rate	0.19	0.00	0.02	0.00	0.13	0.04	0.57	0.13	0.00	0.16	0.16
s, saturation flow rate [veh/h]	3459	1870	1781	1870	1589	1781	3560	1589	1781	1870	1845
c, Capacity [veh/h]	623	585	55	306	260	87	1981	884	0	949	936
d1, Uniform Delay [s]	65.60	37.94	76.98	56.23	64.14	75.29	35.51	18.05	0.00	23.18	23.18
k, delay calibration	0.11	0.50	0.11	0.50	0.50	0.11	0.11	0.11	0.11	0.11	0.11
l, Upstream Filtering Factor	1.00	1.00	1.00	1.00	1.00	1.00	1.00	1.00	1.00	1.00	1.00
d2, Incremental Delay [s]	26.09	0.04	19.43	0.16	20.11	14.17	15.81	0.13	0.00	0.19	0.20
d3, Initial Queue Delay [s]	0.00	0.00	0.00	0.00	0.00	0.00	0.00	0.00	0.00	0.00	0.00
Rp, platoon ratio	1.00	1.00	1.00	1.00	1.00	1.00	1.00	1.00	1.00	1.00	1.00
PF, progression factor	1.00	1.00	1.00	1.00	1.00	1.00	1.00	1.00	1.00	1.00	1.00

**Lane Group Results**

X, volume / capacity	1.03	0.01	0.76	0.03	0.78	0.78	1.02	0.23	0.00	0.32	0.32
d, Delay for Lane Group [s/veh]	91.69	37.99	96.41	56.39	84.25	89.46	51.32	18.18	0.00	23.37	23.38
Lane Group LOS	F	D	F	E	F	F	F	B	A	C	C
Critical Lane Group	Yes	No	No	No	Yes	No	Yes	No	No	No	No
50th-Percentile Queue Length [veh/ln]	15.01	0.23	2.03	0.29	9.39	3.13	41.93	3.93	0.00	6.71	6.64
50th-Percentile Queue Length [ft/ln]	375.15	5.73	50.64	7.23	234.85	78.18	1048.33	98.23	0.00	167.73	165.89
95th-Percentile Queue Length [veh/ln]	21.73	0.41	3.65	0.52	14.42	5.63	53.58	7.07	0.00	10.96	10.86
95th-Percentile Queue Length [ft/ln]	543.25	10.31	91.15	13.01	360.52	140.73	1339.43	176.81	0.00	273.92	271.50



**Movement, Approach, & Intersection Results**

d_M, Delay for Movement [s/veh]	91.69	37.99	37.99	96.41	56.39	84.25	89.46	51.32	18.18	0.00	23.37	23.38
Movement LOS	F	D	D	F	E	F	F	F	B	A	C	C
d_A, Approach Delay [s/veh]	91.04			85.40			49.53			23.37		
Approach LOS	F			F			D			C		
d_I, Intersection Delay [s/veh]	54.86											
Intersection LOS	D											
Intersection V/C	0.954											

**Emissions**

Vehicle Miles Traveled [mph]	51.36	0.64	1.90	0.36	9.11	15.26	454.43	45.33	0.00	93.78	92.71
Stops [stops/h]	675.16	5.15	45.57	6.51	211.34	70.35	1886.70	88.39	0.00	150.93	149.28
Fuel consumption [US gal/h]	17.86	0.12	1.15	0.14	5.01	2.25	50.28	3.10	0.00	6.54	6.46
CO [g/h]	1248.37	8.15	80.64	9.97	349.90	157.60	3514.29	216.81	0.00	457.00	451.89
NOx [g/h]	242.89	1.59	15.69	1.94	68.08	30.66	683.75	42.18	0.00	88.92	87.92
VOC [g/h]	289.32	1.89	18.69	2.31	81.09	36.53	814.47	50.25	0.00	105.91	104.73

**Other Modes**

g_Walk,mi, Effective Walk Time [s]	9.0	9.0	9.0	9.0
M_corner, Corner Circulation Area [ft <sup>2</sup> /ped]	0.00	0.00	0.00	0.00
M_CW, Crosswalk Circulation Area [ft <sup>2</sup> /ped]	0.00	0.00	0.00	0.00
d_p, Pedestrian Delay [s]	71.27	71.27	71.27	71.27
I_p,int, Pedestrian LOS Score for Intersectio	2.370	2.245	3.208	3.110
Crosswalk LOS	B	B	C	C
s_b, Saturation Flow Rate of the bicycle lane	2000	2000	2000	2000
c_b, Capacity of the bicycle lane [bicycles/h]	275	325	1050	475
d_b, Bicycle Delay [s]	59.52	56.12	18.06	46.52
I_b,int, Bicycle LOS Score for Intersection	2.635	1.975	3.453	2.059
Bicycle LOS	B	A	C	B

**Sequence**

Ring 1	1	2	3	4	-	-	-	-	-	-	-	-	-	-	-
Ring 2	5	6	7	8	-	-	-	-	-	-	-	-	-	-	-
Ring 3	-	-	-	-	-	-	-	-	-	-	-	-	-	-	-
Ring 4	-	-	-	-	-	-	-	-	-	-	-	-	-	-	-

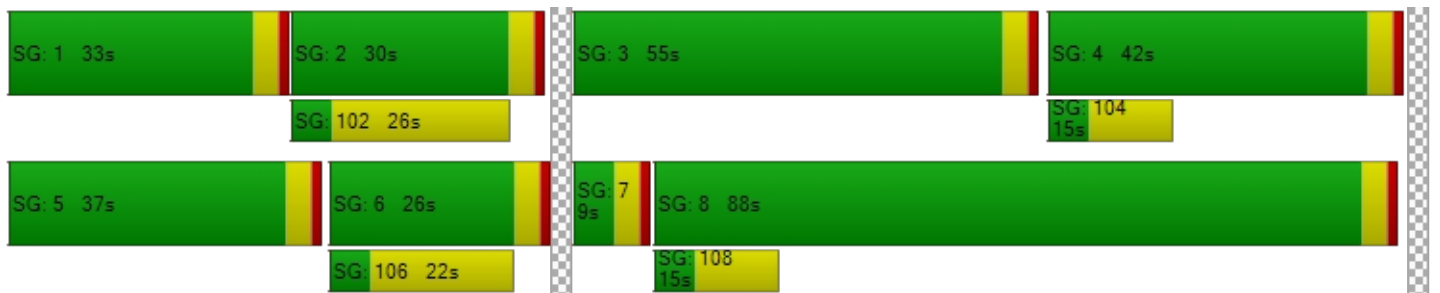

**Intersection Level Of Service Report**

**Intersection 19: Pandora Way & Residential Project Access Driveway (Parcel 7)**

Control Type:	All-way stop	Delay (sec / veh):	7.1
Analysis Method:	HCM 7th Edition	Level Of Service:	A
Analysis Period:	15 minutes	Volume to Capacity (v/c):	0.055

**Intersection Setup**

Name	Residential Project Access (Parcel 7)		Pino Grande Road		Pandora Way	
Approach	Northbound		Southbound		Westbound	
Lane Configuration	↬		↵		↶	
Turning Movement	Thru	Right	Left	Thru	Left	Right
Lane Width [ft]	12.00	12.00	12.00	12.00	12.00	12.00
No. of Lanes in Entry Pocket	0	0	0	0	0	0
Entry Pocket Length [ft]	100.00	100.00	100.00	100.00	100.00	100.00
No. of Lanes in Exit Pocket	0	0	0	0	0	0
Exit Pocket Length [ft]	0.00	0.00	0.00	0.00	0.00	0.00
Speed [mph]	30.00		30.00		30.00	
Grade [%]	0.00		0.00		0.00	
Crosswalk	Yes		Yes		Yes	

**Volumes**

Name	Residential Project Access (Parcel 7)		Pino Grande Road		Pandora Way	
Base Volume Input [veh/h]	10	0	5	45	0	5
Base Volume Adjustment Factor	1.0000	1.0000	1.0000	1.0000	1.0000	1.0000
Heavy Vehicles Percentage [%]	2.00	2.00	2.00	2.00	2.00	2.00
Growth Factor	1.0000	1.0000	1.0000	1.0000	1.0000	1.0000
In-Process Volume [veh/h]	0	0	0	0	0	0
Site-Generated Trips [veh/h]	0	0	0	0	0	0
Diverted Trips [veh/h]	0	0	0	0	0	0
Pass-by Trips [veh/h]	0	0	0	0	0	0
Existing Site Adjustment Volume [veh/h]	0	0	0	0	0	0
Other Volume [veh/h]	0	0	0	0	0	0
Total Hourly Volume [veh/h]	10	0	5	45	0	5
Peak Hour Factor	1.0000	1.0000	1.0000	1.0000	1.0000	1.0000
Other Adjustment Factor	1.0000	1.0000	1.0000	1.0000	1.0000	1.0000
Total 15-Minute Volume [veh/h]	3	0	1	11	0	1
Total Analysis Volume [veh/h]	10	0	5	45	0	5
Pedestrian Volume [ped/h]	0		0		0	



**Intersection Settings****Lanes**

Capacity per Entry Lane [veh/h]	903	906	1041
Degree of Utilization, x	0.01	0.06	0.00

**Movement, Approach, & Intersection Results**

95th-Percentile Queue Length [veh]	0.03	0.17	0.01
95th-Percentile Queue Length [ft]	0.84	4.37	0.36
Approach Delay [s/veh]	7.03	7.20	6.48
Approach LOS	A	A	A
Intersection Delay [s/veh]	7.12		
Intersection LOS	A		



**Intersection Level Of Service Report**  
**Intersection 20: Croak Road & Central Parkway**

Control Type:	All-way stop	Delay (sec / veh):	14.0
Analysis Method:	HCM 7th Edition	Level Of Service:	B
Analysis Period:	15 minutes	Volume to Capacity (v/c):	0.611

**Intersection Setup**

Name	Croak Road			Croak Road			Central Parkway			Westbound		
Approach	Northbound			Southbound			Eastbound			Westbound		
Lane Configuration	+			+			+			+		
Turning Movement	Left	Thru	Right	Left	Thru	Right	Left	Thru	Right	Left	Thru	Right
Lane Width [ft]	12.00	12.00	12.00	12.00	12.00	12.00	12.00	12.00	12.00	12.00	12.00	12.00
No. of Lanes in Entry Pocket	0	0	0	0	0	0	0	0	0	0	0	0
Entry Pocket Length [ft]	100.00	100.00	100.00	100.00	100.00	100.00	100.00	100.00	100.00	100.00	100.00	100.00
No. of Lanes in Exit Pocket	0	0	0	0	0	0	0	0	0	0	0	0
Exit Pocket Length [ft]	0.00	0.00	0.00	0.00	0.00	0.00	0.00	0.00	0.00	0.00	0.00	0.00
Speed [mph]	30.00			30.00			25.00			30.00		
Grade [%]	0.00			0.00			0.00			0.00		
Crosswalk	Yes			Yes			Yes			Yes		

**Volumes**

Name	Croak Road			Croak Road			Central Parkway			Westbound		
Base Volume Input [veh/h]	56	113	26	0	69	107	185	180	29	14	241	0
Base Volume Adjustment Factor	1.0000	1.0000	1.0000	1.0000	1.0000	1.0000	1.0000	1.0000	1.0000	1.0000	1.0000	1.0000
Heavy Vehicles Percentage [%]	2.00	2.00	2.00	2.00	2.00	2.00	2.00	2.00	2.00	2.00	2.00	2.00
Growth Factor	1.0000	1.0000	1.0000	1.0000	1.0000	1.0000	1.0000	1.0000	1.0000	1.0000	1.0000	1.0000
In-Process Volume [veh/h]	0	0	0	0	0	0	0	0	0	0	0	0
Site-Generated Trips [veh/h]	0	0	0	0	0	0	0	0	0	0	0	0
Diverted Trips [veh/h]	0	0	0	0	0	0	0	0	0	0	0	0
Pass-by Trips [veh/h]	0	0	0	0	0	0	0	0	0	0	0	0
Existing Site Adjustment Volume [veh/h]	0	0	0	0	0	0	0	0	0	0	0	0
Other Volume [veh/h]	0	0	0	0	0	0	0	0	0	0	0	0
Total Hourly Volume [veh/h]	56	113	26	0	69	107	185	180	29	14	241	0
Peak Hour Factor	1.0000	1.0000	1.0000	1.0000	1.0000	1.0000	1.0000	1.0000	1.0000	1.0000	1.0000	1.0000
Other Adjustment Factor	1.0000	1.0000	1.0000	1.0000	1.0000	1.0000	1.0000	1.0000	1.0000	1.0000	1.0000	1.0000
Total 15-Minute Volume [veh/h]	14	28	7	0	17	27	46	45	7	4	60	0
Total Analysis Volume [veh/h]	56	113	26	0	69	107	185	180	29	14	241	0
Pedestrian Volume [ped/h]	0			0			0			0		



**Intersection Settings****Lanes**

Capacity per Entry Lane [veh/h]	587	615	645	622
Degree of Utilization, x	0.33	0.29	0.61	0.41

**Movement, Approach, & Intersection Results**

95th-Percentile Queue Length [veh]	1.45	1.18	4.17	2.00
95th-Percentile Queue Length [ft]	36.24	29.44	104.17	49.91
Approach Delay [s/veh]	12.16	11.18	16.98	12.75
Approach LOS	B	B	C	B
Intersection Delay [s/veh]	14.00			
Intersection LOS	B			

**Intersection Level Of Service Report**  
**Intersection 21: Croak Road & Project Access (Parcel 8)**

Control Type:	Two-way stop	Delay (sec / veh):	10.4
Analysis Method:	HCM 7th Edition	Level Of Service:	B
Analysis Period:	15 minutes	Volume to Capacity (v/c):	0.019

**Intersection Setup**

Name	Croak Road		Croak Road		Project Access (Parcel 8)	
Approach	Northbound		Southbound		Westbound	
Lane Configuration	↩		↪		↔	
Turning Movement	Thru	Right	Left	Thru	Left	Right
Lane Width [ft]	12.00	12.00	12.00	12.00	12.00	12.00
No. of Lanes in Entry Pocket	0	0	0	0	0	0
Entry Pocket Length [ft]	100.00	100.00	100.00	100.00	100.00	100.00
No. of Lanes in Exit Pocket	0	0	0	0	0	0
Exit Pocket Length [ft]	0.00	0.00	0.00	0.00	0.00	0.00
Speed [mph]	30.00		30.00		30.00	
Grade [%]	0.00		0.00		0.00	
Crosswalk	Yes		Yes		Yes	

**Volumes**

Name	Croak Road		Croak Road		Project Access (Parcel 8)	
Base Volume Input [veh/h]	165	30	10	102	13	3
Base Volume Adjustment Factor	1.0000	1.0000	1.0000	1.0000	1.0000	1.0000
Heavy Vehicles Percentage [%]	2.00	2.00	2.00	2.00	2.00	2.00
Growth Factor	1.0000	1.0000	1.0000	1.0000	1.0000	1.0000
In-Process Volume [veh/h]	0	0	0	0	0	0
Site-Generated Trips [veh/h]	0	0	0	0	0	0
Diverted Trips [veh/h]	0	0	0	0	0	0
Pass-by Trips [veh/h]	0	0	0	0	0	0
Existing Site Adjustment Volume [veh/h]	0	0	0	0	0	0
Other Volume [veh/h]	0	0	0	0	0	0
Total Hourly Volume [veh/h]	165	30	10	102	13	3
Peak Hour Factor	1.0000	1.0000	1.0000	1.0000	1.0000	1.0000
Other Adjustment Factor	1.0000	1.0000	1.0000	1.0000	1.0000	1.0000
Total 15-Minute Volume [veh/h]	41	8	3	26	3	1
Total Analysis Volume [veh/h]	165	30	10	102	13	3
Pedestrian Volume [ped/h]	0		0		0	



**Intersection Settings**

Priority Scheme	Free	Free	Stop
Flared Lane			No
Storage Area [veh]	0	0	0
Two-Stage Gap Acceptance			No
Number of Storage Spaces in Median	0	0	0

**Movement, Approach, & Intersection Results**

V/C, Movement V/C Ratio	0.00	0.00	0.01	0.00	0.02	0.00
d_M, Delay for Movement [s/veh]	0.00	0.00	7.62	0.00	10.38	9.29
Movement LOS	A	A	A	A	B	A
95th-Percentile Queue Length [veh/ln]	0.00	0.00	0.02	0.02	0.07	0.07
95th-Percentile Queue Length [ft/ln]	0.00	0.00	0.42	0.42	1.72	1.72
d_A, Approach Delay [s/veh]	0.00		0.68		10.17	
Approach LOS	A		A		B	
d_I, Intersection Delay [s/veh]	0.74					
Intersection LOS	B					



**Intersection Level Of Service Report**  
**Intersection 22: Croak Road & Dublin Boulevard**

Control Type:	Signalized	Delay (sec / veh):	44.6
Analysis Method:	HCM 7th Edition	Level Of Service:	D
Analysis Period:	15 minutes	Volume to Capacity (v/c):	0.848

**Intersection Setup**

Name	Croak Road			Croak Road			Dublin Boulevard			Dublin Boulevard		
Approach	Northbound			Southbound			Eastbound			Westbound		
Lane Configuration												
Turning Movement	Left	Thru	Right	Left	Thru	Right	Left	Thru	Right	Left	Thru	Right
Lane Width [ft]	12.00	12.00	12.00	12.00	12.00	12.00	12.00	12.00	12.00	12.00	12.00	12.00
No. of Lanes in Entry Pocket	1	0	0	1	0	1	1	0	1	1	0	1
Entry Pocket Length [ft]	100.00	100.00	100.00	100.00	100.00	100.00	210.00	100.00	250.00	150.00	100.00	250.00
No. of Lanes in Exit Pocket	0	0	0	0	0	0	0	0	0	0	0	0
Exit Pocket Length [ft]	0.00	0.00	0.00	0.00	0.00	0.00	0.00	0.00	0.00	0.00	0.00	0.00
Speed [mph]	30.00			30.00			30.00			30.00		
Grade [%]	0.00			0.00			0.00			0.00		
Curb Present	No			No			No			No		
Crosswalk	Yes			Yes			Yes			Yes		



**Volumes**

Name	Croak Road			Croak Road			Dublin Boulevard			Dublin Boulevard		
Base Volume Input [veh/h]	176	13	147	47	9	164	107	1905	55	84	265	65
Base Volume Adjustment Factor	1.0000	1.0000	1.0000	1.0000	1.0000	1.0000	1.0000	1.0000	1.0000	1.0000	1.0000	1.0000
Heavy Vehicles Percentage [%]	2.00	2.00	2.00	2.00	2.00	2.00	2.00	2.00	2.00	2.00	2.00	2.00
Proportion of CAVs [%]	0.00											
Growth Factor	1.0000	1.0000	1.0000	1.0000	1.0000	1.0000	1.0000	1.0000	1.0000	1.0000	1.0000	1.0000
In-Process Volume [veh/h]	0	0	0	0	0	0	0	0	0	0	0	0
Site-Generated Trips [veh/h]	0	0	0	0	0	0	0	0	0	0	0	0
Diverted Trips [veh/h]	0	0	0	0	0	0	0	0	0	0	0	0
Pass-by Trips [veh/h]	0	0	0	0	0	0	0	0	0	0	0	0
Existing Site Adjustment Volume [veh/h]	0	0	0	0	0	0	0	0	0	0	0	0
Other Volume [veh/h]	0	0	0	0	0	0	0	0	0	0	0	0
Right Turn on Red Volume [veh/h]	0	0	0	0	0	0	0	0	0	0	0	0
Total Hourly Volume [veh/h]	176	13	147	47	9	164	107	1905	55	84	265	65
Peak Hour Factor	1.0000	1.0000	1.0000	1.0000	1.0000	1.0000	1.0000	1.0000	1.0000	1.0000	1.0000	1.0000
Other Adjustment Factor	1.0000	1.0000	1.0000	1.0000	1.0000	1.0000	1.0000	1.0000	1.0000	1.0000	1.0000	1.0000
Total 15-Minute Volume [veh/h]	44	3	37	12	2	41	27	476	14	21	66	16
Total Analysis Volume [veh/h]	176	13	147	47	9	164	107	1905	55	84	265	65
Presence of On-Street Parking	No		No	No		No	No		No	No		No
On-Street Parking Maneuver Rate [/h]	0	0	0	0	0	0	0	0	0	0	0	0
Local Bus Stopping Rate [/h]	0	0	0	0	0	0	0	0	0	0	0	0
v_do, Outbound Pedestrian Volume crossing	0			0			0			0		
v_di, Inbound Pedestrian Volume crossing m	0			0			0			0		
v_co, Outbound Pedestrian Volume crossing	0			0			0			0		
v_ci, Inbound Pedestrian Volume crossing mi	0			0			0			0		
v_ab, Corner Pedestrian Volume [ped/h]	0			0			0			0		
Bicycle Volume [bicycles/h]	0			0			0			0		



**Intersection Settings**

Located in CBD	No
Signal Coordination Group	-
Cycle Length [s]	160
Active Pattern	Pattern 1
Coordination Type	Time of Day Pattern Isolated
Actuation Type	Fully actuated
Offset [s]	0.0
Offset Reference	Lead Green - Beginning of First Green
Permissive Mode	SingleBand
Lost time [s]	12.00

**Phasing & Timing (Basic)**

Control Type	Protecte	Permiss	Permiss	Protecte	Permiss	Permiss	Protecte	Permiss	Permiss	Protecte	Permiss	Permiss
Signal Group	1	6	0	5	2	0	3	8	0	7	4	0
Auxiliary Signal Groups												
Maximum Green [s]	5	26	0	5	26	0	5	126	0	5	126	0
Amber [s]	3.0	3.0	0.0	3.0	3.0	0.0	3.0	3.0	0.0	3.0	3.0	0.0
All red [s]	1.0	1.0	0.0	1.0	1.0	0.0	1.0	1.0	0.0	1.0	1.0	0.0
Walk [s]	0	5	0	0	5	0	0	5	0	0	5	0
Pedestrian Clearance [s]	0	21	0	0	21	0	0	10	0	0	10	0
Delayed Vehicle Green [s]	0.0	0.0	0.0	0.0	0.0	0.0	0.0	0.0	0.0	0.0	0.0	0.0
Rest In Walk		No			No			No			No	
I1, Start-Up Lost Time [s]	2.0	2.0	0.0	2.0	2.0	0.0	2.0	2.0	0.0	2.0	2.0	0.0
I2, Clearance Lost Time [s]	2.0	2.0	0.0	2.0	2.0	0.0	2.0	2.0	0.0	2.0	2.0	0.0
Detector Location [ft]	0.0	0.0	0.0	0.0	0.0	0.0	0.0	0.0	0.0	0.0	0.0	0.0
Detector Length [ft]	20.0	20.0	0.0	0.0	0.0	0.0	20.0	20.0	0.0	20.0	20.0	0.0
I, Upstream Filtering Factor	1.00	1.00	1.00	1.00	1.00	1.00	1.00	1.00	1.00	1.00	1.00	1.00

**Phasing & Timing: Pattern 1**

Split [s]	21	30	0	21	30	0	64	96	0	13	45	0
Lead / Lag	Lead	-	-	Lead	-	-	Lead	-	-	Lead	-	-
Minimum Green [s]	5	10	0	5	10	0	5	10	0	5	10	0
Vehicle Extension [s]	3.0	3.0	0.0	3.0	3.0	0.0	3.0	3.0	0.0	3.0	3.0	0.0
Minimum Recall	No	No		No	No		No	No		No	No	
Maximum Recall	No	No		No	No		No	No		No	No	
Pedestrian Recall	No	No		No	No		No	No		No	No	

**Exclusive Pedestrian Phase**

Pedestrian Signal Group	0
Pedestrian Walk [s]	0
Pedestrian Clearance [s]	0



**Lane Group Calculations**

Lane Group	L	C	L	C	R	L	C	R	L	C	R
C, Cycle Length [s]	160	160	160	160	160	160	160	160	160	160	160
L, Total Lost Time per Cycle [s]	4.00	4.00	4.00	4.00	4.00	4.00	4.00	4.00	4.00	4.00	4.00
l1_p, Permitted Start-Up Lost Time [s]	0.00	0.00	0.00	0.00	0.00	0.00	0.00	0.00	0.00	0.00	0.00
l2, Clearance Lost Time [s]	2.00	2.00	2.00	2.00	2.00	2.00	2.00	2.00	2.00	2.00	2.00
g_i, Effective Green Time [s]	17	38	5	27	27	12	91	91	9	89	89
g / C, Green / Cycle	0.11	0.24	0.03	0.17	0.17	0.07	0.57	0.57	0.06	0.55	0.55
(v / s)_i Volume / Saturation Flow Rate	0.10	0.10	0.03	0.00	0.10	0.06	0.54	0.03	0.05	0.07	0.04
s, saturation flow rate [veh/h]	1781	1609	1781	1870	1589	1781	3560	1589	1781	3560	1589
c, Capacity [veh/h]	188	384	61	312	266	130	2034	908	100	1974	881
d1, Uniform Delay [s]	71.04	51.53	76.67	55.78	61.90	73.18	31.64	15.24	74.81	17.15	16.55
k, delay calibration	0.37	0.50	0.11	0.50	0.50	0.11	0.11	0.11	0.25	0.11	0.11
l, Upstream Filtering Factor	1.00	1.00	1.00	1.00	1.00	1.00	1.00	1.00	1.00	1.00	1.00
d2, Incremental Delay [s]	42.11	3.31	18.43	0.17	10.32	12.21	2.59	0.03	32.85	0.03	0.04
d3, Initial Queue Delay [s]	0.00	0.00	0.00	0.00	0.00	0.00	0.00	0.00	0.00	0.00	0.00
Rp, platoon ratio	1.00	1.00	1.00	1.00	1.00	1.00	1.00	1.00	1.00	1.00	1.00
PF, progression factor	1.00	1.00	1.00	1.00	1.00	1.00	1.00	1.00	1.00	1.00	1.00

**Lane Group Results**

X, volume / capacity	0.94	0.42	0.77	0.03	0.62	0.82	0.94	0.06	0.84	0.13	0.07
d, Delay for Lane Group [s/veh]	113.15	54.84	95.10	55.95	72.22	85.39	34.23	15.27	107.66	17.18	16.59
Lane Group LOS	F	D	F	E	E	F	C	B	F	B	B
Critical Lane Group	Yes	No	No	No	Yes	No	Yes	No	Yes	No	No
50th-Percentile Queue Length [veh/ln]	9.40	5.85	2.24	0.32	7.01	4.80	33.89	0.93	4.36	2.43	1.16
50th-Percentile Queue Length [ft/ln]	234.92	146.33	56.12	8.09	175.15	120.07	847.14	23.22	108.93	60.79	28.89
95th-Percentile Queue Length [veh/ln]	14.42	9.82	4.04	0.58	11.35	8.40	43.43	1.67	7.78	4.38	2.08
95th-Percentile Queue Length [ft/ln]	360.60	245.53	101.01	14.56	283.67	209.92	1085.81	41.80	194.51	109.42	52.01





**Movement, Approach, & Intersection Results**

d_M, Delay for Movement [s/veh]	113.15	54.84	54.84	95.10	55.95	72.22	85.39	34.23	15.27	107.66	17.18	16.59
Movement LOS	F	D	D	F	E	E	F	C	B	F	B	B
d_A, Approach Delay [s/veh]	85.38			76.44			36.37			35.45		
Approach LOS	F			E			D			D		
d_I, Intersection Delay [s/veh]	44.57											
Intersection LOS	D											
Intersection V/C	0.848											

**Emissions**

Vehicle Miles Traveled [mph]	15.05	13.68	11.07	2.12	38.64	32.98	587.20	16.95	6.67	21.05	5.16
Stops [stops/h]	211.40	131.68	50.50	7.28	157.62	108.05	1524.69	20.90	98.03	109.41	26.00
Fuel consumption [US gal/h]	5.84	3.08	1.64	0.23	4.87	3.81	45.87	0.98	2.66	2.40	0.58
CO [g/h]	408.18	215.03	114.94	16.07	340.50	266.58	3206.07	68.80	185.68	167.61	40.24
NOx [g/h]	79.42	41.84	22.36	3.13	66.25	51.87	623.78	13.39	36.13	32.61	7.83
VOC [g/h]	94.60	49.84	26.64	3.73	78.91	61.78	743.04	15.94	43.03	38.84	9.33

**Other Modes**

g_Walk,mi, Effective Walk Time [s]	9.0	9.0	9.0	9.0
M_corner, Corner Circulation Area [ft <sup>2</sup> /ped]	0.00	0.00	0.00	0.00
M_CW, Crosswalk Circulation Area [ft <sup>2</sup> /ped]	0.00	0.00	0.00	0.00
d_p, Pedestrian Delay [s]	71.26	71.26	71.26	71.26
I_p,int, Pedestrian LOS Score for Intersectio	2.126	2.258	2.915	2.890
Crosswalk LOS	B	B	C	C
s_b, Saturation Flow Rate of the bicycle lane	2000	2000	2000	2000
c_b, Capacity of the bicycle lane [bicycles/h]	325	325	1150	512
d_b, Bicycle Delay [s]	56.12	56.12	14.46	44.26
I_b,int, Bicycle LOS Score for Intersection	2.114	1.923	3.265	1.901
Bicycle LOS	B	A	C	A

**Sequence**

Ring 1	1	2	3	4	-	-	-	-	-	-	-	-	-	-	-
Ring 2	5	6	7	8	-	-	-	-	-	-	-	-	-	-	-
Ring 3	-	-	-	-	-	-	-	-	-	-	-	-	-	-	-
Ring 4	-	-	-	-	-	-	-	-	-	-	-	-	-	-	-

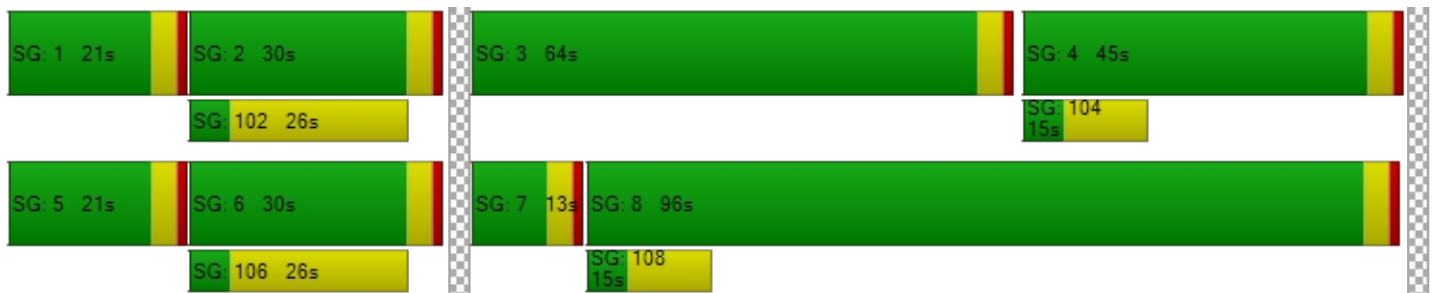



## Appendix L: Near Term Project Only Volumes

Traffic Volume - Net New Site Trips



Hacienda Drive & Dublin Boul Tassajara Road & Central Pa Tassajara Road & Dublin Bou Tassajara Road & I-580 WB

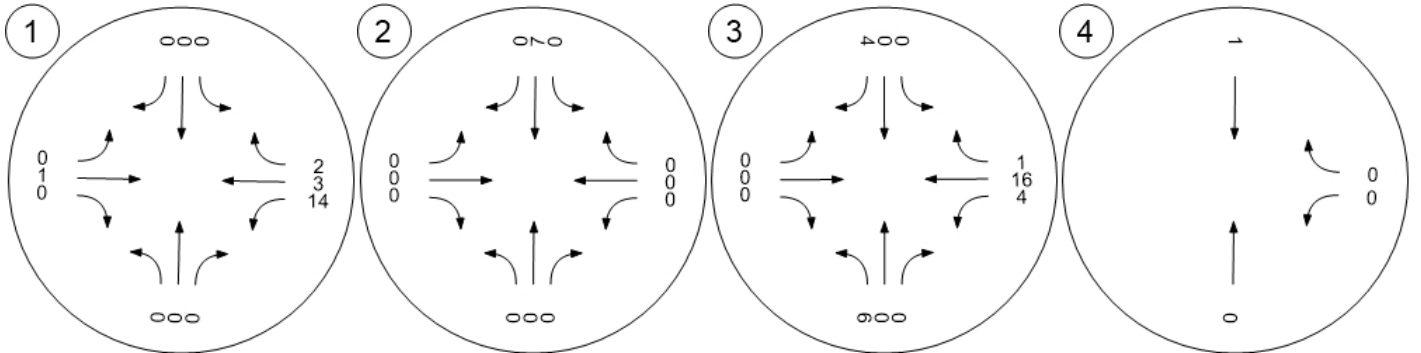

Santa Rita Rd & I-580 EB Ra Tassajara Road & Fallon Roa Fallon Road & Positano Park Fallon Road & Central Parkw

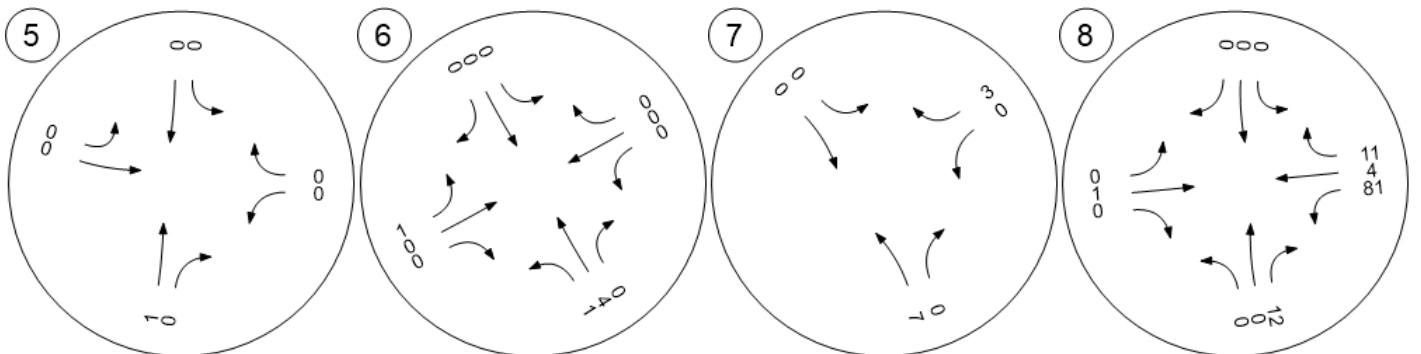

Traffic Volume - Net New Site Trips

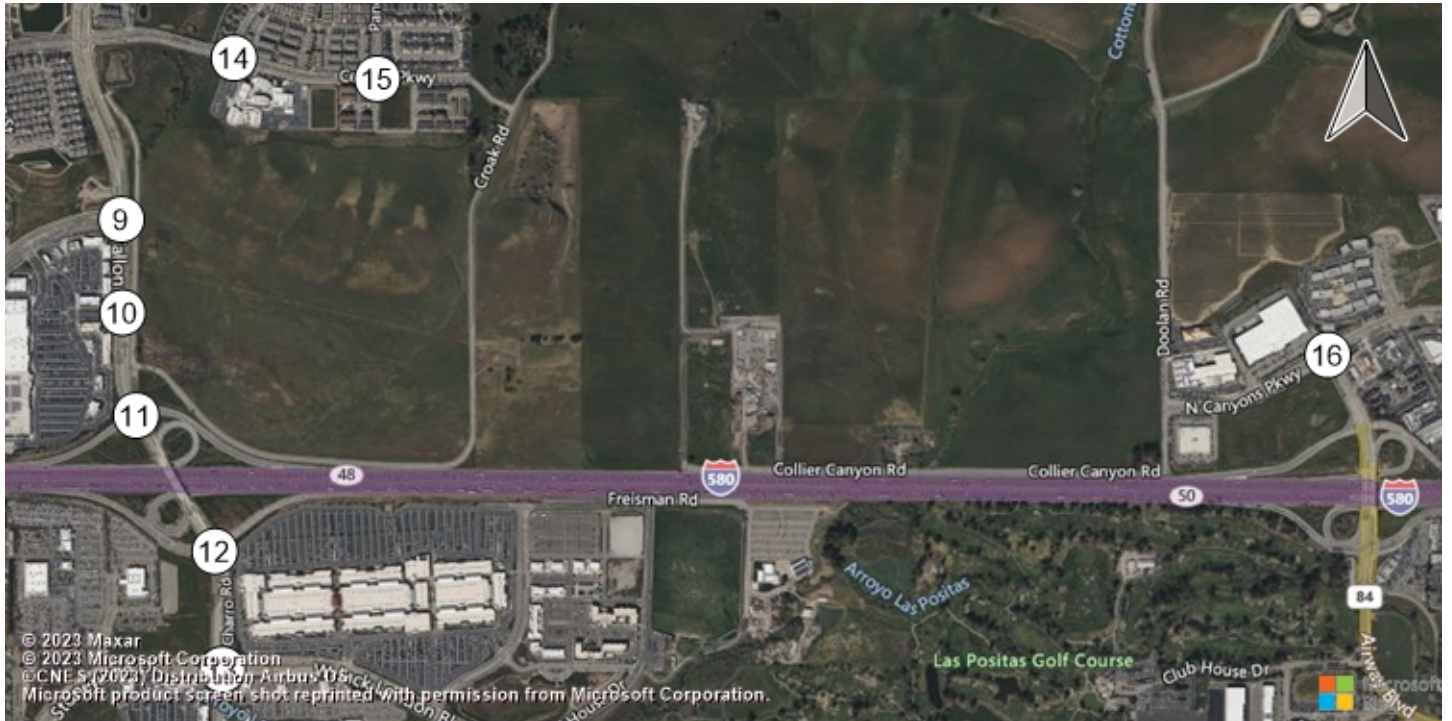

Fallon Road & Dublin Boulevard Fallon Road & Fallon Gateway Fallon Road & I-580 WB Ramp El Charro Road & I-580 EB R

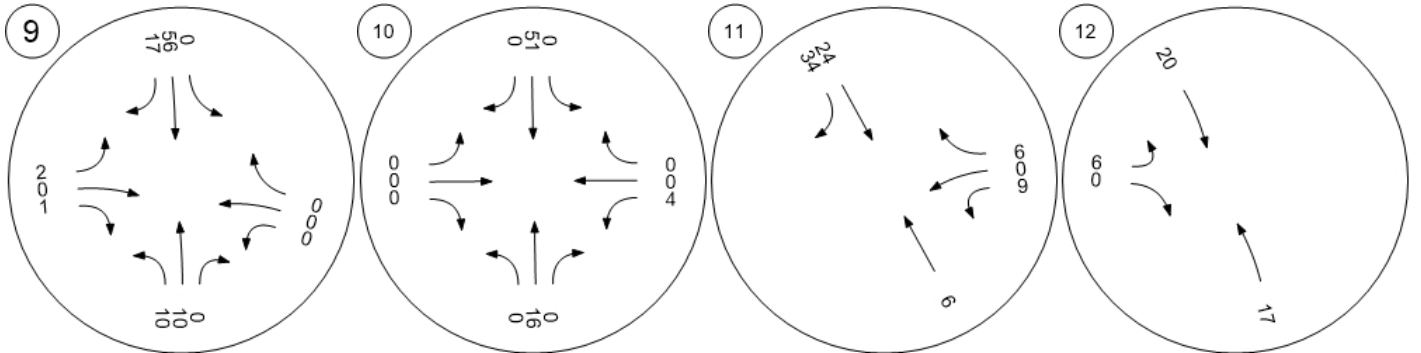

El Charro Road & Jack Lond Central Parkway & Sunset ViCentral Parkway & Panorama Airway Boulevard & N. Canyo

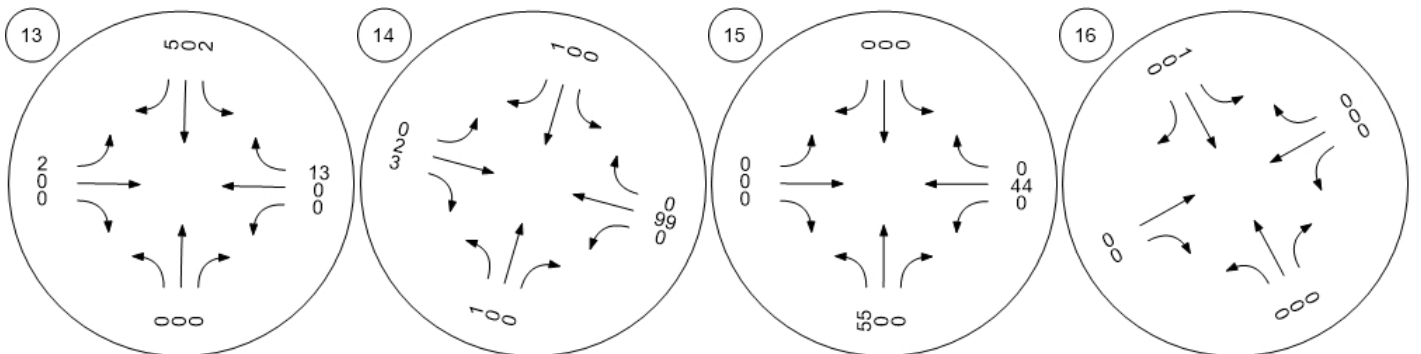



Traffic Volume - Net New Site Trips

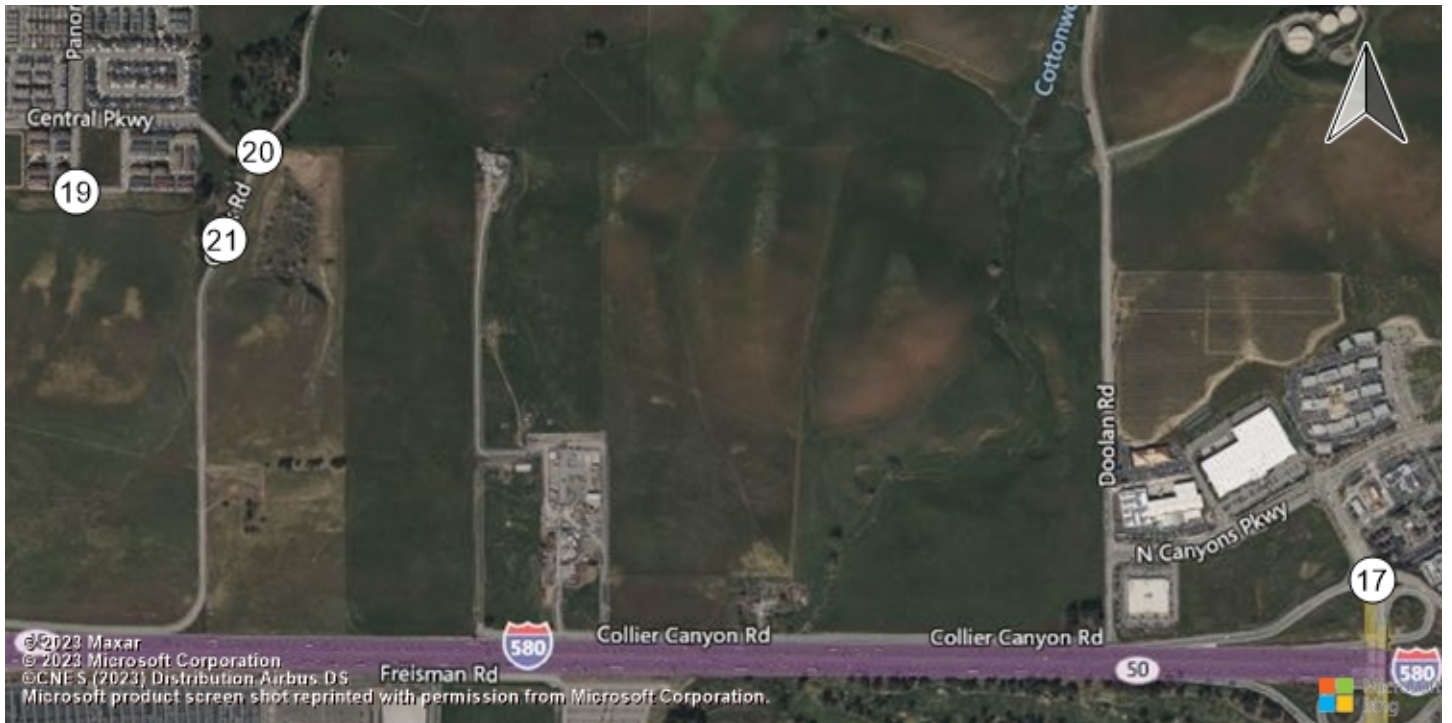

Airway Boulevard & I-580 WB Pandora Way & Residential P Croak Road & Central Parkw Croak Road & Project Access

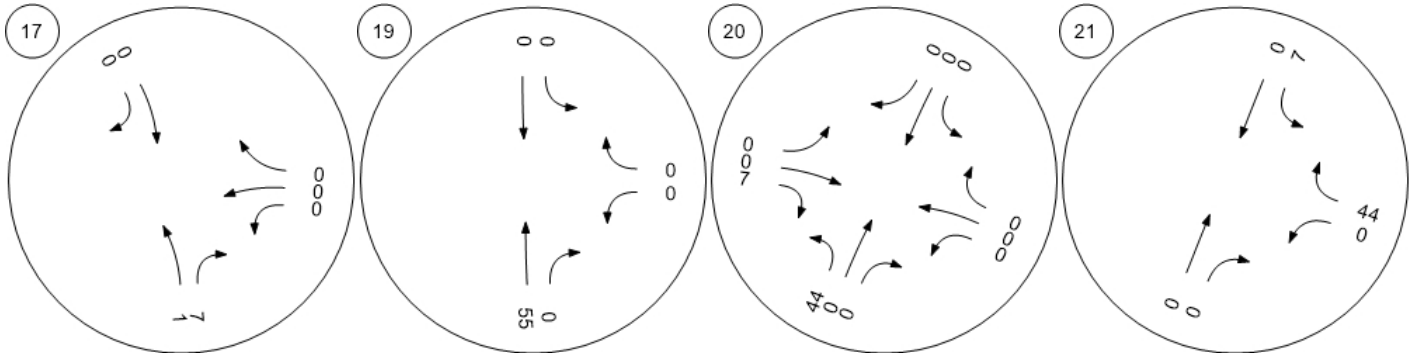

Traffic Volume - Net New Site Trips



Hacienda Drive & Dublin Boul Tassajara Road & Central Pa Tassajara Road & Dublin Bou Tassajara Road & I-580 WB

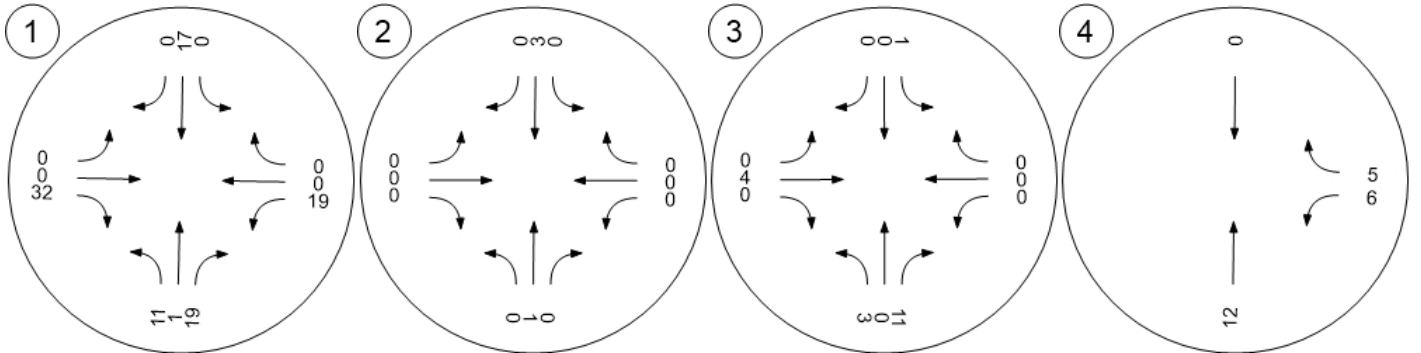

Santa Rita Rd & I-580 EB Ra Tassajara Road & Fallon Roa Fallon Road & Positano Park Fallon Road & Central Parkw

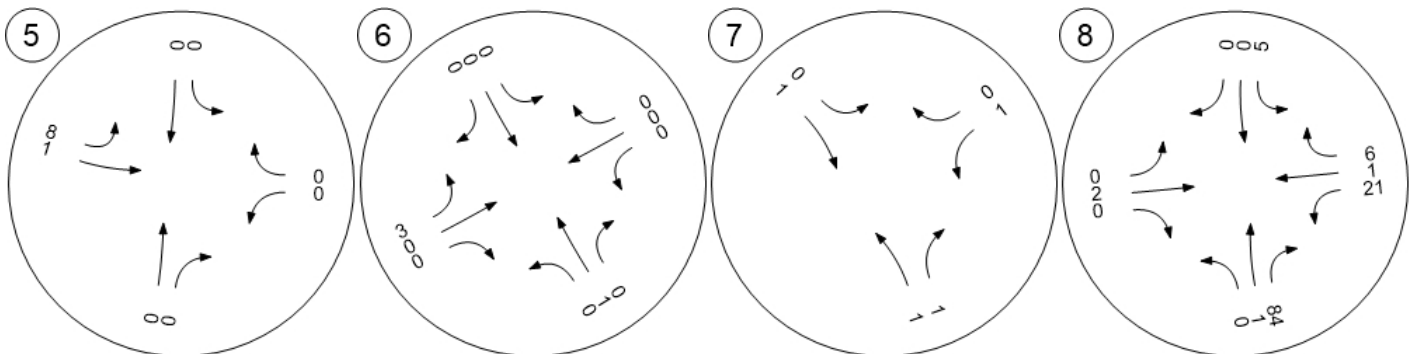

Traffic Volume - Net New Site Trips

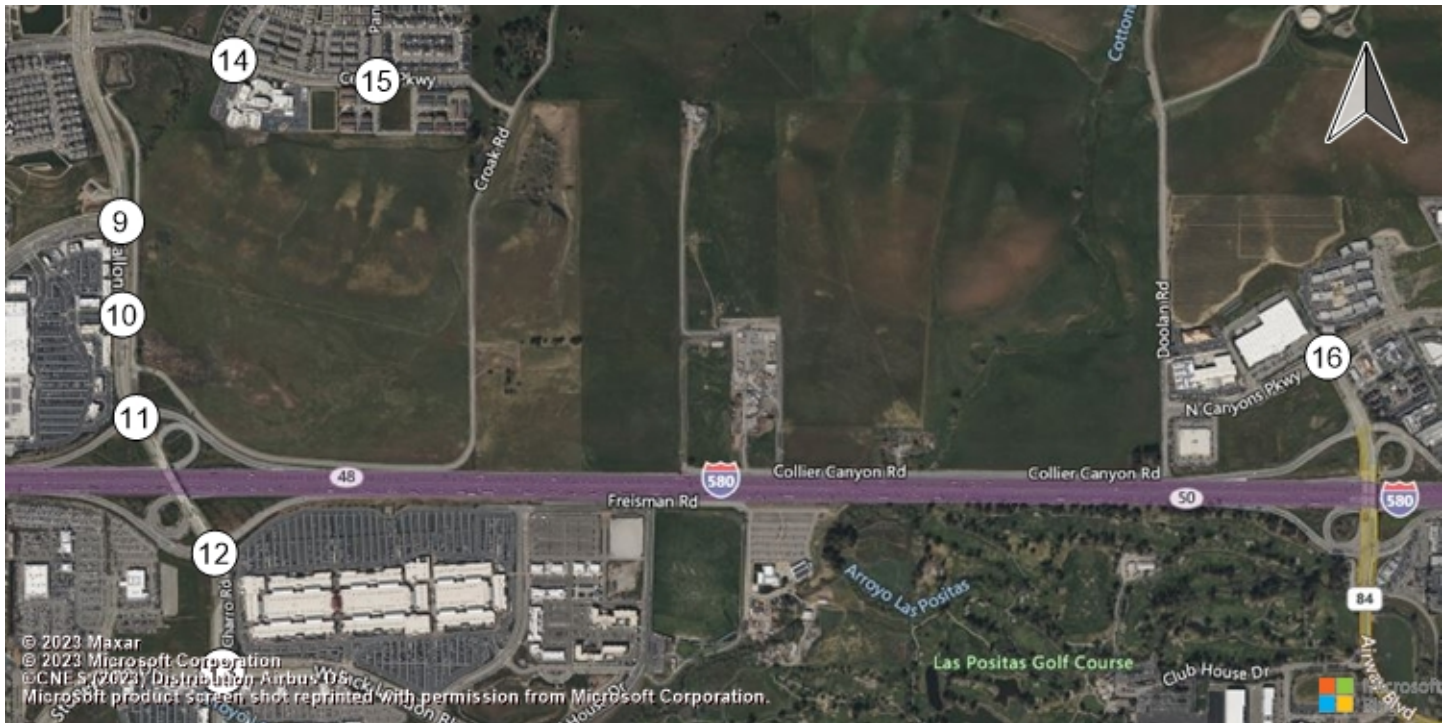

Fallon Road & Dublin Boulevard Fallon Road & Fallon Gateway Fallon Road & I-580 WB Ram El Charro Road & I-580 EB R

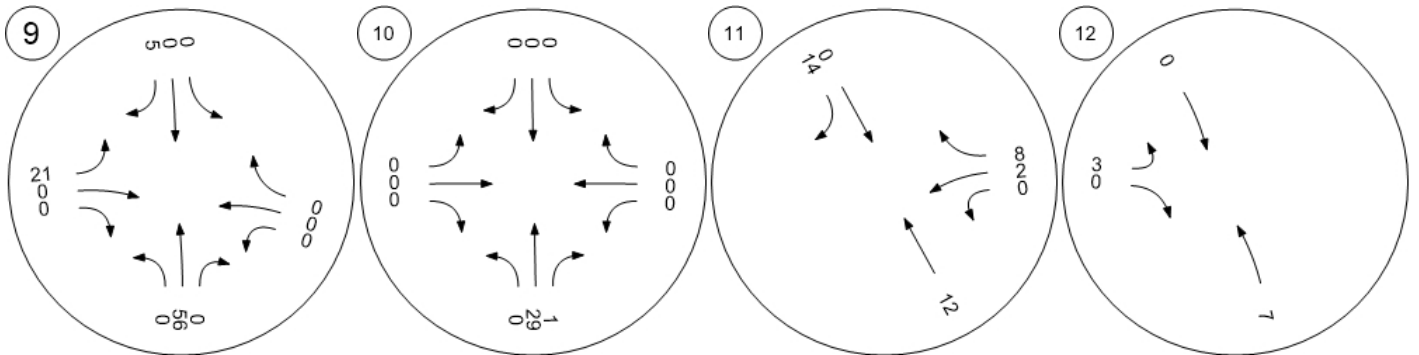

El Charro Road & Jack Lond Central Parkway & Sunset Vi Central Parkway & Panorama Airway Boulevard & N. Canyon

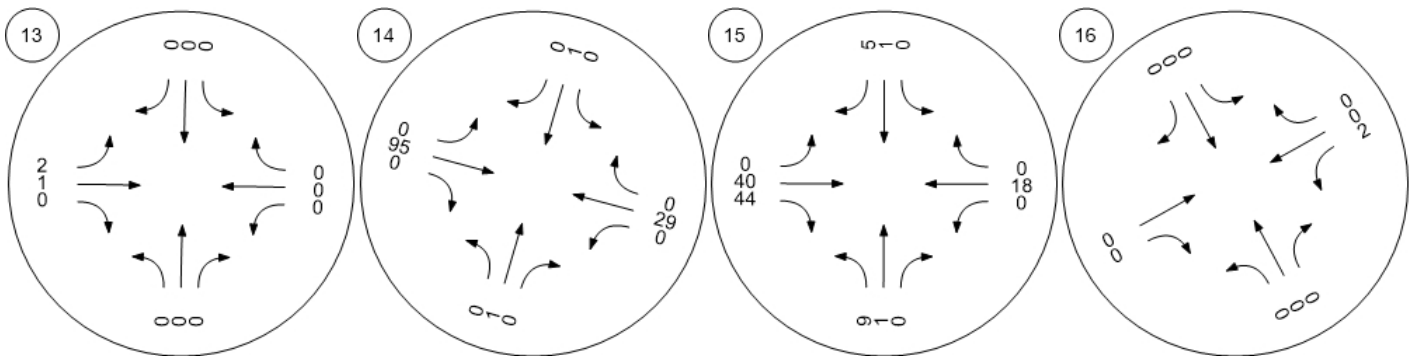



Traffic Volume - Net New Site Trips

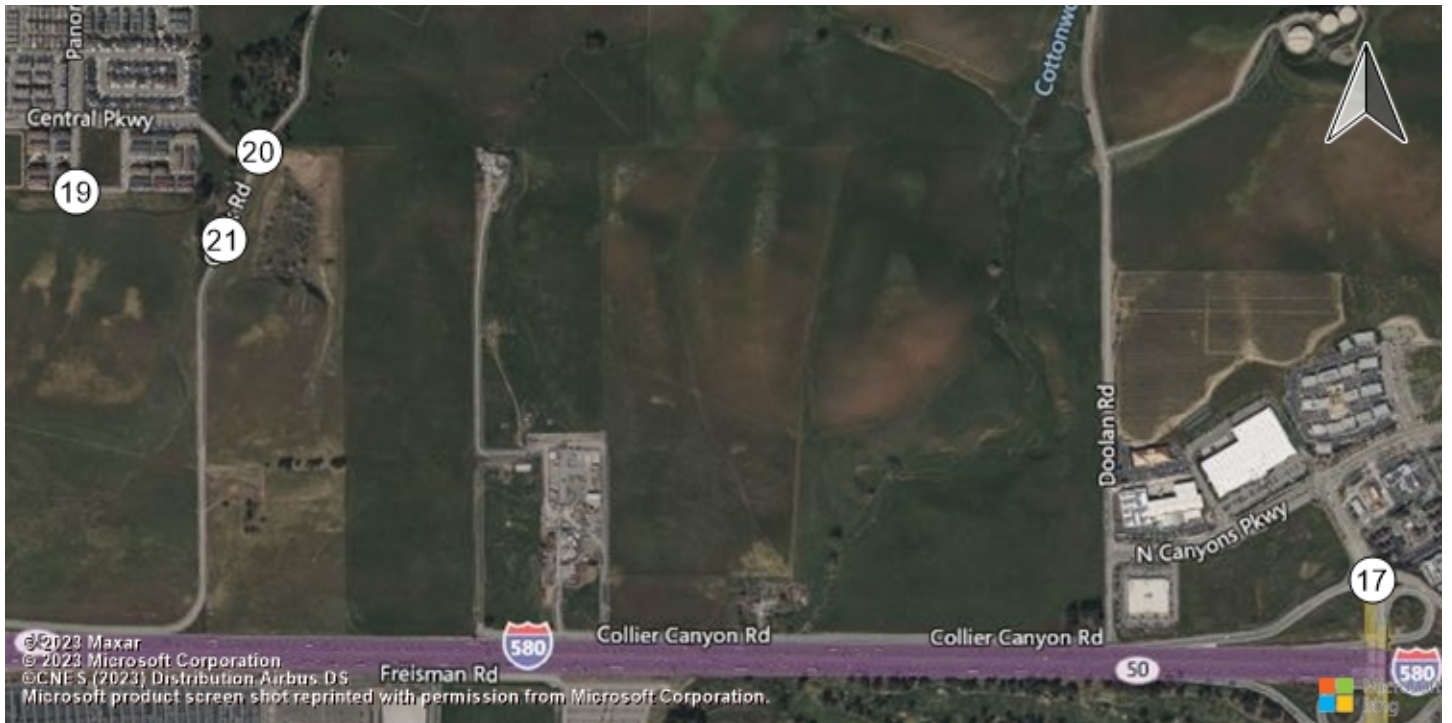

Airway Boulevard & I-580 WB Pandora Way & Residential P Croak Road & Central Parkw Croak Road & Project Access

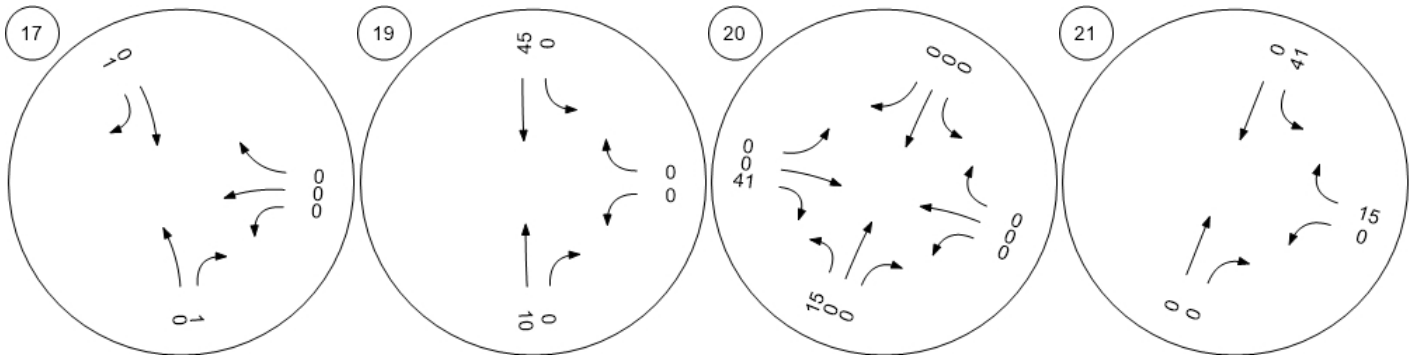





## Appendix M: Cumulative Project Only Volumes

Traffic Volume - Net New Site Trips



Hacienda Drive & Dublin Boul Tassajara Road & Central Pa Tassajara Road & Dublin Bou Tassajara Road & I-580 WB

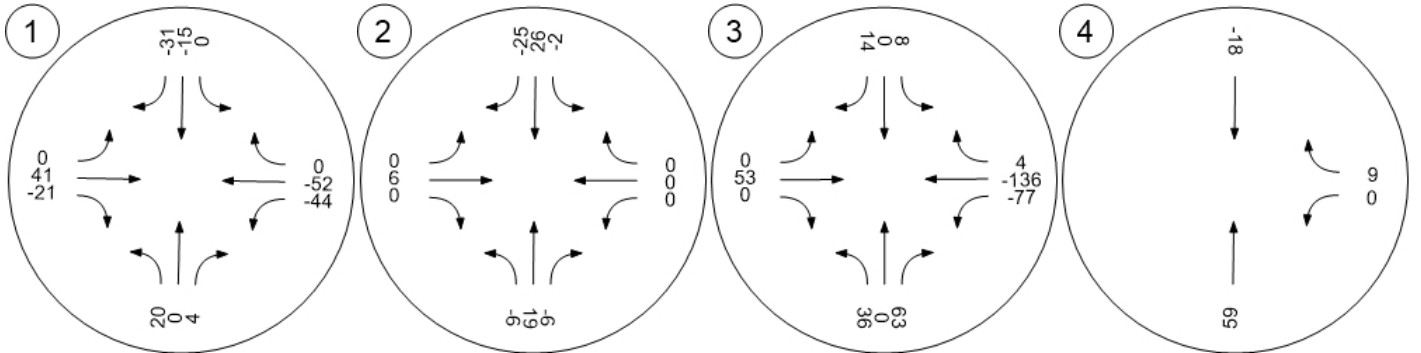

Santa Rita Rd & I-580 EB Ra Tassajara Road & Fallon Roa Fallon Road & Positano Park Fallon Road & Central Parkw

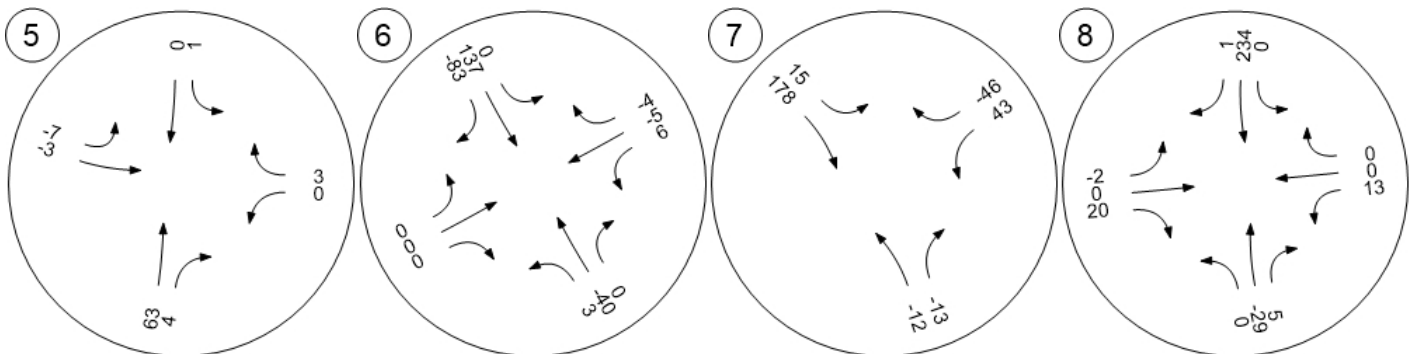

Traffic Volume - Net New Site Trips

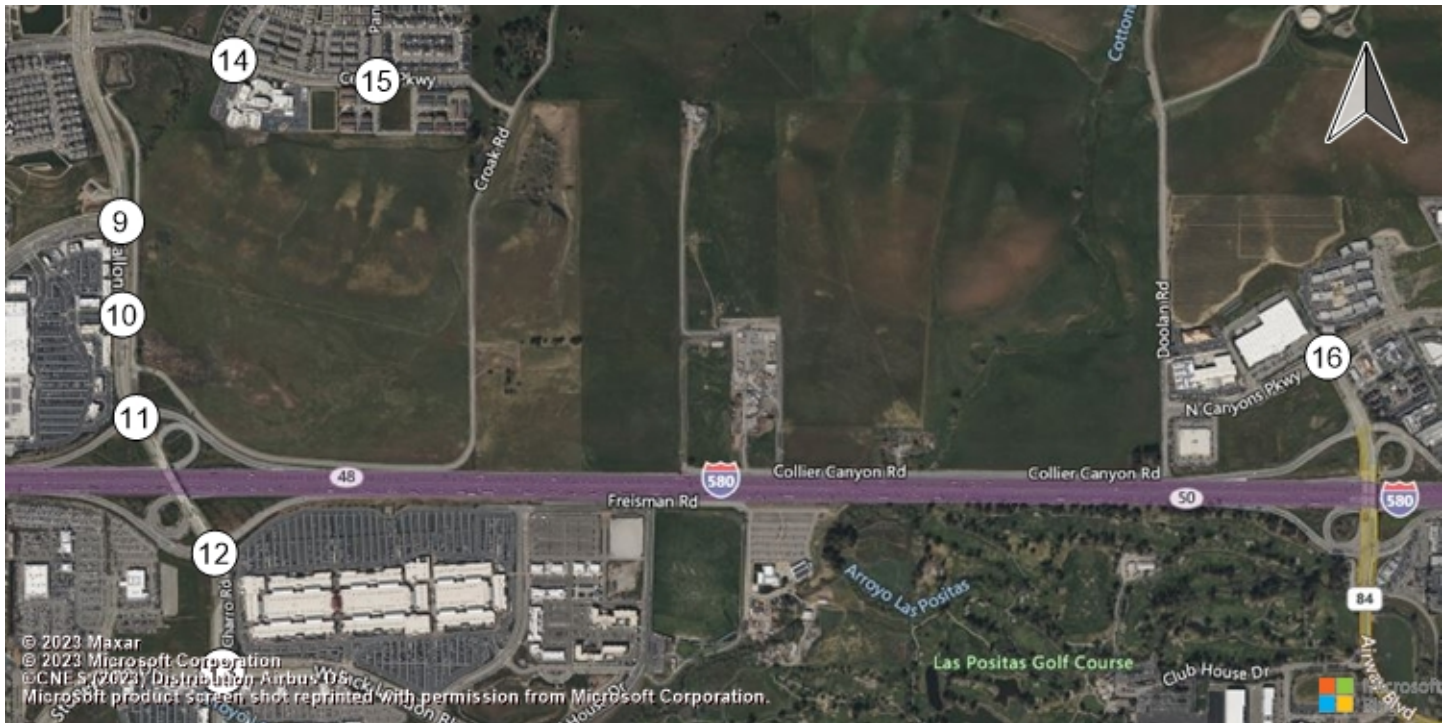

Fallon Road & Dublin Boulevard Fallon Road & Fallon Gateway Fallon Road & I-580 WB Ram El Charro Road & I-580 EB R

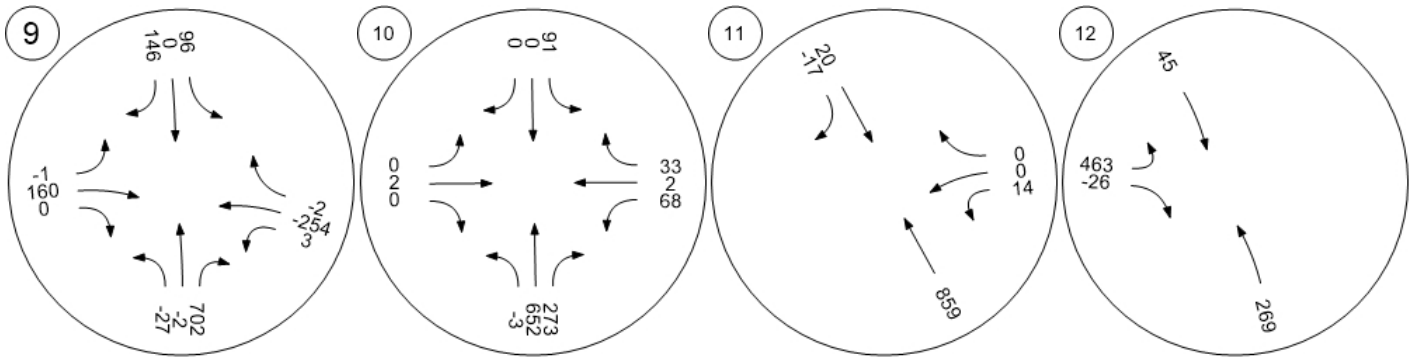

El Charro Road & Jack Lond Central Parkway & Sunset Vi Central Parkway & Panorama Airway Boulevard & N. Canyo

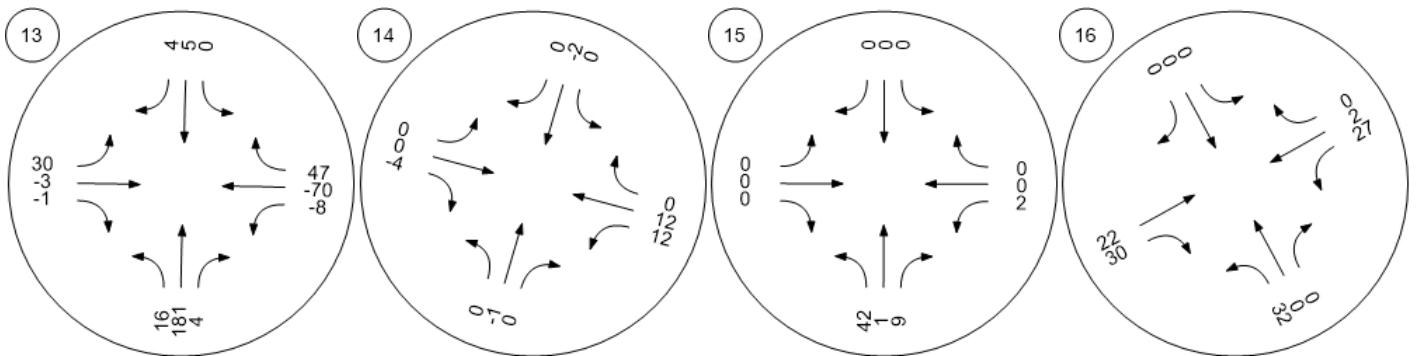



Traffic Volume - Net New Site Trips

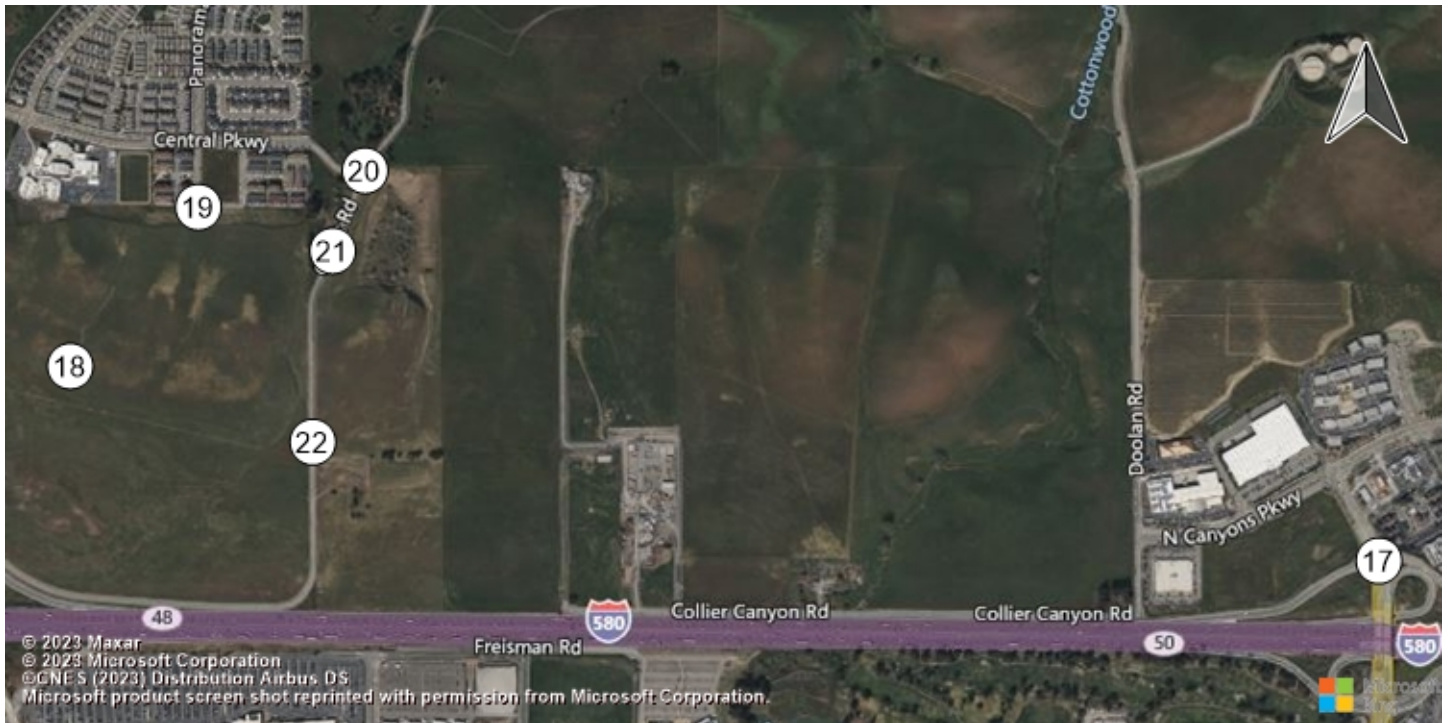

Airway Boulevard & I-580 WB Dublin Boulevard & Commercial Pandora Way & Residential P Croak Road & Central Parkw

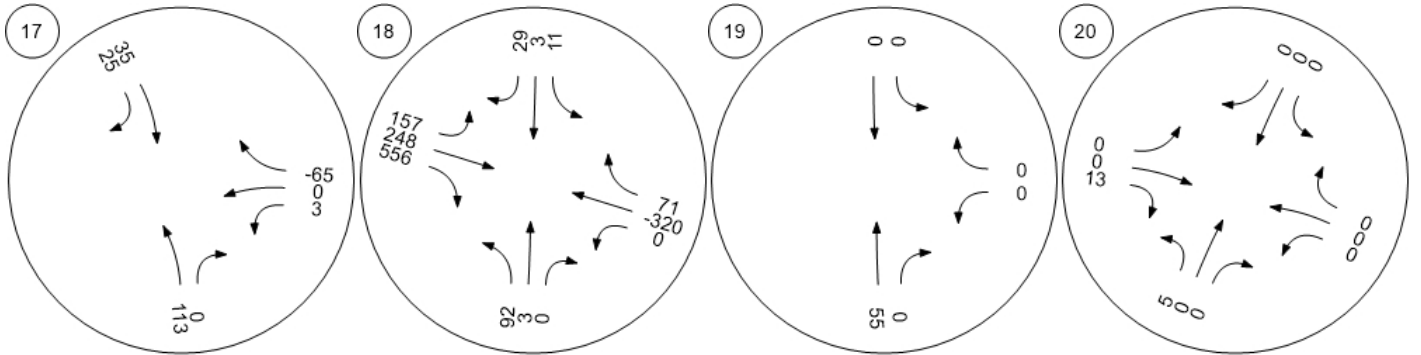

Croak Road & Project Access Croak Road & Dublin Boulev

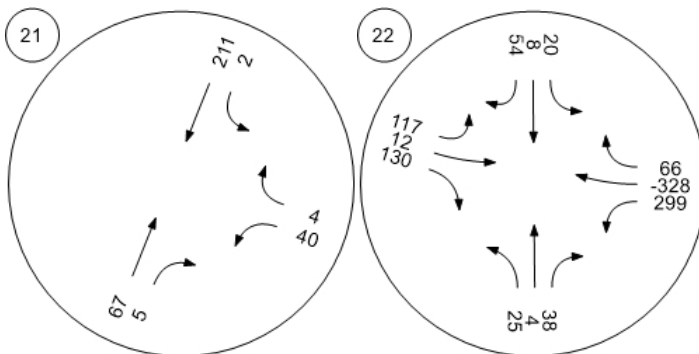

Traffic Volume - Net New Site Trips



Hacienda Drive & Dublin Boul Tassajara Road & Central Pa Tassajara Road & Dublin Bou Tassajara Road & I-580 WB

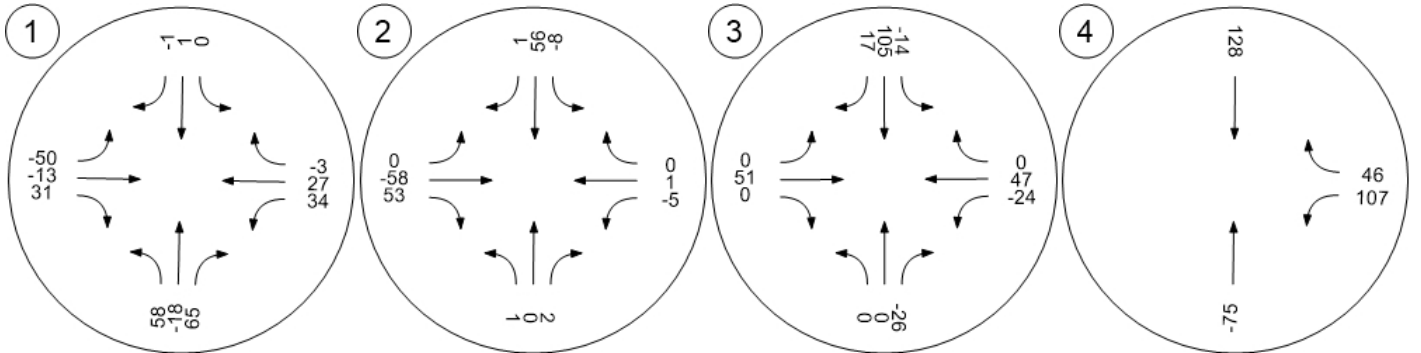

Santa Rita Rd & I-580 EB Ra Tassajara Road & Fallon Roa Fallon Road & Positano Park Fallon Road & Central Parkw

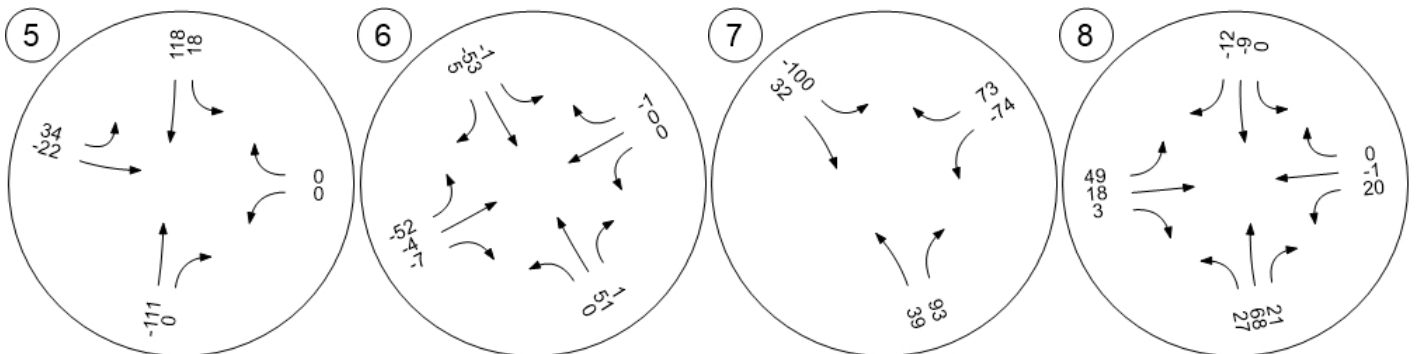



Traffic Volume - Net New Site Trips

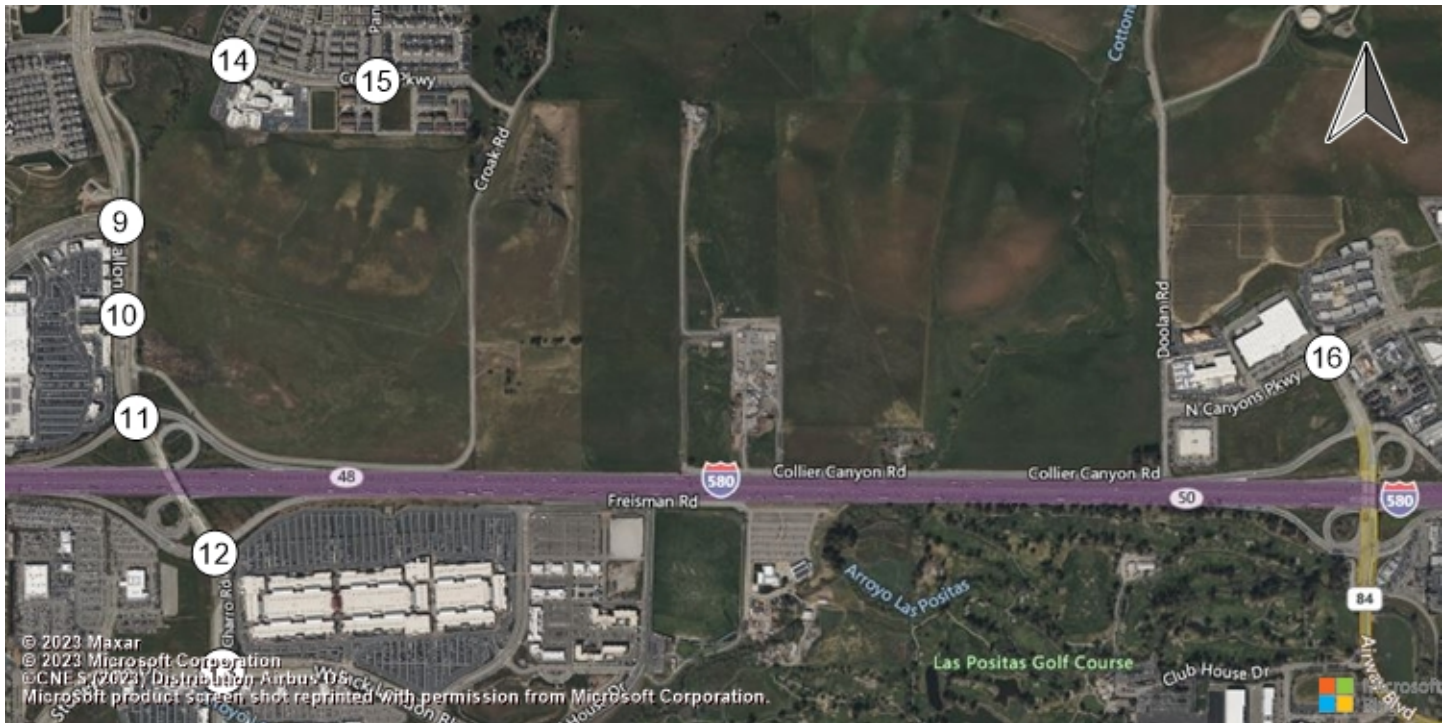

Fallon Road & Dublin Boulevard Fallon Road & Fallon Gateway Fallon Road & I-580 WB Ram El Charro Road & I-580 EB R

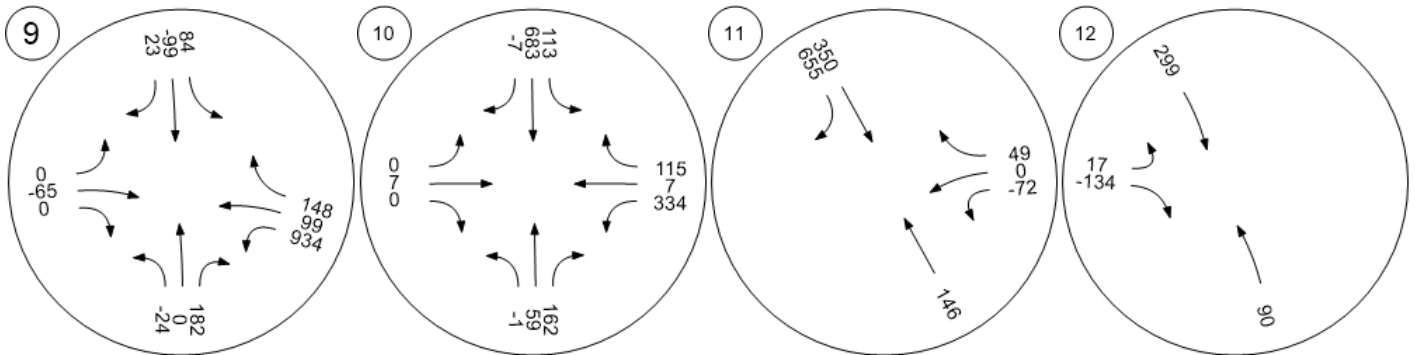

El Charro Road & Jack Lond Central Parkway & Sunset Vi Central Parkway & Panorama Airway Boulevard & N. Canyon

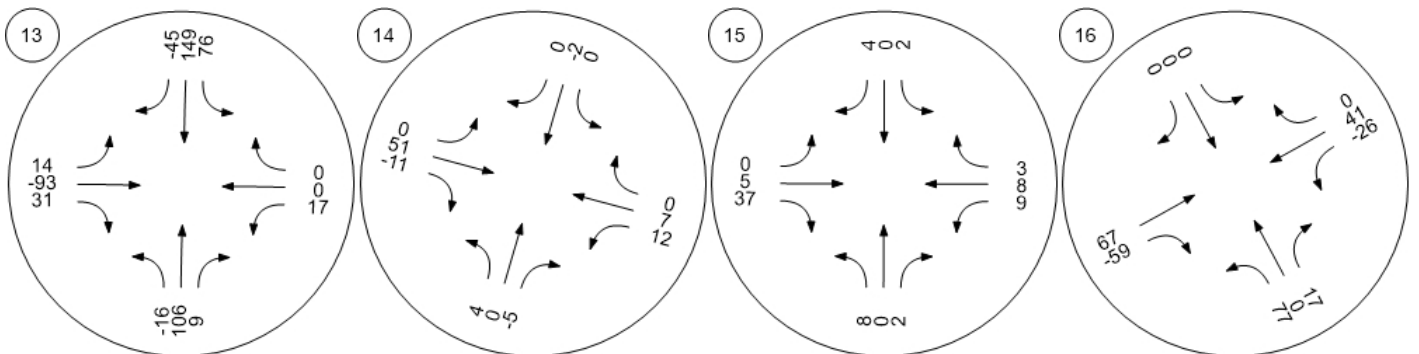

Traffic Volume - Net New Site Trips

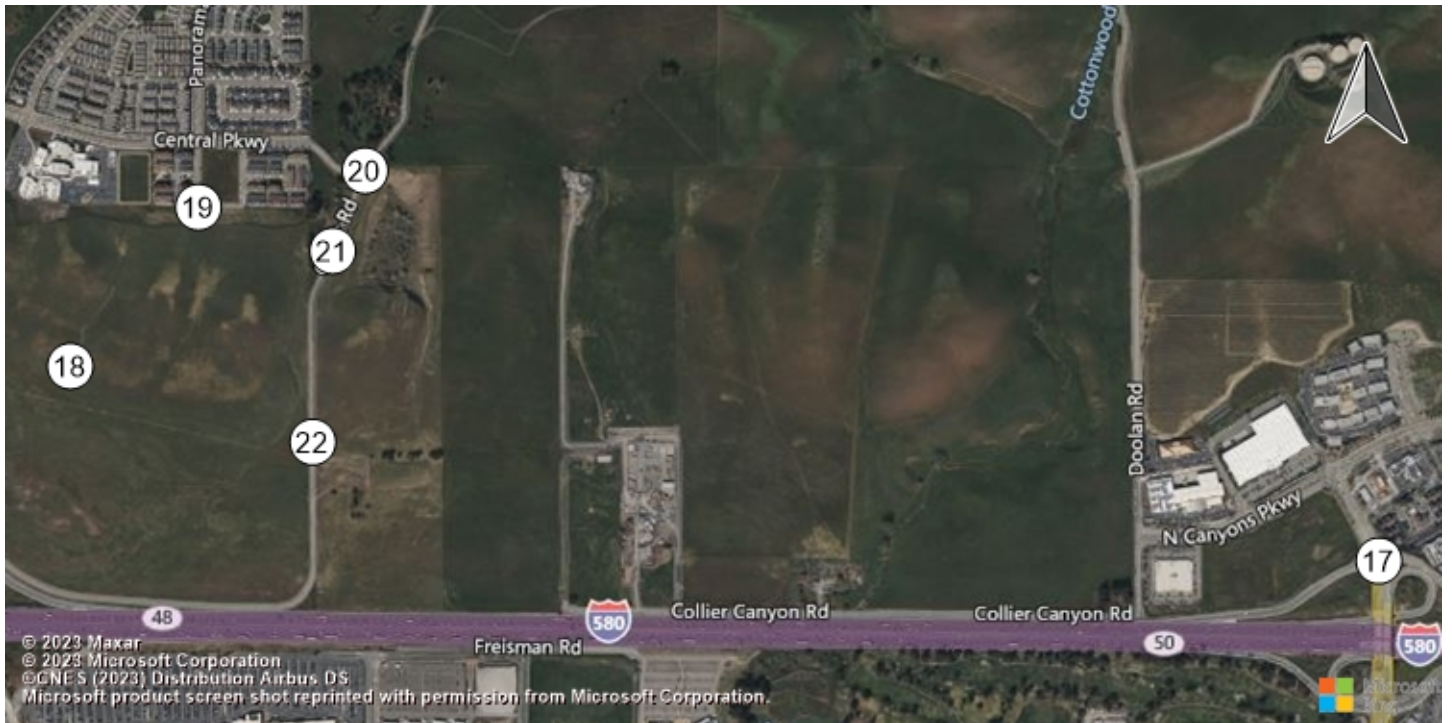

Airway Boulevard & I-580 WB Dublin Boulevard & Commercial Pandora Way & Residential P Croak Road & Central Parkw

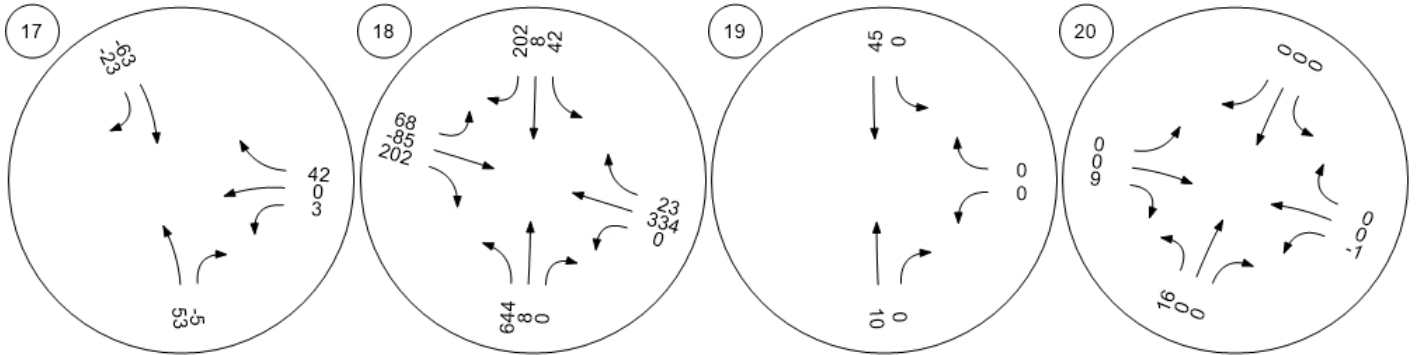

Croak Road & Project Access Croak Road & Dublin Boulev

